

## 110 $\mu$ A Selectable Gain Amplifier

### Features

- 3 Gain Selections:
  - +1, +10, +50 V/V
- One Gain Select Input per Amplifier
- Rail-to-Rail Input and Output
- Low Gain Error:  $\pm 1\%$  (max.)
- High Bandwidth: 250 kHz to 900 kHz (typ.)
- Low Supply Current: 110  $\mu$ A (typ.)
- Single Supply: 1.8V to 5.5V
- Extended Temperature Range:  $-40^{\circ}\text{C}$  to  $+125^{\circ}\text{C}$

### Typical Applications

- A/D Converter Driver
- Industrial Instrumentation
- Bar Code Readers
- Metering
- Digital Cameras

### Block Diagram

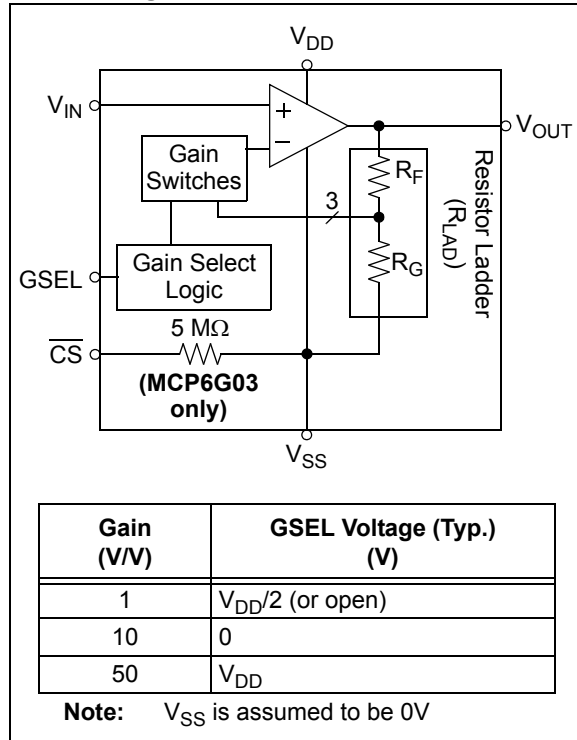

### Description

The Microchip Technology Inc. MCP6G01/1R/1U/2/3/4 are analog Selectable Gain Amplifiers (SGA). They can be configured for gains of +1 V/V, +10 V/V, and +50 V/V through the Gain Select input pin(s). The Chip Select pin on the MCP6G03 can put it into shutdown to conserve power. These SGAs are optimized for single supply applications requiring reasonable quiescent current and speed.

The single amplifiers MCP6G01, MCP6G01R, MCP6G01U, and MCP6G03, are available in 5-pin SOT-23 package and the dual amplifier MCP6G02, are available in 8-pin SOIC and MSOP packages. The quad amplifier MCP6G04 is available in 14-pin SOIC and TSSOP packages. All parts are fully specified from  $-40^{\circ}\text{C}$  to  $+125^{\circ}\text{C}$ .

### Package Types

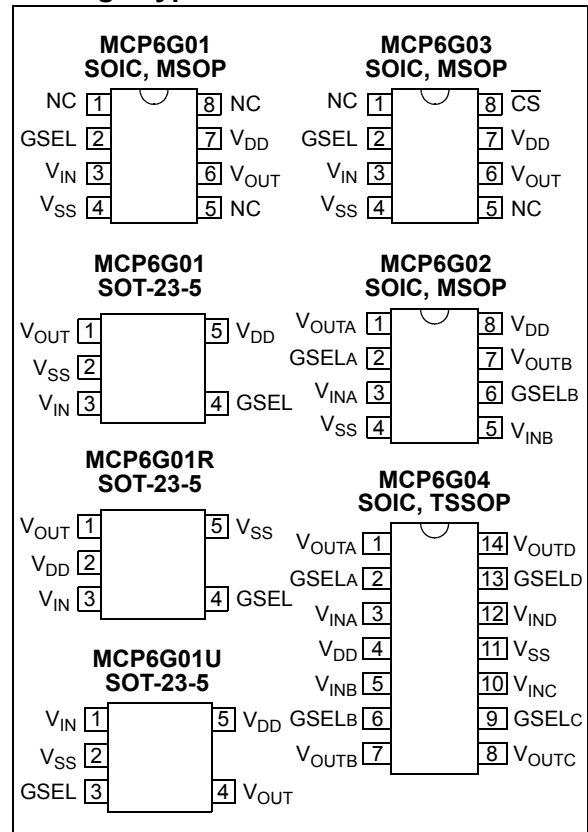

# MCP6G01/1R/1U/2/3/4

## 1.0 ELECTRICAL CHARACTERISTICS

### Absolute Maximum Ratings †

$V_{DD} - V_{SS}$ .....	7.0V
Current at Analog Input Pin ( $V_{IN}$ ) .....	$\pm 2$ mA
Analog Input ( $V_{IN}$ ) †† .....	$V_{SS} - 1.0V$ to $V_{DD} + 1.0V$
All other Inputs and Outputs .....	$V_{SS} - 0.3V$ to $V_{DD} + 0.3V$
Output Short Circuit Current .....	continuous
Current at Output and Supply Pins .....	$\pm 30$ mA
Storage Temperature .....	$-65^{\circ}C$ to $+150^{\circ}C$
Junction Temperature .....	$+150^{\circ}C$
ESD protection on all pins (HBM; MM) .....	$\geq 4$ kV; 200V

† **Notice:** Stresses above those listed under "Absolute Maximum Ratings" may cause permanent damage to the device. This is a stress rating only and functional operation of the device at those or any other conditions above those indicated in the operational listings of this specification is not implied. Exposure to maximum rating conditions for extended periods may affect device reliability.

†† See Section 4.1.4 "Input Voltage and Current Limits".

### DC ELECTRICAL CHARACTERISTICS

Electrical Specifications: Unless otherwise indicated, $T_A = +25^{\circ}C$ , $V_{DD} = +1.8V$ to $+5.5V$ , $V_{SS} = GND$ , $G = +1$ V/V, $V_{IN} = (0.3V)/G$ , $R_L = 100$ k $\Omega$ to $V_{DD}/2$ , $GSEL = V_{DD}/2$ , and CS is tied low.							
Parameters	Sym	Min	Typ	Max	Units	Conditions	
<b>Amplifier Inputs (<math>V_{IN}</math>)</b>							
Input Offset Voltage	$V_{OS}$	-4.5	$\pm 1.0$	+4.5	mV	$G = +1$	
		—	$\pm 1.0$	—	mV	$G = +10, +50$	
Input Offset Voltage Drift	$\Delta V_{OS}/\Delta T_A$	—	$\pm 2$	—	$\mu V/^{\circ}C$	$G = +1$ , $T_A = -40^{\circ}C$ to $+125^{\circ}C$	
Power Supply Rejection Ratio	PSRR	65	80	—	dB	$G = +1$ (Note 1)	
Input Bias Current	$I_B$	—	1	—	pA		
Input Bias Current at Temperature	$I_B$	—	30	—	pA	$T_A = +85^{\circ}C$	
		—	1000	5000	pA	$T_A = +125^{\circ}C$	
Input Impedance	$Z_{IN}$	—	$10^{13}  6$	—	$\Omega  pF$		
<b>Amplifier Gain</b>							
Nominal Gains	G	—	1 to 50	—	V/V	+1, +10 or +50	
DC Gain Error	$g_E$	$G = +1$	-0.3	—	+0.3	%	$V_{OUT} \approx 0.3V$ to $V_{DD} - 0.3V$
		$G \geq +10$	-1.0	—	+1.0	%	$V_{OUT} \approx 0.3V$ to $V_{DD} - 0.3V$
DC Gain Drift	$\Delta G/\Delta T_A$	$G = +1$	—	$\pm 1$	—	ppm/ $^{\circ}C$	$T_A = -40^{\circ}C$ to $+125^{\circ}C$
		$G \geq +10$	—	$\pm 4$	—	ppm/ $^{\circ}C$	$T_A = -40^{\circ}C$ to $+125^{\circ}C$
<b>Ladder Resistance (Note 1)</b>							
Ladder Resistance	$R_{LAD}$	200	350	500	k $\Omega$		
Ladder Resistance across Temperature	$\Delta R_{LAD}/\Delta T_A$	—	-1800	—	ppm/ $^{\circ}C$	$T_A = -40^{\circ}C$ to $+125^{\circ}C$	
<b>Amplifier Output</b>							
DC Output Non-linearity	$V_{ONL}$	$G = +1$	-0.2	—	+0.2	% of FSR	$V_{OUT} = 0.3V$ to $V_{DD} - 0.3V$ , $V_{DD} = 1.8V$
		$G = +10, +50$	-0.1	—	+0.1	% of FSR	$V_{OUT} = 0.3V$ to $V_{DD} - 0.3V$ , $V_{DD} = 5.5V$
DC Output Non-linearity, $G = +10, +50$	$V_{ONL}$	-0.05	—	+0.05	% of FSR	$V_{OUT} = 0.3V$ to $V_{DD} - 0.3V$	
Maximum Output Voltage Swing	$V_{OH}, V_{OL}$	$V_{SS}+10$	—	$V_{DD}-10$	mV	$G = +1$ ; 0.3V output overdrive	
		$V_{SS}+10$	—	$V_{DD}-10$	mV	$G \geq +10$ ; 0.5V output overdrive	
Short Circuit Current	$I_{SC}$	—	$\pm 7$	—	mA	$V_{DD} = 1.8V$	
		—	$\pm 20$	—	mA	$V_{DD} = 5.5V$	

**Note 1:**  $R_{LAD}$  ( $R_F+R_G$  in Figure 4-1) connects  $V_{SS}$ ,  $V_{OUT}$ , and the inverting input of the internal amplifier. Thus,  $V_{SS}$  is coupled to the internal amplifier and the PSRR spec describes PSRR+ only. It is recommended that the  $V_{SS}$  pin be tied directly to ground to avoid noise problems.

**2:**  $I_Q$  includes current in  $R_{LAD}$  (typically 0.6  $\mu A$  at  $V_{OUT} = 0.3V$ ), and excludes digital switching currents.

# MCP6G01/1R/1U/2/3/4

## DC ELECTRICAL CHARACTERISTICS (CONTINUED)

**Electrical Specifications:** Unless otherwise indicated,  $T_A = +25^\circ\text{C}$ ,  $V_{DD} = +1.8\text{V}$  to  $+5.5\text{V}$ ,  $V_{SS} = \text{GND}$ ,  $G = +1 \text{ V/V}$ ,  $V_{IN} = (0.3\text{V})/G$ ,  $R_L = 100 \text{ k}\Omega$  to  $V_{DD}/2$ ,  $GSEL = V_{DD}/2$ , and  $CS$  is tied low.

Parameters	Sym	Min	Typ	Max	Units	Conditions
<b>Power Supply</b>						
Supply Voltage	$V_{DD}$	1.8	—	5.5	V	
Quiescent Current per Amplifier	$I_Q$	60	110	170	$\mu\text{A}$	$I_O = 0$ (Note 2)

**Note 1:**  $R_{LAD}$  ( $R_F + R_G$  in Figure 4-1) connects  $V_{SS}$ ,  $V_{OUT}$ , and the inverting input of the internal amplifier. Thus,  $V_{SS}$  is coupled to the internal amplifier and the PSRR spec describes PSRR+ only. It is recommended that the  $V_{SS}$  pin be tied directly to ground to avoid noise problems.

**2:**  $I_Q$  includes current in  $R_{LAD}$  (typically  $0.6 \mu\text{A}$  at  $V_{OUT} = 0.3\text{V}$ ), and excludes digital switching currents.

## AC ELECTRICAL CHARACTERISTICS

**Electrical Specifications:** Unless otherwise indicated,  $T_A = +25^\circ\text{C}$ ,  $V_{DD} = +1.8\text{V}$  to  $+5.5\text{V}$ ,  $V_{SS} = \text{GND}$ ,  $G = +1 \text{ V/V}$ ,  $V_{IN} = (0.3\text{V})/G$ ,  $R_L = 100 \text{ k}\Omega$  to  $V_{DD}/2$ ,  $C_L = 60 \text{ pF}$ ,  $GSEL = V_{DD}/2$ , and  $CS$  is tied low.

Parameters	Sym	Min	Typ	Max	Units	Conditions
<b>Frequency Response</b>						
-3dB Bandwidth	BW	—	900	—	kHz	$G = +1$ , $V_{OUT} < 100 \text{ mV}_{P-P}$ (Note 1)
	BW	—	350	—	kHz	$G = +10$ , $V_{OUT} < 100 \text{ mV}_{P-P}$ (Note 1)
	BW	—	250	—	kHz	$G = +50$ , $V_{OUT} < 100 \text{ mV}_{P-P}$ (Note 1)
Gain Peaking	GPK	—	0.3	—	dB	$G = +1$ ; $V_{OUT} < 100 \text{ mV}_{P-P}$
	GPK	—	0	—	dB	$G = +10$ , $V_{OUT} < 100 \text{ mV}_{P-P}$
	GPK	—	0.7	—	dB	$G = +50$ ; $V_{OUT} < 100 \text{ mV}_{P-P}$
<b>Total Harmonic Distortion plus Noise</b>						
$f = 1 \text{ kHz}$ , $G = +1 \text{ V/V}$	THD+N	—	0.0029	—	%	$V_{OUT} = 1.75\text{V} \pm 1.4\text{V}_{PK}$ , $V_{DD} = 5.0\text{V}$ , $BW = 80 \text{ kHz}$
$f = 1 \text{ kHz}$ , $G = +10 \text{ V/V}$	THD+N	—	0.18	—	%	$V_{OUT} = 2.5\text{V} \pm 1.4\text{V}_{PK}$ , $V_{DD} = 5.0\text{V}$ , $BW = 80 \text{ kHz}$
$f = 1 \text{ kHz}$ , $G = +50 \text{ V/V}$	THD+N	—	1.3	—	%	$V_{OUT} = 2.5\text{V} \pm 1.4\text{V}_{PK}$ , $V_{DD} = 5.0\text{V}$ , $BW = 80 \text{ kHz}$
<b>Step Response</b>						
Slew Rate	SR	—	0.50	—	$\text{V}/\mu\text{s}$	$G = 1$
	SR	—	2.3	—	$\text{V}/\mu\text{s}$	$G = 10$
	SR	—	4.5	—	$\text{V}/\mu\text{s}$	$G = 50$
<b>Noise</b>						
Input Noise Voltage	$E_{ni}$	—	9	—	$\mu\text{V}_{P-P}$	$f = 0.1 \text{ Hz}$ to $10 \text{ Hz}$ (Note 2)
	$E_{ni}$	—	50	—	$\mu\text{V}_{P-P}$	$f = 0.1 \text{ Hz}$ to $30 \text{ kHz}$ (Note 2)
Input Noise Voltage Density	$e_{ni}$	—	38	—	$\text{nV}/\sqrt{\text{Hz}}$	$G = +1 \text{ V/V}$ , $f = 10 \text{ kHz}$ (Note 2)
	$e_{ni}$	—	46	—	$\text{nV}/\sqrt{\text{Hz}}$	$G = +10 \text{ V/V}$ , $f = 10 \text{ kHz}$ (Note 2)
	$e_{ni}$	—	41	—	$\text{nV}/\sqrt{\text{Hz}}$	$G = +50 \text{ V/V}$ , $f = 10 \text{ kHz}$ (Note 2)
Input Noise Current Density	$i_{ni}$	—	4	—	$\text{fA}/\sqrt{\text{Hz}}$	$f = 10 \text{ kHz}$

**Note 1:** See Table 4-1 for a list of typical numbers and Figure 2-31 for the frequency response versus gain.

**2:**  $E_{ni}$  and  $e_{ni}$  include ladder resistance thermal noise.

# MCP6G01/1R/1U/2/3/4

## DIGITAL ELECTRICAL CHARACTERISTICS

**Electrical Specifications:** Unless otherwise indicated,  $T_A = 25^\circ\text{C}$ ,  $V_{DD} = +1.8\text{V to } +5.5\text{V}$ ,  $V_{SS} = \text{GND}$ ,  $G = +1 \text{ V/V}$ ,  $V_{IN} = (0.3\text{V})/G$ ,  $R_L = 100 \text{ k}\Omega$  to  $V_{DD}/2$ ,  $C_L = 60 \text{ pF}$ ,  $\text{GSEL} = V_{DD}/2$ , and  $\overline{\text{CS}}$  is tied low.

Parameters	Sym	Min	Typ	Max	Units	Conditions
<b>CS Low Specifications</b>						
$\overline{\text{CS}}$ Logic Threshold, Low	$V_{CSL}$	0	—	$0.2V_{DD}$	V	$\overline{\text{CS}} = 0\text{V}$
$\overline{\text{CS}}$ Input Current, Low	$I_{CSL}$	—	30	—	$\mu\text{A}$	$\overline{\text{CS}} = 0\text{V}$
<b>CS High Specifications</b>						
$\overline{\text{CS}}$ Logic Threshold, High	$V_{CSH}$	$0.8V_{DD}$	—	$V_{DD}$	V	$\overline{\text{CS}} = V_{DD}$
$\overline{\text{CS}}$ Input Current, High	$I_{CSH}$	—	0.8	—	$\mu\text{A}$	$\overline{\text{CS}} = V_{DD} = 5.5\text{V}$
Quiescent Current per Amplifier, Shutdown Mode ( $I_{DD}$ )	$I_{DD\_SHDN}$	—	120	—	$\mu\text{A}$	$\overline{\text{CS}} = V_{DD}$ , MCP6G03
Quiescent Current per Amplifier, Shutdown Mode ( $I_{SS}$ ) (Note 3)	$I_{SS\_SHDN}$	—	-2.4	—	$\mu\text{A}$	$\overline{\text{CS}} = V_{DD} = 1.8\text{V}$ , MCP6G03
	$I_{SS\_SHDN}$	—	-7.2	—	$\mu\text{A}$	$\overline{\text{CS}} = V_{DD} = 5.5\text{V}$ , MCP6G03
<b>CS Dynamic Specifications</b>						
Input Capacitance	$C_{CS}$	—	10	—	pF	
Input Rise/Fall Times	$t_{CSRf}$	—	—	2	$\mu\text{s}$	(Note 2)
$\overline{\text{CS}}$ Low to Amplifier Output High Turn-on Time	$t_{CSon}$	—	40	—	$\mu\text{s}$	$G = +1 \text{ V/V}$ , $V_{DD} = 1.8\text{V}$ , $V_{IN} = 0.9V_{DD}$ $\overline{\text{CS}} = 0.2V_{DD}$ to $V_{OUT} = 0.8V_{DD}$
	$t_{CSon}$	—	7	—	$\mu\text{s}$	$G = +1 \text{ V/V}$ , $V_{DD} = 5.5\text{V}$ , $V_{IN} = 0.9V_{DD}$ $\overline{\text{CS}} = 0.2V_{DD}$ to $V_{OUT} = 0.8V_{DD}$
$\overline{\text{CS}}$ High to Amplifier Output High-Z Turn-off Time	$t_{CSoff}$	—	30	—	$\mu\text{s}$	$G = +1 \text{ V/V}$ , $V_{IN} = V_{DD}/2$ , $\overline{\text{CS}} = 0.8V_{DD}$ to $V_{OUT} = 0.1V_{DD}/2$
Hysteresis	$V_{CSHY}$	—	0.40	—	V	$V_{DD} = 1.8\text{V}$
	$V_{CSHY}$	—	0.55	—	V	$V_{DD} = 5.5\text{V}$
<b>GSEL Specifications (Note 1)</b>						
GSEL Logic Threshold, Low	$V_{GSL}$	$0.15V_{DD}$	—	$0.35V_{DD}$	V	Gain changes between 1 and 10, $I_{GSEL} = 0$
GSEL Logic Threshold, High	$V_{GSH}$	$0.65V_{DD}$	—	$0.85V_{DD}$	V	Gain changes between 1 and 50, $I_{GSEL} = 0$
GSEL Input Current, Low	$I_{GSL}$	-10	—	-1.5	$\mu\text{A}$	GSEL voltage = $0.3V_{DD}$
GSEL Input Current, High	$I_{GSH}$	+1.5	—	+10	$\mu\text{A}$	GSEL voltage = $0.7V_{DD}$
<b>GSEL Dynamic Specifications (Note 1)</b>						
Input Capacitance	$C_{GSEL}$	—	8	—	pF	
Input Rise/Fall Times	$t_{GSRf}$	—	—	10	$\mu\text{s}$	(Note 2)
Hysteresis	$V_{GSHY}$	—	45	—	mV	$V_{DD} = 1.8\text{V}$
	$V_{GSHY}$	—	95	—	mV	$V_{DD} = 5.5\text{V}$
GSEL Low to Valid Output Time, $G = +1$ to $+10$ Select	$t_{GSL1}$	—	10	—	$\mu\text{s}$	$V_{IN} = 150 \text{ mV}$ , $GSEL = 0.25V_{DD}$ to $V_{OUT} = 1.37\text{V}$
GSEL Middle to Valid Output Time, $G = +10$ to $+1$ Select	$t_{GSM10}$	—	12	—	$\mu\text{s}$	$V_{IN} = 150 \text{ mV}$ , $GSEL = 0.25V_{DD}$ to $V_{OUT} = 0.28\text{V}$
GSEL High to Valid Output Time, $G = +1$ to $+50$ Select	$t_{GSH1}$	—	9	—	$\mu\text{s}$	$V_{IN} = 30 \text{ mV}$ , $GSEL = 0.75V_{DD}$ to $V_{OUT} = 1.35\text{V}$
GSEL Middle to Valid Output Time, $G = +50$ to $+1$ Select	$t_{GSM50}$	—	8	—	$\mu\text{s}$	$V_{IN} = 30 \text{ mV}$ , $GSEL = 0.75V_{DD}$ to $V_{OUT} = 0.18\text{V}$

- Note 1:** GSEL is a tri-level input pin. The gain is 10 when its voltage is low, 1 when it is at mid-supply, and 50 when it is high.  
**Note 2:** Not tested in production. Set by design and characterization.  
**Note 3:**  $I_{SS\_SHDN}$  includes the current through the  $\overline{\text{CS}}$  pin,  $R_L$  and  $R_{LAD}$ , and excludes digital switching currents. The block diagram on the front page shows these current paths (through  $V_{SS}$ ).

# MCP6G01/1R/1U/2/3/4

## DIGITAL ELECTRICAL CHARACTERISTICS (CONTINUED)

**Electrical Specifications:** Unless otherwise indicated,  $T_A = 25^\circ\text{C}$ ,  $V_{DD} = +1.8\text{V}$  to  $+5.5\text{V}$ ,  $V_{SS} = \text{GND}$ ,  $G = +1 \text{ V/V}$ ,  $V_{IN} = (0.3\text{V})/G$ ,  $R_L = 100 \text{ k}\Omega$  to  $V_{DD}/2$ ,  $C_L = 60 \text{ pF}$ ,  $\text{GSEL} = V_{DD}/2$ , and  $\overline{\text{CS}}$  is tied low.

Parameters	Sym	Min	Typ	Max	Units	Conditions
GSEL High to Valid Output Time, $G = +10$ to $+50$ Select	$t_{\text{GSH}10}$	—	12	—	$\mu\text{s}$	$V_{IN} = 30 \text{ mV}$ , $\text{GSEL} = 0.75V_{DD}$ to $V_{OUT} = 1.38\text{V}$
GSEL Low to Valid Output Time, $G = +50$ to $+10$ Select	$t_{\text{GSL}50}$	—	9	—	$\mu\text{s}$	$V_{IN} = 30 \text{ mV}$ , $\text{GSEL} = 0.25V_{DD}$ to $V_{OUT} = 0.42\text{V}$

- Note 1:** GSEL is a tri-level input pin. The gain is 10 when its voltage is low, 1 when it is at mid-supply, and 50 when it is high.  
**Note 2:** Not tested in production. Set by design and characterization.  
**Note 3:**  $I_{SS\_SHDN}$  includes the current through the  $\overline{\text{CS}}$  pin,  $R_L$  and  $R_{LAD}$ , and excludes digital switching currents. The block diagram on the from page shows these current paths (through  $V_{SS}$ ).

## TEMPERATURE CHARACTERISTICS

**Electrical Specifications:** Unless otherwise indicated,  $V_{DD} = +1.8\text{V}$  to  $+5.5\text{V}$ , and  $V_{SS} = \text{GND}$ .

Parameters	Sym	Min	Typ	Max	Units	Conditions
<b>Temperature Ranges</b>						
Specified Temperature Range	$T_A$	-40	—	+125	$^\circ\text{C}$	
Operating Temperature Range	$T_A$	-40	—	+125	$^\circ\text{C}$	(Note 1)
Storage Temperature Range	$T_A$	-65	—	+150	$^\circ\text{C}$	
<b>Thermal Package Resistances</b>						
Thermal Resistance, 5L-SOT-23	$\theta_{JA}$	—	256	—	$^\circ\text{C/W}$	
Thermal Resistance, 8L-SOIC	$\theta_{JA}$	—	163	—	$^\circ\text{C/W}$	
Thermal Resistance, 8L-MSOP	$\theta_{JA}$	—	206	—	$^\circ\text{C/W}$	
Thermal Resistance, 14L-SOIC	$\theta_{JA}$	—	120	—	$^\circ\text{C/W}$	
Thermal Resistance, 14L-TSSOP	$\theta_{JA}$	—	100	—	$^\circ\text{C/W}$	

- Note 1:** The MCP6G01/1R/1U/2/3/4 family of SGAs operates over this temperature range, but operation must not cause  $T_J$  to exceed Maximum Junction Temperature ( $+150^\circ\text{C}$ ).

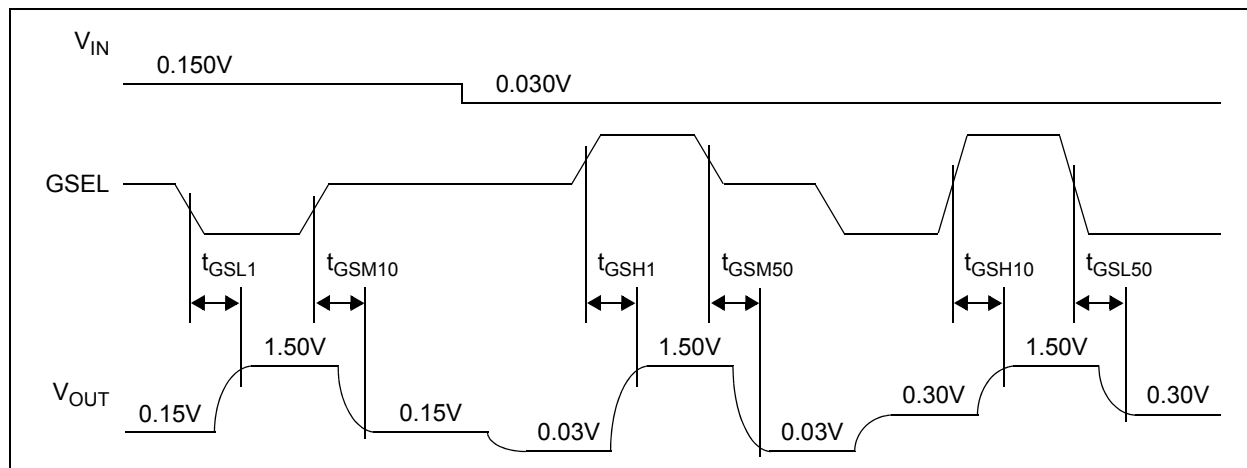

**FIGURE 1-1:** Gain Select Timing Diagram.

# MCP6G01/1R/1U/2/3/4

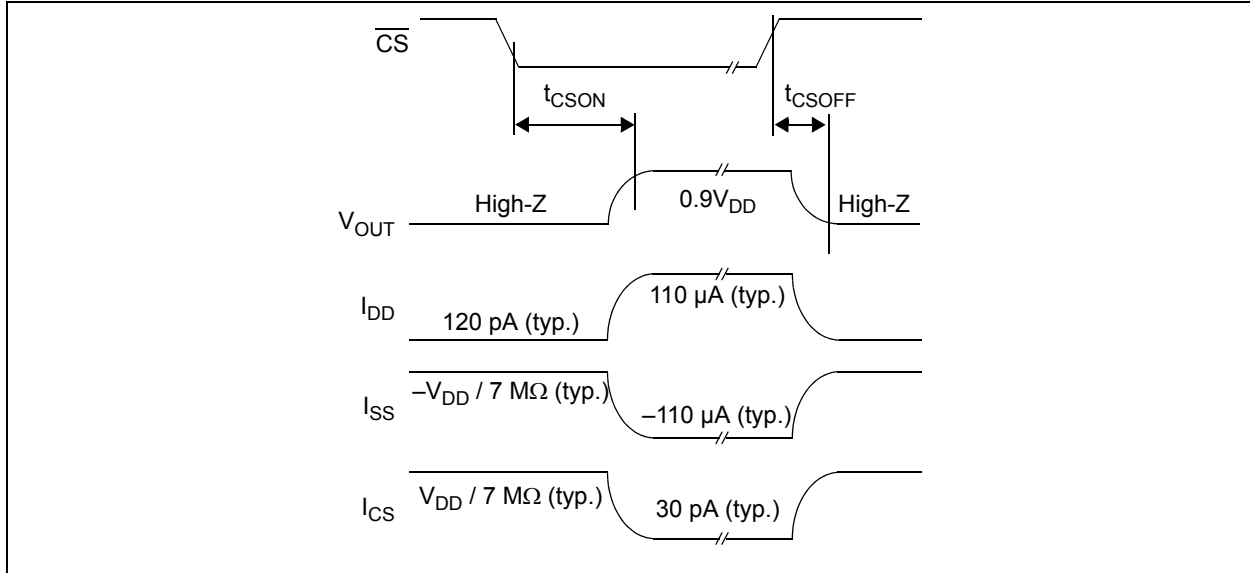

**FIGURE 1-2:** SGA Chip Select Timing Diagram.

## 1.1 DC Output Voltage Specs / Model

### 1.1.1 IDEAL MODEL

The ideal SGA output voltage ( $V_{OUT}$ ) is (see [Figure 1-3](#)):

#### EQUATION 1-1:

$$V_{O\_ID} = GV_{IN}$$

Where:

G is the nominal gain

$$V_{REF} = V_{SS} = 0V$$

This equation holds when there are no gain or offset errors.

### 1.1.2 LINEAR MODEL

The SGA's linear region of operation is modeled by the line  $V_{O\_LIN}$  shown in [Figure 1-3](#).  $V_{O\_LIN}$  includes offset and gain errors, but does not include non-linear effects.

#### EQUATION 1-2:

$$V_{O\_LIN} = G(1 + g_E) \left( V_{IN} - \frac{0.3V}{G} + V_{OS} \right) + 0.3V$$

Where:

G is the nominal gain

$g_E$  is the gain error

$V_{OS}$  is the input offset voltage

$$V_{REF} = V_{SS} = 0V$$

This line's endpoints are 0.3V from the supply rails ( $V_{O\_ID} = 0.3V$  and  $V_{DD} - 0.3V$ ). The gain error and input offset voltage specifications (in the electrical specifications) relate to [Figure 1-3](#) as follows:

#### EQUATION 1-3:

$$g_E = 100\% \cdot \frac{V_2 - V_1}{V_{DD} - 0.6V}$$

$$V_{OS} = \frac{V_1}{G(1 + g_E)}, \quad G = +1$$

Where:

$$V_1 = V_{OUT} - V_{O\_ID}, \quad V_{O\_ID} = 0.3V$$

$$V_2 = V_{OUT} - V_{O\_ID}, \quad V_{O\_ID} = V_{DD} - 0.3V$$

The input offset specification describes  $V_{OS}$  at  $G = +1$  V/V.

The DC Gain Drift ( $\Delta G/\Delta T_A$ ) can be calculated from the change in  $g_E$  across temperature. This is shown in the following equation:

#### EQUATION 1-4:

$$\Delta G/\Delta T_A = G \cdot \frac{\Delta g_E}{\Delta T_A}, \quad \text{in units of V/V/}^\circ\text{C}$$

$$\Delta G/\Delta T_A = 100\% \cdot \frac{\Delta g_E}{\Delta T_A}, \quad \text{in units of \%}/^\circ\text{C}$$

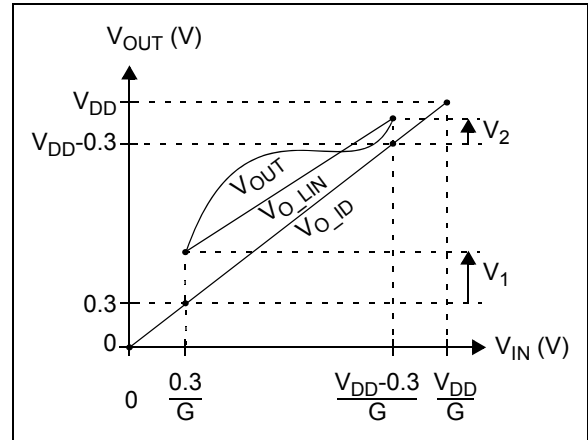

**FIGURE 1-3:** Output Voltage Model.

### 1.1.3 OUTPUT NON-LINEARITY

[Figure 1-4](#) shows the Integral Non-Linearity (INL) of the output voltage. INL is the output non-linearity error not explained by  $V_{O\_LIN}$ :

#### EQUATION 1-5:

$$INL = V_{OUT} - V_{O\_LIN}$$

The output non-linearity specification (in the Electrical Specifications, with units of % of FSR) is related to [Figure 1-4](#) by:

#### EQUATION 1-6:

$$V_{ONL} = 100\% \cdot \frac{\max(V_3, V_4)}{V_{DD} - 0.6V}$$

Where:

$$V_3 = \max(-INL)$$

$$V_4 = \max(INL)$$

Note that the Full Scale Range (FSR) is  $V_{DD} - 0.6V$  (0.3V to  $V_{DD} - 0.3V$ ).

# MCP6G01/1R/1U/2/3/4

---

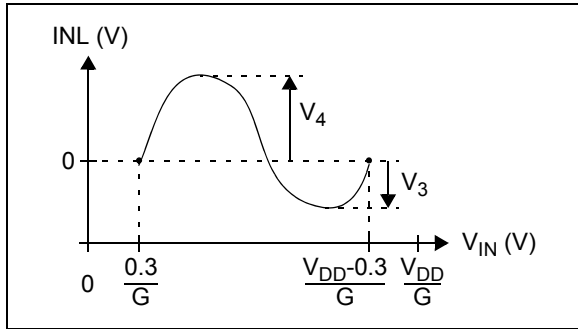

**FIGURE 1-4:** Output Voltage INL.



## 2.0 TYPICAL PERFORMANCE CURVES

**Note:** The graphs and tables provided following this note are a statistical summary based on a limited number of samples and are provided for informational purposes only. The performance characteristics listed herein are not tested or guaranteed. In some graphs or tables, the data presented may be outside the specified operating range (e.g., outside specified power supply range) and therefore outside the warranted range.

**Note:** Unless otherwise indicated,  $T_A = +25^\circ\text{C}$ ,  $V_{DD} = +1.8\text{V to } +5.5\text{V}$ ,  $V_{SS} = \text{GND}$ ,  $G = +1\text{ V/V}$ ,  $V_{IN} = (0.3\text{V})/G$ ,  $R_L = 100\text{ k}\Omega\text{ to } V_{DD}/2$ ,  $C_L = 60\text{ pF}$ ,  $\text{GSEL} = V_{DD}/2$ , and CS is tied low.

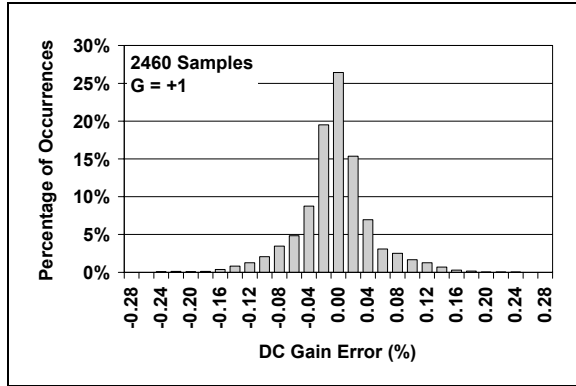

FIGURE 2-1: DC Gain Error, G = +1.

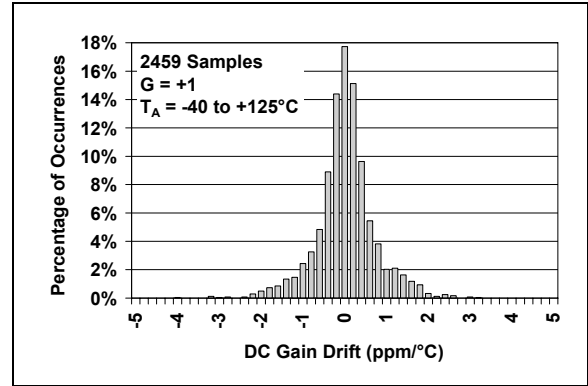

FIGURE 2-4: DC Gain Drift, G = +1.

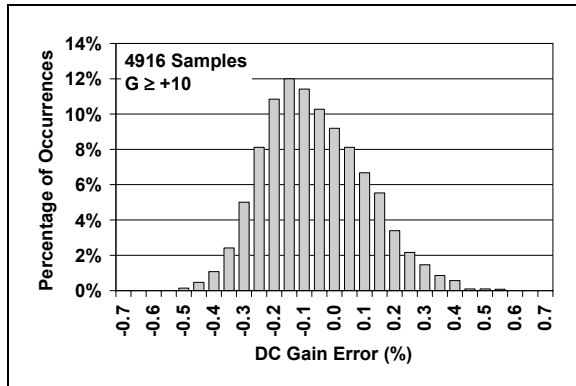

FIGURE 2-2: DC Gain Error, G ≥ +10.

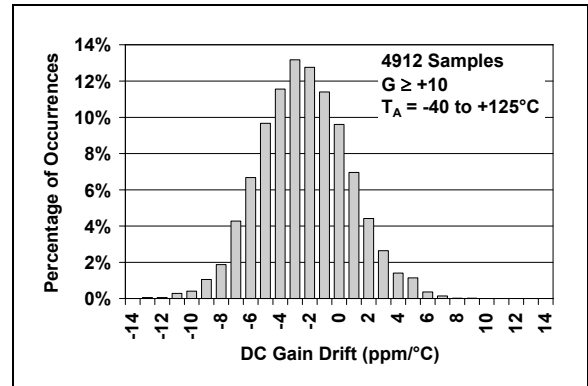

FIGURE 2-5: DC Gain Drift, G ≥ +10.

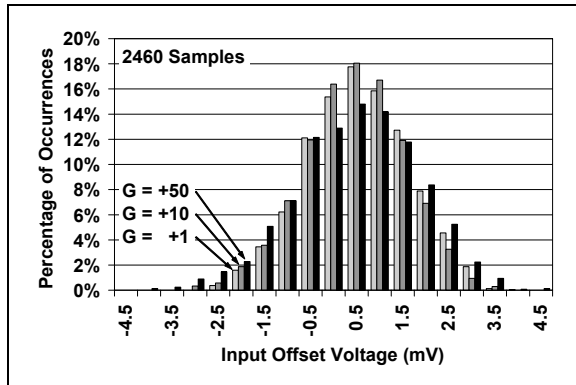

FIGURE 2-3: Input Offset Voltage.

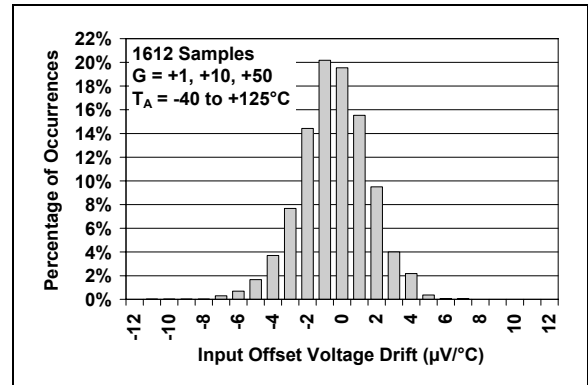
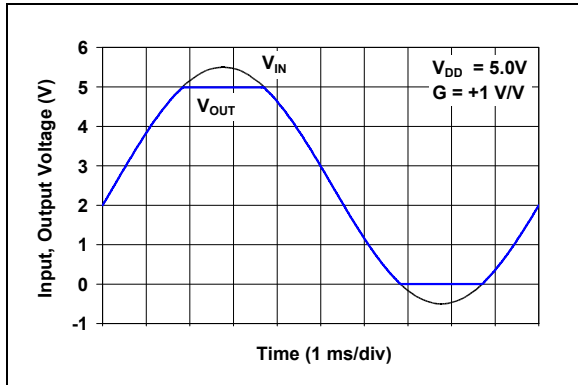

FIGURE 2-6: Input Offset Voltage Drift.

# MCP6G01/1R/1U/2/3/4

**Note:** Unless otherwise indicated,  $T_A = +25^\circ\text{C}$ ,  $V_{DD} = +1.8\text{V}$  to  $+5.5\text{V}$ ,  $V_{SS} = \text{GND}$ ,  $G = +1\text{ V/V}$ ,  $V_{IN} = (0.3\text{V})/G$ ,  $R_L = 100\text{ k}\Omega$  to  $V_{DD}/2$ ,  $C_L = 60\text{ pF}$ ,  $\text{GSEL} = V_{DD}/2$ , and CS is tied low.



**FIGURE 2-7:** The MCP6G01/1R/1U/2/3/4 family shows no phase reversal under overdrive.

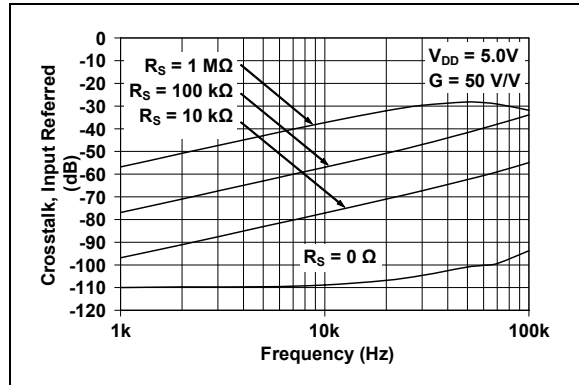

**FIGURE 2-10:** Crosstalk vs. Frequency, with  $G = 50$  (circuit in Figure 4-7).

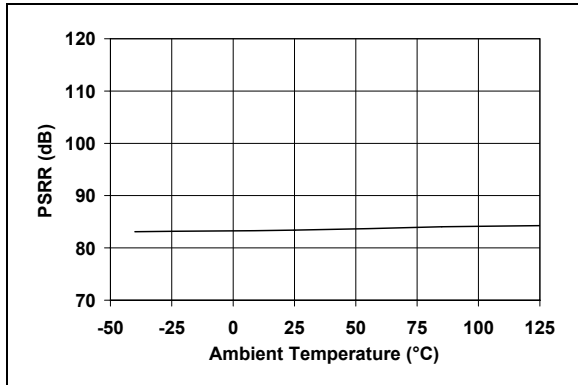

**FIGURE 2-8:** PSRR vs. Temperature.

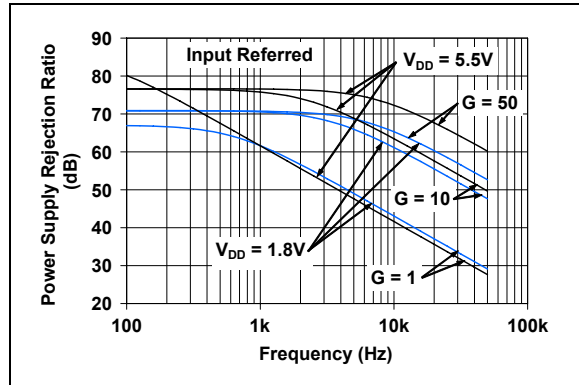

**FIGURE 2-11:** PSRR vs. Frequency.

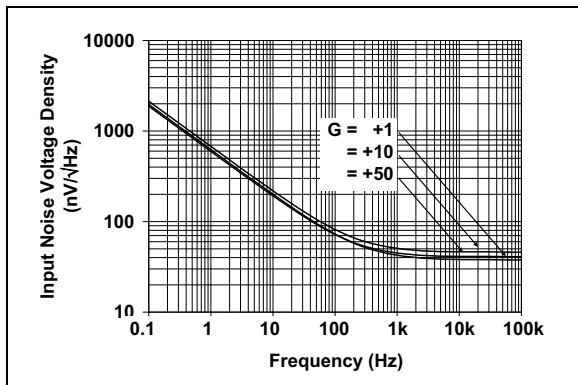

**FIGURE 2-9:** Input Noise Voltage Density vs. Frequency.

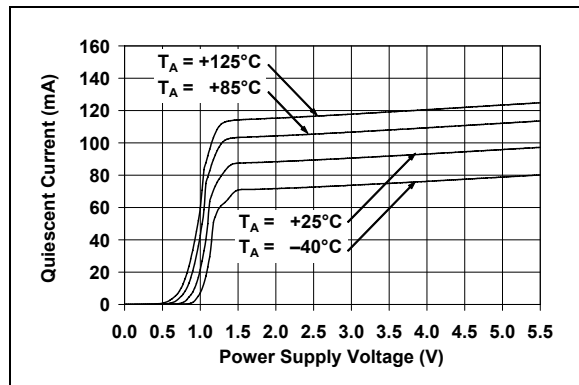

**FIGURE 2-12:** Quiescent Current vs. Supply Voltage.

# MCP6G01/1R/1U/2/3/4

**Note:** Unless otherwise indicated,  $T_A = +25^\circ\text{C}$ ,  $V_{DD} = +1.8\text{V}$  to  $+5.5\text{V}$ ,  $V_{SS} = \text{GND}$ ,  $G = +1\text{ V/V}$ ,  $V_{IN} = (0.3\text{V})/G$ ,  $R_L = 100\text{ k}\Omega$  to  $V_{DD}/2$ ,  $C_L = 60\text{ pF}$ ,  $\text{GSEL} = V_{DD}/2$ , and  $\text{CS}$  is tied low.

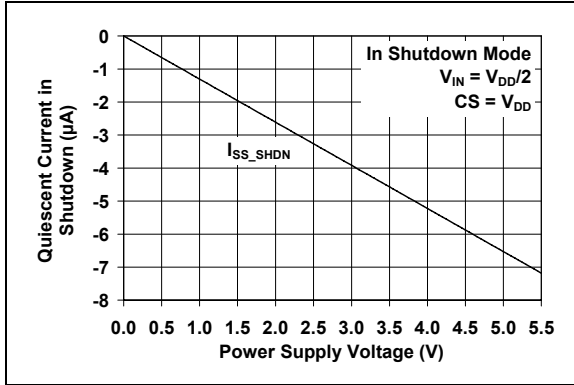

**FIGURE 2-13:** Quiescent Current ( $I_{SS}$ ) in Shutdown Mode vs. Supply Voltage.

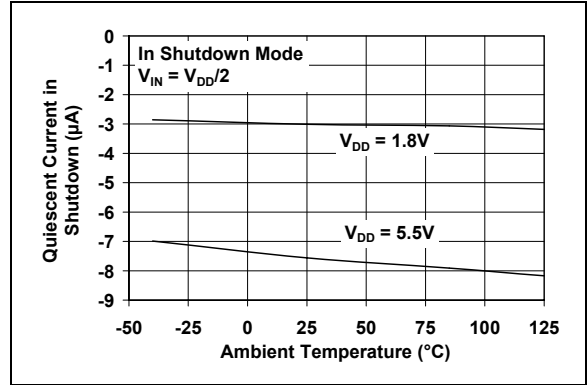

**FIGURE 2-16:** Quiescent Current ( $I_{SS}$ ) in Shutdown Mode vs. Temperature.

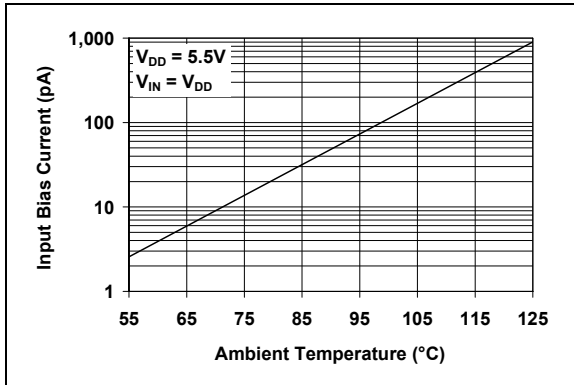

**FIGURE 2-14:** Input Bias Current vs. Temperature.

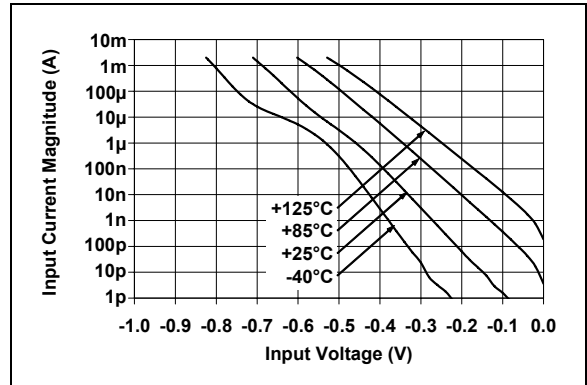

**FIGURE 2-17:** Input Bias Current vs. Input Voltage.

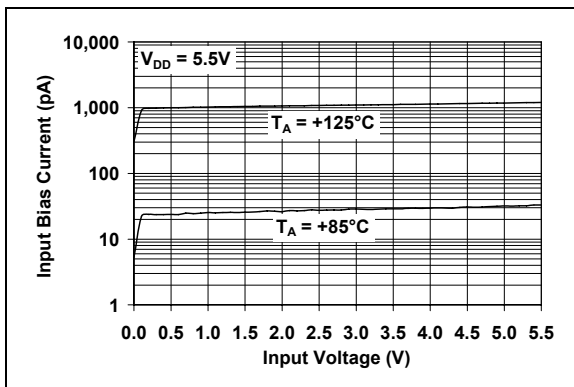

**FIGURE 2-15:** Input Bias Current vs. Input Voltage.

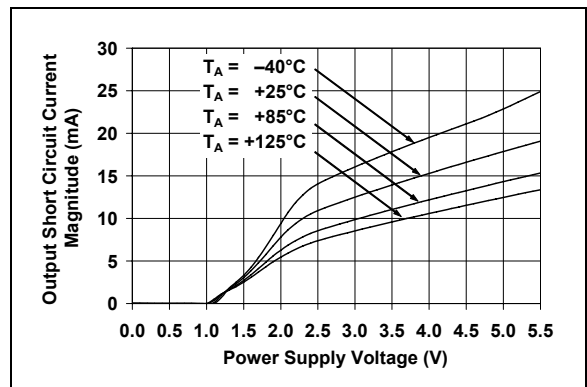

**FIGURE 2-18:** Output Short Circuit Current vs. Supply Voltage.

# MCP6G01/1R/1U/2/3/4

**Note:** Unless otherwise indicated,  $T_A = +25^\circ\text{C}$ ,  $V_{DD} = +1.8\text{V}$  to  $+5.5\text{V}$ ,  $V_{SS} = \text{GND}$ ,  $G = +1 \text{ V/V}$ ,  $V_{IN} = (0.3\text{V})/G$ ,  $R_L = 100 \text{ k}\Omega$  to  $V_{DD}/2$ ,  $C_L = 60 \text{ pF}$ ,  $\text{GSEL} = V_{DD}/2$ , and  $\text{CS}$  is tied low.

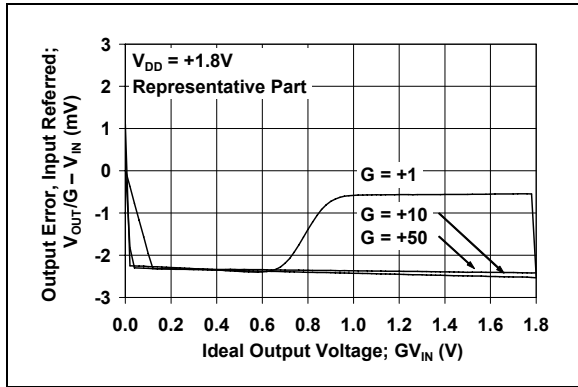

**FIGURE 2-19:** Output Voltage Error vs. Ideal Output Voltage, with  $V_{DD} = 1.8\text{V}$ .

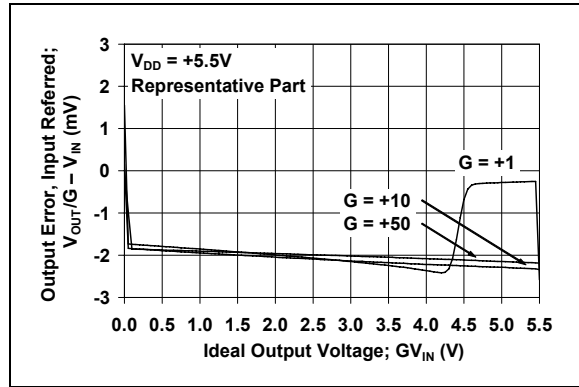

**FIGURE 2-22:** Output Voltage Error vs. Ideal Output Voltage, with  $V_{DD} = 5.5\text{V}$ .

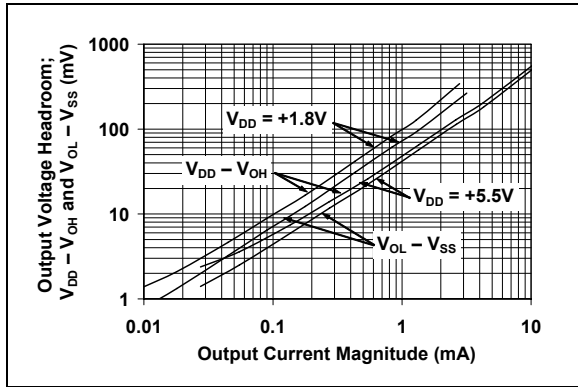

**FIGURE 2-20:** Output Voltage Headroom vs. Output plus Ladder Current (circuit in Figure 4-4).

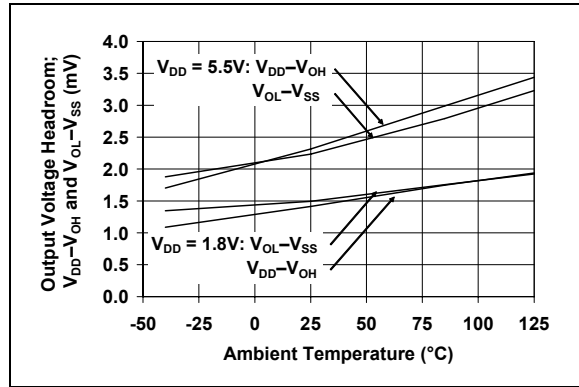

**FIGURE 2-23:** Output Voltage Headroom vs. Temperature.

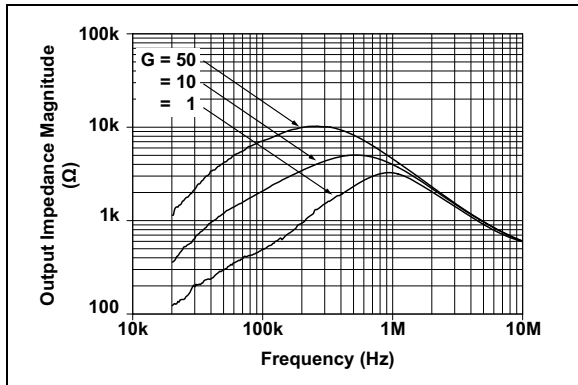

**FIGURE 2-21:** Output Impedance vs. Frequency.

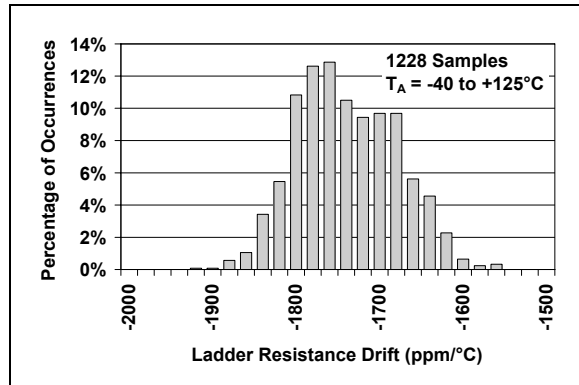

**FIGURE 2-24:** Ladder Resistance Drift.

# MCP6G01/1R/1U/2/3/4

**Note:** Unless otherwise indicated,  $T_A = +25^\circ\text{C}$ ,  $V_{DD} = +1.8\text{V}$  to  $+5.5\text{V}$ ,  $V_{SS} = \text{GND}$ ,  $G = +1\text{ V/V}$ ,  $V_{IN} = (0.3\text{V})/G$ ,  $R_L = 100\text{ k}\Omega$  to  $V_{DD}/2$ ,  $C_L = 60\text{ pF}$ ,  $\text{GSEL} = V_{DD}/2$ , and  $\text{CS}$  is tied low.

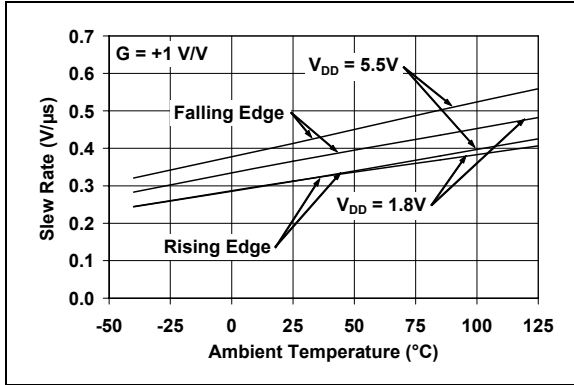

**FIGURE 2-25:** Slew Rate vs. Temperature, with  $G = +1$ .

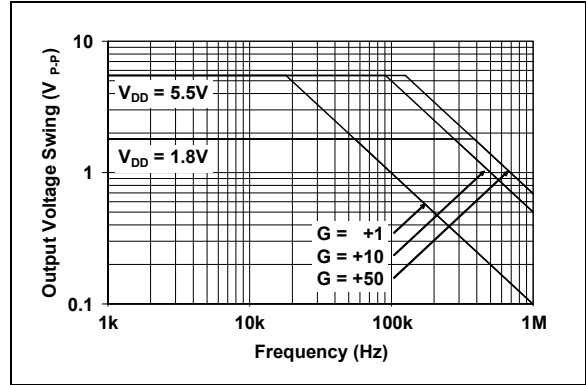

**FIGURE 2-28:** Output Voltage Swing vs. Frequency.

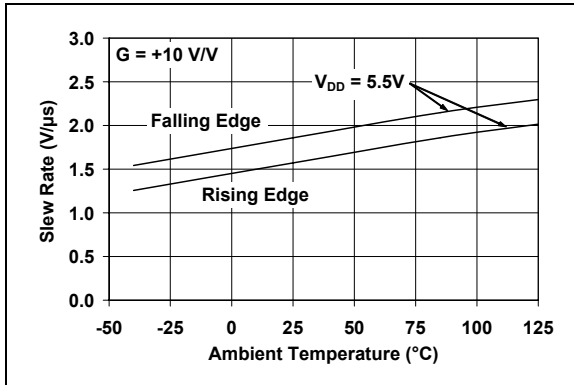

**FIGURE 2-26:** Slew Rate vs. Temperature, with  $G = +10$ .

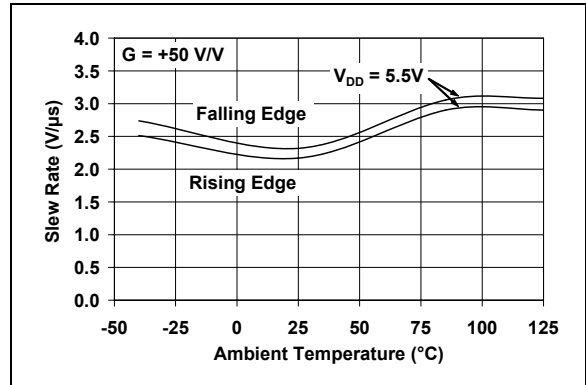

**FIGURE 2-29:** Slew Rate vs. Temperature, with  $G = +50$ .

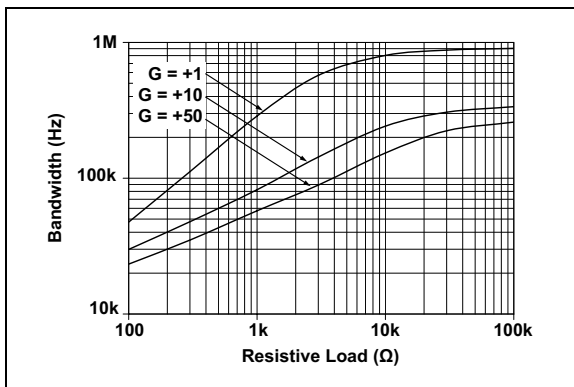

**FIGURE 2-27:** Bandwidth vs. Resistive Load.

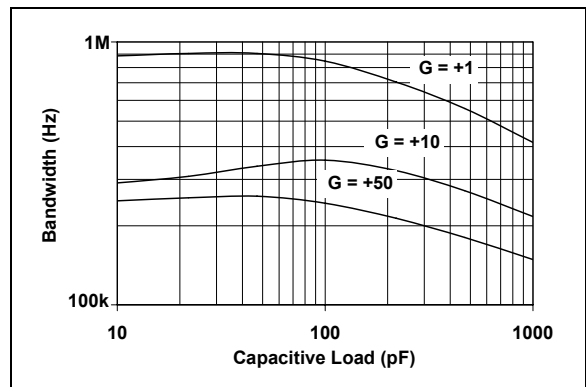

**FIGURE 2-30:** Bandwidth vs. Capacitive Load.

# MCP6G01/1R/1U/2/3/4

**Note:** Unless otherwise indicated,  $T_A = +25^\circ\text{C}$ ,  $V_{DD} = +1.8\text{V}$  to  $+5.5\text{V}$ ,  $V_{SS} = \text{GND}$ ,  $G = +1\text{ V/V}$ ,  $V_{IN} = (0.3\text{V})/G$ ,  $R_L = 100\text{ k}\Omega$  to  $V_{DD}/2$ ,  $C_L = 60\text{ pF}$ ,  $\text{GSEL} = V_{DD}/2$ , and  $\text{CS}$  is tied low.

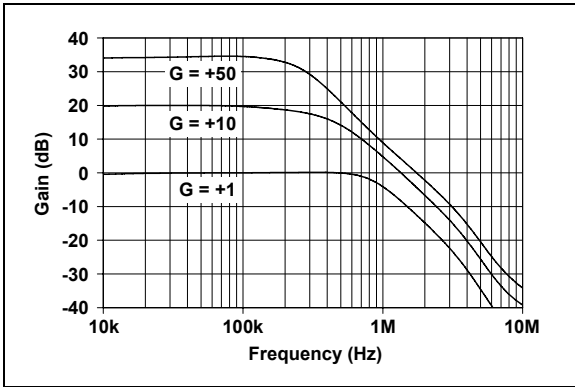

**FIGURE 2-31:** Gain vs. Frequency.

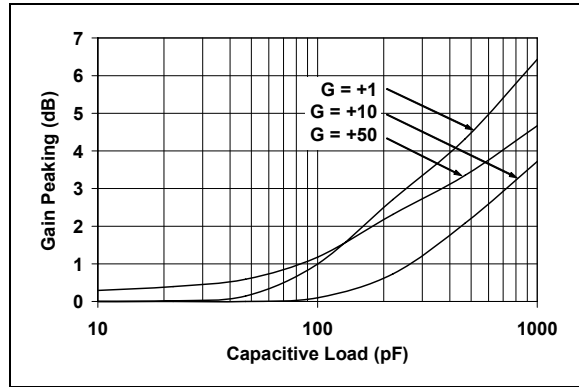

**FIGURE 2-34:** Gain Peaking vs. Capacitive Load.

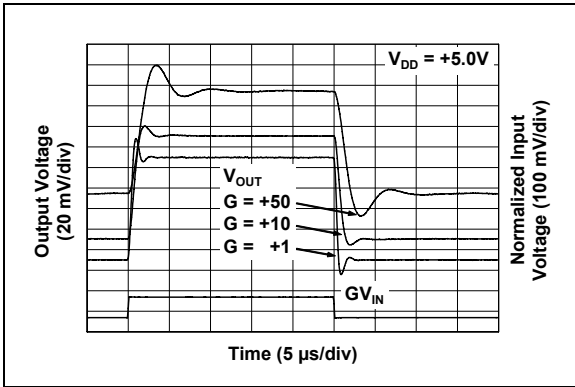

**FIGURE 2-32:** Small Signal Pulse Response.

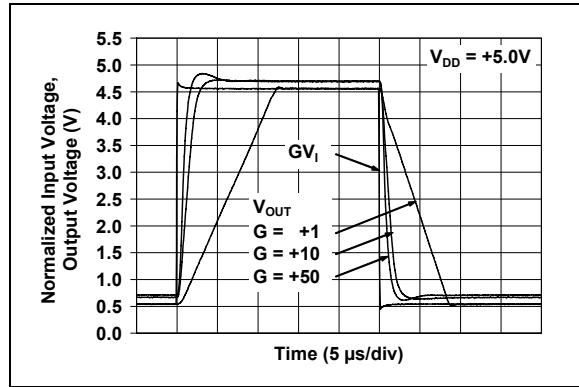

**FIGURE 2-35:** Large Signal Pulse Response.

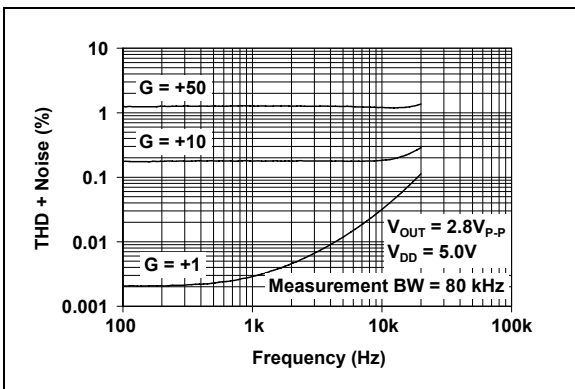

**FIGURE 2-33:** THD plus Noise vs. Frequency,  $V_{OUT} = 2.8\text{ V}_{P-P}$

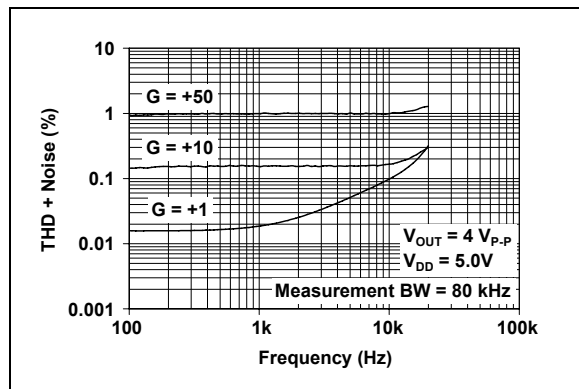

**FIGURE 2-36:** THD plus Noise vs. Frequency,  $V_{OUT} = 4.0\text{ V}_{P-P}$

# MCP6G01/1R/1U/2/3/4

**Note:** Unless otherwise indicated,  $T_A = +25^\circ\text{C}$ ,  $V_{DD} = +1.8\text{V}$  to  $+5.5\text{V}$ ,  $V_{SS} = \text{GND}$ ,  $G = +1\text{ V/V}$ ,  $V_{IN} = (0.3\text{V})/G$ ,  $R_L = 100\text{ k}\Omega$  to  $V_{DD}/2$ ,  $C_L = 60\text{ pF}$ ,  $\text{GSEL} = V_{DD}/2$ , and  $\text{CS}$  is tied low.

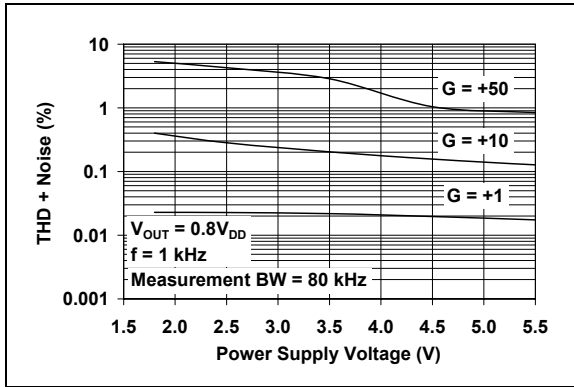

**FIGURE 2-37:** THD plus Noise vs. Supply Voltage.

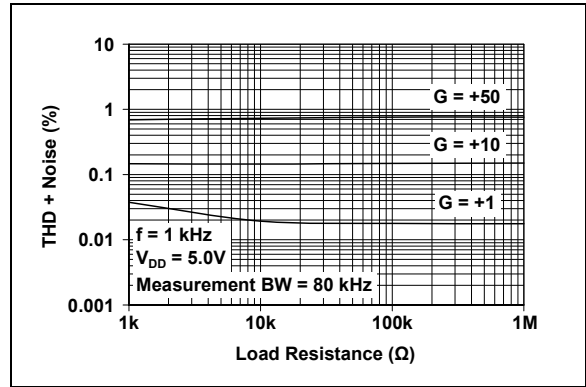

**FIGURE 2-40:** THD plus Noise vs. Load Resistance.

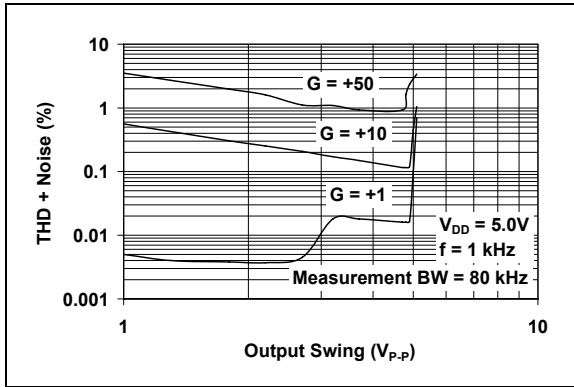

**FIGURE 2-38:** THD plus Noise vs. Output Swing.

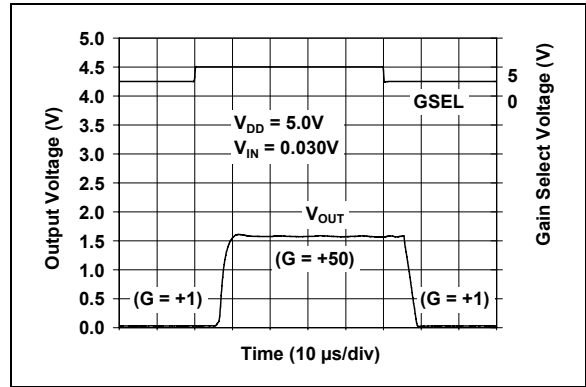

**FIGURE 2-41:** Gain Select Timing, with Gain = 1 and 50.

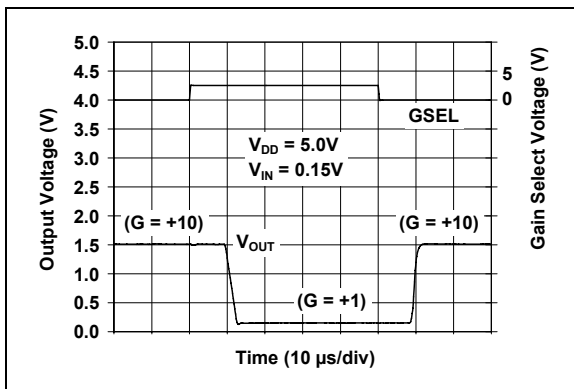

**FIGURE 2-39:** Gain Select Timing, with Gain = 1 and 10.

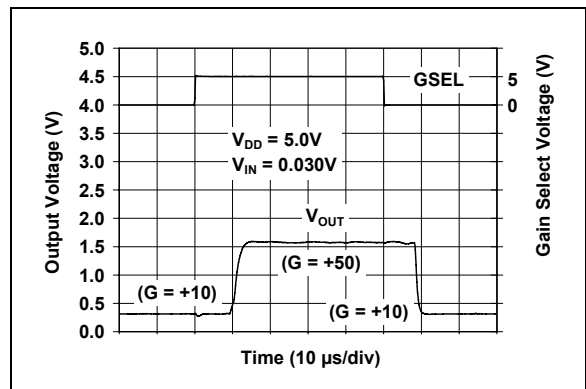

**FIGURE 2-42:** Gain Select Timing, with Gain = 1 and 10.

# MCP6G01/1R/1U/2/3/4

**Note:** Unless otherwise indicated,  $T_A = +25^\circ\text{C}$ ,  $V_{DD} = +1.8\text{V}$  to  $+5.5\text{V}$ ,  $V_{SS} = \text{GND}$ ,  $G = +1\text{ V/V}$ ,  $V_{IN} = (0.3\text{V})/G$ ,  $R_L = 100\text{ k}\Omega$  to  $V_{DD}/2$ ,  $C_L = 60\text{ pF}$ ,  $\text{GSEL} = V_{DD}/2$ , and CS is tied low.

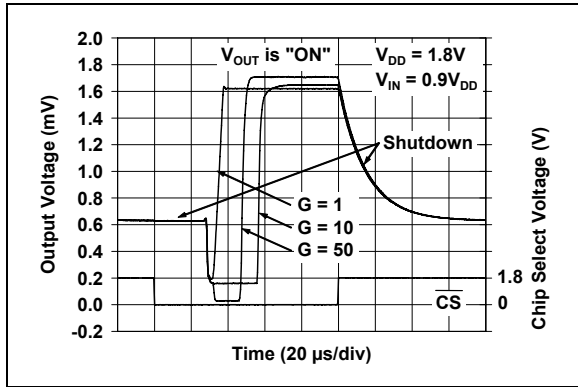

**FIGURE 2-43:** Output Voltage vs. Chip Select, with  $V_{DD} = 1.8\text{V}$ .

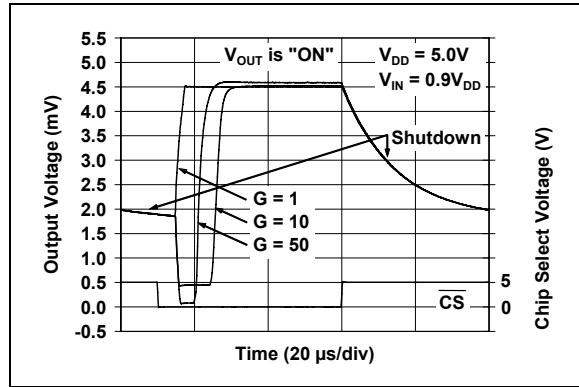

**FIGURE 2-46:** Output Voltage vs. Chip Select, with  $V_{DD} = 5.0\text{V}$ .

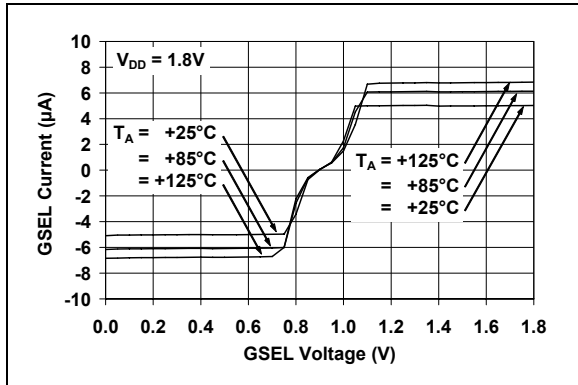

**FIGURE 2-44:** GSEL Pin Current vs. GSEL Voltage, with  $V_{DD} = 1.8\text{V}$ .

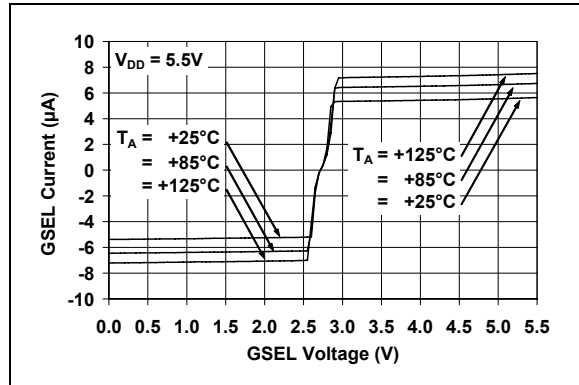

**FIGURE 2-47:** GSEL Pin Current vs. GSEL Voltage, with  $V_{DD} = 5.5\text{V}$ .

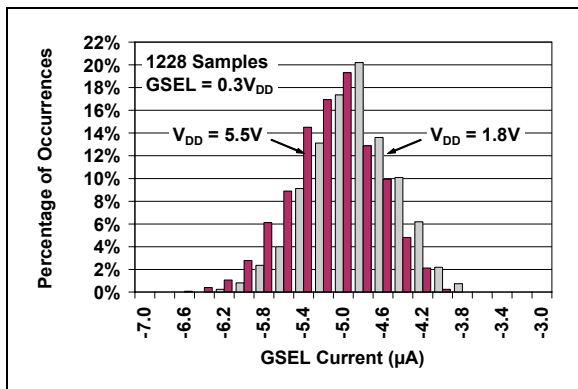

**FIGURE 2-45:** GSEL Current, with GSEL Voltage of  $0.3V_{DD}$ .

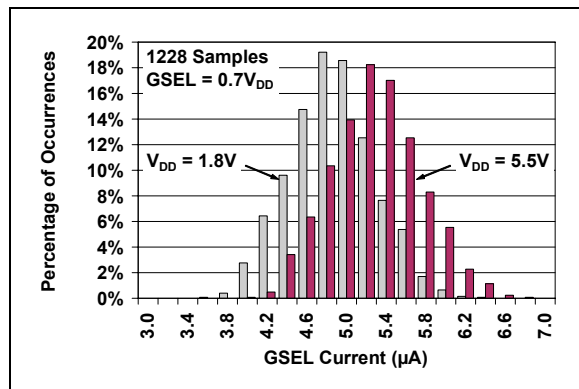
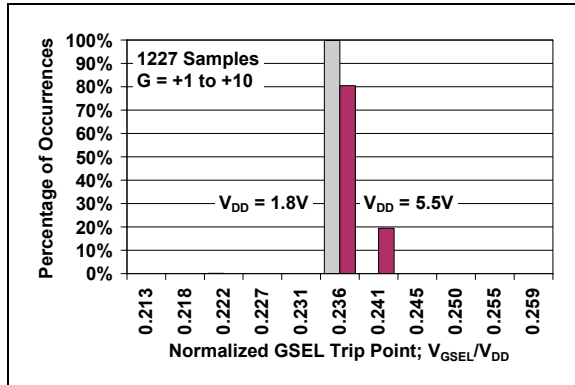

**FIGURE 2-48:** GSEL Current, with GSEL Voltage of  $0.7V_{DD}$ .



# MCP6G01/1R/1U/2/3/4

**Note:** Unless otherwise indicated,  $T_A = +25^\circ\text{C}$ ,  $V_{DD} = +1.8\text{V}$  to  $+5.5\text{V}$ ,  $V_{SS} = \text{GND}$ ,  $G = +1\text{ V/V}$ ,  $V_{IN} = (0.3\text{V})/G$ ,  $R_L = 100\text{ k}\Omega$  to  $V_{DD}/2$ ,  $C_L = 60\text{ pF}$ ,  $\text{GSEL} = V_{DD}/2$ , and CS is tied low.



**FIGURE 2-49:** GSEL Trip Point between  $G = +1$  and  $G = +10$ .

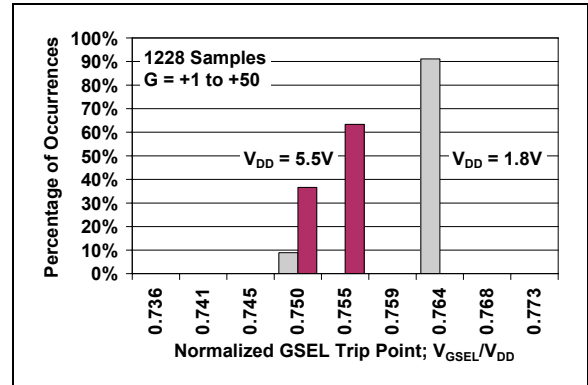

**FIGURE 2-50:** GSEL Trip Point between  $G = +1$  and  $G = +50$ .

# MCP6G01/1R/1U/2/3/4

## 3.0 PIN DESCRIPTIONS

Descriptions of the pins are listed in Table 3-1 (single op amps) and Table 3-2 (dual and quad op amps).

TABLE 3-1: PIN FUNCTION TABLE FOR SINGLE OP AMPS

MCP6G01 (SOIC, MSOP)	MCP6G01 (SOT-23-5)	MCP6G01R (SOT-23-5)	MCP6G01U (SOT-23-5)	MCP6G03	Symbol	Description
6	1	1	4	6	$V_{OUT}$	Analog Output
2	4	4	3	2	GSEL	Gain Select Input
3	3	3	1	3	$V_{IN}$	Analog Input
7	5	2	5	7	$V_{DD}$	Positive Power Supply
4	2	5	2	4	$V_{SS}$	Negative Power Supply
—	—	—	—	8	$\overline{CS}$	Chip Select
1,5,8	—	—	—	1,5	NC	No Internal Connection

TABLE 3-2: PIN FUNCTION TABLE FOR DUAL AND QUAD OP AMPS

MCP6G02	MCP6G04	Symbol	Description
1	1	$V_{OUTA}$	Analog Output A
2	2	$GSEL_A$	Gain Select Input (SGA A)
3	3	$V_{INA}$	Analog Input A
8	4	$V_{DD}$	Positive Power Supply
5	5	$V_{INB}$	Analog Input B
6	6	$GSEL_B$	Gain Select Input (SGA B)
7	7	$V_{OUTB}$	Analog Output B
—	8	$V_{OUTC}$	Analog Output C
—	9	$GSEL_C$	Gain Select Input (SGA C)
—	10	$V_{INC}$	Analog Input C
4	11	$V_{SS}$	Negative Power Supply
—	12	$V_{IND}$	Analog Input D
—	13	$GSEL_D$	Gain Select Input (SGA D)
—	14	$V_{OUTD}$	Analog Output D

### 3.1 Analog Output

The output pin ( $V_{OUT}$ ) is a low impedance voltage source. The selected gain ( $G$ ) and input voltage ( $V_{IN}$ ) determine its value.

### 3.2 Analog Input

The analog inputs ( $V_{IN}$ ) are high impedance CMOS inputs with low bias currents. Only three fixed, non-inverting gains are available through these inputs.

### 3.3 Power Supply ( $V_{SS}$ and $V_{DD}$ )

The Positive Power Supply Pin ( $V_{DD}$ ) is 1.8V to 5.5V higher than the Negative Power Supply Pin ( $V_{SS}$ ). For normal operation, the other pins are at voltages between  $V_{SS}$  and  $V_{DD}$ .

Typically, these parts are used in a single (positive) supply configuration. In this case,  $V_{SS}$  is connected to ground, and  $V_{DD}$  is connected to the supply.  $V_{DD}$  will need a local bypass capacitor (typically 0.01  $\mu$ F to 0.1  $\mu$ F) within 2 mm of the  $V_{DD}$  pin. These parts need to use a bulk capacitor (typically 1.0  $\mu$ F to 10  $\mu$ F) within 100 mm of the  $V_{DD}$  pin; it can be shared with nearby analog parts.

### 3.4 Digital Inputs

The Chip Select ( $\overline{CS}$ ) input is a Schmitt-triggered, CMOS logic input.

The Gain Select (GSEL) inputs are tri-level digital inputs. They function similar to normal logic inputs at low ( $G = +10$ ) and high voltages ( $G = +50$ ). The pin can also be set to mid-supply ( $G = +1$ ) by a low impedance source, or by leaving this pin open.

## 4.0 APPLICATIONS INFORMATION

The MCP6G01/1R/1U/2/3/4 family of Selectable Gain Amplifiers (SGA) is based on simple analog building blocks (see Figure 4-1). Each of these blocks will be explained in more detail in the following subsections.

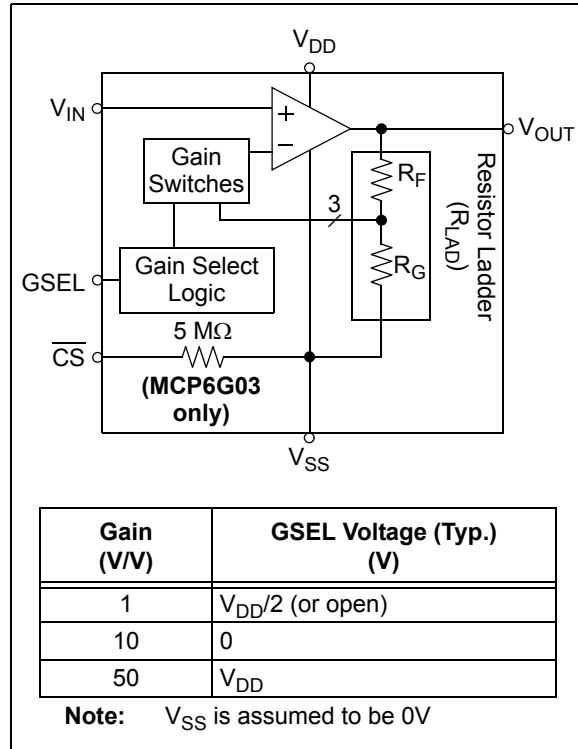

FIGURE 4-1: SGA Block Diagram.

### 4.1 Internal Op Amp

The internal op amp gives the right combination of bandwidth, accuracy, and flexibility.

#### 4.1.1 COMPENSATION CAPACITORS

The internal op amp has three compensation capacitors (comp. caps.) connected to a switching network. They are selected to give good small signal bandwidth at high gains, and good slew rate (full power bandwidth) at low gains. The change in bandwidth as gain changes is between 250 and 900 kHz. Refer to Table 4-1 for more information.

TABLE 4-1: GAIN VS. INTERNAL COMPENSATION CAPACITOR

Gain (V/V)	Internal Comp. Cap.	G x BW (MHz) Typ.	SR (V/μs) Typ.	FPBW (kHz) Typ.	BW (kHz) Typ.
1	Large	0.90	0.50	29	900
10	Medium	3.5	2.3	133	350
50	Small	12.5	4.5	260	250

- Note**
- 1: Changing the compensation capacitor does not change the DC performance (e.g.,  $V_{OS}$ ).
  - 2: G x BW is approximately the Gain Bandwidth Product of the internal op amp.
  - 3: FPBW is the Full Power Bandwidth at  $V_{DD} = 5.5V$ , which is based on slew rate (SR).
  - 4: BW is the closed-loop, small signal -3 dB bandwidth.

#### 4.1.2 RAIL-TO-RAIL INPUTS

The input stage of the internal op amp uses two differential input stages in parallel; one operates at low  $V_{IN}$  (input voltage), while the other operates at high  $V_{IN}$ . With this topology, the internal inputs can operate to 0.3V past either supply rail, although the output will clip the signal before that happens.

The inputs need to be kept within a smaller range to prevent output clipping. The input offset voltage also reduces the range; most designs will need the following for normal operation:

EQUATION 4-1:

$$\frac{V_{OL}}{G} + V_{OS} < V_{IN} < \frac{V_{OH}}{G} - V_{OS}$$

The transition between the two input stage occurs when  $V_{IN} \approx V_{DD} - 1.1V$  (see Figure 2-19 and Figure 2-22). For the best distortion and gain linearity, avoid this region of operation.

#### 4.1.3 PHASE REVERSAL

The MCP6G01/1R/1U/2/3/4 amplifier family is designed with CMOS input devices. It is designed to not exhibit phase inversion when the input pins exceed the supply voltages. Figure 2-7 shows an input voltage exceeding both supplies with no resulting phase inversion.

# MCP6G01/1R/1U/2/3/4

## 4.1.4 INPUT VOLTAGE AND CURRENT LIMITS

The ESD protection on the inputs can be depicted as shown in Figure 4-2. This structure was chosen to protect the input transistors, and to minimize input bias current ( $I_B$ ). The input ESD diodes clamp the inputs when they try to go more than one diode drop below  $V_{SS}$ . They also clamp any voltages that go too far above  $V_{DD}$ ; their breakdown voltage is high enough to allow normal operation, and low enough to bypass ESD events within the specified limits.

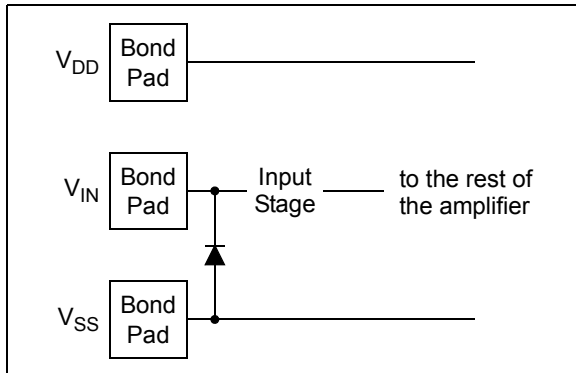

**FIGURE 4-2:** Simplified Analog Input ESD Structures.

In order to prevent damage and/or improper operation of these amplifiers, the circuits they are in must limit the currents (and voltages) at the  $V_{IN}$  pins (see Section “Absolute Maximum Ratings †” at the beginning of Section 1.0 “Electrical Characteristics”). Figure 4-3 shows the recommended approach to protecting these inputs. The internal ESD diodes prevent the input pins ( $V_{IN}$ ) from going too far below ground, and the resistor  $R_1$  limits the possible current drawn out of the input pin. Diode  $D_1$  prevents the input pin ( $V_{IN}$ ) from going too far above  $V_{DD}$ . When implemented as shown, resistor  $R_1$  also limits the current through  $D_1$ .

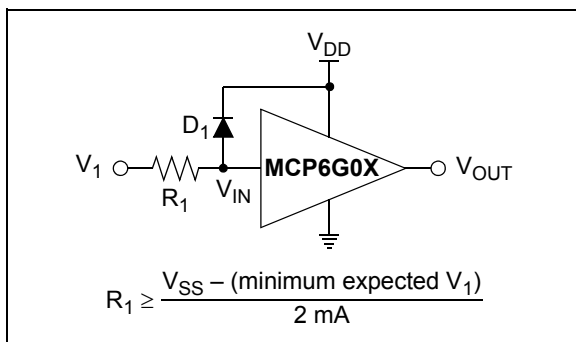

**FIGURE 4-3:** Protecting the Analog Inputs.

It is also possible to connect the diode to the left of the resistor  $R_1$ . In this case, the current through the diode  $D_1$  needs to be limited by some other mechanism. The resistor then serves as in-rush current limiter; the DC

current into the input pin ( $V_{IN}$ ) should be very small.

A significant amount of current can flow out of the inputs when the common mode voltage ( $V_{CM}$ ) is below ground ( $V_{SS}$ ); see Figure 2-17. Applications that are high impedance may need to limit the useable voltage range.

## 4.1.5 RAIL-TO-RAIL OUTPUT

The maximum output voltage swing is the maximum swing possible under a particular amplifier load current. The amplifier load current is the sum of the external load current ( $I_{OUT}$ ) and the current through the ladder resistance ( $I_{LAD}$ ); see Figure 4-4.

### EQUATION 4-2:

$$\text{Amplifier Load Current} = I_{OUT} + I_{LAD}$$

Where:

$$I_{LAD} = \frac{(V_{OUT} - V_{SS})}{R_{LAD}}$$

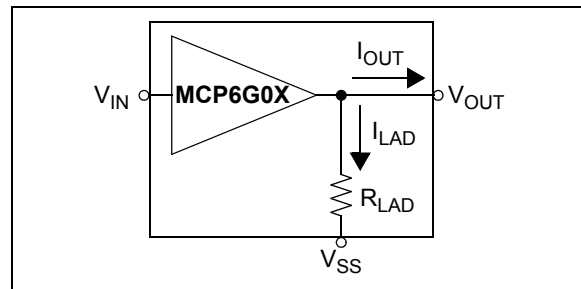

**FIGURE 4-4:** Amplifier Load Current.

See Figure 2-20 for the typical output headroom ( $V_{DD} - V_{OH}$  or  $V_{OL} - V_{SS}$ ) as a function of amplifier load current. The specification table states the output can reach within 10 mV of either supply rail when  $R_L = 100 \text{ k}\Omega$ .

## 4.2 Resistor Ladder

The resistor ladder shown in Figure 4-1 ( $R_{LAD} = R_F + R_G$ ) sets the gain. Placing the gain switches in series with the inverting input reduces the parasitic capacitance, distortion, and gain mismatch.

$R_{LAD}$  is an additional load on the output of the SGA and causes additional current draw from the supplies.

When  $\overline{CS}$  is high, the SGA is shut down (low power).  $R_{LAD}$  is still attached to the  $V_{OUT}$  and  $V_{SS}$  pins. Thus, these pins and the internal amplifier’s inverting input are all connected through  $R_{LAD}$  and the output is not high-Z (unlike the internal op amp).

$R_{LAD}$  contributes to the output noise; see Figure 2-9.

$R_{LAD}$  is intended to be driven at the  $V_{SS}$  pin by a low impedance voltage source. The power supply driving the  $V_{SS}$  pin should have an output impedance less than  $0.1\Omega$  to maintain reasonable gain accuracy.

### 4.3 MCP6G03 Chip Select ( $\overline{CS}$ )

The MCP6G03 is a single amplifier with chip select ( $\overline{CS}$ ). When  $\overline{CS}$  is high, the internal op amp is shut down and its output placed in a high-Z state. The resistive ladder is always connected between  $V_{SS}$  and  $V_{OUT}$ , even in shutdown. This means that the output resistance will be  $350\text{ k}\Omega$  (typ.), with a path for output signals to appear at the input. The supply current at  $V_{SS}$  includes the current through the load resistor and ladder resistors; it also includes current from the  $\overline{CS}$  pin to  $V_{SS}$ . When  $\overline{CS}$  is low, the amplifier is enabled. If  $\overline{CS}$  is left floating, the amplifier may not operate properly.

Figure 1-2 and Figure 2-43 show how the output voltage and supply current response to a  $\overline{CS}$  pulse.

### 4.4 Gain Select (GSEL)

The amplifier can be set to the gains +1 V/V, +10 V/V, and +50 V/V using one input pin (GSEL). At the same time, different compensation capacitors are selected to optimize the bandwidth vs. slew rate trade-off (see Table 4-1). Table 4-2 shows how to change the gain using a GPIO pin on a microcontroller and Table 4-3 shows how to hard wire the gain (i.e., using PCB wiring).

**TABLE 4-2: MCU DRIVEN GAIN SELECTION**

Gain	MCU Pin's State
+1 V/V	Output PIC's $V_{REF}$ at $V_{DD}/2$
	Digital Output High-Z (Notes 1)
	Output $V_{DD}/2$ PWM signal (Notes 2)
+10 V/V	Digital Output driven Low
+50 V/V	Digital Output driven High

**Note 1:** See Section 4.8.1 "Driving the Gain Select Pin with a Microcontroller GPIO Pin".

**2:** See Section 4.8.2 "Driving the Gain Select Pin with a PWM Signal"

**TABLE 4-3: HARD WIRED GAIN SELECTION**

Selected Gain	Possible GSEL Drivers
+1 V/V	Open Circuit (Note 1)
	Low impedance source at $V_{DD}/2$
+10 V/V	Tied to GND (0V)
+50 V/V	Tied to $V_{DD}$

**Note 1:** The GSEL pin floats to mid-supply ( $V_{DD}/2$ ); a bypass capacitor may be needed.

### 4.5 Capacitive Load and Stability

Large capacitive loads can cause stability problems and reduced bandwidth for the MCP6G01/1R/1U/2/3/4 family of SGAs (Figure 2-30 and Figure 2-34). As the load capacitance increases, there is a corresponding increase in frequency response peaking and step response overshoot and ringing. This happens because a large load capacitance decreases the internal amplifier's phase margin and bandwidth.

When driving large capacitive loads with these SGAs (i.e.,  $> 60\text{ pF}$ ), a small series resistor at the output ( $R_{ISO}$  in Figure 4-5) improves the internal amplifier's stability by making the load resistive at higher frequencies. The bandwidth will be generally lower than the bandwidth with no capacitive load.

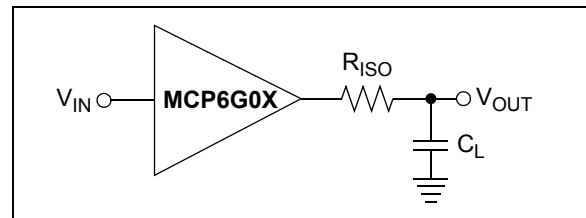

**FIGURE 4-5: SGA Circuit for Large Capacitive Loads.**

Figure 4-6 gives recommended  $R_{ISO}$  values for different capacitive loads. After selecting  $R_{ISO}$  for your circuit, double check the resulting frequency response peaking and step response overshoot on the bench. Modify  $R_{ISO}$ 's value until the response is reasonable at all gains.

# MCP6G01/1R/1U/2/3/4

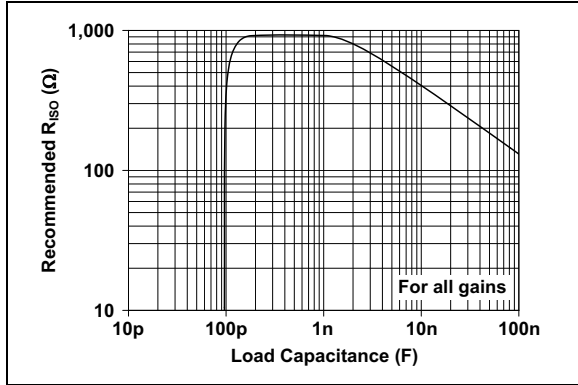

FIGURE 4-6: Recommended  $R_{ISO}$ .

## 4.6 Layout Considerations

Good PC board layout techniques will help achieve the performance shown in Section 1.0 “Electrical Characteristics” and Section 2.0 “Typical Performance Curves”. It will also help minimize Electromagnetic Compatibility (EMC) issues.

Because the MCP6G01/1R/1U/2/3/4 SGAs’ frequency response reaches unity gain at 10 MHz when  $G = 50$ , it is important to use good PCB layout techniques. Any parasitic coupling at high frequency might cause undesired peaking. Filtering high frequency signals (i.e., fast edge rates) can help.

### 4.6.1 COMPONENT PLACEMENT

Separate different circuit functions: digital from analog, low speed from high speed, and low power from high power. This will reduce crosstalk.

Keep sensitive traces short and straight. Separate them from interfering components and traces. This is especially important for high frequency (low rise time) signals.

### 4.6.2 SUPPLY BYPASS

Use a local bypass capacitor (0.01  $\mu\text{F}$  to 0.1  $\mu\text{F}$ ) within 2 mm of the  $V_{DD}$  pin for good, high frequency performance. It must connect directly to ground.

Use a bulk bypass capacitor (i.e., 1.0  $\mu\text{F}$  to 10  $\mu\text{F}$ ) within 100 mm of the  $V_{DD}$  pin. It needs to connect to ground, and provides large, slow currents. This capacitor may be shared with other nearby analog parts.

Ground plane is important, and power plane(s) can also be of great help. High frequency (e.g., multi-layer ceramic capacitors), surface mount components improve the supply’s performance.

### 4.6.3 INPUT SOURCE IMPEDANCE

The sources driving the inputs of the SGAs need to have reasonably low source impedance at higher frequencies. Figure 4-7 shows how the external source resistance ( $R_S$ ), SGA package pin capacitance ( $C_{P1}$ ), and SGA package pin-to-pin capacitance ( $C_{P2}$ ) form a positive feedback voltage divider network. Feedback may cause frequency response peaking and step response overshoot and ringing.

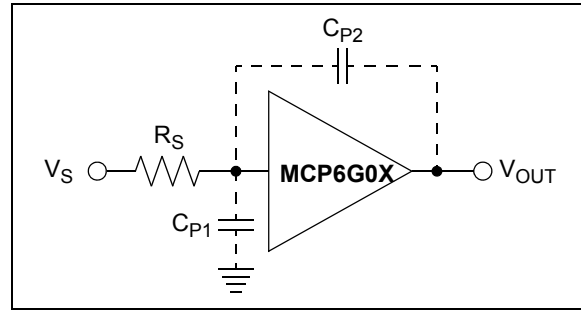

FIGURE 4-7: Positive Feedback Path.

Figure 2-10 shows the crosstalk (referred to input) that results when a hostile signal is connected to the other inputs (e.g.,  $V_{INB}$  through  $V_{IND}$ ), and the input of interest (e.g.,  $V_{INA}$ ) has  $R_S$  connected to GND. A gain of +50 was chosen for this plot because it demonstrates the worst-case behavior. Increasing  $R_S$  increases the crosstalk as expected. At a source impedance of 10  $\text{M}\Omega$ , there is noticeable change in behavior.

Most designs should use a source resistance ( $R_S$ ) no larger than 10  $\text{M}\Omega$ . Careful attention to layout parasitics and proper component selection will help minimize this effect. When a source impedance larger than 10  $\text{M}\Omega$  must be used, place a capacitor in parallel to  $C_{P1}$  to reduce the positive feedback. This capacitor needs to be large enough to overcome gain (or crosstalk) peaking, yet small enough to allow a reasonable signal bandwidth.

### 4.6.4 SIGNAL COUPLING

The input pins of the MCP6G01/1R/1U/2/3/4 family of SGAs are high impedance. This makes them especially susceptible to capacitively coupled noise. Using a ground plane helps reduce this problem.

When noise is capacitively coupled, the ground plane provides additional shunt capacitance to ground. When noise is magnetically coupled, the ground plane reduces the mutual inductance between traces. Increasing the separation between traces makes a significant difference.

Changing the direction of one of the traces can also reduce magnetic coupling. It may help to locate guard traces next to the victim trace. They should be on both sides of, and as close as possible to, the victim trace. Connect the guard traces to the ground plane at both ends. Also connect long guard traces to the ground plane in the middle.

## 4.7 Unused Amplifiers

An unused amplifier in a quad package (MCP6G04) should be configured as shown in Figure 4-8. This circuit prevents the output from toggling and causing crosstalk. Because the  $V_{IN}$  pin looks like an open circuit, the GSEL voltage is automatically set at  $V_{DD}/2$ , and the gain is 1 V/V. The output pin provides a buffered  $V_{DD}/2$  voltage and minimizes the supply current draw of the unused amplifier.

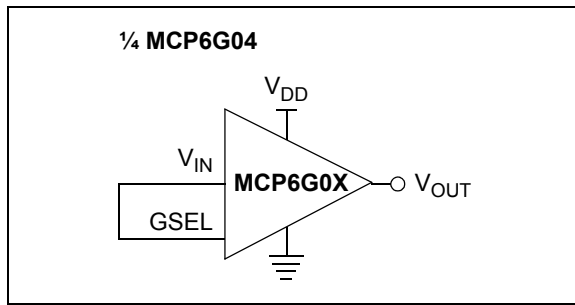

FIGURE 4-8: Unused Amplifiers.

## 4.8 Typical Applications

### 4.8.1 DRIVING THE GAIN SELECT PIN WITH A MICROCONTROLLER GPIO PIN

The circuit in Figure 4-9 uses a microcontroller GPIO pin to drive the Gain Select input (GSEL). Setting the GPIO pin to logic low, high-Z or logic high gives a GSEL voltage of 0V,  $V_{DD}/2$  or  $V_{DD}$ , respectively ( $G = 10, 1$  or 50).

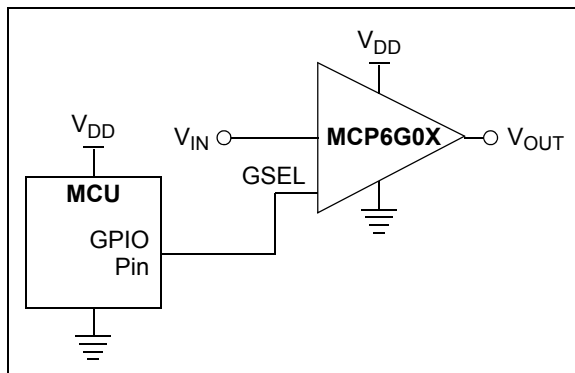

FIGURE 4-9: Driving the GSEL Pin.

The microcontroller's GPIO pin cannot produce a leakage current of more than  $\pm 1 \mu\text{A}$  for this circuit to function properly. In noisy environments, a capacitor may need to be added to the GPIO pin.

### 4.8.2 DRIVING THE GAIN SELECT PIN WITH A PWM SIGNAL

The circuit in Figure 4-10 uses a PWM output on a PIC microcontroller (100 kHz clock rate) to drive the Gain Select input (GSEL). Setting the PWM duty cycle to 0%, 50% or 100% gives a GSEL voltage of 0V,  $V_{DD}/2$  or  $V_{DD}$ , respectively ( $G = 10, 1$  or 50).

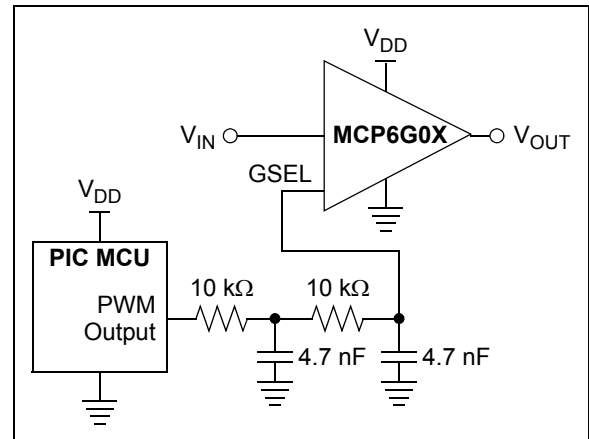

FIGURE 4-10: Driving the GSEL Pin.

The PWM clock rate needs to be fast so it is easily filtered and does not interfere with the desired signal, and it needs to be slow enough for good accuracy and low crosstalk. This filter reduces the ripple at the GSEL pin to about 7 mV<sub>P-P</sub> at  $V_{DD} = 5.0\text{V}$ . The 10% settling time is about 200  $\mu\text{s}$ ; the filter limits how quickly the gain can be changed. Scale the resistors and/or capacitors for other clock rates, or for different ripple.

### 4.8.3 GAIN RANGING

Figure 4-11 shows a circuit that measures the current  $I_x$ . The circuit's performance benefits from changing the gain on the SGA. Just as a hand-held multimeter uses different measurement ranges to obtain the best results, this circuit makes it easy to set a high gain for small signals and a low gain for large signals. As a result, the required dynamic range at the SGA's output is less than at its input (by up to 34 dB).

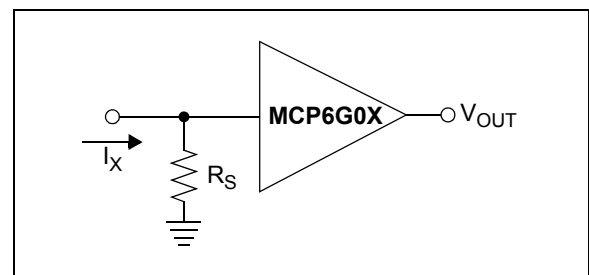
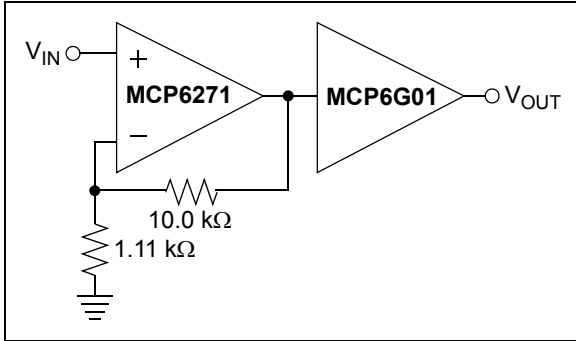

FIGURE 4-11: Wide Dynamic Range Current Measurement Circuit.

# MCP6G01/1R/1U/2/3/4

## 4.8.4 SHIFTED GAIN RANGE SGA

Figure 4-12 shows a circuit using a MCP6271 at a gain of +10 in front of a MCP6G01. This shifts the overall gain range to +10 V/V to +500 V/V (from +1 V/V to +50 V/V).



**FIGURE 4-12:** SGA with Higher Gain Range.

It is also easy to shift the gain range to lower gains (see Figure 4-13). The MCP6001 acts as a unity gain buffer, and the resistive voltage divider shifts the gain range down to +0.1 V/V to +5.0 V/V (from +1 V/V to +50 V/V).

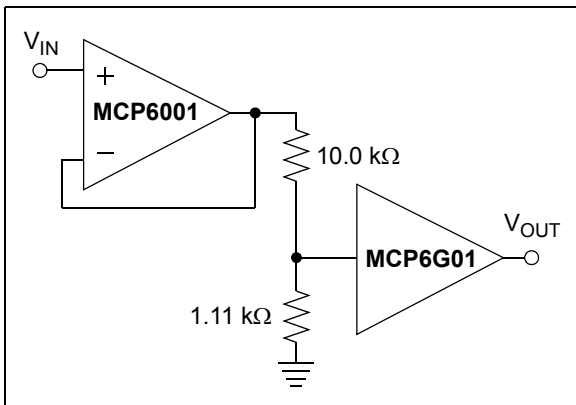

**FIGURE 4-13:** SGA with Lower Gain Range.

## 4.8.5 ADC DRIVER

This family of SGAs is well suited for driving Analog-to-Digital Converters (ADC). The gains (1, 10, and 50) effectively increase the ADC's input resolution by a factor of as large as 50 (i.e., by 5.6 bits). This works well for applications needing relative accuracy more than absolute accuracy (e.g., power monitoring); see Figure 4-14.

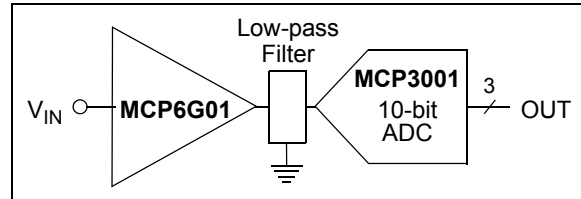

**FIGURE 4-14:** SGA as an ADC Driver.

The low-pass filter in the block diagram reduces the integrated noise at the MCP6G01's output and serves as an anti-aliasing filter. This filter may be designed using Microchip's FilterLab<sup>®</sup> software, available at [www.microchip.com](http://www.microchip.com).



## 5.0 PACKAGING INFORMATION

### 5.1 Package Marking Information

#### 5-Lead SOT-23 (MCP6G01, MCP6G01R, MCP6G01U)

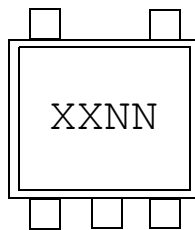

Device	Code
MCP6G01	CKNN
MCP6G01R	CLNN
MCP6G01U	CMNN

**Note:** Applies to 5-Lead SOT-23

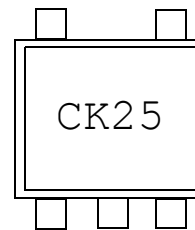

#### 8-Lead SOIC (150 mil) (MCP6G01, MCP6G02, MCP6G03)

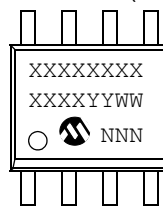

Example:

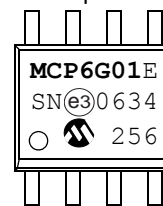

#### 8-Lead MSOP (MCP6G01, MCP6G02, MCP6G03)

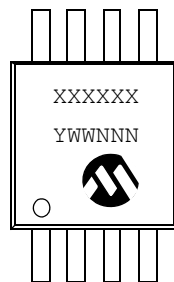

Example:

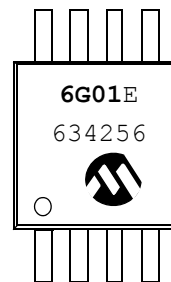

<b>Legend:</b>	XX...X	Customer-specific information
	Y	Year code (last digit of calendar year)
	YY	Year code (last 2 digits of calendar year)
	WW	Week code (week of January 1 is week '01')
	NNN	Alphanumeric traceability code
	(e3)	Pb-free JEDEC designator for Matte Tin (Sn)
	*	This package is Pb-free. The Pb-free JEDEC designator (e3) can be found on the outer packaging for this package.

**Note:** In the event the full Microchip part number cannot be marked on one line, it will be carried over to the next line, thus limiting the number of available characters for customer-specific information.

# MCP6G01/1R/1U/2/3/4

## Package Marking Information (Continued)

14-Lead SOIC (150 mil) (MCP6S24)

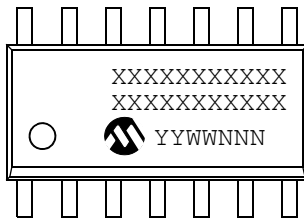

Example:

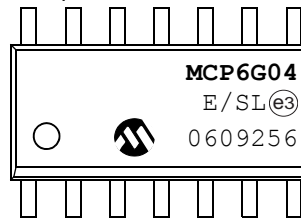

14-Lead TSSOP (4.4mm) (MCP6S24)

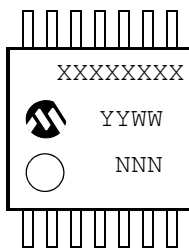

Example:

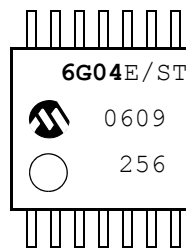

<b>Legend:</b>	XX...X	Customer-specific information
	Y	Year code (last digit of calendar year)
	YY	Year code (last 2 digits of calendar year)
	WW	Week code (week of January 1 is week '01')
	NNN	Alphanumeric traceability code
	(e3)	Pb-free JEDEC designator for Matte Tin (Sn)
	*	This package is Pb-free. The Pb-free JEDEC designator (e3) can be found on the outer packaging for this package.

**Note:** In the event the full Microchip part number cannot be marked on one line, it will be carried over to the next line, thus limiting the number of available characters for customer-specific information.

# MCP6G01/1R/1U/2/3/4

## 5-Lead Plastic Small Outline Transistor (OT) (SOT-23)

**Note:** For the most current package drawings, please see the Microchip Packaging Specification located at <http://www.microchip.com/packaging>

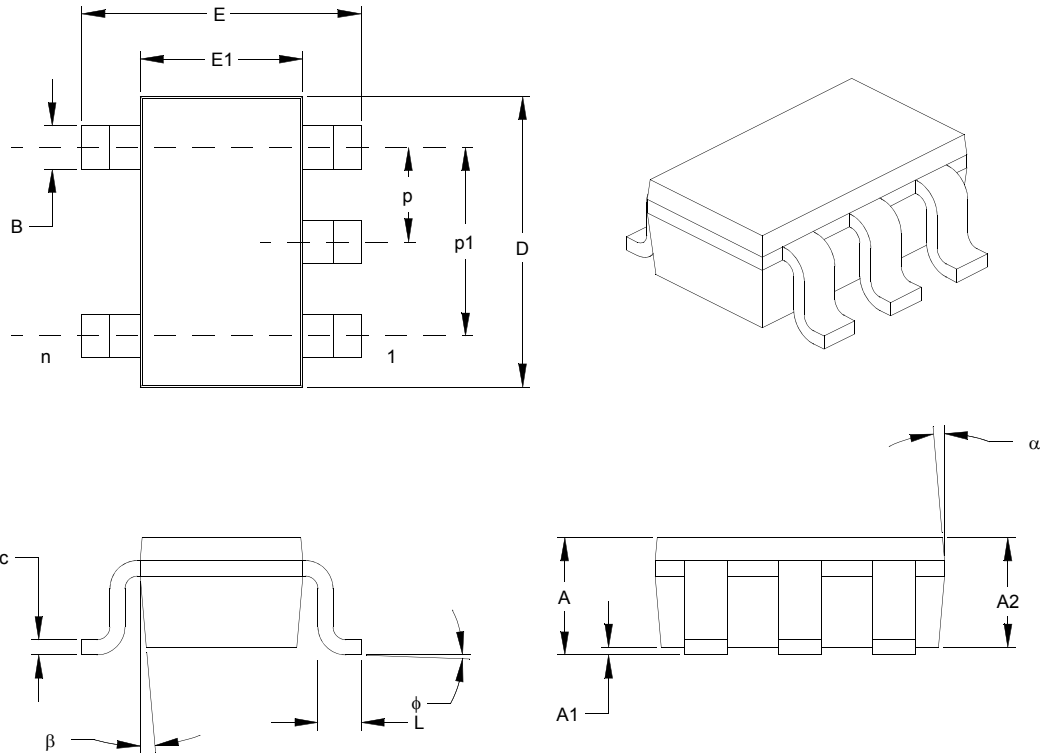

Units		INCHES*			MILLIMETERS		
Dimension Limits		MIN	NOM	MAX	MIN	NOM	MAX
Number of Pins	n		5			5	
Pitch	p		.038			0.95	
Outside lead pitch (basic)	p1		.075			1.90	
Overall Height	A	.035	.046	.057	0.90	1.18	1.45
Molded Package Thickness	A2	.035	.043	.051	0.90	1.10	1.30
Standoff	A1	.000	.003	.006	0.00	0.08	0.15
Overall Width	E	.102	.110	.118	2.60	2.80	3.00
Molded Package Width	E1	.059	.064	.069	1.50	1.63	1.75
Overall Length	D	.110	.116	.122	2.80	2.95	3.10
Foot Length	L	.014	.018	.022	0.35	0.45	0.55
Foot Angle	f	0	5	10	0	5	10
Lead Thickness	c	.004	.006	.008	0.09	0.15	0.20
Lead Width	B	.014	.017	.020	0.35	0.43	0.50
Mold Draft Angle Top	a	0	5	10	0	5	10
Mold Draft Angle Bottom	b	0	5	10	0	5	10

\* Controlling Parameter

**Notes:**

Dimensions D and E1 do not include mold flash or protrusions. Mold flash or protrusions shall not exceed .005" (0.127mm) per side.

EIAJ Equivalent: SC-74A

Drawing No. C04-091

Revised 09-12-05

# MCP6G01/1R/1U/2/3/4

## 8-Lead Plastic Micro Small Outline Package (MS) (MSOP)

**Note:** For the most current package drawings, please see the Microchip Packaging Specification located at <http://www.microchip.com/packaging>

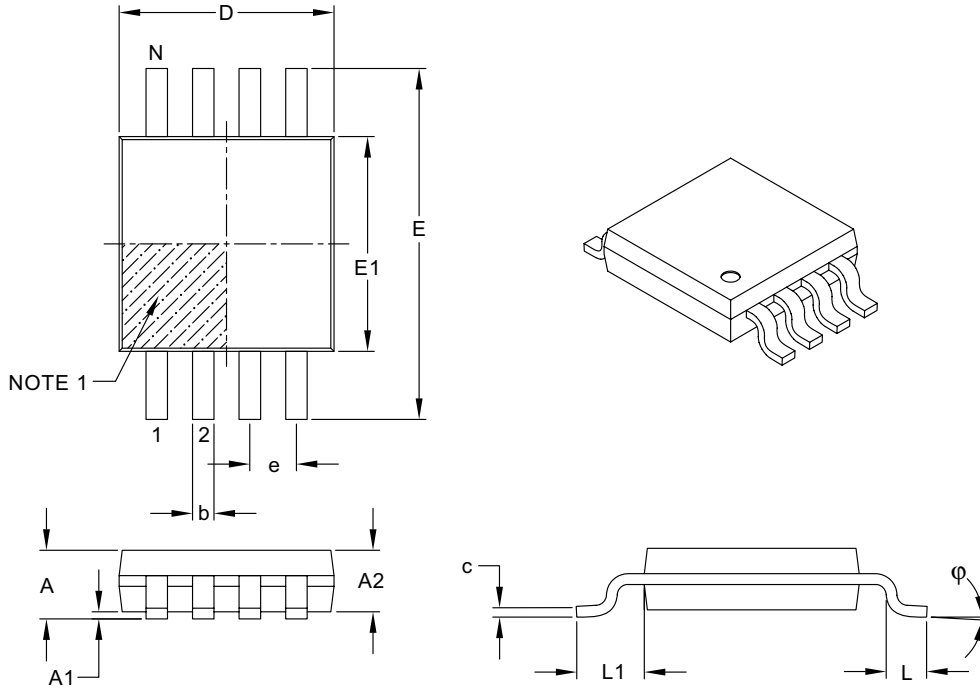

Dimension Limits	Units	MILLIMETERS		
		MIN	NOM	MAX
Number of Pins	N	8		
Pitch	e	0.65 BSC		
Overall Height	A	—	—	1.10
Molded Package Thickness	A2	0.75	0.85	0.95
Standoff	A1	0.00	—	0.15
Overall Width	E	4.90 BSC		
Molded Package Width	E1	3.00 BSC		
Overall Length	D	3.00 BSC		
Foot Length	L	0.40	0.60	0.80
Footprint	L1	0.95 REF		
Foot Angle	$\phi$	0°	—	8°
Lead Thickness	c	0.08	—	0.23
Lead Width	b	0.22	—	0.40

### Notes:

- Pin 1 visual index feature may vary, but must be located within the hatched area.
- Dimensions D and E1 do not include mold flash or protrusions. Mold flash or protrusions shall not exceed 0.15 mm per side.
- Dimensioning and tolerancing per ASME Y14.5M  
BSC: Basic Dimension. Theoretically exact value shown without tolerances.  
REF: Reference Dimension, usually without tolerance, for information purposes only.

Microchip Technology Drawing No. C04-111, Sept. 8, 2006

# MCP6G01/1R/1U/2/3/4

## 8-Lead Plastic Small Outline (SN) – Narrow, 150 mil (SOIC)

**Note:** For the most current package drawings, please see the Microchip Packaging Specification located at <http://www.microchip.com/packaging>

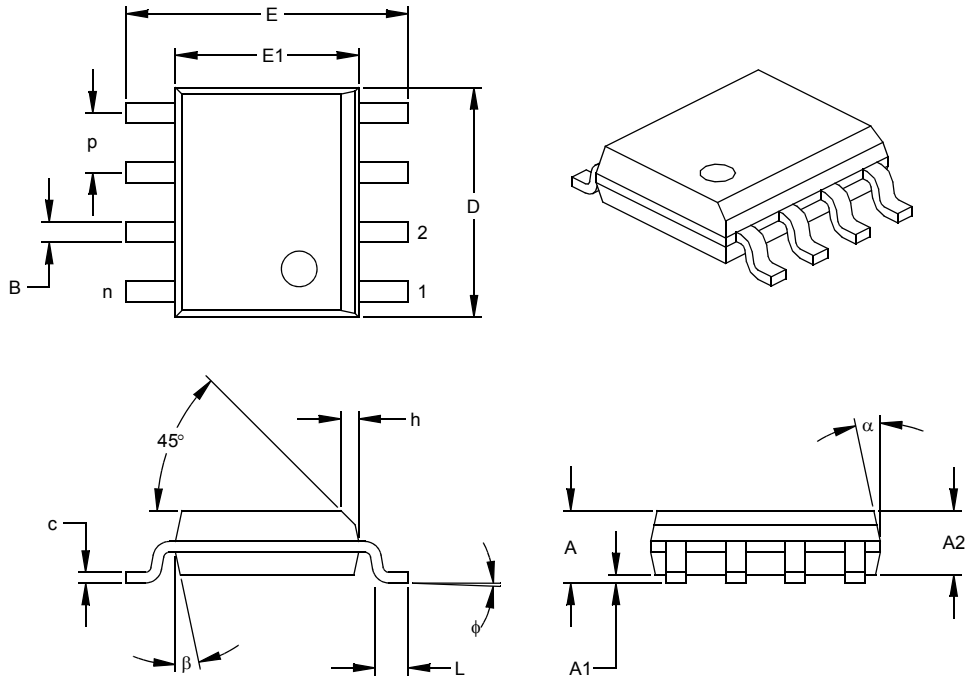

Dimension Limits	Units	INCHES*			MILLIMETERS		
		MIN	NOM	MAX	MIN	NOM	MAX
Number of Pins	n		8			8	
Pitch	p		.050			1.27	
Overall Height	A	.053	.061	.069	1.35	1.55	1.75
Molded Package Thickness	A2	.052	.056	.061	1.32	1.42	1.55
Standoff §	A1	.004	.007	.010	0.10	0.18	0.25
Overall Width	E	.228	.237	.244	5.79	6.02	6.20
Molded Package Width	E1	.146	.154	.157	3.71	3.91	3.99
Overall Length	D	.189	.193	.197	4.80	4.90	5.00
Chamfer Distance	h	.010	.015	.020	0.25	0.38	0.51
Foot Length	L	.019	.025	.030	0.48	0.62	0.76
Foot Angle	φ	0	4	8	0	4	8
Lead Thickness	c	.008	.009	.010	0.20	0.23	0.25
Lead Width	B	.013	.017	.020	0.33	0.42	0.51
Mold Draft Angle Top	α	0	12	15	0	12	15
Mold Draft Angle Bottom	β	0	12	15	0	12	15

\* Controlling Parameter

§ Significant Characteristic

**Notes:**

Dimensions D and E1 do not include mold flash or protrusions. Mold flash or protrusions shall not exceed .010" (0.254mm) per side.

JEDEC Equivalent: MS-012

Drawing No. C04-057

# MCP6G01/1R/1U/2/3/4

## 14-Lead Plastic Small Outline (SL) – Narrow, 150 mil (SOIC)

**Note:** For the most current package drawings, please see the Microchip Packaging Specification located at <http://www.microchip.com/packaging>

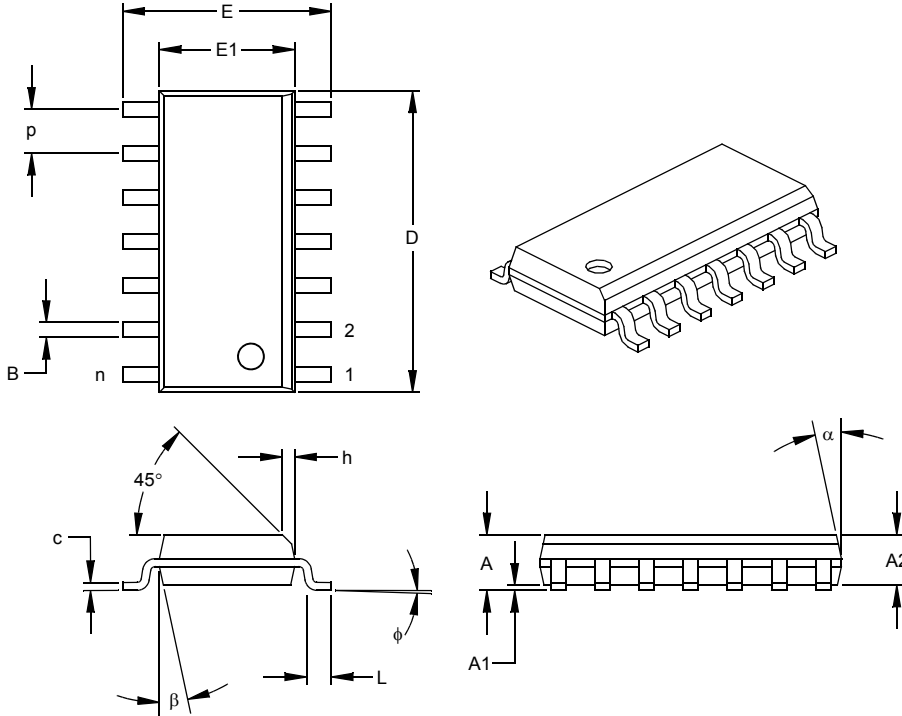

Units		INCHES*			MILLIMETERS		
Dimension Limits		MIN	NOM	MAX	MIN	NOM	MAX
Number of Pins	n	14			14		
Pitch	p	.050			1.27		
Overall Height	A	.053	.061	.069	1.35	1.55	1.75
Molded Package Thickness	A2	.052	.056	.061	1.32	1.42	1.55
Standoff §	A1	.004	.007	.010	0.10	0.18	0.25
Overall Width	E	.228	.236	.244	5.79	5.99	6.20
Molded Package Width	E1	.150	.154	.157	3.81	3.90	3.99
Overall Length	D	.337	.342	.347	8.56	8.69	8.81
Chamfer Distance	h	.010	.015	.020	0.25	0.38	0.51
Foot Length	L	.016	.033	.050	0.41	0.84	1.27
Foot Angle	φ	0	4	8	0	4	8
Lead Thickness	c	.008	.009	.010	0.20	0.23	0.25
Lead Width	B	.014	.017	.020	0.36	0.42	0.51
Mold Draft Angle Top	α	0	12	15	0	12	15
Mold Draft Angle Bottom	β	0	12	15	0	12	15

\* Controlling Parameter

§ Significant Characteristic

**Notes:**

Dimensions D and E1 do not include mold flash or protrusions. Mold flash or protrusions shall not exceed .010" (0.254mm) per side.

JEDEC Equivalent: MS-012

Drawing No. C04-065

Revised 7-20-06

# MCP6G01/1R/1U/2/3/4

## 14-Lead Plastic Thin Shrink Small Outline (ST) – 4.4 mm (TSSOP)

**Note:** For the most current package drawings, please see the Microchip Packaging Specification located at <http://www.microchip.com/packaging>

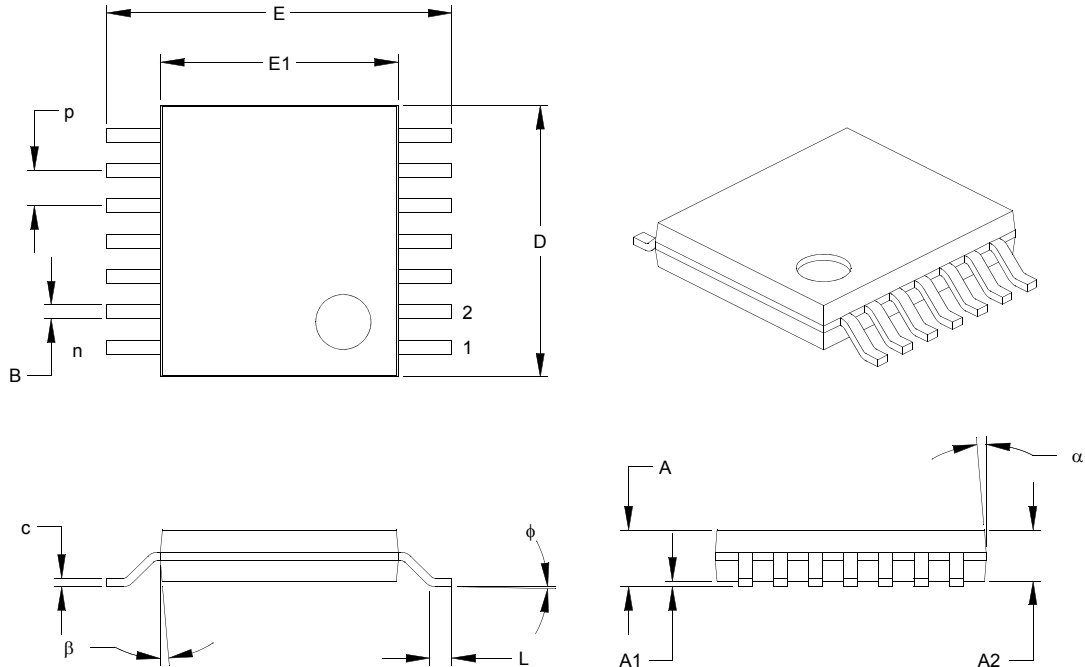

Units		INCHES			MILLIMETERS*		
Dimension Limits		MIN	NOM	MAX	MIN	NOM	MAX
Number of Pins	n	14			14		
Pitch	P	.026 BSC			0.65 BSC		
Overall Height	A	.039	.041	.043	1.00	1.05	1.10
Molded Package Thickness	A2	.033	.035	.037	0.85	0.90	0.95
Standoff	A1	.002	.004	.006	0.05	0.10	0.15
Overall Width	E	.246	.251	.256	6.25	6.38	6.50
Molded Package Width	E1	.169	.173	.177	4.30	4.40	4.50
Molded Package Length	D	.193	.197	.201	4.90	5.00	5.10
Foot Length	L	.020	.024	.028	0.50	0.60	0.70
Foot Angle	φ	0°	4°	8°	0°	4°	8°
Lead Thickness	c	.004	.006	.008	0.09	0.15	0.20
Lead Width	B	.007	.010	.012	0.19	0.25	0.30
Mold Draft Angle Top	α	12° REF			12° REF		
Mold Draft Angle Bottom	β	12° REF			12° REF		

\* Controlling Parameter

**Notes:**

Dimensions D and E1 do not include mold flash or protrusions. Mold flash or protrusions shall not exceed .005" (0.127mm) per side.

BSC: Basic Dimension. Theoretically exact value shown without tolerances.

See ASME Y14.5M

REF: Reference Dimension, usually without tolerance, for information purposes only.

See ASME Y14.5M

JEDEC Equivalent: MO-153 AB-1

Drawing No. C04-087

Revised: 08-17-05

# MCP6G01/1R/1U/2/3/4

---

NOTES:



## APPENDIX A: REVISION HISTORY

### Revision B (December 2006)

The following is the list of modifications:

- Added SOT-23-5 package option for the single gain blocks MCP6G01, MCP6G01R, and MCP6G01U.
- Added a discussion on  $V_{IN}$  range vs. G.

### Revision A (September 2006)

- Original Release of this Document.

# MCP6G01/1R/1U/2/3/4

---

NOTES:

# MCP6G01/1R/1U/2/3/4

## PRODUCT IDENTIFICATION SYSTEM

To order or obtain information, e.g., on pricing or delivery, refer to the factory or the listed sales office.

<u>PART NO.</u>	<u>=X</u>	<u>/XX</u>	
Device	Temperature Range	Package	
Device:	MCP6G01:	Single SGA	
	MCP6G01T:	Single SGA (Tape and Reel for MSOP and SOIC)	
	MCP6G01RT:	Single SGA (Tape and Reel for SOT-23-5)	
	MCP6G01UT:	Single SGA (Tape and Reel for SOT-23-5)	
	MCP6G02:	Dual SGA	
	MCP6G02T:	Dual SGA (Tape and Reel for MSOP and SOIC)	
	MCP6G03:	Single SGA	
	MCP6G03T:	Single SGA (Tape and Reel for MSOP and SOIC)	
	MCP6G04:	Quad SGA	
	MCP6G04T:	Quad SGA (Tape and Reel for SOIC and TSSOP)	
Temperature Range:	E	= -40°C to +125°C	
Package:	MS	= Plastic MSOP, 8-lead	
	OT	= Plastic Small Outline Transistor (SOT-23-5), 5-lead	
	SN	= Plastic SOIC (150 mil Body), 8-lead	
	SL	= Plastic SOIC (150 mil Body), 14-lead (MCP6G04)	
	ST	= Plastic TSSOP (4.4mm Body), 14-lead (MCP6G04)	
			<b>Examples:</b>
			a) MCP6G01-E/MS: Extended Temperature, 8LD MSOP.
			b) MCP6G01T-E/SN: Tape and Reel, Extended Temperature, 8LD SOIC.
			c) MCP6G01T-E/OT: Tape and Reel, Extended Temperature, 5LD SOT-23-5.
			d) MCP6G01RT-E/OT: Tape and Reel, Extended Temperature, 5LD SOT-23-5.
			e) MCP6G01UT-E/OT: Tape and Reel, Extended Temperature, 5LD SOT-23-5.
			a) MCP6G02-E/MS: Extended Temperature, 8LD MSOP.
			b) MCP6G02T-E/SN: Tape and Reel, Extended Temperature, 8LD SOIC.
			a) MCP6G03-E/MS: Extended Temperature, 8LD MSOP.
			b) MCP6G03T-E/SN: Tape and Reel, Extended Temperature, 8LD SOIC.
			c) MCP6G03-E/SN: Extended Temperature, 8LD SOIC.
			a) MCP6G04T-E/SL: Tape and Reel, Extended Temperature, 14LD SOIC.
			b) MCP6G04T-E/ST: Tape and Reel, Extended Temperature, 14LD TSSOP.
			c) MCP6G04-E/ST: Extended Temperature, 14LD TSSOP.

# MCP6G01/1R/1U/2/3/4

---

NOTES:

---

**Note the following details of the code protection feature on Microchip devices:**

- Microchip products meet the specification contained in their particular Microchip Data Sheet.
- Microchip believes that its family of products is one of the most secure families of its kind on the market today, when used in the intended manner and under normal conditions.
- There are dishonest and possibly illegal methods used to breach the code protection feature. All of these methods, to our knowledge, require using the Microchip products in a manner outside the operating specifications contained in Microchip's Data Sheets. Most likely, the person doing so is engaged in theft of intellectual property.
- Microchip is willing to work with the customer who is concerned about the integrity of their code.
- Neither Microchip nor any other semiconductor manufacturer can guarantee the security of their code. Code protection does not mean that we are guaranteeing the product as "unbreakable."

Code protection is constantly evolving. We at Microchip are committed to continuously improving the code protection features of our products. Attempts to break Microchip's code protection feature may be a violation of the Digital Millennium Copyright Act. If such acts allow unauthorized access to your software or other copyrighted work, you may have a right to sue for relief under that Act.

---

Information contained in this publication regarding device applications and the like is provided only for your convenience and may be superseded by updates. It is your responsibility to ensure that your application meets with your specifications. MICROCHIP MAKES NO REPRESENTATIONS OR WARRANTIES OF ANY KIND WHETHER EXPRESS OR IMPLIED, WRITTEN OR ORAL, STATUTORY OR OTHERWISE, RELATED TO THE INFORMATION, INCLUDING BUT NOT LIMITED TO ITS CONDITION, QUALITY, PERFORMANCE, MERCHANTABILITY OR FITNESS FOR PURPOSE. Microchip disclaims all liability arising from this information and its use. Use of Microchip devices in life support and/or safety applications is entirely at the buyer's risk, and the buyer agrees to defend, indemnify and hold harmless Microchip from any and all damages, claims, suits, or expenses resulting from such use. No licenses are conveyed, implicitly or otherwise, under any Microchip intellectual property rights.

**Trademarks**

The Microchip name and logo, the Microchip logo, Accuron, dsPIC, KEELOQ, microID, MPLAB, PIC, PICmicro, PICSTART, PRO MATE, PowerSmart, rfPIC, and SmartShunt are registered trademarks of Microchip Technology Incorporated in the U.S.A. and other countries.

AmpLab, FilterLab, Migratable Memory, MXDEV, MXLAB, SEEVAL, SmartSensor and The Embedded Control Solutions Company are registered trademarks of Microchip Technology Incorporated in the U.S.A.

Analog-for-the-Digital Age, Application Maestro, CodeGuard, dsPICDEM, dsPICDEM.net, dsPICworks, ECAN, ECONOMONITOR, FanSense, FlexROM, fuzzyLAB, In-Circuit Serial Programming, ICSP, ICEPIC, Linear Active Thermistor, Mindi, MiWi, MPASM, MPLIB, MPLINK, PICkit, PICDEM, PICDEM.net, PICLAB, PICtail, PowerCal, PowerInfo, PowerMate, PowerTool, REAL ICE, rFLAB, rfPICDEM, Select Mode, Smart Serial, SmartTel, Total Endurance, UNI/O, WiperLock and ZENA are trademarks of Microchip Technology Incorporated in the U.S.A. and other countries.

SQTP is a service mark of Microchip Technology Incorporated in the U.S.A.

All other trademarks mentioned herein are property of their respective companies.

© 2006, Microchip Technology Incorporated, Printed in the U.S.A., All Rights Reserved.

 Printed on recycled paper.

**QUALITY MANAGEMENT SYSTEM**  
**CERTIFIED BY DNV**  
**== ISO/TS 16949:2002 ==**

*Microchip received ISO/TS-16949:2002 certification for its worldwide headquarters, design and wafer fabrication facilities in Chandler and Tempe, Arizona, Gresham, Oregon and Mountain View, California. The Company's quality system processes and procedures are for its PIC® 8-bit MCUs, KEELOQ® code hopping devices, Serial EEPROMs, microperipherals, nonvolatile memory and analog products. In addition, Microchip's quality system for the design and manufacture of development systems is ISO 9001:2000 certified.*



**MICROCHIP**

## WORLDWIDE SALES AND SERVICE

### AMERICAS

#### Corporate Office

2355 West Chandler Blvd.  
Chandler, AZ 85224-6199  
Tel: 480-792-7200  
Fax: 480-792-7277  
Technical Support:  
<http://support.microchip.com>  
Web Address:  
[www.microchip.com](http://www.microchip.com)

#### Atlanta

Alpharetta, GA  
Tel: 770-640-0034  
Fax: 770-640-0307

#### Boston

Westborough, MA  
Tel: 774-760-0087  
Fax: 774-760-0088

#### Chicago

Itasca, IL  
Tel: 630-285-0071  
Fax: 630-285-0075

#### Dallas

Addison, TX  
Tel: 972-818-7423  
Fax: 972-818-2924

#### Detroit

Farmington Hills, MI  
Tel: 248-538-2250  
Fax: 248-538-2260

#### Kokomo

Kokomo, IN  
Tel: 765-864-8360  
Fax: 765-864-8387

#### Los Angeles

Mission Viejo, CA  
Tel: 949-462-9523  
Fax: 949-462-9608

#### Santa Clara

Santa Clara, CA  
Tel: 408-961-6444  
Fax: 408-961-6445

#### Toronto

Mississauga, Ontario,  
Canada  
Tel: 905-673-0699  
Fax: 905-673-6509

### ASIA/PACIFIC

#### Asia Pacific Office

Suites 3707-14, 37th Floor  
Tower 6, The Gateway  
Harbour City, Kowloon  
Hong Kong  
Tel: 852-2401-1200  
Fax: 852-2401-3431

#### Australia - Sydney

Tel: 61-2-9868-6733  
Fax: 61-2-9868-6755

#### China - Beijing

Tel: 86-10-8528-2100  
Fax: 86-10-8528-2104

#### China - Chengdu

Tel: 86-28-8665-5511  
Fax: 86-28-8665-7889

#### China - Fuzhou

Tel: 86-591-8750-3506  
Fax: 86-591-8750-3521

#### China - Hong Kong SAR

Tel: 852-2401-1200  
Fax: 852-2401-3431

#### China - Qingdao

Tel: 86-532-8502-7355  
Fax: 86-532-8502-7205

#### China - Shanghai

Tel: 86-21-5407-5533  
Fax: 86-21-5407-5066

#### China - Shenyang

Tel: 86-24-2334-2829  
Fax: 86-24-2334-2393

#### China - Shenzhen

Tel: 86-755-8203-2660  
Fax: 86-755-8203-1760

#### China - Shunde

Tel: 86-757-2839-5507  
Fax: 86-757-2839-5571

#### China - Wuhan

Tel: 86-27-5980-5300  
Fax: 86-27-5980-5118

#### China - Xian

Tel: 86-29-8833-7250  
Fax: 86-29-8833-7256

### ASIA/PACIFIC

#### India - Bangalore

Tel: 91-80-4182-8400  
Fax: 91-80-4182-8422

#### India - New Delhi

Tel: 91-11-4160-8631  
Fax: 91-11-4160-8632

#### India - Pune

Tel: 91-20-2566-1512  
Fax: 91-20-2566-1513

#### Japan - Yokohama

Tel: 81-45-471-6166  
Fax: 81-45-471-6122

#### Korea - Gumi

Tel: 82-54-473-4301  
Fax: 82-54-473-4302

#### Korea - Seoul

Tel: 82-2-554-7200  
Fax: 82-2-558-5932 or  
82-2-558-5934

#### Malaysia - Penang

Tel: 60-4-646-8870  
Fax: 60-4-646-5086

#### Philippines - Manila

Tel: 63-2-634-9065  
Fax: 63-2-634-9069

#### Singapore

Tel: 65-6334-8870  
Fax: 65-6334-8850

#### Taiwan - Hsin Chu

Tel: 886-3-572-9526  
Fax: 886-3-572-6459

#### Taiwan - Kaohsiung

Tel: 886-7-536-4818  
Fax: 886-7-536-4803

#### Taiwan - Taipei

Tel: 886-2-2500-6610  
Fax: 886-2-2508-0102

#### Thailand - Bangkok

Tel: 66-2-694-1351  
Fax: 66-2-694-1350

### EUROPE

#### Austria - Wels

Tel: 43-7242-2244-39  
Fax: 43-7242-2244-393

#### Denmark - Copenhagen

Tel: 45-4450-2828  
Fax: 45-4485-2829

#### France - Paris

Tel: 33-1-69-53-63-20  
Fax: 33-1-69-30-90-79

#### Germany - Munich

Tel: 49-89-627-144-0  
Fax: 49-89-627-144-44

#### Italy - Milan

Tel: 39-0331-742611  
Fax: 39-0331-466781

#### Netherlands - Drunen

Tel: 31-416-690399  
Fax: 31-416-690340

#### Spain - Madrid

Tel: 34-91-708-08-90  
Fax: 34-91-708-08-91

#### UK - Wokingham

Tel: 44-118-921-5869  
Fax: 44-118-921-5820

10/19/06