

Features

- 60V/280A,
 $R_{DS(ON)} = 2.2m\Omega(Typ.)@V_{GS}=10V$
- Reliable and Rugged
- Ultra Low On-Resistance
- 100% avalanche tested
- 175°C Operating Temperature
- Lead Free and Green Devices Available (RoHS Compliant)

Applications

- Uninterruptible Power Supplies
- Synchronous Rectification in DC/DC and AC/DC Converters

Pin Description

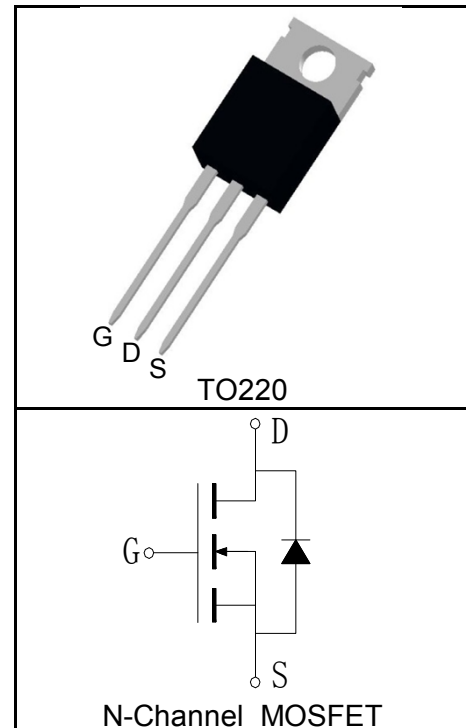

Absolute Maximum Ratings

| Symbol | Parameter | Rating | Unit |
|--|--|--------------------------------|--------------------|
| Common Ratings ($T_C=25^\circ\text{C}$ Unless Otherwise Noted) | | | |
| V_{DSS} | Drain-Source Voltage | 60 | V |
| V_{GSS} | Gate-Source Voltage | ± 25 | |
| T_J | Maximum Junction Temperature | 175 | $^\circ\text{C}$ |
| T_{STG} | Storage Temperature Range | -55 to 175 | $^\circ\text{C}$ |
| I_S | Diode Continuous Forward Current | $T_C=25^\circ\text{C}$ 280 | A |
| Mounted on Large Heat Sink | | | |
| $I_{DP}^{①}$ | 300 μs Pulse Drain Current Tested | $T_C=25^\circ\text{C}$ 1120 | A |
| $I_D^{②}$ | Continuous Drain Current($V_{GS}=10V$) | $T_C=25^\circ\text{C}$ 280 | A |
| | | $T_C=100^\circ\text{C}$ 196 | |
| P_D | Maximum Power Dissipation | $T_C=25^\circ\text{C}$ 395 | W |
| | | $T_C=100^\circ\text{C}$ 198 | |
| $R_{\theta JC}$ | Thermal Resistance-Junction to Case | 0.38 | $^\circ\text{C/W}$ |
| $R_{\theta JA}$ | Thermal Resistance-Junction to Ambient | 62.5 | $^\circ\text{C/W}$ |
| Drain-Source Avalanche Ratings | | | |
| $E_{AS}^{③}$ | Avalanche Energy, Single Pulsed | 900 | mJ |

Electrical Characteristics ($T_C=25^\circ\text{C}$ Unless Otherwise Noted)

| Symbol | Parameter | Test Condition | RU60280R | | | Unit |
|--|----------------------------------|---|----------|------|-----------|------------|
| | | | Min. | Typ. | Max. | |
| Static Characteristics | | | | | | |
| BV_{DSS} | Drain-Source Breakdown Voltage | $V_{GS}=0V, I_{DS}=250\mu A$ | 60 | | | V |
| I_{DSS} | Zero Gate Voltage Drain Current | $V_{DS}=60V, V_{GS}=0V$ | | | 1 | μA |
| | | $T_J=125^\circ\text{C}$ | | | 30 | |
| $V_{GS(th)}$ | Gate Threshold Voltage | $V_{DS}=V_{GS}, I_{DS}=250\mu A$ | 2 | | 4 | V |
| I_{GSS} | Gate Leakage Current | $V_{GS}=\pm 25V, V_{DS}=0V$ | | | ± 100 | nA |
| $R_{DS(ON)}^{(4)}$ | Drain-Source On-state Resistance | $V_{GS}=10V, I_{DS}=75A$ | | 2.2 | 3 | m Ω |
| Diode Characteristics | | | | | | |
| $V_{SD}^{(4)}$ | Diode Forward Voltage | $I_{SD}=75A, V_{GS}=0V$ | | | 1.2 | V |
| t_{rr} | Reverse Recovery Time | $I_{SD}=20A, dI_{SD}/dt=100A/\mu s$ | | 30 | | ns |
| Q_{rr} | Reverse Recovery Charge | | | 370 | | nC |
| Dynamic Characteristics⁽⁵⁾ | | | | | | |
| R_G | Gate Resistance | $V_{GS}=0V, V_{DS}=0V, F=1\text{MHz}$ | | 1.3 | | Ω |
| C_{iss} | Input Capacitance | $V_{GS}=0V,$ $V_{DS}=30V,$ Frequency=1.0MHz | | 8150 | | pF |
| C_{oss} | Output Capacitance | | | 1300 | | |
| C_{riss} | Reverse Transfer Capacitance | | | 800 | | |
| $t_{d(ON)}$ | Turn-on Delay Time | $V_{DD}=30V, I_{DS}=75A,$ $V_{GEN}=10V, R_G=2.5\Omega$ | | 35 | | ns |
| t_r | Turn-on Rise Time | | | 130 | | |
| $t_{d(OFF)}$ | Turn-off Delay Time | | | 190 | | |
| t_f | Turn-off Fall Time | | | 63 | | |
| Gate Charge Characteristics⁽⁵⁾ | | | | | | |
| Q_g | Total Gate Charge | $V_{DS}=48V, V_{GS}=10V,$ $I_{DS}=20A$ | | 245 | | nC |
| Q_{gs} | Gate-Source Charge | | | 31 | | |
| Q_{gd} | Gate-Drain Charge | | | 175 | | |

- Notes:
- ① Pulse width limited by safe operating area.
 - ② Calculated continuous current based on maximum allowable junction temperature. The package limitation current is 75A.
 - ③ Limited by $T_{Jmax}, I_{AS}=60A, V_{DD}=48V, R_G=50\Omega$, Starting $T_J=25^\circ\text{C}$.
 - ④ Pulse test; Pulse width $\leq 300\mu s$, duty cycle $\leq 2\%$.
 - ⑤ Guaranteed by design, not subject to production testing.

Ordering and Marking Information

| Device | Marking | Package | Packaging | Quantity | Reel Size | Tape width |
|---------------|----------------|----------------|------------------|-----------------|------------------|-------------------|
| RU60280R | RU60280R | TO220 | Tube | 50 | - | - |

Typical Characteristics

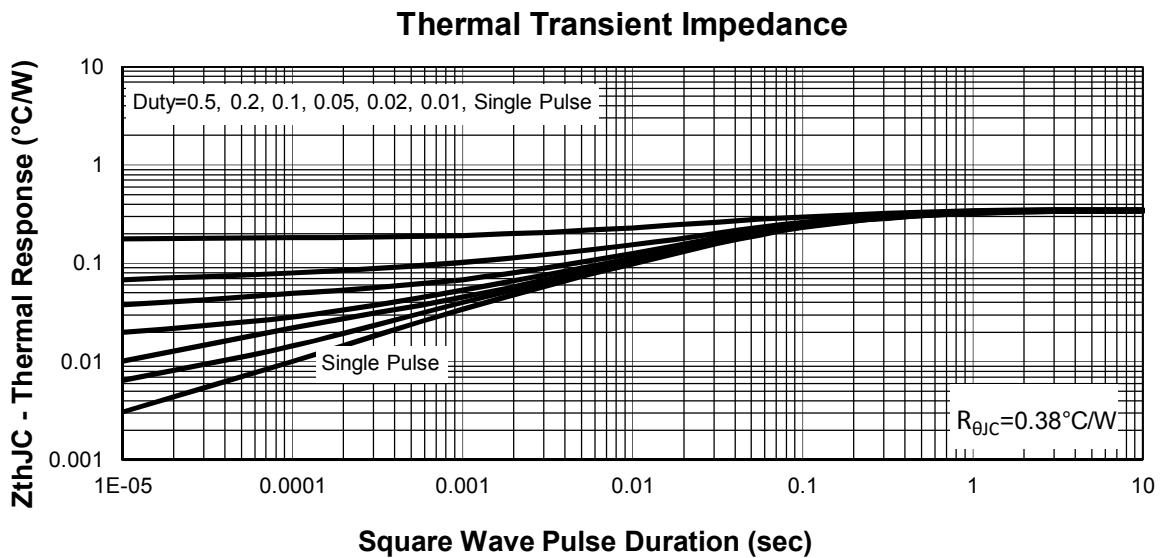
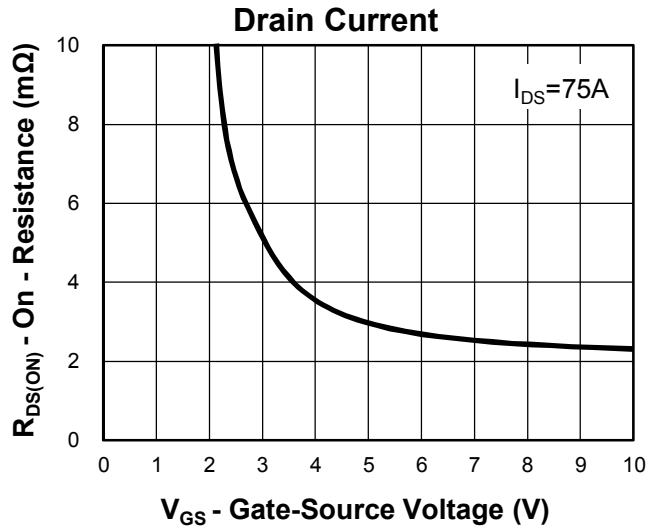
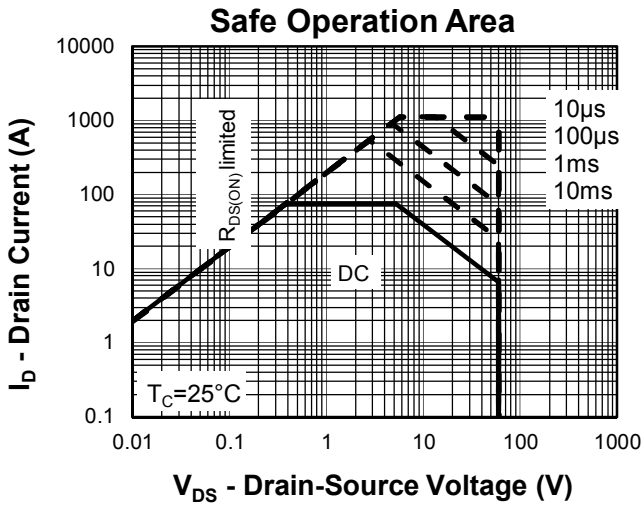
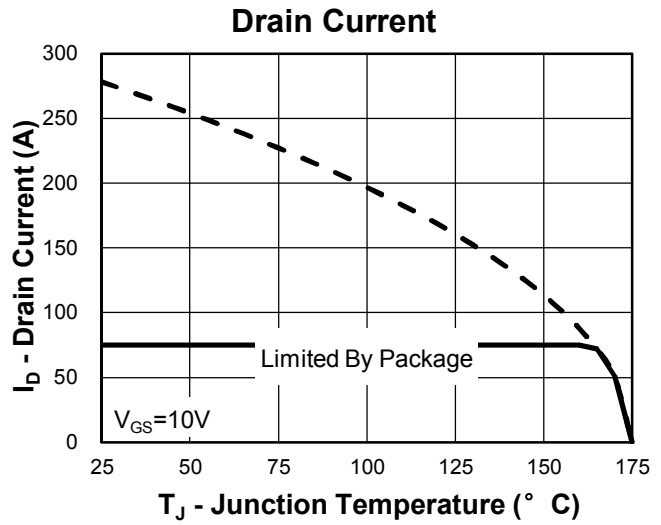
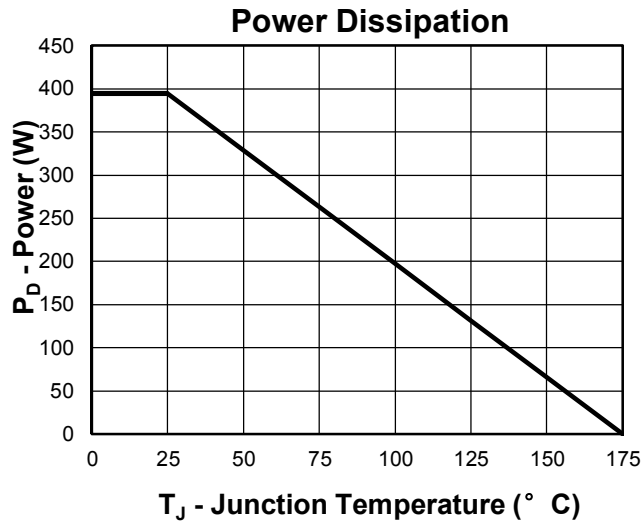

Typical Characteristics

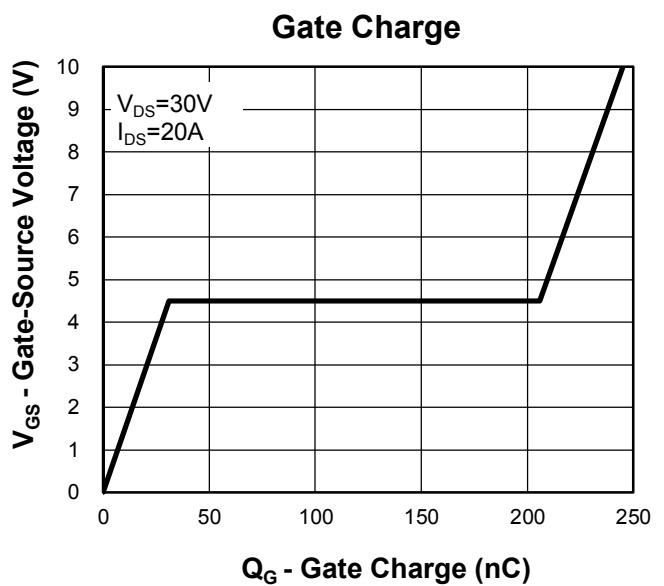
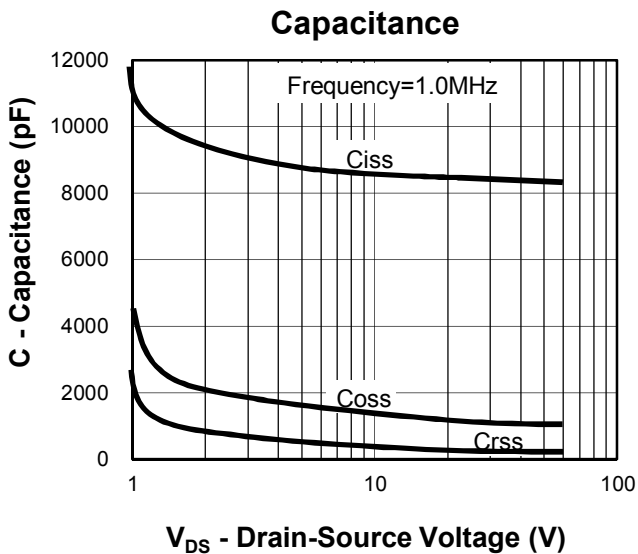
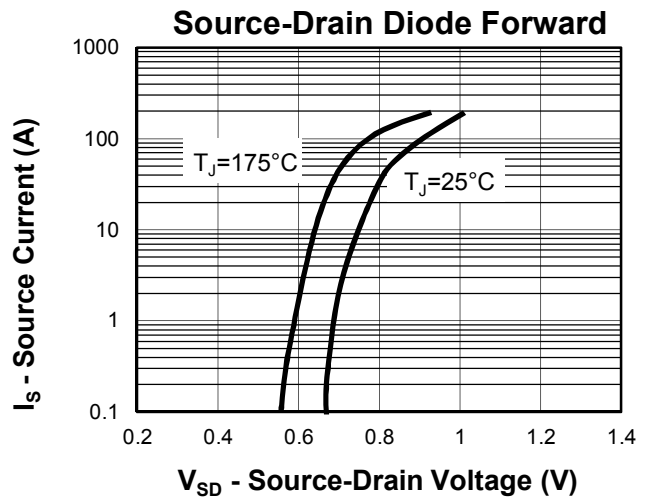
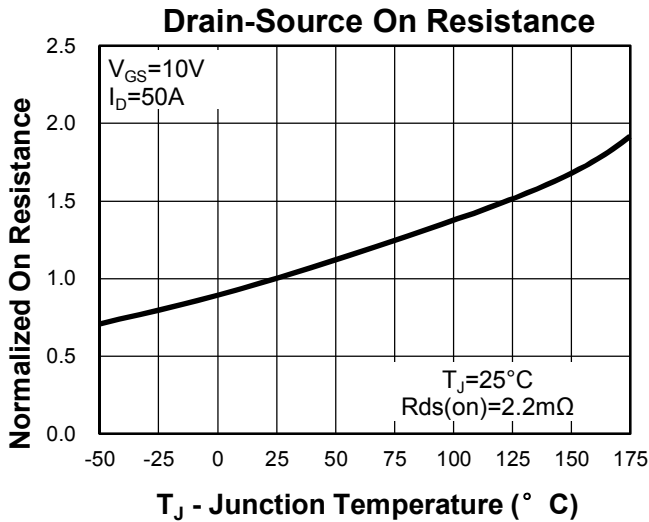
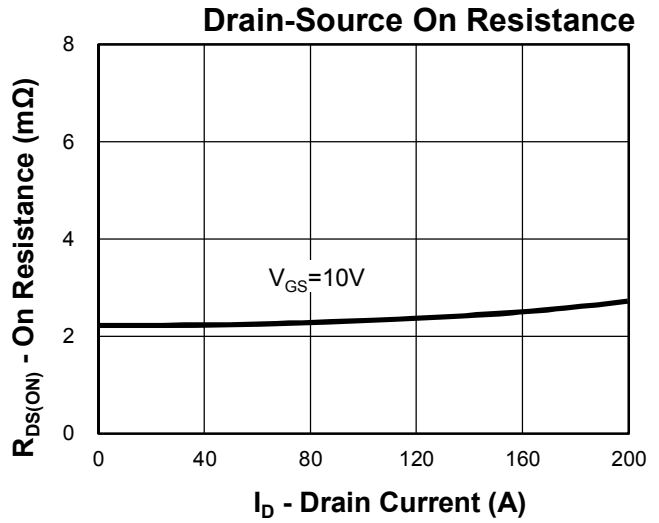
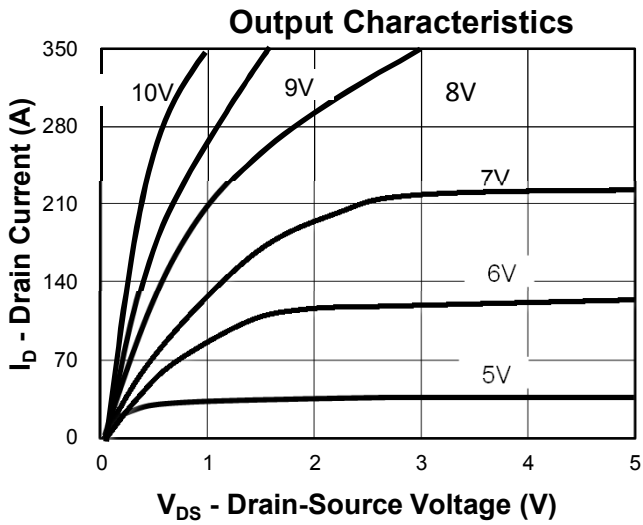

Avalanche Test Circuit and Waveforms

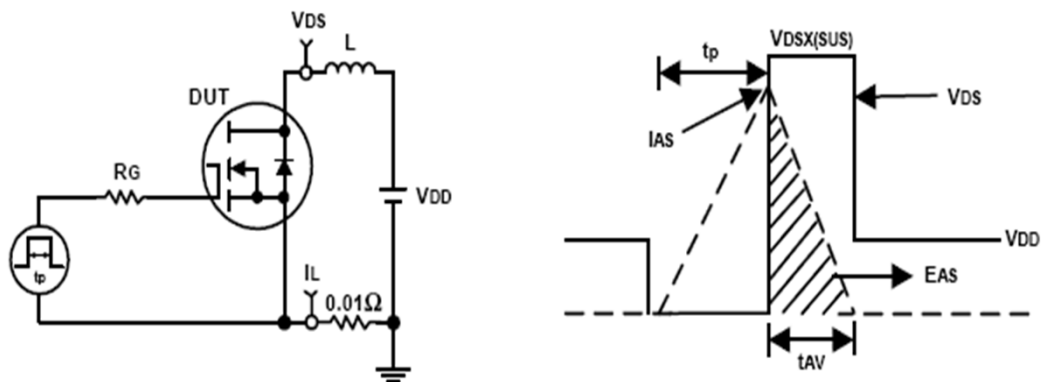

Switching Time Test Circuit and Waveforms

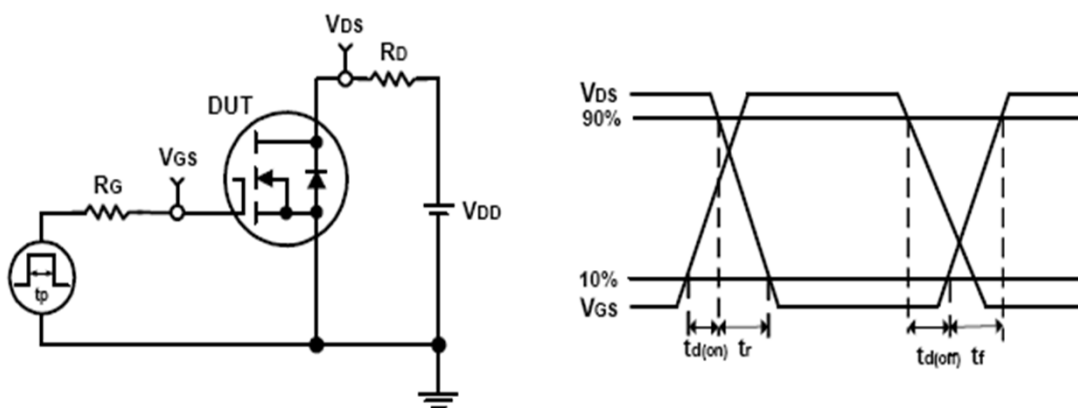

Package Information

TO220

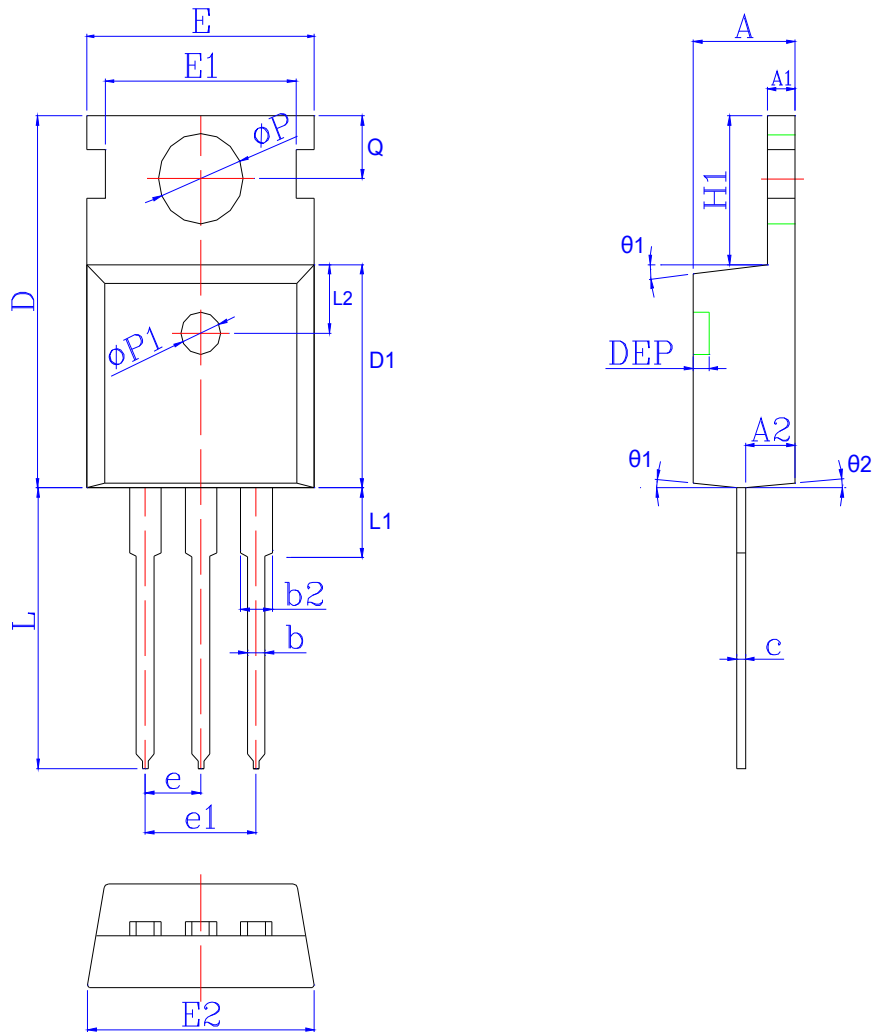

| SYMBOL | MM | | | INCH | | | SYMBOL | MM | | | INCH | | |
|--------|-------|-------|-------|-------|-------|-------|--------|----------|-------|-------|-----------|-------|-------|
| | MIN | NOM | MAX | MIN | NOM | MAX | | MIN | NOM | MAX | MIN | NOM | MAX |
| A | 4.30 | 4.54 | 4.77 | 0.169 | 0.179 | 0.188 | Φp1 | 1.40 | 1.50 | 1.60 | 0.055 | 0.059 | 0.063 |
| A1 | 1.15 | 1.30 | 1.40 | 0.045 | 0.051 | 0.055 | e | 2.54 BSC | | | 0.10 BSC | | |
| A2 | 1.90 | 2.25 | 2.60 | 0.075 | 0.089 | 0.102 | e1 | 5.08 BSC | | | 0.20 BSC | | |
| b | 0.60 | 0.80 | 1.00 | 0.024 | 0.031 | 0.039 | H1 | 6.30 | 6.50 | 6.80 | 0.248 | 0.256 | 0.268 |
| b2 | 1.17 | 1.28 | 1.72 | 0.046 | 0.050 | 0.068 | L | 12.70 | 13.18 | 13.65 | 0.500 | 0.519 | 0.537 |
| c | 0.40 | 0.50 | 0.60 | 0.016 | 0.020 | 0.024 | L1 | * | * | 3.95 | * | * | 0.156 |
| D | 15.40 | 15.70 | 16.00 | 0.606 | 0.618 | 0.630 | L2 | 2.50 REF | | | 0.098 REF | | |
| D1 | 8.96 | 9.21 | 9.46 | 0.353 | 0.363 | 0.372 | Φp | 3.50 | 3.60 | 3.75 | 0.138 | 0.142 | 0.148 |
| DEP | * | * | 0.30 | * | * | 0.012 | Q | 2.70 | 2.80 | 3.20 | 0.106 | 0.110 | 0.126 |
| E | 9.66 | 9.97 | 10.28 | 0.380 | 0.393 | 0.405 | θ 1 | 5° | 7° | 9° | 5° | 7° | 9° |
| E1 | * | 8.70 | * | * | 0.343 | * | θ 2 | 1° | 3° | 5° | 1° | 3° | 5° |
| E2 | 9.80 | 10.00 | 10.20 | 0.386 | 0.394 | 0.402 | | | | | | | |

Customer Service**Worldwide Sales and Service:**

Sales@ruichips.com

Technical Support:

Technical@ruichips.com

Investor Relations Contacts:

Investor@ruichips.com

Marcom Contact:

Marcom@ruichips.com

Editorial Contact:

Editorial@ruichips.com

HR Contact:

HR@ruichips.com

Legal Contact:

Legal@ruichips.com

Shen Zhen RUICHIPS Semiconductor CO., LTD

4th Floor, Block 8, Changyuan New Material Port, Keyuan Middle Road, Science & Industry Park,
Nanshan District, Shenzhen, CHINA

TEL: (86-755) 8311-5334

FAX: (86-755) 8311-4278

E-mail: Sales-SZ@ruichips.com