



PRODUCT SPECIFICATION

Part Number

PT482743B-TLMWD-EMR12

CUSTOMER	
CUSTOMER PART NUMBER	
DESCRIPTION	4.3" TFT LCD, Medium Brightness, RTP
APPROVED BY	
DATE	

**1. Table of Contents**

No.	Contents	Page
1	Table of Contents	2
2	Record of Revisions	3
3	Module Numbering System	4
4	Application	5
5	Features	5
6	General Specifications	5
7	Absolute Maximum Ratings	6
8	Electrical Characteristics	7
9	Block Diagram	10
10	Input / Output Terminals Pin Assignment	11
11	Interface Timing	14
12	Optical Characteristics	17
13	Reliability Test	20
14	Packaging	21
15	Precautions	22
16	Outline Drawing	24
17	Definition of Labels	25
18	Incoming Inspection Standards	27



3. Module Numbering System

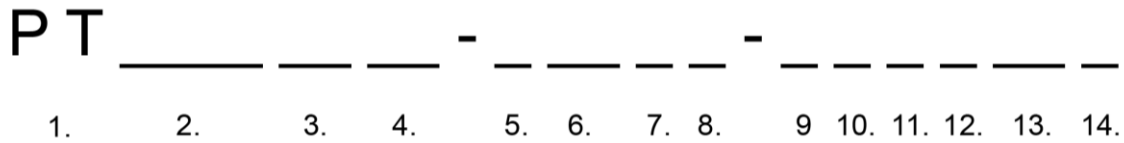

1. P-TEC TFT

8. VIEWING DIRECTION

D: 6 o'clock
U: 12 o'clock
F: Full Viewing Angle

2. LENGTH x WIDTH PIXELS

If third character is a zero, it is removed to shorten part number. Example: 240 x 320 = PT3224

9. A ~ Z CODE

Assigned by P-tec

3. DIAGONAL DIMENSIONS

Example: 3.5" display = 35 in part number

11. TEMPERATURE RANGE

Normal: Left Blank
Wide: X

4. PRODUCT VERSION

Series assigned by P-tec

12. LUMINANCE

Blank: Normal (<300 nit)
M: Middle (>= 300 nit)
H: High (> 600 nit)

5. LCD MODE

T: TN
I: IPS
V: VA

13. TOUCH PANEL OPTION

No TP: Left Blank
C: Capacitive TP
R: Resistive TP

6. POLARIZER

LM: Transmissive
LF: Transflective

14. SPECIAL CHARACTERS

Customer special requirements

7. BACKLIGHT COLOR

No Backlight: Left Blank
W: White
B: Blue/Green
S: Yellow/Green



4. Application

This specification is applied to the 4.3 inch supported TFT-LCD module With Transparent Touch Panel, and can display true 16.7M colors (8 bit/ color). The module is designed for PMP, GPS, DMB, other electronic products which require flat panel display of digital signal interface, and used as the input devices for general electric appliances via both finger and pen-entry.

5. Features

- WQVGA (480×272 pixels) resolution.
- 24 bit parallel RGB.
- Transparent Touch panel
 - 4-Wire
 - Analog Resistive

6. General Specifications

Item	Specifications	Unit
Screen Size	4.3 (Diagonal)	inch
Display Format	480RGB(H)×272(V)	dot
Active Area	95.04(H)×53.856(V)	mm
Dot Pitch	0.066(H)×0.198(V)	mm
Pixel Configuration	RGB Vertical Stripe	-
Display Mode	TN Type Transmissive Mode Normally White	-
Surface Treatment	Anti-Glare and Hard Coating(3H)	-
Viewing Direction	6 O'clock (The Gray Inversion will appear at this direction)	-
Outline Dimension	105.5(W)×67.2(H)×4.0(D)	mm
Weight	(TBD)	g
RoHS Compliance	P-tec certifies this product to be in compliance with European Union Directive 2002/95/EC on the restriction of certain hazardous substances in electrical and electronic equipment.	-



7. Absolute Maximum Ratings

7.1 Absolute Ratings of Environment

Item	Symbol	Value		Unit	Note
		Min.	Max.		
Storage Temperature	T _{ST}	-30	+80	°C	(1)(2)
Operating Ambient Temperature	T _{OP}	-20	+70	°C	(1)(2)

Note1: Background color changes slightly depending on ambient temperature.

This phenomenon is reversible.

Note2: Please refer to item of RELIABILITY.

7.2 Electrical Absolute Ratings

7.2.1 TFT-LCD Module

(Ta=25±2°C, GND=V_{SS}=0V, Note 1)

Item	Symbol	Value		Unit	Note
		Min.	Max.		
Power Supply Voltage	V _{DD}	-0.5	5.0	V	-
Input Signal Voltage	Logic input	-0.5	5.0	V	-

7.2.2 LED Driver Absolute Maximum Ratings

(Ta=25±2°C, Note 1)

Item	Symbol	Value		Unit	Note
		Min.	Max.		
LED Reverse Voltage	VR	-	1.2	V	Each LED (2)
LED Forward Current	IF	-	25	mA	Each LED

Note 1: The absolute maximum rating values of this product are not allowed to be exceeded at any times. A module should be used with any of the absolute maximum ratings exceeded, the characteristics of the module may not be recovered, or in an extreme condition, the module may be permanently destroyed.

Note 2: VR Conditions: Zener Diode 20mA



8. Electrical Characteristics

8.1 TFT-LCD Module

(Ta=25±2°C)

Item	Symbol	Value			Unit	Note
		Min.	Typ.	Max.		
Power Supply Voltage	V _{DD}	3.1	3.3	3.5	V	-
Digital Power Supply Current	I _{VDD}	-	17	25	mA	(1)
Input High Threshold Voltage	V _{IH}	0.8 V _{DD}	-	V _{DD}	V	-
Input Low Threshold Voltage	V _{IL}	0	-	0.2 V _{DD}	V	-
VSYNC Frequency	F _V	-	60	-	Hz	-
DCLK Frequency	DCLK	7.0	9.0	12	MHz	-

Note (1) The specified power consumption is under the conditions at V_{DD}=3.3V, F_V=60Hz, whereas a power dissipation check pattern below is displayed.

Black Pattern / 0 Gray

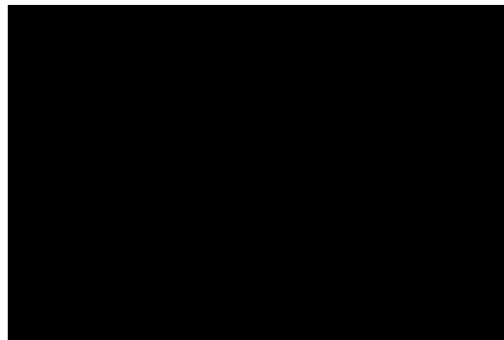

Active Area

8.2 Backlight Unit

(Ta=25±2°C)

Item	Symbol	Value			Unit	Note
		Min.	Typ.	Max.		
Current of Backlight Unit	I _L	18	20	22	mA	-
Voltage of Backlight Unit	V _L	25.2	27.9	31.5	V	(2)
Power Consumption	P _L	-	(0.558)	-	W	-
LED Life Time(25°C)	-	20000	-	-	hr	(1)

Note 1: The “LED life time” is defined as the module brightness decrease to 50% original brightness that the ambient temperature is 25°C and I_L =20mA. The LED lifetime could be decreased if operating I_L is larger than 20 mA.

Note 2: The LED Supply Voltage is defined by the number of LED at Ta=25°C and I_L =20mA.



8.3 Transparent Touch panel

Item		Value			Unit	Note
		Min.	Typ.	Max.		
Operating Voltage		-	5	10	V	-
Terminal Resistance	X-direction	500	-	1300	Ω	At connector
	Y-direction	100	-	540	Ω	At connector
Insulation Resistance		$\geq 20M\Omega$				at DC25V
Chatting		≤ 10 ms				At connector
Linearity		$\leq 1.5\%$				(1)

Note(1): Measurement condition of Linearity

Linearity Definition

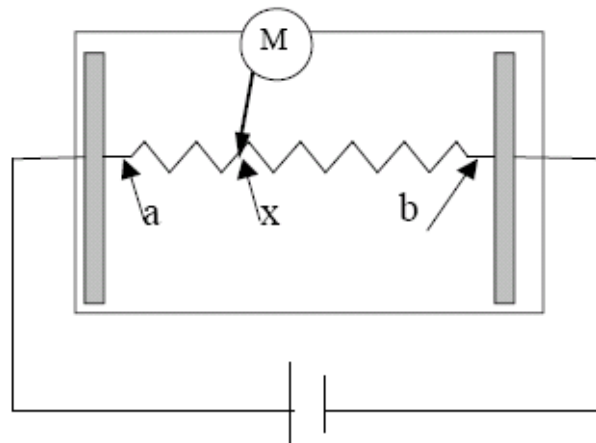



Va : maximum voltage in the active area of touch panel

Vb: minimum voltage in the active area of touch panel

X : random measuring point

Vxm: Actual voltage of Lx point

Vxi : Theoretical voltage of Lx point

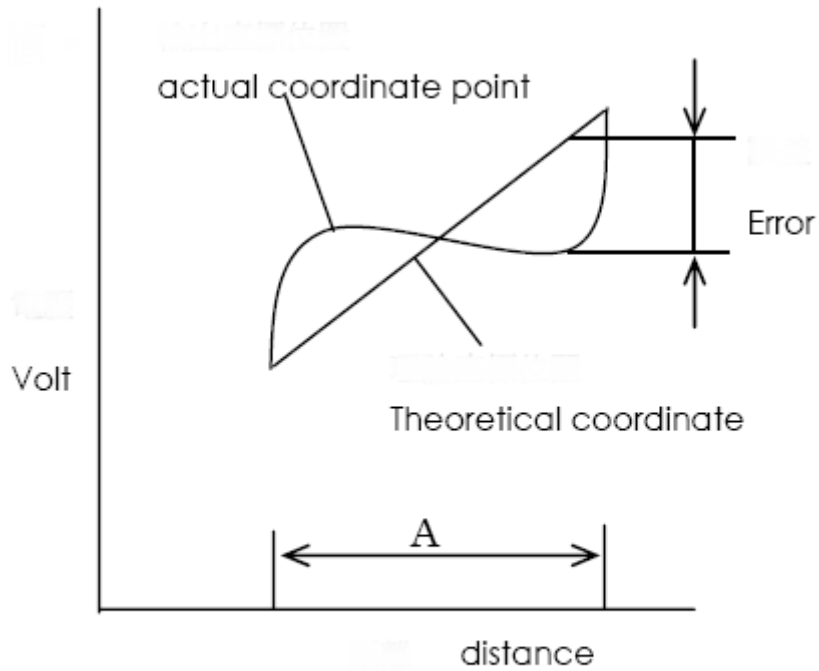

A: $\frac{1}{2} \times \text{distance}$

Linearity : $[\frac{1}{2}Vxi-Vxm\frac{1}{2}/ (Va-Vb)]*100\%$



9. Block Diagram

9.1 TFT-LCD Module with Backlight Unit

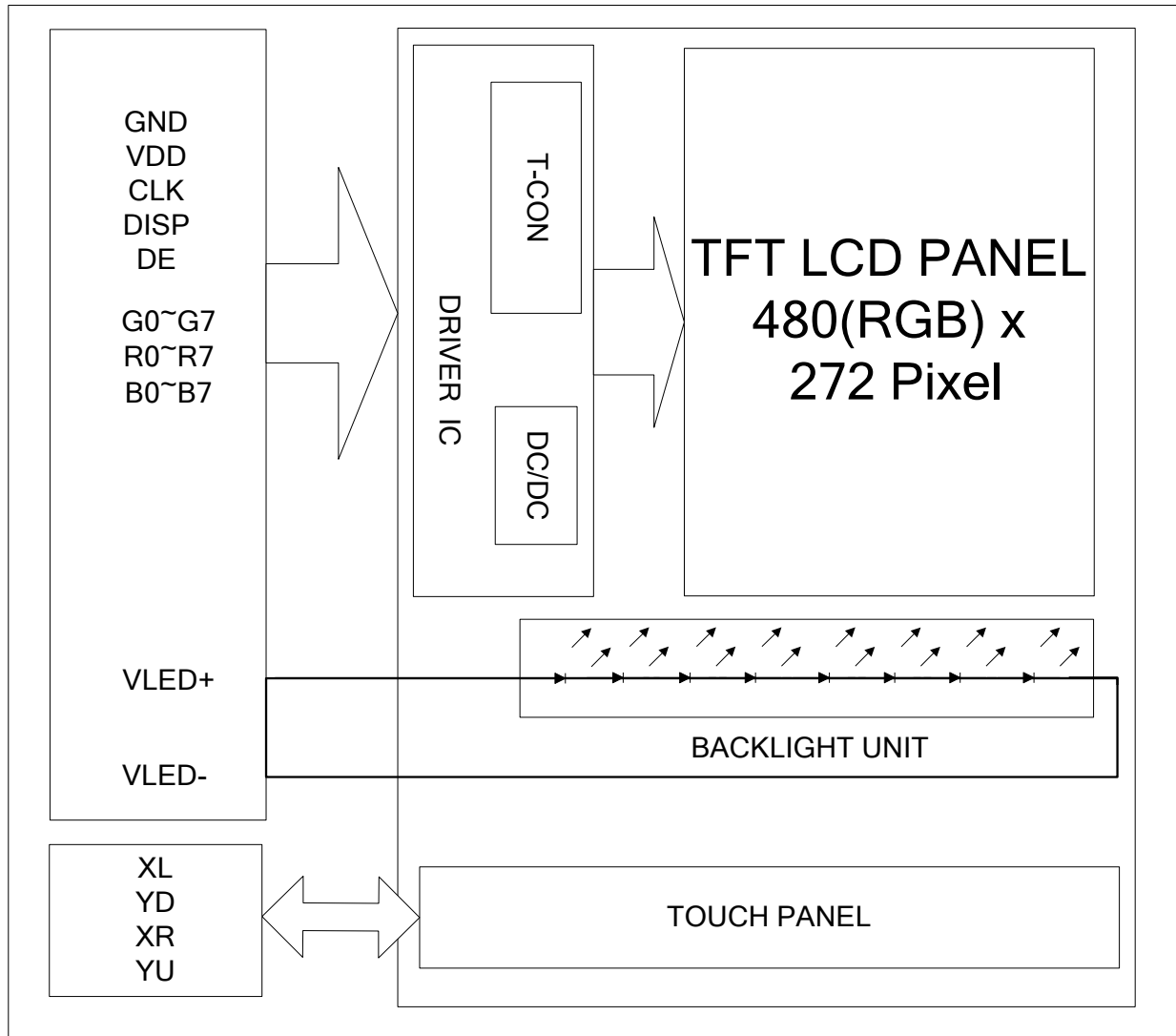



10. Input / Output Terminals Pin Assignment

10.1 TFT-LCD Module

FPC Connector is used for the module electronics interface. The recommended model is "FH19SC-40S-0.5SH" manufactured by HIROSE.

Pin No.	Symbol	I/O	Function	Remark
1	V _{LED-}	P	Power for LED backlight cathode	
2	V _{LED+}	P	Power for LED backlight anode	
3	GND	P	Power ground	
4	V _{DD}	P	Power voltage	
5	R0	I	Red data (LSB)	
6	R1	I	Red data	
7	R2	I	Red data	
8	R3	I	Red data	
9	R4	I	Red data	
10	R5	I	Red data	
11	R6	I	Red data	
12	R7	I	Red data (MSB)	
13	G0	I	Green data (LSB)	
14	G1	I	Green data	
15	G2	I	Green data	
16	G3	I	Green data	
17	G4	I	Green data	
18	G5	I	Green data	
19	G6	I	Green data	
20	G7	I	Green data (MSB)	



21	B0	I	Blue data (LSB)	
22	B1	I	Blue data	
23	B2	I	Blue data	
24	B3	I	Blue data	
25	B4	I	Blue data	
26	B5	I	Blue data	
27	B6	I	Blue data	
28	B7	I	Blue data (MSB)	
29	GND	P	Power ground	
30	CLK	I	Pixel clock	
31	DISP	I	Display on/off	
32	NC	-	No connection	
33	NC	-	No connection	
34	DE	I	Data Enable	
35	NC	-	No connection	
36	GND	P	Power ground	
37	NC	-	No connection	
38	NC	-	No connection	
39	NC	-	No connection	
40	NC	-	No connection	

I: input, O: output, P: Power



10.2 Touch panel

(Reference Connector: FCI (59453-041110) ,(59453-042110))

No.	Symbol	Functions
1	XL	X-axis left terminal
2	YD	Y-axis lower terminal
3	XR	X-axis right terminal
4	YU	Y-axis upper terminal

10.3 Color Data Input Assignment

The brightness of each primary color(red, green and blue) is based on the 8 bit gray scale data input for the color. The higher the binary input, the brighter the color. The table provides the assignment of color versus data input.

Color	Data Signal																							
	Red								Green								Blue							
	R7	R6	R5	R4	R3	R2	R1	R0	G7	G6	G5	G4	G3	G2	G1	G0	B7	B6	B5	B4	B3	B2	B1	B0
Basic Colors	Black	0	0	0	0	0	0	0	0	0	0	0	0	0	0	0	0	0	0	0	0	0	0	0
	Red	1	1	1	1	1	1	1	1	0	0	0	0	0	0	0	0	0	0	0	0	0	0	0
	Green	0	0	0	0	0	0	0	0	1	1	1	1	1	1	1	0	0	0	0	0	0	0	0
	Blue	0	0	0	0	0	0	0	0	0	0	0	0	0	0	0	1	1	1	1	1	1	1	1
	Cyan	0	0	0	0	0	0	0	0	1	1	1	1	1	1	1	1	1	1	1	1	1	1	1
	Magenta	1	1	1	1	1	1	1	1	0	0	0	0	0	0	0	1	1	1	1	1	1	1	1
	Yellow	1	1	1	1	1	1	1	1	1	1	1	1	1	1	1	0	0	0	0	0	0	0	0
	White	1	1	1	1	1	1	1	1	1	1	1	1	1	1	1	1	1	1	1	1	1	1	1
Gray Scale Of RED	Red(0) / Dark	0	0	0	0	0	0	0	0	0	0	0	0	0	0	0	0	0	0	0	0	0	0	
	Red(1)	0	0	0	0	0	0	0	1	0	0	0	0	0	0	0	0	0	0	0	0	0	0	
	Red(2)	0	0	0	0	0	0	1	0	0	0	0	0	0	0	0	0	0	0	0	0	0	0	
	:	:	:	:	:	:	:	:	:	:	:	:	:	:	:	:	:	:	:	:	:	:	:	
	:	:	:	:	:	:	:	:	:	:	:	:	:	:	:	:	:	:	:	:	:	:	:	
	Red(253)	1	1	1	1	1	1	0	1	0	0	0	0	0	0	0	0	0	0	0	0	0	0	
	Red(254)	1	1	1	1	1	1	1	0	0	0	0	0	0	0	0	0	0	0	0	0	0	0	
Red(255)	1	1	1	1	1	1	1	1	0	0	0	0	0	0	0	0	0	0	0	0	0	0		
Gray Scale Of Green	Green(0) / Dark	0	0	0	0	0	0	0	0	0	0	0	0	0	0	0	0	0	0	0	0	0	0	
	Green(1)	0	0	0	0	0	0	0	0	0	0	0	0	0	0	1	0	0	0	0	0	0	0	
	Green(2)	0	0	0	0	0	0	0	0	0	0	0	0	0	0	1	0	0	0	0	0	0	0	
	:	:	:	:	:	:	:	:	:	:	:	:	:	:	:	:	:	:	:	:	:	:	:	
	:	:	:	:	:	:	:	:	:	:	:	:	:	:	:	:	:	:	:	:	:	:	:	
	Green(253)	0	0	0	0	0	0	0	0	1	1	1	1	1	1	0	1	0	0	0	0	0	0	
	Green(254)	0	0	0	0	0	0	0	0	1	1	1	1	1	1	1	0	0	0	0	0	0	0	
Green(255)	0	0	0	0	0	0	0	0	1	1	1	1	1	1	1	1	0	0	0	0	0	0		
Gray Scale Of Blue	Blue(0) / Dark	0	0	0	0	0	0	0	0	0	0	0	0	0	0	0	0	0	0	0	0	0	0	
	Blue(1)	0	0	0	0	0	0	0	0	0	0	0	0	0	0	0	0	0	0	0	0	0	1	
	Blue(2)	0	0	0	0	0	0	0	0	0	0	0	0	0	0	0	0	0	0	0	0	0	1	
	:	:	:	:	:	:	:	:	:	:	:	:	:	:	:	:	:	:	:	:	:	:	:	
	:	:	:	:	:	:	:	:	:	:	:	:	:	:	:	:	:	:	:	:	:	:	:	
	Blue(253)	0	0	0	0	0	0	0	0	0	0	0	0	0	0	0	1	1	1	1	1	1	0	
	Blue(254)	0	0	0	0	0	0	0	0	0	0	0	0	0	0	0	1	1	1	1	1	1	1	
Blue(255)	0	0	0	0	0	0	0	0	0	0	0	0	0	0	0	1	1	1	1	1	1	1		

**11. Interface Timing****11.1 Input Signal Characteristics**

Parallel DE mode RGB input timing table

Parameter	Symbol	Value			Unit
		Min.	Typ.	Max.	
CLK frequency	fclk	7	9	12	MHz
DEV period time	Tv	277	288	400	H
DEV display area	Tvd	272			H
DEV blanking	Tvb	5	16	128	H
DEH period time	Th	520	525	800	CLK
DEH display area	Thd	480			CLK
DEH blanking	Thb	40	45	320	CLK
CLK cycle time	Tclk	83	110	143	ns
Clock width of high level	Tcwh	40	50	60	%
Clock width of low level	Tcwl	40	50	60	%
Clock rising time	t _{rck}		-	9	ns
Clock falling time	t _{fcck}		-	9	ns
Data Setup Time	t _{desu}	10	-	-	ns
Data Hold Time	t _{dahd}	10	-	-	ns
DE Setup Time	t _{desu}	10	-	-	ns
DE Hold Time	t _{dehd}	10	-	-	ns



11.2 Power Sequence

To prevent a latch-up or DC operation of the LCD module, the power on/off sequence should be as the diagram below.

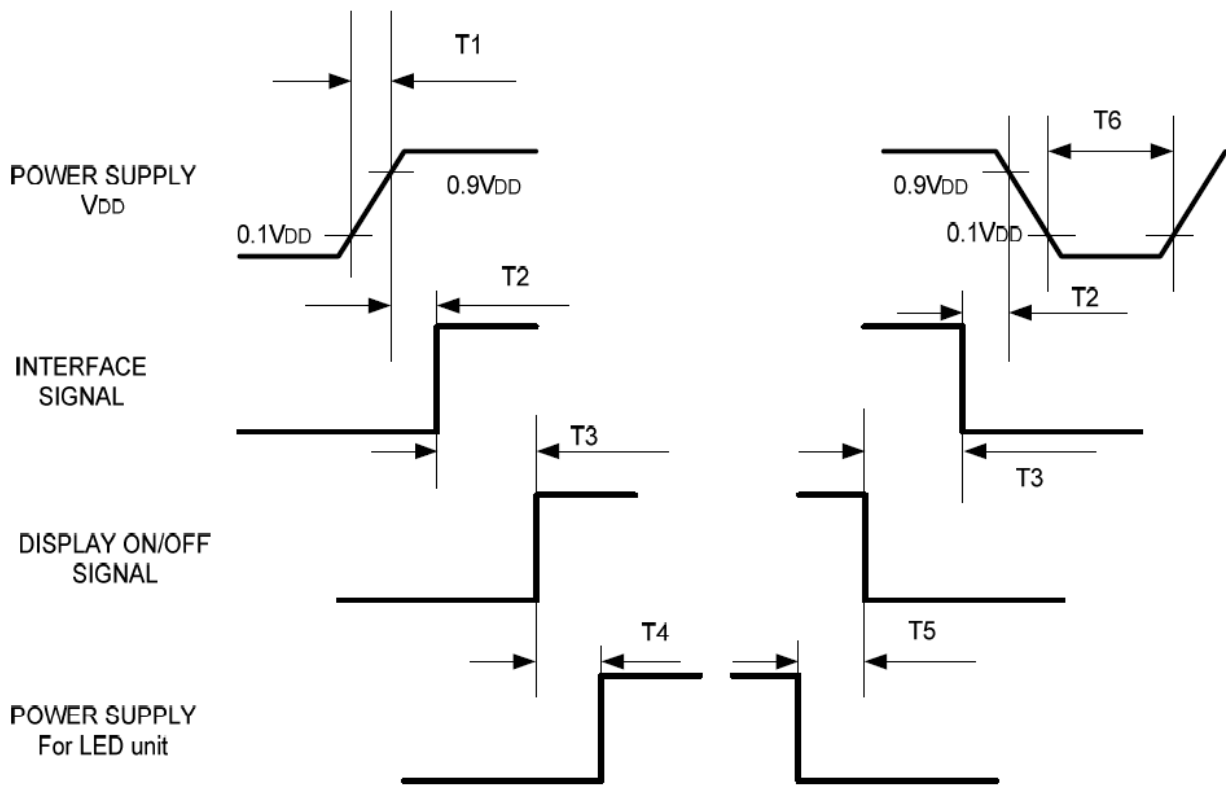

Symbol	Specification	Symbol	Specification
T1	$0 \leq T1 \leq 10 \text{ msec}$	T4	$160 \text{ msec} \leq T4$
T2	$0 \leq T2 \leq 100 \text{ msec}$	T5	$160 \text{ msec} \leq T5$
T3	$0 \leq T3 \leq 200 \text{ msec}$	T6	$1 \text{ msec} \leq T6$



11.3 Waveform

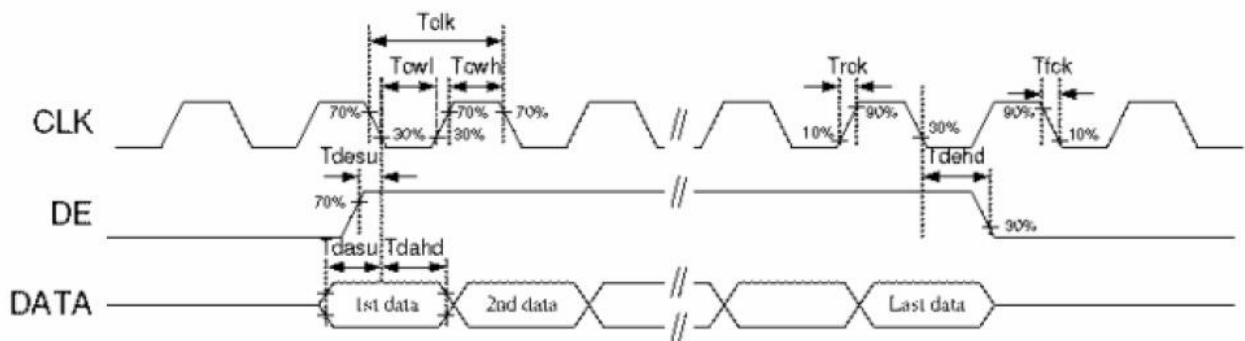
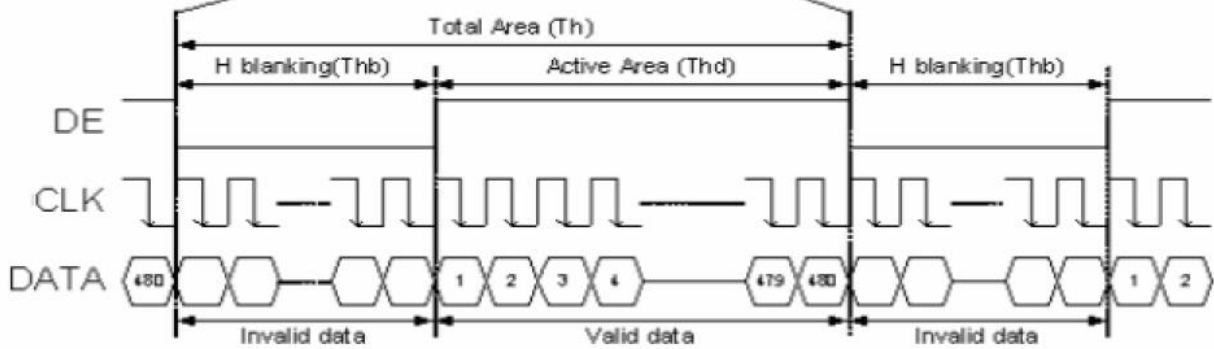
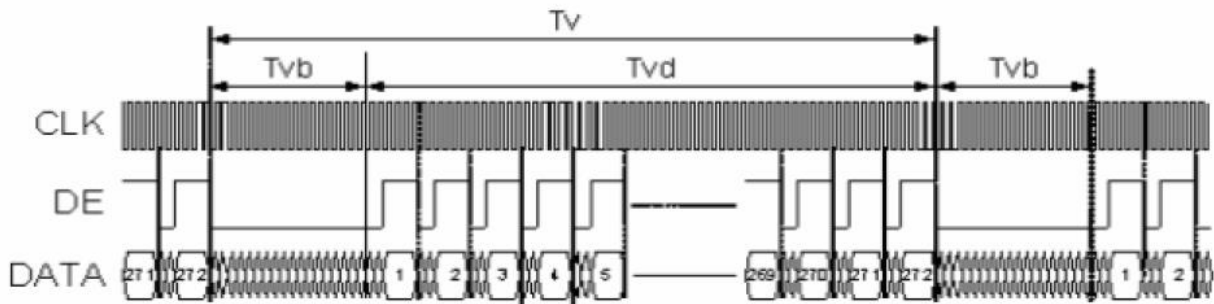

**12. Optical Characteristics**

The optical characteristics should be measured in a dark environment (≤ 1 lux) or equivalent state with the methods shown in Note (4).

Item		Symbol	Conditions	Min.	Typ.	Max.	Unit	Note	
Contrast Ratio		CR	Viewing Normal Angle	400	(500)	-	-	(2)	
Response Time		T_R		-	10	20	ms	(3)	
		T_F		-	15	30	ms		
Luminance(Center)		Y		$\theta_x=0^\circ, \theta_y=0^\circ$	310	(390)	-	cd/m ²	(4)
Brightness uniformity		BUNI			70	(75)	-	%	(5)
Color Chromaticity	White	W_x	$CR \geq 10$	(TBD)	(TBD)	(TBD)	-	(1),(4)	
		W_y		(TBD)	(TBD)	(TBD)	-		
Viewing Angle	Horizontal	θ_{x+}		60	(70)	-	deg.		
		θ_{x-}		60	(70)	-			
	Vertical	θ_{y+}		40	(50)	-			
		θ_{y-}	60	(70)	-				



Note (1) Definition of Viewing Angle (θ_x, θ_y):

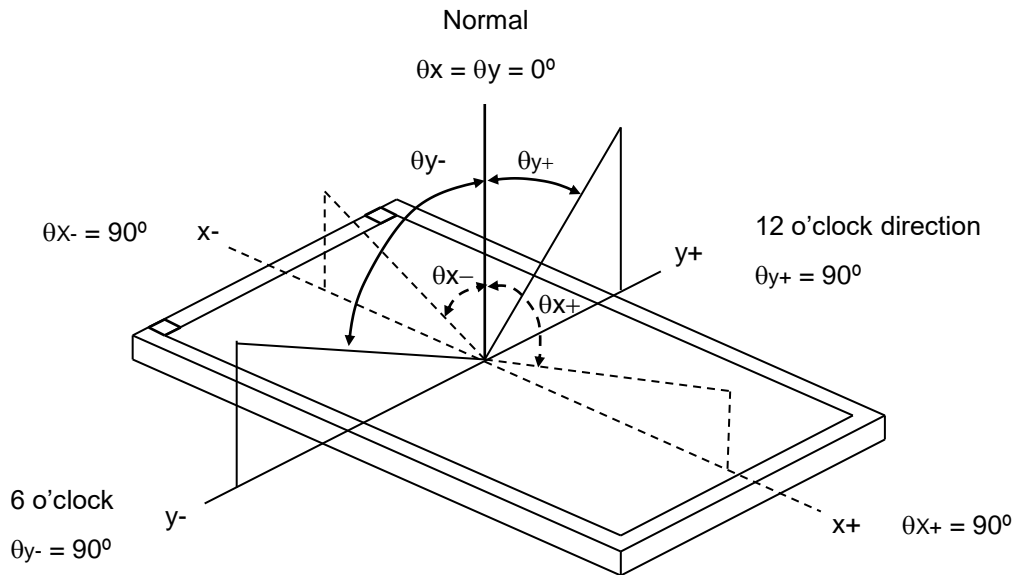

Note (2) Definition of Contrast Ratio (CR):

$$\text{Contrast ratio (CR)} = \frac{\text{Luminance measured when LCD on the "White" state}}{\text{Luminance measured when LCD on the "Black" state}}$$

Note (3) Definition of Response Time (T_R, T_F):

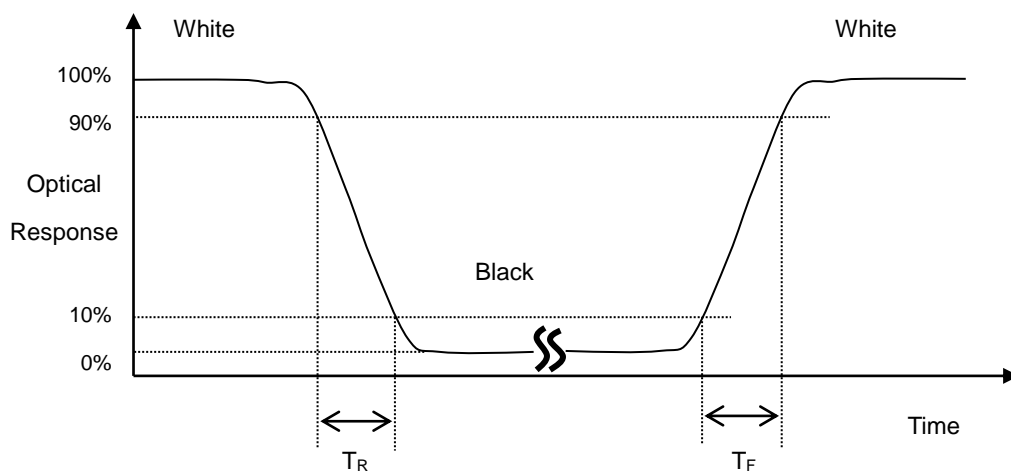



Note (4) Measurement Set-Up:

The LCD module should be stabilized at a given temperature for 30 minutes to avoid abrupt temperature change during measuring. In order to stabilize the luminance, the measurement should be executed after lighting Backlight for 30 minutes in a windless room.

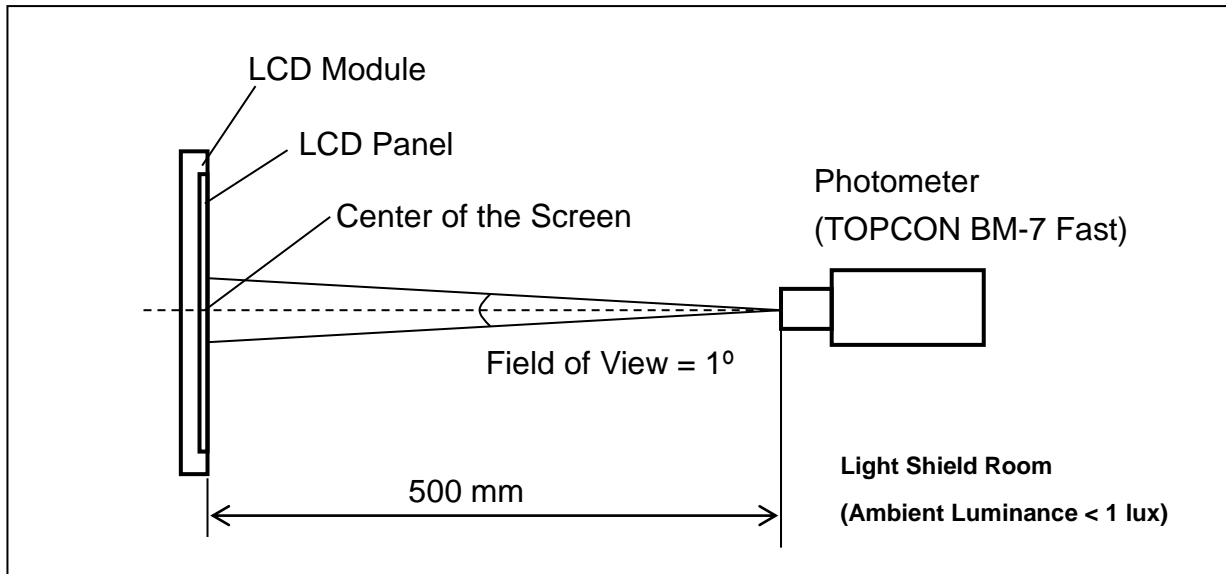

Note (5) Definition of brightness uniformity

$$\text{Brightness uniformity} = (\text{Min Luminance of 9 points}) / (\text{Max Luminance of 9 points}) \times 100\%$$

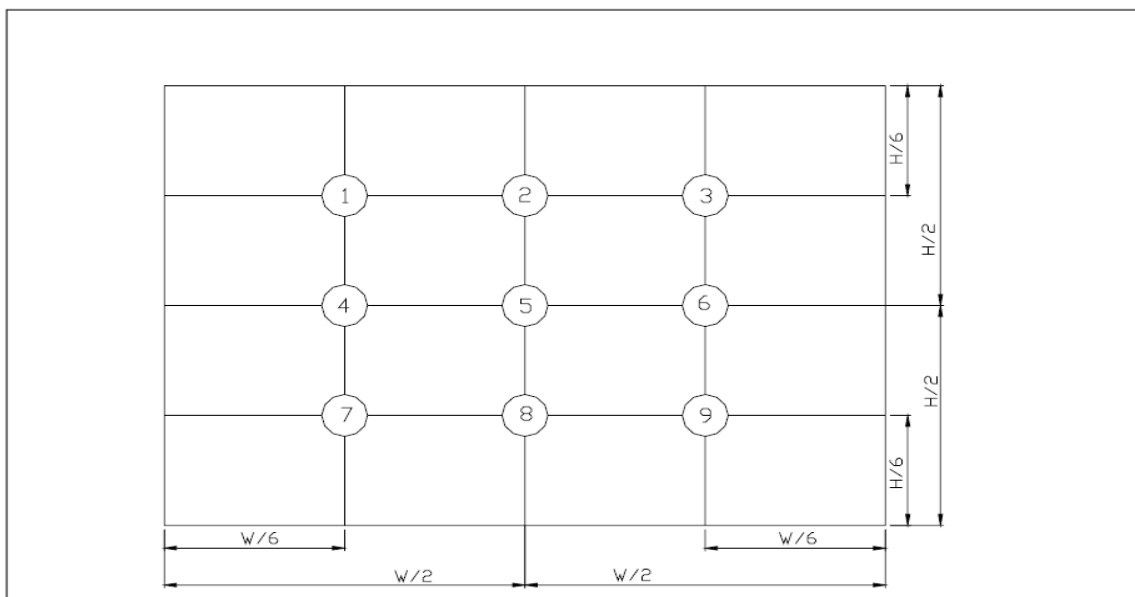

(單位 : mm)



13. Reliability Test

(Note3)

Item	Test Conditions	Remark
High Temperature Storage	Ta = 80°C 240 hrs	Note 1,Note 4
Low Temperature Storage	Ta = -30°C 240hrs	Note 1,Note 4
High Temperature Operation	Ts = 70°C 240hrs	Note 2,Note 4
Low Temperature Operation	Ta = -20°C 240hrs	Note 1,Note 4
Operate at High Temperature and Humidity	+60°C, 90% RH 240 hrs	Note 4
Thermal Shock	-30°C/30 min ~ +80°C/30 min for a total 100 cycles, Start with cold temperature and end with high temperature	Note 4
Vibration Test	Frequency range:10~55Hz Stroke:1.5mm Sweep:10Hz~55Hz~10Hz 2 hours for each direction of X. Y. Z. (6 hours for total)	
Mechanical Shock	100G 6ms,±X, ±Y, ±Z 3 times for each direction	
Package Vibration Test	Random Vibration : 0.015G*G/Hz from 5-200HZ, -6dB/Octave from 200-500HZ 2 hours for each direction of X. Y. Z. (6 hours for total)	
Package Drop Test	Height:60 cm 1 corner, 3 edges, 6 surfaces	
Electro Static Discharge	± 2KV, Human Body Mode, 100pF/1500Ω	

Note 1: Ta is the ambient temperature of samples.

Note 2: Ts is the temperature of panel's surface.

Note 3: In the standard condition, there shall be no practical problem that may affect the display function. After the reliability test, the product only guarantees operation, but doesn't guarantee all the cosmetic specification.

Note 4: Before cosmetic and function tests, the product must have enough recovery time, at least 2 hours at room temperature.



P-TEC

MODEL NO.

PT482743B-TLMWD-EMR12

SPEC ONLY

PAGE

21

14. Packaging

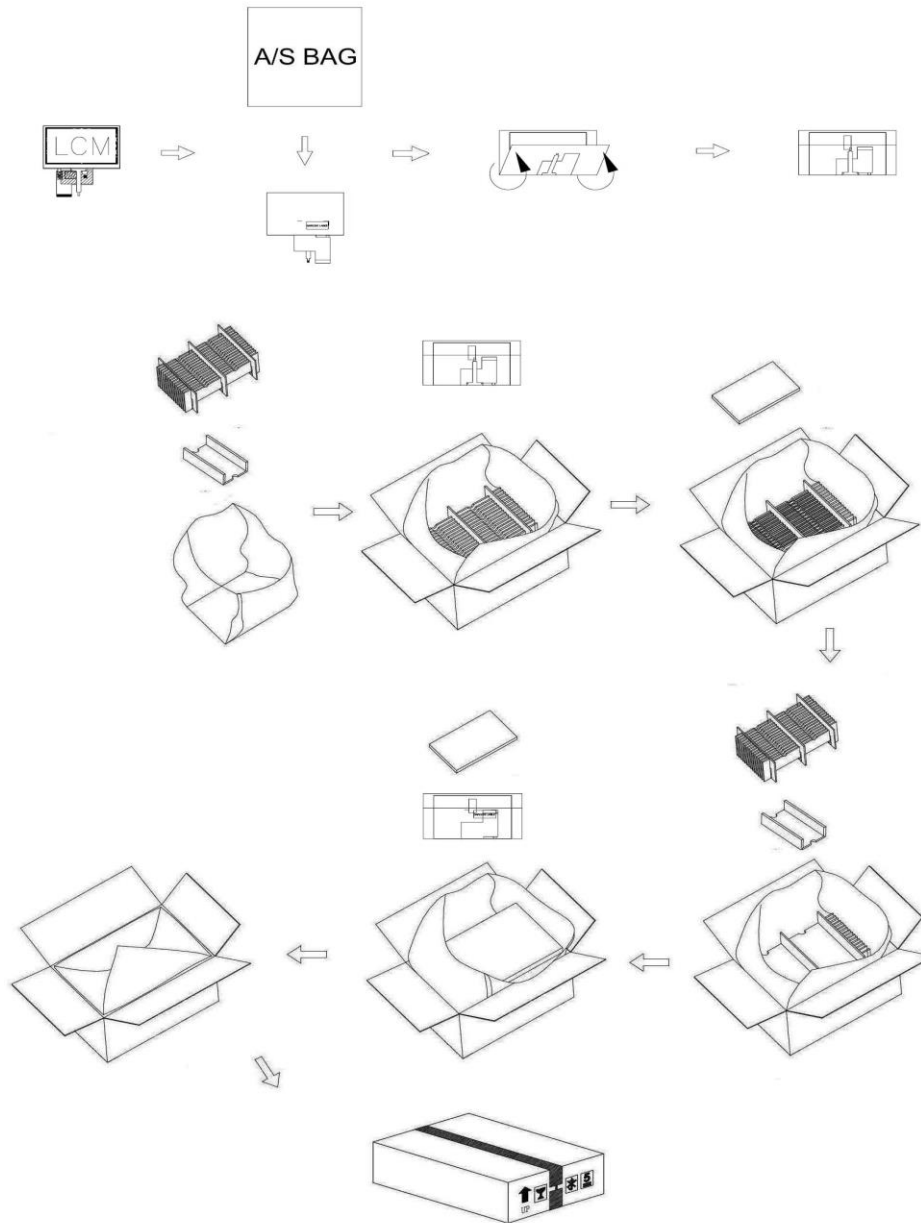

PARTS LIST

	ITEM	SIZE(LxW xH) unitmm	MATERIAL	Q.T.Y	NOTE
1	PARTITION	512.0x349.0x106.0	CORRUGATED PAPER	2	
2	CORRUGATED BAR	349.0x173.0	CORRUGATED PAPER	8	
3	DUST-PROOF BAG	700.0x530.0	PE	1	
4	CORRUGATED BOARD -1	510.0x343.0	CORRUGATED PAPER	2	
5	CORRUGATED BOARD -2	1152.0x512.0	CORRUGATED PAPER	1	
6	A/S BAG	132.0x117.0	PE	160	
7	CARTON	530.0x355.0x255.0	CORRUGATED PAPER	1	
8	PRODUCT	105.5x67.2x4.0		160	



15. Precautions

15.1 Assembly and Handling Precautions

- (1) Do not apply rough force such as bending or twisting to the module during assembly.
- (2) It's recommended to assemble or to install a module into the user's system in clean working areas. The dust and oil may cause electrical short or worsen the polarizer.
- (3) Don't apply pressure or impulse to the module to prevent the damage of LCD panel and Backlight.
- (4) Always follow the correct power-on sequence when the LCD module is turned on. This can prevent the damage and latch-up of the CMOS LSI chips.
- (5) Do not plug in or pull out the I/F connector while the module is in operation.
- (6) Do not disassemble the module.
- (7) Use a soft dry cloth without chemicals for cleaning, because the surface of polarizer is very soft and easily scratched.
- (8) Moisture can easily penetrate into LCD module and may cause the damage during operation.
- (9) High temperature or humidity may deteriorate the performance of LCD module. Please store LCD module in the specified storage conditions.
- (10) When ambient temperature is lower than 10°C, the display quality might be reduced. For example, the response time will become slow.

15.2 Safety Precautions

- (1) If the liquid crystal material leaks from the panel, it should be kept away from the eyes or mouth. In case of contact with hands, skin or clothes, it has to be washed away thoroughly with soap.
- (2) After the module's end of life, it is not harmful in case of normal operation and storage.

15.3 Terms of Warrant

- (1) Acceptance inspection period
The period is within one month after the arrival of contracted commodity at the buyer's factory site.
- (2) Applicable warrant period
The period is within twelve months since the date of shipping out under normal using and storage conditions.



15.4 Cautions for installing and assembling

Bezel edge must be positioned in the area between the Active area and View area. The bezel may press the touch screen and cause activation if the edge touches the active area. A gap of approximately 0.5mm is needed between the bezel and the top electrode. It may cause unexpected activation if the gap is too narrow. There is a tolerance of 0.2 to 0.3mm for the outside dimensions of the touch panel and tail. A gap must be made to absorb the tolerance in the case and connector.

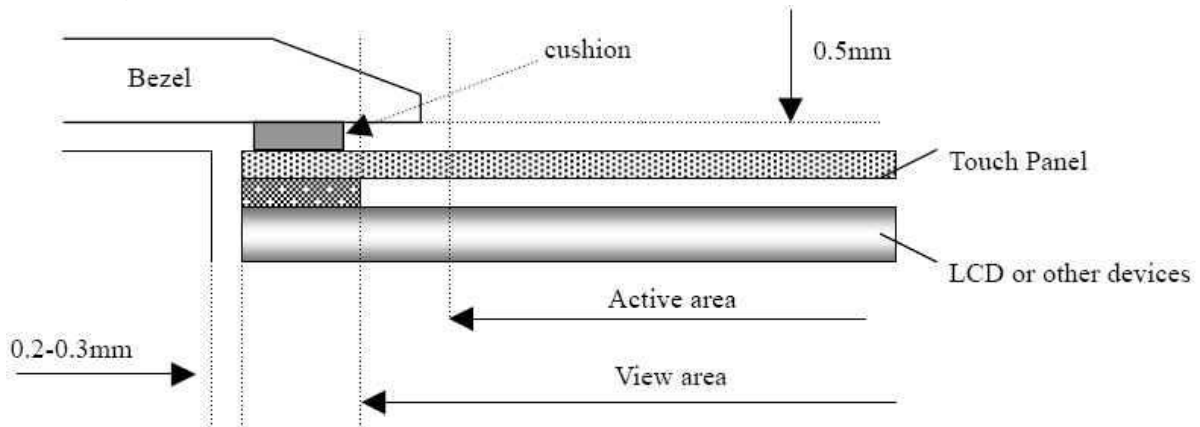

15.5 Operation Prohibit

Not Suggested Pen Input Position On Touch Panel

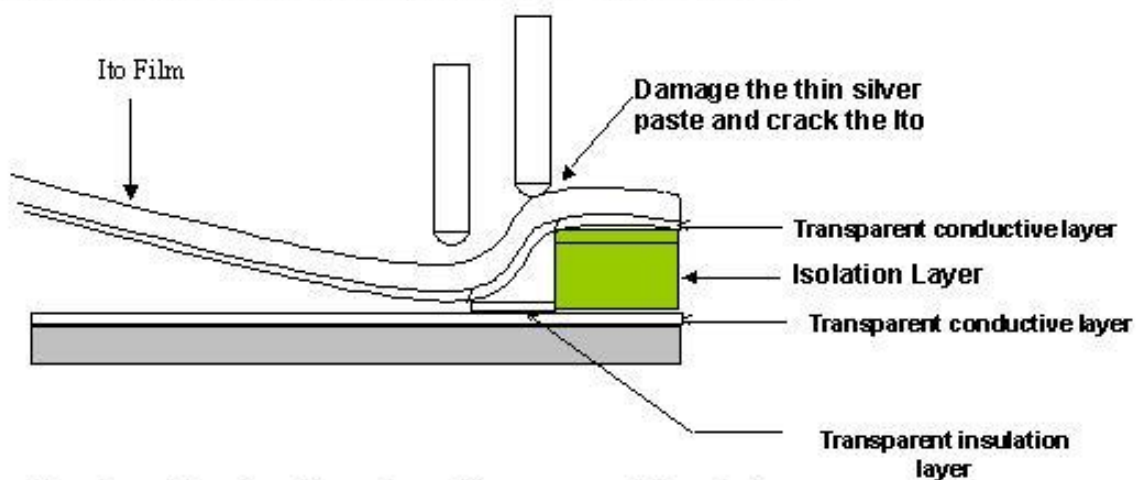

Pen input load on the edge of transparent insulation area might damage the ITO of ITO Pet- Film and reduce the durability of touch panel



17. Definition of Labels

The bar code nameplate is pasted on each module as illustration, and its definitions are as following explanation.

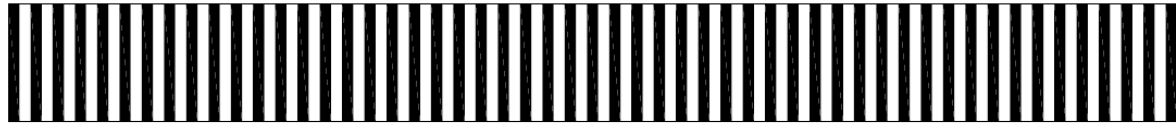

PT482743B-TLMWD-EMR12

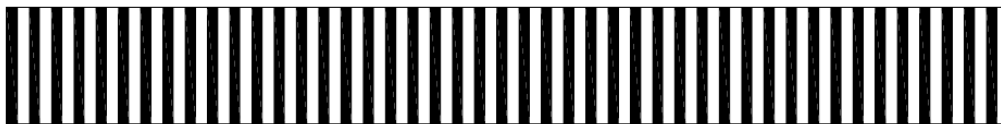

ABCDEFGHIJKLM

(a) Module Name: PT482743B-TLMWD-EMR12

(b) Serial ID:

A B C D E F G H I J K L M

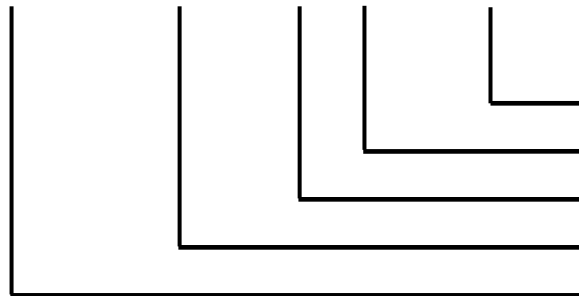

Serial No.
Revision Code
Factory Code
Manufactured Date
Screen Size

Serial ID includes the information as below:

(a) Screen size (Diagonal): Inch Code (ABCD)

3.5" → 0350

10.4" → 1040

(b) Manufactured Date: Year, Month, Day (EFG)

Year (E)

Year	2000	2001	2002	2003	2004	2005	2006	2007	2008	2009
Mark	0	1	2	3	4	5	6	7	8	9
Year	2010	2011	2012	2013	2014	2015	2016	2017	2018	2019
Mark	A	B	C	D	E	F	G	H	I	J



Month (F)

Month	Jan.	Feb.	Mar.	Apr.	May	Jun.	Jul.	Aug.	Sep.	Oct.	Nov.	Dec.
Mark	1	2	3	4	5	6	7	8	9	A	B	C

Day (G)

Day	1	2	3	4	5	6	7	8	9	10	11	12	13	14	15	16
Mark	1	2	3	4	5	6	7	8	9	A	B	C	D	E	F	G
Day	17	18	19	20	21	22	23	24	25	26	27	28	29	30	31	
Mark	H	I	J	K	L	M	N	O	P	Q	R	S	T	U	V	

(c) Factory Code (H):

For P-TEC internal use.

(d) Revision Code (I):

Cover all the change, for example: 1: Rev.1, 2: Rev.2, 3: Rev.3...etc.

(e) Serial No. (JKLM):

Manufacturing sequence of product, for example: 0001~9999.



18. Incoming Inspection Standards

18.1 Inspection Parameters

1. Incoming Inspection

Both parties agree that the inspection specifications of TFT-LCD Modules (hereinafter known as "Modules") stipulated hereunder is the only and final standard applicable in the process of inspection. P-TEC shall be under no liability or obligation (including incidental loss, products liability or other consequential loss) whatsoever for any defect in quality or performance or shortage in quantity of the Modules that have passed such inspection.

2. Liability

2.1 Inspection Deadline

The Customer should inspect the Modules either at the Delivery Point or within twenty (20) calendar days after arrival at the Delivery Destination.

2.2 Notification of Rejection

The Customer may reject one or more defective or non-conforming Modules if the Modules fail to meet the AQL (Acceptable Quality Level) and pass the inspection. In that case, the customer should notify P-TEC of the rejection by either documents or mail within in three (3) business days from the date of reception of the Modules. Otherwise, the Modules shall be deemed to have met the AQL and passed the inspection.

3. Inspection Specifications

Both parties agree that the inspection shall contain and follow the inspection specifications stipulated in the attachment, including:

3.1 Scope

3.2 Sampling Plan

3.3 Panel Inspection Condition

3.4 Display Quality

3.5 Mechanics Specifications

3.6 Notification for Storage Handling

4. Limited Warranty

P-TEC represents and warrants that all Modules shall (i) conform to the specifications set hereunder, and (ii) be free from any defects in material and workmanship for twelve (12) months after the Customer's acceptance or deemed acceptance. P-TEC will replace, rework or refund the Customer for the defective or non-conforming Modules at P-TEC's option, provided that the Customer (i) promptly informs P-TEC of the defects or non-conformities within the warranty period, (ii) complies with the specifications and conditions hereunder, and (iii) complies with P-TEC's procedure for Modules replacement, reworking and/or return. The warranty period for the Modules replaced



P-TEC

MODEL NO.

PAGE

PT482743B-TLMWD-EMR12

SPEC ONLY

28

or reworked shall be the remaining term for such Modules.

5. THE WARRANTIES AND REMEDIES SET FORTH ABOVE ARE EXCLUSIVE AND IN LIEU OF ALL OTHER WARRANTIES, TERMS OR CONDITIONS, EXPRESS OR IMPLIED, EITHER IN FACT OR BY OPERATION OF LAW, STATUTORY OR OTHERWISE, INCLUDING WARRANTIES OR CONDITIONS OF MERCHANTABILITY AND FITNESS FOR A PARTICULAR PURPOSE, ALL OF WHICH ARE EXPRESSLY DISCLAIMED. P-TEC'S WARRANTIES HEREIN APPLY ONLY TO THE CUSTOMER AND ARE NOT TO BE EXTENDED TO ANY THIRD PARTY.

6. Governing Law

This Agreement shall be governed and construed in accordance with the laws of the Republic of China. Both parties agree to submit any dispute, which cannot be amicably resolved, to Hsinchu District Court for the first instance.



Inspection Specifications

1. Scope

Specifications contain

- 1.1 Display Quality Evaluation
- 1.2 Mechanics Specification

2. Sampling Plan

Unless there is other agreement, the sampling plan for incoming inspection shall follow MIL-STD-105E.

- 2.1 Lot size: Quantity per shipment as one lot (different model as different lot).
- 2.2 Sampling type: Normal inspection, single sampling.
- 2.3 Sampling level: Level II.
- 2.4 AQL: Acceptable Quality Level
 - Major defect: AQL=0.65
 - Minor defect: AQL=1.0

3. Panel Inspection Condition

3.1 Environment:

Room Temperature: $25\pm 5^{\circ}\text{C}$.

Humidity: $65\pm 5\%$ RH.

Illumination: 300 ~ 700 Lux.

3.2 Inspection Distance:

35 ± 5 cm

3.3 Inspection Angle:

The vision of inspector should be perpendicular to the surface of the Module.

3.4 Inspection time:

Perceptibility Test Time: 20 seconds max.

4. Display Quality

4.1 Function Related:

The function defects of line defect, abnormal display, and no display are considered Major defects.



4.2 Bright/Dark Dots:

Defect Type	Specification	Major	Minor
Bright Dots	$N \leq 1$		•
Dark Dots	$N \leq 2$		•
Total Bright and Dark Dots	$N \leq 2$		•

Note: 1: The definition of dot: The size of a defective dot over 1/2 of whole dot is regarded as one defective dot.

Bright dot: Dots appear bright and unchanged in size in which LCD panel is displaying under black pattern.

The bright dot defect must be visible through 2% ND filter

Dark dot: Dots appear dark and unchanged in size in which LCD panel is displaying under pure red, green, blue pattern.

4.3 Pixel Definition:

R		B	R	G	B	R	G	B		Dot Defect
R	G	B	R		B	R	G	B		Adjacent Dot Defect
	R	G		R	G	B		Cluster		

Note

1: If pixel or partial sub-pixel defects exceed 50% of the affected pixel or sub-pixel area, it shall be considered as 1 defect.



Note 2: There should be no distinct non-uniformity visible through 2% ND Filter within 2 sec inspection times.

4.4 Visual Inspection specifications:

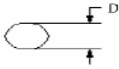
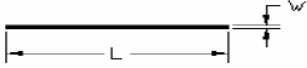

<u>Defect Type</u>		<u>Specification Size</u>	<u>Count(N)</u>	Major	Minor
Dot Shape (Particle · Scratch and Bubbles in display area) 		$D \leq 0.1 \text{ mm}$	Ignored		•
		$0.10\text{mm} < D \leq 0.4\text{mm}$	$N \leq 2$		
		$D > 0.4\text{mm}$	$N=0$		
Line Shape (Particles · Scratch · Lint and Bubbles in display area) 		$W \leq 0.01 \text{ mm}$	Ignored		•
		$0.01\text{mm} < W \leq 0.05\text{mm}$ and $L \leq 3\text{mm}$	$N \leq 3$		
		$W > 0.05\text{mm}$ or $L > 3 \text{ mm}$	$N=0$		
Bubble in cell (active area)		It should be found by eyes			•
Bezel	Scratch	No harm			•
	Dirt				•
	Wrap				•
	Sunken				•
Label	No label	No			•
	Inverted label				•
	Broken				•
	Dirt	Word can be read.			•
	Not clear	No			•
	Word out of shape				•
	Mistake	No			•
	Position	Be attached on right position			•
Screw	Not enough	No			•
	Limp	No			•

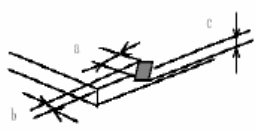
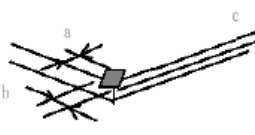
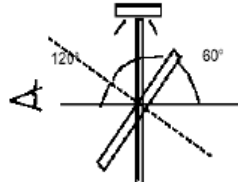

Item		Specification/Description			Note
Touch Panel	Scratch	L(mm)	W(mm)	Acceptable number	Note:1
		$L \leq 10$	$W < 0.05$	Disregard	
			$0.05 \leq W < 0.1$	$N \leq 4$	
		$W \geq 0.1$	0		
	Foreign Materials (Linear shape)	$L \leq 10$	$W < 0.05$	Disregard	Note:1
			$0.05 \leq W < 0.1$	$N \leq 3$	
			$W \geq 0.1$	0	
	Foreign Materials (Circular shape)	Dimension(mm)		Acceptable number	Note:2
		$D \leq 0.25$		Disregard	
		$0.25 < D \leq 0.5$		$N \leq 6$	
	$D > 0.5$		0		
Glass chipping		$a \leq 5\text{mm}$		Note:3	
		$b \leq 3\text{mm}$			
		$a \leq 3\text{mm}$		Note:3	
		$b \leq 3\text{mm}$			
		$c \leq t$ (t : Glass think)			
		$c \leq t$ (t : Glass think)			
Newton-ring	(In case of doubtful situations) Observe on 60° from the product surface under a while Fluorescent lamp(3-wavelength lamp).	Average diameter $\leq 1/3$ Touch Panel area Disregard.		Note:3	
					
Membrane Drum		$H \leq 0.35\text{mm}$			



Note1.

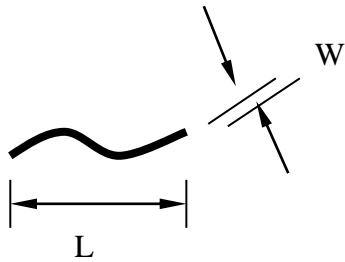

Note2.

D : Diameter $D=(a+b)/2$

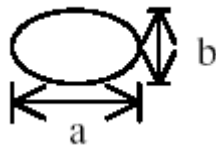

Note3.

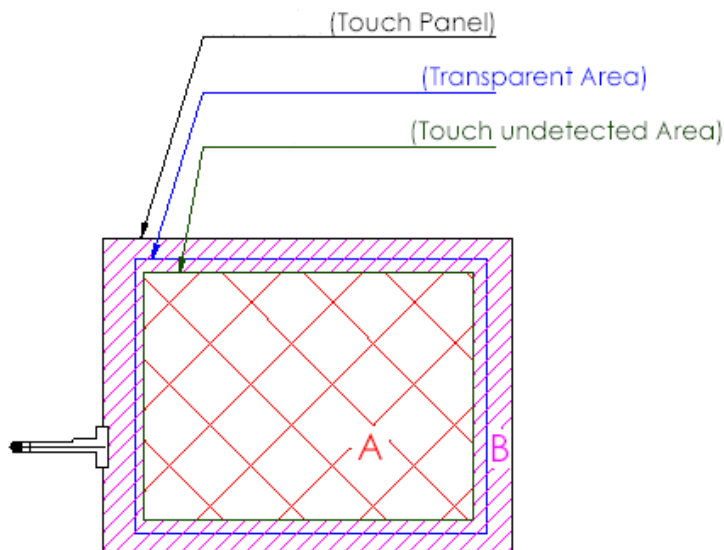

A area : Without any defect point effect on normal operation.

B area : None-specify



Connector	Connection status	No bend on pins and damage		•
FPC/FFC	Broken	No		•

Note: Extraneous substance and scratch not affecting the display of image, for instance, extraneous substance under polarizer film but outside the display area, or scratch on metal bezel and backlight module or polarizer film outside the display area, shall not be considered as defective or non-conforming.

5. Mechanics specifications

As for the outside dimensions and weight of the Modules, please refer to product specifications for more details.

6. Notification for Storage Handling

6.1 Storage:

6.1.1 Environment condition must be within the product specifications, otherwise the Module might be damaged.

6.1.2 Pile of stacking shall follow the instruction of P-TEC.

6.2 Handling:

6.2.1 Twisting or Bending of the Module is prohibited.

6.2.2 All chemicals are unfit for use unless otherwise instructed by P-TEC.

6.2.3 Plugging in & unplugging:

The power must be turned off before plugging in or unplugging the Module.

6.2.4 ESD protection:

The Module must not be touched without proper grounding.

6.2.5 High Voltage:

The rear side of Module must not be touched without protection.

6.2.6 Power sequence:

Shall follow the instruction of P-TEC.



P-TEC

MODEL NO.

PAGE

PT482743B-TLMWD-EMR12

SPEC ONLY

35

18.2 Handling of LCM

- (1) Don't give external shock.
- (2) Don't apply excessive force on the surface.
- (3) Liquid in LCD is hazardous substance. Must not lick and swallow. when the liquid is attach to your hand, skin, cloth etc. Wash it out thoroughly and immediately.
- (4) Don't operate it above the absolute maximum rating.
- (5) Don't disassemble the LCM.