

PNP SILICON PLANAR EPITAXIAL TRANSISTOR

MPSL51
TO-92
CBE

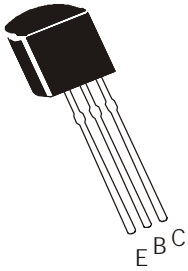

Amplifier Transistor.

ABSOLUTE MAXIMUM RATINGS.

DESCRIPTION	SYMBOL	VALUE	UNIT
Collector -Base Voltage	VCBO	100	V
Collector -Emitter Voltage	VCEO	100	V
Emitter -Base Voltage	VEBO	4.0	V
Collector Current Continuous	IC	600	mA
Power Dissipation @ Ta=25 degC	PD	625	mW
Derate Above 25 deg C		5.0	mw/deg C
Power Dissipation @ Tc=25 degC	PD	1.5	W
Derate Above 25 deg C		12	mw/deg C
Operating And Storage Junction Temperature Range	Tj, Tstg	-55 to +150	deg C

ELECTRICAL CHARACTERISTICS (Ta=25 deg C Unless Otherwise Specified)

DESCRIPTION	SYMBOL	TEST CONDITION	MIN	TYP	MAX	UNIT
Collector -Emitter Voltage	VCEO*	IC=1mA, IB=0	100	-	-	V
Collector -Base Voltage	VCBO	IC=100uA, IE=0	100	-	-	V
Emitter -Base Voltage	VEBO	IE=10uA, IC=0	4.0	-	-	V
Collector-Cut off Current	ICBO	VCB=50V, IE=0	-	-	1.0	uA
Emitter-Cut off Current	IEBO	VEB=3V, IC=0	-	-	100	nA
DC Current Gain	hFE*	IC=50mA, VCE=5V	40	-	250	

ELECTRICAL CHARACTERISTICS (Ta=25 deg C Unless Otherwise Specified)

MPSL51

DESCRIPTION	SYMBOL	TEST CONDITION	MIN	TYP	MAX	UNIT
Collector Emitter Saturation Voltage	VCE(Sat)	IC=10mA, IB=1mA	-	-	0.25	V
		IC=50mA, IB=5mA*	-	-	0.3	V
Base Emitter Saturation Voltage	VBE(Sat)	IC=10mA, IB=1mA	-	-	1.2	V
		IC=50mA, IB=5mA*	-	-	1.2	V
Dynamic Characteristics						
Small Signal Current Gain	hfe	IC=1mA, VCE=10V f=1kHz	20	-	-	
Transition Frequency	ft*	VCE=10V, IC=10mA, f=100MHz	60	-	-	MHz
output Capacitance	Cobo	VCB=10V, IE=0 f=1MHz	-	-	8.0	pF

*Pulse Test: Pulse Width=300us, Duty Cycle=2%

TO-92 Plastic Package

TO-92 Transistors on Tape and Ammo Pack

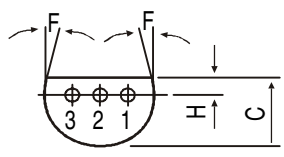
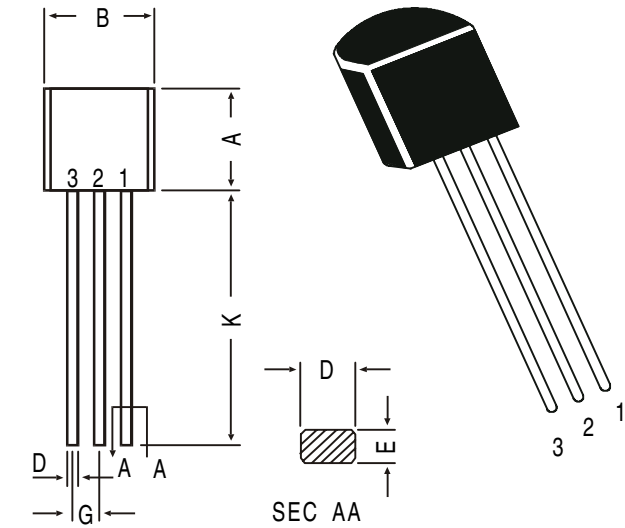

- PIN CONFIGURATION**
1. COLLECTOR
 2. BASE
 3. EMITTER

All dimensions in mm.

DIM	MIN.	MAX.
A	4.32	5.33
B	4.45	5.20
C	3.18	4.19
D	0.41	0.55
E	0.35	0.50
F	5 DEG	
G	1.14	1.40
H	1.14	1.53
K	12.70	—

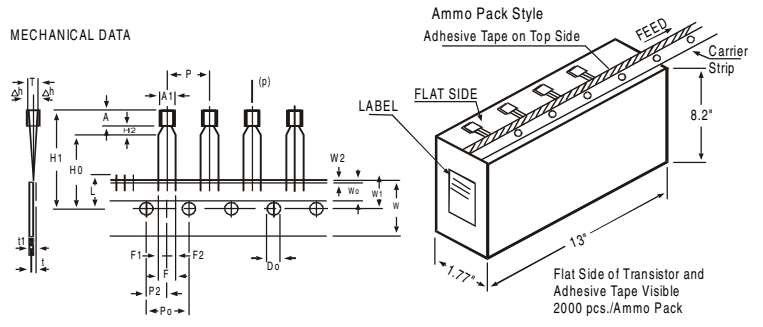

All dimensions in mm unless specified otherwise

ITEM	SYMBOL	SPECIFICATION				REMARKS
		MIN.	NOM.	MAX.	TOL.	
BODY WIDTH	A1	4.0		4.8		
BODY HEIGHT	A	4.8		5.2		
BODY THICKNESS	T	3.9		4.2		
PITCH OF COMPONENT	P		12.7		±1	
FEED HOLE PITCH	Po		12.7		±0.3	
FEED HOLE CENTRE TO COMPONENT CENTRE	P2		6.35		±0.4	
DISTANCE BETWEEN OUTER LEADS	F	5.08			+0.6 -0.2	
COMPONENT ALIGNMENT	Δh	0		1		AT TOP OF BODY
TAPE WIDTH	W	18			±0.5	
HOLD-DOWN TAPE WIDTH	W0	6			±0.2	
HOLE POSITION	W1	9			+0.7 -0.5	
HOLD-DOWN TAPE POSITION	W2	0.5			±0.2	
LEAD WIRE CLINCH HEIGHT	Ho	16			±0.5	
COMPONENT HEIGHT	H1			23.25		
LENGTH OF SNIPPED LEADS	L			11.0		
FEED HOLE DIAMETER	Do		4		±0.2	
TOTAL TAPE THICKNESS	t			1.2		±0.3 - 0.6
LEAD - TO - LEAD DISTANCE F1,	F2		2.54		+0.4 -0.1	
CLINCH HEIGHT	H2			3		
PULL - OUT FORCE	(P)	6N				

NOTES

1. MAXIMUM ALIGNMENT DEVIATION BETWEEN LEADS NOT TO BE GREATER THAN 0.2 mm.
2. MAXIMUM NON-CUMULATIVE VARIATION BETWEEN TAPE FEED HOLES SHALL NOT EXCEED 1 mm IN 20 PITCHES.
3. HOLDDOWN TAPE NOT TO EXCEED BEYOND THE EDGE(S) OF CARRIER TAPE AND THERE SHALL BE NO EXPOSURE OF ADHESIVE.
4. NO MORE THAN 3 CONSECUTIVE MISSING COMPONENTS ARE PERMITTED.
5. A TAPE TRAILER, HAVING AT LEAST THREE FEED HOLES ARE REQUIRED AFTER THE LAST COMPONENT.
6. SPLICES SHALL NOT INTERFERE WITH THE SPROCKET FEED HOLES.

Packing Detail

PACKAGE	STANDARD PACK		INNER CARTON BOX		OUTER CARTON BOX		
	Details	Net Weight/Qty	Size	Qty	Size	Qty	Gr Wt
TO-92 Bulk	1K/polybag	200 gm/1K pcs	3" x 7.5" x 7.5"	5.0K	17" x 15" x 13.5"	80.0K	23 kgs
TO-92 T&A	2K/ammo box	645 gm/2K pcs	12.5" x 8" x 1.8"	2.0K	17" x 15" x 13.5"	32.0K	12.5 kgs

Customer Notes

Disclaimer

The product information and the selection guides facilitate selection of the CDIL's Discrete Semiconductor Device(s) best suited for application in your product(s) as per your requirement. It is recommended that you completely review our Data Sheet(s) so as to confirm that the Device(s) meet functionality parameters for your application. The information furnished on the CDIL Web Site/CDare believed to be accurate and reliable. CDIL however, does not assume responsibility for inaccuracies or incomplete information. Furthermore, CDIL does not assume liability whatsoever, arising out of the application or use of any CDIL product; neither does it convey any license under its patent rights nor rights of others. These products are not designed for use in life saving/support appliances or systems. CDIL customers selling these products (either as individual Discrete Semiconductor Devices or incorporated in their end products), in any life saving/support appliances or systems or applications do so at their own risk and CDIL will not be responsible for any damages resulting from such sale(s).

CDIL strives for continuous improvement and reserves the right to change the specifications of its products without prior notice.



CDIL is a registered Trademark of

Continental Device India Limited

C-120 Naraina Industrial Area, New Delhi 110 028, India.

Telephone + 91-11-2579 6150, 5141 1112 Fax + 91-11-2579 5290, 5141 1119

email@cdil.com www.cdilsemi.com