

# LBAT40-04LT1G

## S-LBAT40-04LT1G

Schottky barrier diode

### 1. FEATURES

- Small surfacemounting type.
- Ultra low VF (VF =0.5V Typ. at 0.2A)
- High reliability.
- We declare that the material of product compliance with RoHS requirements and Halogen Free.
- S- prefix for automotive and other applications requiring unique site and control change requirements; AEC-Q101 qualified and PPAP capable.

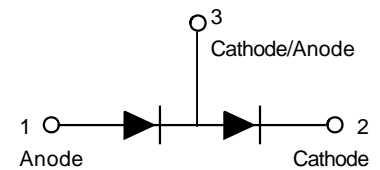
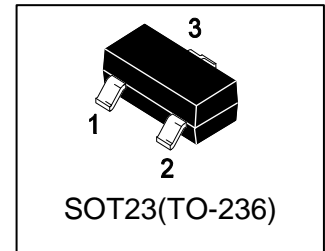

### 2. DEVICE MARKING AND RESISTOR VALUES

Device	Marking	Shipping
LBAT40-04LT1G	6S	3000/Tape&Reel

### 3. MAXIMUM RATINGS(Ta = 25°C)

Parameter	Symbol	Limits	Unit
Continuous reverse voltage	VR	40	V
Peak Forward Current	IF	350	mA
Repetitive Peak forward surge current	IFSM	1500	mA

### 4. THERMAL CHARACTERISTICS

Parameter	Symbol	Limits	Unit
Total Device Dissipation, FR-5 Board (Note 1) @ TA = 25°C Derate above 25°C	PD	225 1.8	mW mW/°C
Thermal Resistance, Junction-to-Ambient(Note 1)	RθJA	556	°C/W
Total Device Dissipation, Alumina Substrate(Note 2) @ TA = 25°C Derate above 25°C	PD	300 2.4	mW mW/°C
Thermal Resistance, Junction-to-Ambient(Note 2)	RθJA	417	°C/W
Junction and Storage temperature	TJ,Tstg	-55~+150	°C

1. FR-5 = 1.0×0.75×0.062 in.

2. Alumina = 0.4 x 0.3 x 0.024 in. 99.5% alumina.

**5. ELECTRICAL CHARACTERISTICS (Ta= 25°C)**

<b>CHARACTERISTICS</b>	<b>Symbol</b>	<b>Min</b>	<b>Max</b>	<b>Unit</b>
Reverse Voltage Leakage Current (VR=25V)	IR	-	1	μA
Reverse Breakdown Voltage (IBR = 10 μA)	VBR	40	-	V
Forward voltage (IF =20mA)	VF	-	370	mV
(IF =200mA)		-	600	

**6.ELECTRICAL CHARACTERISTICS CURVES**

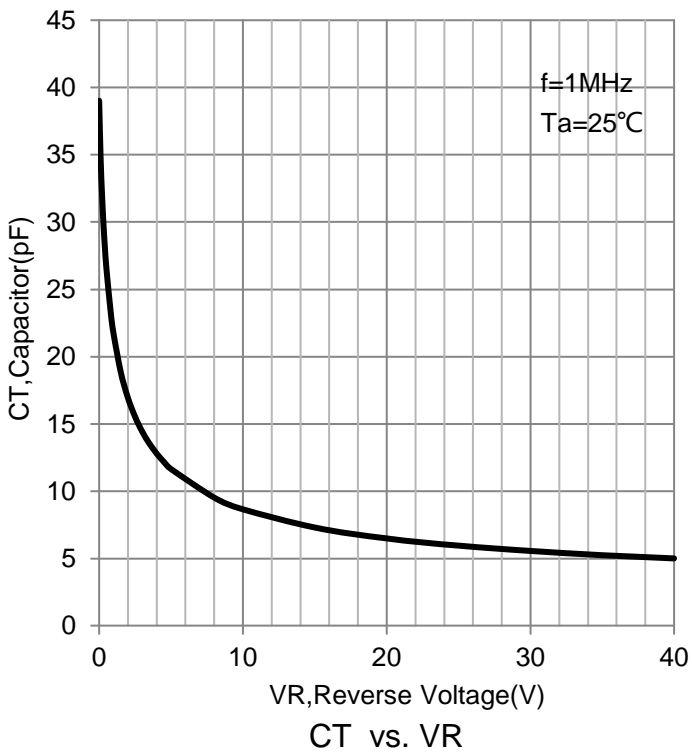
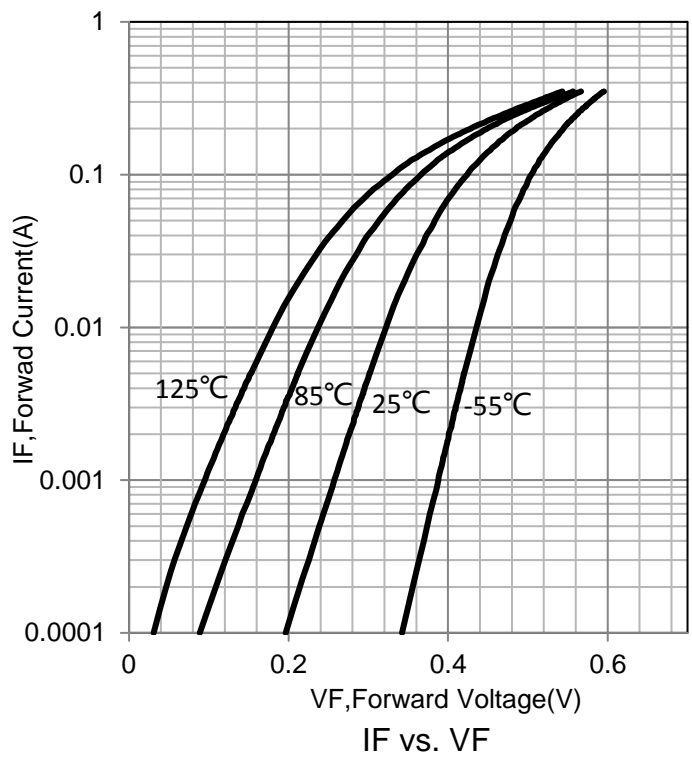
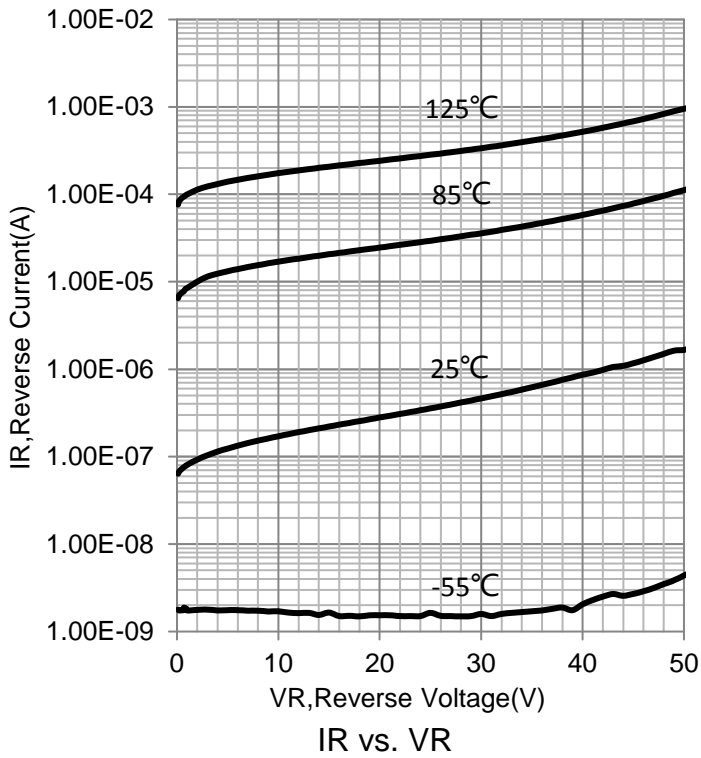

### 7. OUTLINE AND DIMENSIONS

Notes:

1. DIMENSIONING AND TOLERANCING PER ANSI Y14.5M, 1982.
2. CONTROLLING DIMENSION: MILLIMETERS.
3. MAXIMUM LEAD THICKNESS INCLUDES LEAD FINISH. MINIMUM LEAD THICKNESS IS THE MINIMUM THICKNESS OF BASE MATERIAL.
4. DIMENSIONS D AND E DO NOT INCLUDE MOLD FLASH, PROTRUSIONS OR GATE BURRS.

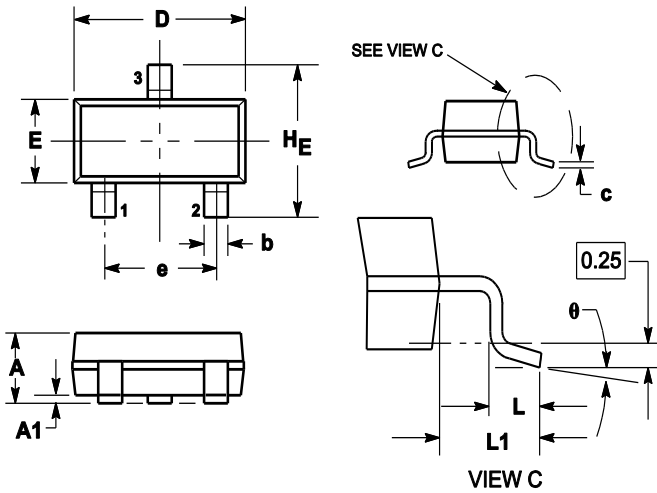

DIM	MILLIMETERS			INCHES		
	MIN	NOM	MAX	MIN	NOM	MAX
A	0.89	1	1.11	0.035	0.04	0.044
A1	0.01	0.06	0.1	0.001	0.002	0.004
b	0.37	0.44	0.5	0.015	0.018	0.02
c	0.09	0.13	0.18	0.003	0.005	0.007
D	2.80	2.9	3.04	0.11	0.114	0.12
E	1.20	1.3	1.4	0.047	0.051	0.055
e	1.78	1.9	2.04	0.07	0.075	0.081
L	0.10	0.2	0.3	0.004	0.008	0.012
L1	0.35	0.54	0.69	0.014	0.021	0.029
HE	2.10	2.4	2.64	0.083	0.094	0.104
theta	0°	---	10°	0°	---	10°

### 8. SOLDERING FOOTPRINT

