

Customer Information Sheet

DRAWING No.: M80-941XXXX SHEET 2 OF 2

IF IN DOUBT - ASK

©

NOT TO SCALE

THIRD ANGLE PROJECTION

ALL DIMENSIONS IN mm

ORDER CODE:

M80-941XXXX

TOTAL No. OF CONTACTS
06, 08, 10, 12, 14,
20, 26, 34, 42, 50

FINISH
05 - GOLD CLIP, GOLD SHELL
42 - GOLD CLIP, 100% TIN SHELL

SPECIFICATIONS:

MATERIAL:
CABLE HOOD = 30% GLASS-FILLED POLYAMIDE 46
DATAMATE MOULDING = 30% GLASS-FILLED PPS,
UL94V-0, BLACK
CONTACT CLIP = BERYLLIUM COPPER
CONTACT SHELL = BRASS
JACKSCREW = STAINLESS STEEL
CABLE HOOD FIXING SCREW = MILD STEEL

FINISH:
05 = 0.3µm GOLD CLIP, 0.25-0.3µm GOLD SHELL
42 = 0.3µm GOLD CLIP, 3.5-5.0µm 100% TIN
OVER NICKEL SHELL

CABLE HOOD FIXING SCREW = CHEMI-BLACK

ELECTRICAL:
CURRENT RATING AT 25°C = 3.0A MAX
CURRENT RATING AT 85°C = 2.2A MAX
WORKING VOLTAGE = 800V AC/DC
VOLTAGE PROOF = 1200V AC/DC
CONTACT RESISTANCE = 25mΩ MAX
INSULATION RESISTANCE = 100MΩ MIN

MECHANICAL:
DURABILITY = 500 OPERATIONS

ENVIRONMENTAL:
TEMPERATURE RANGE = -55°C TO +125°C

PACKING:
BAG

FOR COMPLETE SPECIFICATION, SEE COMPONENT SPECIFICATION C005XX (LATEST ISSUE)

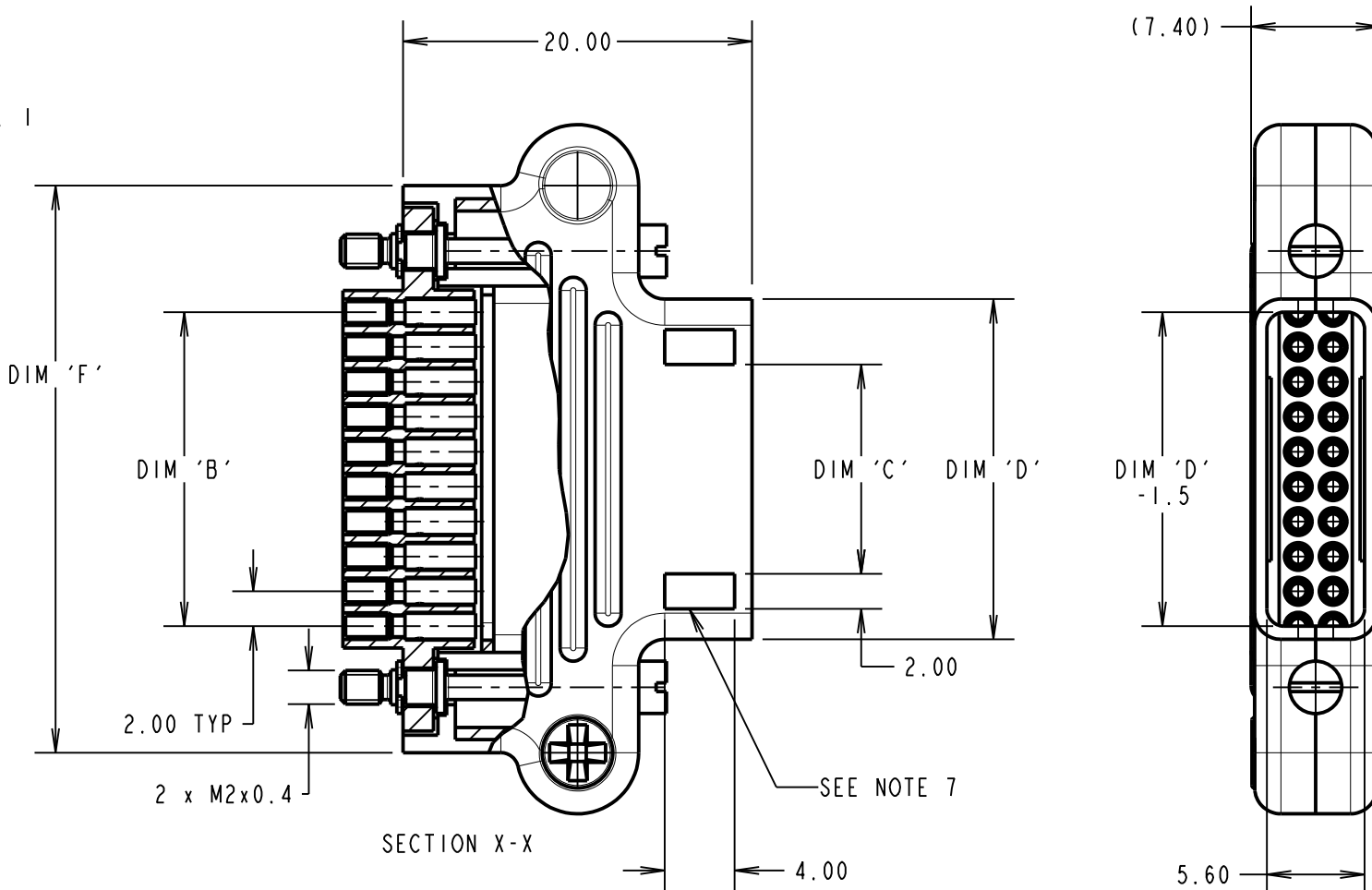
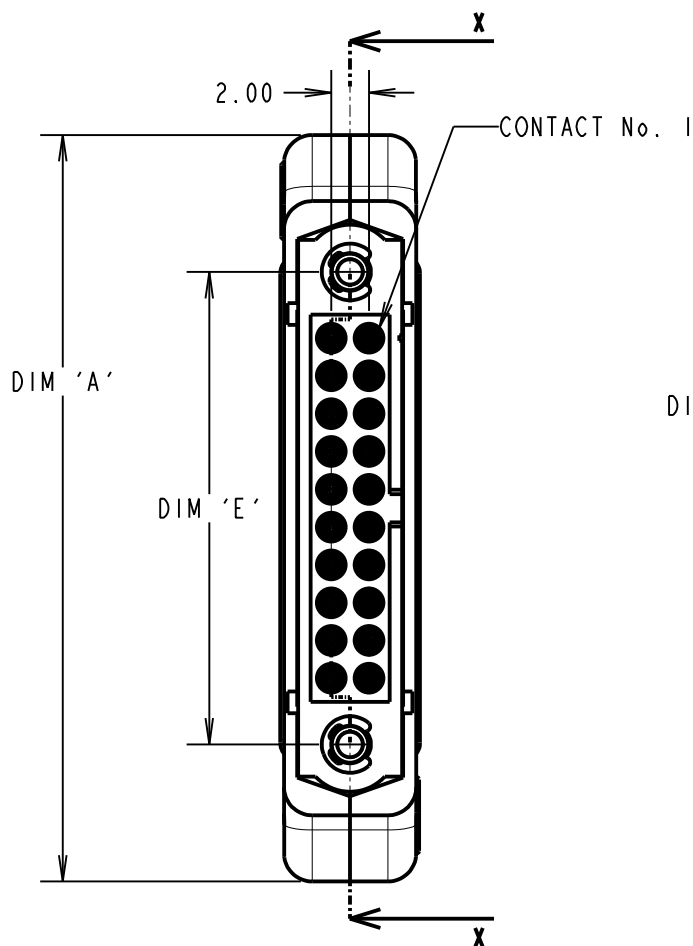

NOTES:

- CONNECTORS ARE SUPPLIED WITH CONTACTS, CABLE HOOD SET, AND CABLE HOOD FIXING SCREWS LOOSE.
- FOR EXTRA CONTACTS, USE PART NUMBER M80-01100XX (XX = 05 FOR GOLD FINISH, 01 FOR TIN FINISH).
- RECOMMENDED WIRE TYPE = BS 3G 210 TYPE A, PTFE INSULATED 22 AWG. MAX INSULATION DIAMETER = Ø1.10mm, STRIP WIRE BY 2.00mm.
- RECOMMENDED HAND CRIMP TOOL = M22520/2-01 WITH POSITIONER T5747. REFER TO TOOLING INSTRUCTION SHEET IS-01 FOR COMPLETE CRIMPING INSTRUCTIONS.
- CONTACT INSERTION AND EXTRACTION TOOL = Z80-280. REFER TO TOOLING INSTRUCTION SHEET IS-25 FOR ASSEMBLY INSTRUCTIONS.
- NO CABLE TIE SLOTS ON M80-94106XX AND M80-94108XX.

PART NUMBER	No. OF CONTACTS	PART DIMENSIONS					
		DIM 'A'	DIM 'B'	DIM 'C'	DIM 'D'	DIM 'E'	DIM 'F'
M80-94106XX	6	25.50	4.00	N/A	5.50	11.00	18.50
M80-94108XX	8	27.50	6.00	N/A	7.50	13.00	20.50
M80-94110XX	10	29.50	8.00	2.00	9.50	15.00	22.50
M80-94112XX	12	31.50	10.00	4.00	11.50	17.00	24.50
M80-94114XX	14	33.50	12.00	6.00	13.50	19.00	26.50
M80-94120XX	20	39.50	18.00	12.00	19.50	25.00	32.50
M80-94126XX	26	45.50	24.00	18.00	22.50	31.00	38.50
M80-94134XX	34	53.50	32.00	26.00	33.50	39.00	46.50
M80-94142XX	42	61.50	40.00	34.00	41.50	47.00	54.50
M80-94150XX	50	69.50	48.00	42.00	49.50	55.00	62.50

FM	7	26.03.18	20940
NAME	ISS.	DATE	C/NOTE
APPROVED: F. MCGOWAN			
CHECKED: S. BENNETT			
DRAWN: N. CODLING			
CUSTOMER REF.:			
ASSEMBLY DRG:			

HARWIN

www.harwin.com
technical@harwin.com

THIS DRAWING AND ANY INFORMATION OR DESCRIPTIVE MATTER SET OUT HEREON ARE CONFIDENTIAL AND COPYRIGHT PROPERTY OF THE HARWIN GROUP AND MUST NOT BE DISCLOSED, LOANED, COPIED OR USED FOR MANUFACTURING, TENDERING OR FOR ANY OTHER PURPOSE WITHOUT THEIR WRITTEN PERMISSION.

TOLERANCES

X. = ±1mm
X.X = ±0.50mm
X.XX = ±0.10mm
X.XXX = ±0.01mm
ANGLES = ±5°
UNLESS STATED

MATERIAL:

SEE ABOVE

FINISH:

SEE ABOVE

S/AREA:

mm²

TITLE: JACKSCREW DATAMATE DIL CRIMP (LARGE BORE) FEMALE ASSY WITH CABLE HOOD KIT

DRAWING NUMBER:

M80-941XXXX

SHT
2 OF 2