

Silicon NPN Power Transistors

2SC3949

**DESCRIPTION**

- With TO-3PML package
- High voltage ,high speed

**APPLICATIONS**

- For TV horizontal output and power switching applications

**PINNING**

PIN	DESCRIPTION
1	Base
2	Collector
3	Emitter

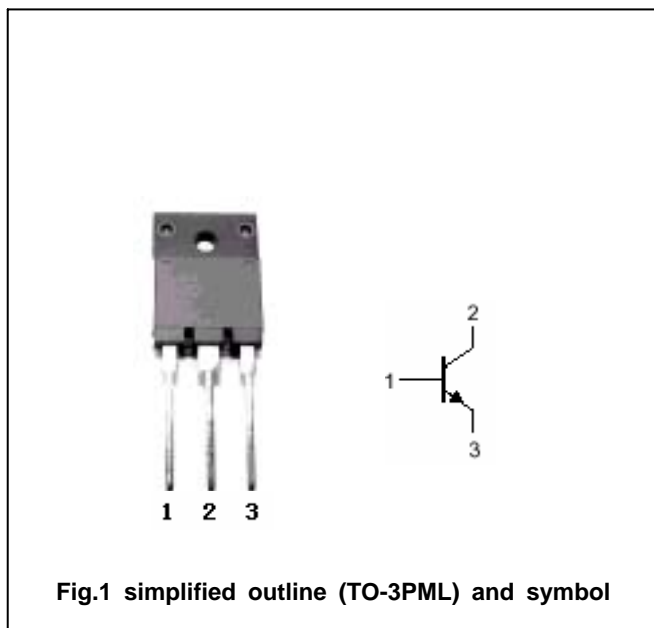

Fig.1 simplified outline (TO-3PML) and symbol

**Absolute maximum ratings (Ta=25 )**

SYMBOL	PARAMETER	CONDITIONS	MAX	UNIT
$V_{CBO}$	Collector-base voltage	Open emitter	850	V
$V_{CEO}$	Collector-emitter voltage	Open base	500	V
$V_{EBO}$	Emitter-base voltage	Open collector	7	V
$I_C$	Collector current		15	A
$P_C$	Collector dissipation	$T_C=25$	80	W
$T_j$	Junction temperature		150	
$T_{stg}$	Storage temperature		-55~150	

## Silicon NPN Power Transistors

## 2SC3949

## CHARACTERISTICS

T<sub>j</sub>=25 unless otherwise specified

SYMBOL	PARAMETER	CONDITIONS	MIN	TYP.	MAX	UNIT
V <sub>(BR)CEO</sub>	Collector-emitter breakdown voltage	I <sub>C</sub> =10mA ; R <sub>BE</sub> =	500			V
V <sub>(BR)CBO</sub>	Collector-base breakdown voltage	I <sub>C</sub> =1mA ; I <sub>E</sub> =0	850			V
V <sub>(BR)EBO</sub>	Emitter-base breakdown voltage	I <sub>E</sub> =1mA ; I <sub>C</sub> =0	7			V
V <sub>CEsat</sub>	Collector-emitter saturation voltage	I <sub>C</sub> =10A ; I <sub>B</sub> =2A			1.0	V
V <sub>BEsat</sub>	Base-emitter saturation voltage	I <sub>C</sub> =10A ; I <sub>B</sub> =2A			1.5	V
I <sub>CBO</sub>	Collector cut-off current	V <sub>CE</sub> =800V ; I <sub>E</sub> =0 T <sub>C</sub> =100			0.1 1.0	mA
I <sub>EBO</sub>	Emitter cut-off current	V <sub>EB</sub> =6V ; I <sub>C</sub> =0			0.1	mA
h <sub>FE</sub>	DC current gain	I <sub>C</sub> =10A ; V <sub>CE</sub> =5V	10		30	
f <sub>T</sub>	Transition frequency	I <sub>C</sub> =2A ; V <sub>CE</sub> =10V		20		MHz
C <sub>OB</sub>	Output capacitance	I <sub>E</sub> =0 ; V <sub>CB</sub> =10V ; f=1MHz		260		pF

Silicon NPN Power Transistors

2SC3949

PACKAGE OUTLINE

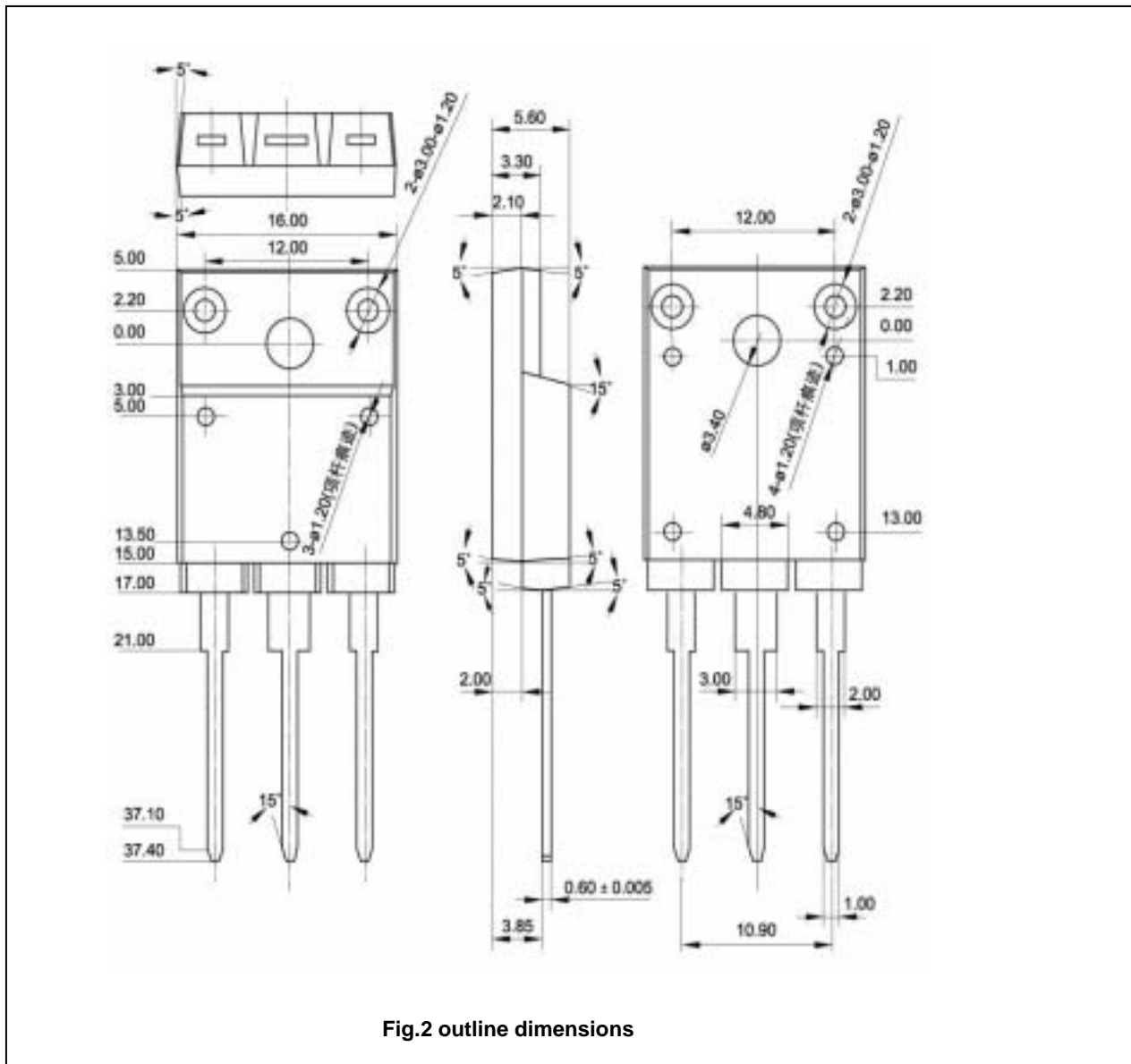

Fig.2 outline dimensions