



>5 B; GI '7 <5 B; >5 B; '9 @7 HF CB=7 G'H97 <BC @; M7 C'Z @B'

HC!&) %' @D`Ugh]W9 bWUdgi `UH`HfUbg]ghc fg`

'75+) ' TRANSISTOR (PNP)

: 95HI F9G`

- Power Dissipation

A5L=AI A`F5HB; G`fhU1&) °C`i b`Ygg`cH Yfk JgY`bcH`YXL`

Gna Vc`	DUFUa YHf`	JUi Y`	I b]h`
J76C`	Collector-Base Voltage	-40	V
J79C`	Collector-Emitter Voltage	-30	V
J96C`	Emitter-Base Voltage	-5	V
7`	Collector Current -Continuous	-2	A
D7`	Collector power dissipation	1.2	W
H`	Junction Temperature	150	°C
H _{gft} `	Storage Temperature	-55-150	°C

HC!&) %' @

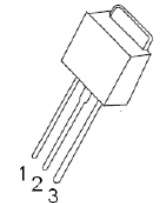

1.BASE
2.COLLECTOR
3.EMITTER

9 @7 HF =5 @ `7 <5 F5 7 H9F =GH7 G`fhU1&) °C`i b`Ygg`cH Yfk JgY`gdYWZ`YXL`

..... DUFUa YHf`	Gna Vc`	.. H`Ygh` .. W`bX]H`c`bg`	A]b`	Hmf`	`AU	`I b]h`
7c`Y`W`cf!VUgY`VfYU_Xck b`j`c`H] Y`	V _{(BR)CBO}	I _C =-100μA, I _E =0	-40			V
7c`Y`W`cf!Ya]H`Yf`VfYU_Xck b`j`c`H] Y`	V _{(BR)CEO}	I _C =-10mA, I _B =0	-30			V
9a]H`Yf!VUgY`VfYU_Xck b`j`c`H] Y`	V _{(BR)EBO}	I _E =-1mA, I _C =0	-5			V
7c`Y`W`cf`W`HcZZW`ffYbh`	I _{CBO}	V _{CE} =-40V, I _E =0			-0.1	μA
9a]H`Yf`W`HcZZW`ffYbh`	I _{EBO}	V _{EB} =-5V, I _C =0			-0.1	μA
87`W`ffYbh] U]b`	h _{FE}	V _{CE} =-2V, I _C =-500mA	100		400	
7c`Y`W`cf!Ya]H`Yf`gU] fU]cb`j`c`H] Y`	V _{CE(sat)}	I _C =-2A, I _B =-200mA			-0.8	V
	V _{CE(sat)}	I _C =-1.5A, I _B =-30mA			-2	V
HfUbg]H`cb`Z`Ye] YbW`ri	f _T	V _{CE} =-5V, I _C =-500mA		120		MHz
7c`Y`W`cf`ci`hdi`h`W`UdU`W`U`b`W`	C _{ob}	V _{CB} =-10V, I _E =0, f=1MHz		13		pF

'7 @GG= =5HCB`C: ` \ :9`

FUb`	O	Y	G
FUb] Y`	100-200	160-320	200-400

TO-251-3L Package Outline Dimensions

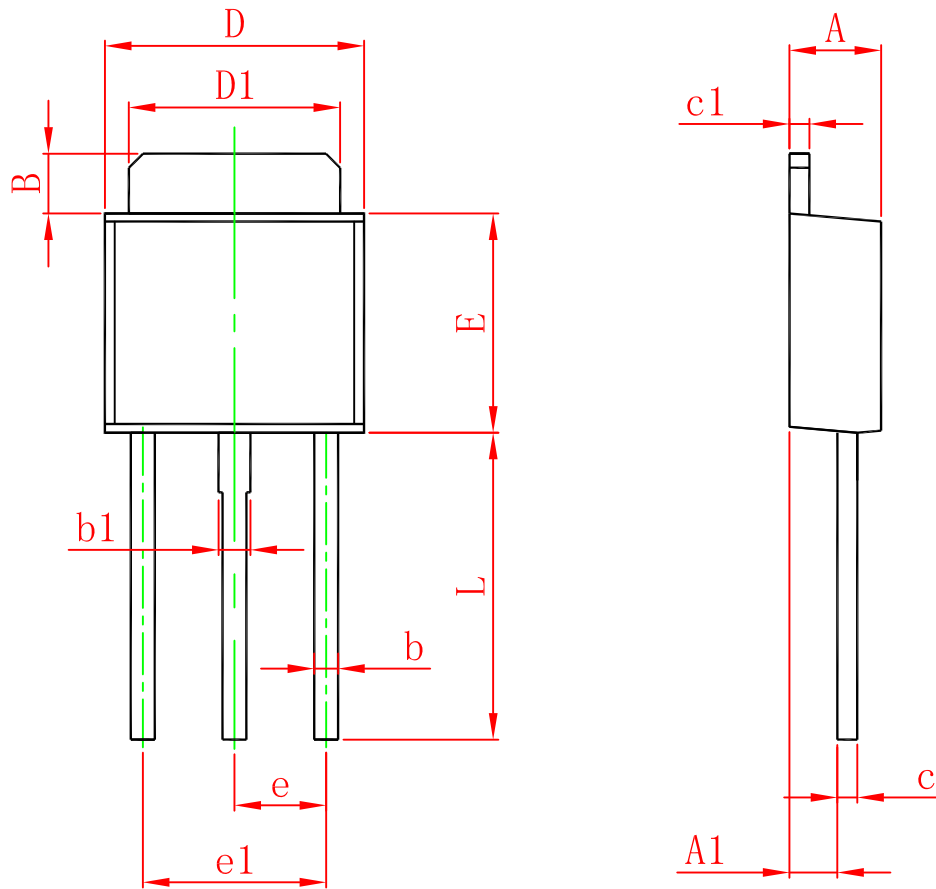

Symbol	Dimensions In Millimeters		Dimensions In Inches	
	Min.	Max.	Min.	Max.
A	2.200	2.400	0.087	0.094
A1	1.050	1.350	0.042	0.054
B	1.350	1.650	0.053	0.065
b	0.500	0.700	0.020	0.028
b1	0.700	0.900	0.028	0.035
c	0.430	0.580	0.017	0.023
c1	0.430	0.580	0.017	0.023
D	6.350	6.650	0.250	0.262
D1	5.200	5.400	0.205	0.213
E	5.400	5.700	0.213	0.224
e	2.300 TYP.		0.091 TYP.	
e1	4.500	4.700	0.177	0.185
L	7.500	7.900	0.295	0.311