

$I_{PN} = 40...1500A$ $V_{OUT} = \pm 4 V$

Features

- ◆ Hall effect measuring principle
- ◆ Galvanic isolation between primary and secondary circuit
- ◆ Isolation voltage 3000 V
- ◆ Low power consumption
- ◆ Extended measuring range (3 *IPN)
- ◆ Insulated plastic case recognized according to UL 94-V0

Advantages

- ◆ Easy installation
- ◆ Small size and space saving
- ◆ Only one design for wide current ratings range
- ◆ High immunity to external interference

Industrial applications

- ◆ DC motor drives
- ◆ Switched Mode Power Supplies(SMPS)
- ◆ AC variable speed drives
- ◆ Uninterruptible Power Supplies(UPS)
- ◆ Battery supplied applications
- ◆ Power supplies for welding applications

TYPES OF PRODUCTS		
Type	Primary nominal current r. m. s I_{PN} (A)	Primary current measuring range I_P (A)
SIOY3S400V2	400	±1200
SIOY3S500V2	500	±1500
SIOY3S600V2	600	±1800
SIOY3S800V2	800	±2400
SIOY3S1000V2	1000	±2500
SIOY3S1200V2	1200	±2500
SIOY3S1500V2	1500	±2500

General Description

For the electronic measurement of currents : DC, AC, pulsed, mixed, with a galvanic isolation between the primary circuit and the secondary circuit.

Parameters Table

PARAMETERS	SYMBOL	UNIT	VALUE	CONDITIONS
Electrical data				
Supply voltage($\pm 5\%$) ⁽¹⁾	V_C	V	± 15	
Current consumption	I_C	mA	± 15	
Output voltage	V_{out}	V	$\pm 4V$	@ $\pm I_{PN}$, $R_L = 10\text{ k}\Omega$, $T_A = 25^\circ\text{C}$
Isolation resistance	R_{IS}	$M\Omega$	>1000	@ 500 VDC
Output internal resistance	R_{OUT}	Ω	100	
Load resistance ⁽²⁾	R_L	$K\Omega$	>10	
Accuracy - Dynamic performance data				
Linearity ⁽³⁾ ($0 \dots \pm I_{PN}$)	ϵ_L	% of I_{PN}	$<\pm 1$	
Accuracy	X	% of I_{PN}	$<\pm 1$	@ I_{PN} , $T_A = 25^\circ\text{C}$ (excluding offset)
Electrical offset voltage	V_{OE}	mV	$<\pm 20$	@ $T_A = 25^\circ\text{C}$
Hysteresis offset voltage	V_{OH}	mV	$<\pm 10$	@ $I_P = 0$ after an excursion of $1 * I_{PN}$
Temperature coefficient of V_{OE}	TCV_{OE}	mV/K	<1	
Temperature coefficient of V_{OUT}	TCV_{OUT}	%/K	$<\pm 0.1$	
Response time	t_r	μs	<5	@ 90% of I_{PN} step
Frequency bandwidth ⁽⁴⁾	BW	kHz	DC~25	@ -3dB
General data				
Ambient operating temperature	T_A	$^\circ\text{C}$	-40 ~ +85	
Ambient storage temperature	T_S	$^\circ\text{C}$	-40 ~ +105	
Mass	m	g	300	
Isolation characteristics				
Rated isolation voltage rms	V_b	V	1000	
Rms voltage for AC isolation test	V_d	KV	3	50 Hz, 1 min
Creepage distance	dC_p	mm	>11	
Clearance distance	dC_l	mm	>11	
Comparative Tracking Index	CTI		275	Group IIIa

Notes:

- 1) Operating at $\pm 12V \leq V_C < \pm 15V$ will reduce the measuring range.
- 2) If the customer uses $10K\Omega$ of the load resistor, the primary current has to be limited as the nominal.
- 3) Linearity data exclude the electrical offset.
- 4) Please refer to derating curves in the technical file to avoid excessive core heating at high frequency.

Dimensions SIOY3SV2 (in mm. 1 mm = 0.0394 inch)

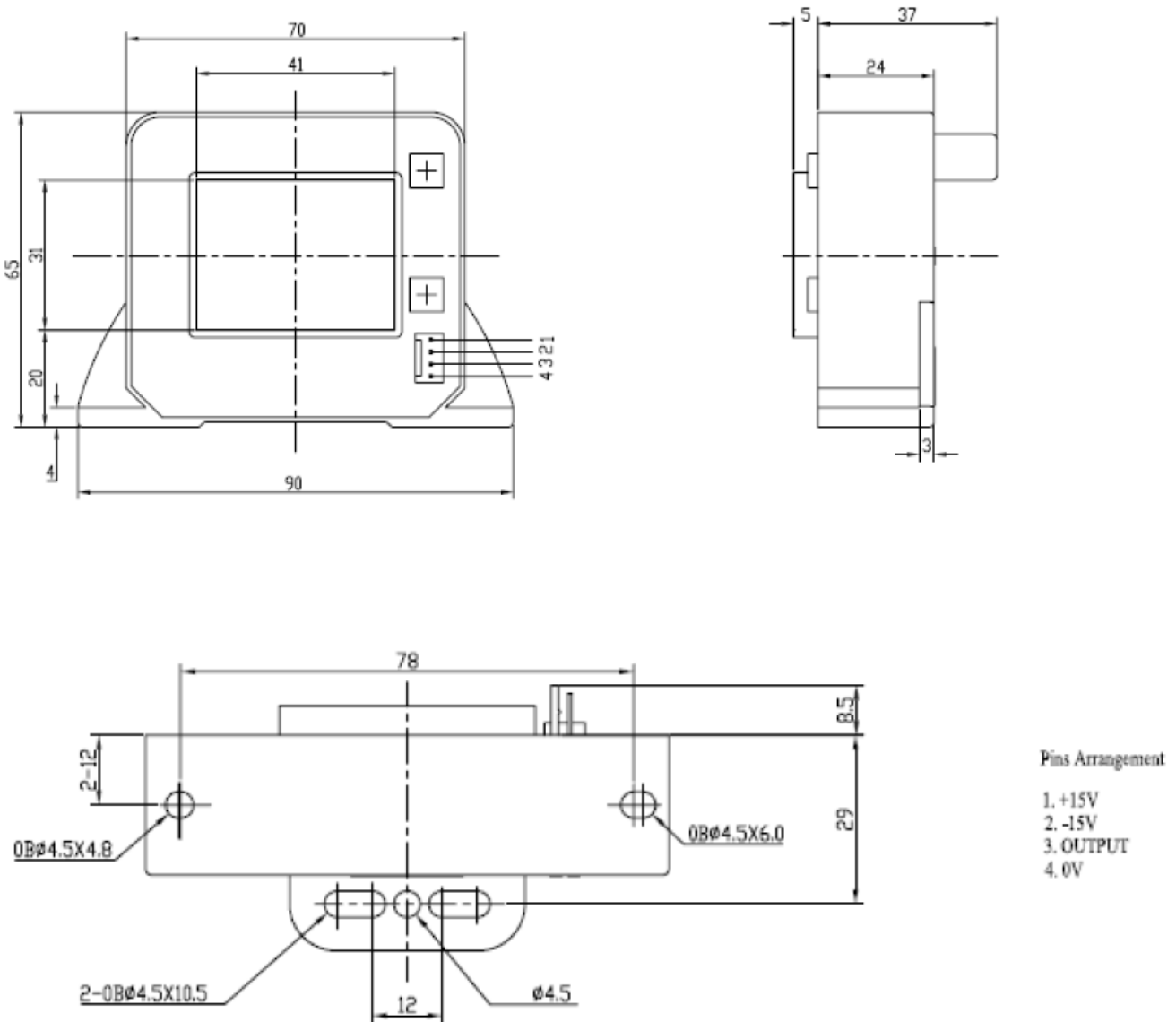

Instructions of use

- 1) When the test current passes through the sensors you can get the size of the output voltage.(Warning: wrong connection may lead to sensors damage)
- 2) Based on user needs, the sensors output range can be appropriately regulated.
- 3) According to user needs, different rated input currents and output voltages of the sensors can be customized.

RESTRICTIONS ON PRODUCT USE

The information contained herein is subject to change without notice.

SEC ELECTRONICS INC. (for short SEC) exerts the greatest possible effort to ensure high quality and reliability. Nevertheless, semiconductor devices in general can malfunction or fail due to their inherent electrical sensitivity and vulnerability to physical stress. It is the responsibility of the buyer, when utilizing SEC products, to comply with the standards of safety in making a safe design for the entire system, including redundancy, fire-prevention measures, and malfunction prevention, to prevent any accidents, fires, or community damage that may ensue. In developing your designs, please ensure that SEC products are used within specified operating ranges as set forth in the most recent SEC products specifications.

The SEC products listed in this document are intended for usage in general electronics applications (computer, personal equipment, office equipment, measuring equipment, industrial robotics, domestic appliances, etc.). These SEC products are neither intended nor warranted for usage in equipment that requires extraordinarily high quality and/or reliability or a malfunction or failure of which may cause loss of human life or bodily injury (“Unintended Usage”). Unintended Usage include atomic energy control instruments, airplane or spaceship instruments, transportation instruments, traffic signal instruments, combustion control instruments, medical instruments, all types of safety devices, etc.. Unintended Usage of SEC products listed in this document shall be made at the customer’s own risk.