

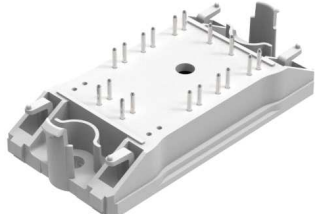
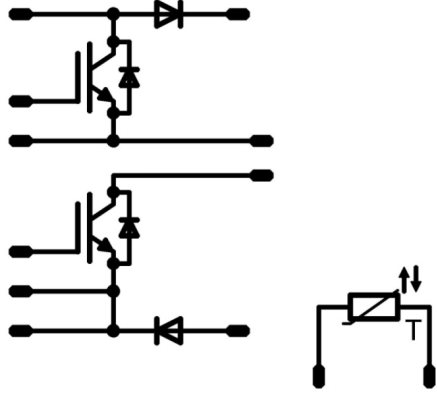

Vincotech

<i>flow</i> BOOST 0 symmetric	650 V / 75 A
<div style="background-color: #eee; padding: 2px; margin-bottom: 5px;">Features</div> <ul style="list-style-type: none"> High efficiency symmetric boost Ultra high switching frequency Clip-In PCB mounting Low Inductance Layout 	<div style="background-color: #eee; padding: 2px; margin-bottom: 5px;">flow 0 12mm housing</div> 
<div style="background-color: #eee; padding: 2px; margin-bottom: 5px;">Target applications</div> <ul style="list-style-type: none"> Solar inverters UPS Power supplies 	<div style="background-color: #eee; padding: 2px; margin-bottom: 5px;">Schematic</div> 
<div style="background-color: #eee; padding: 2px; margin-bottom: 5px;">Types</div> <ul style="list-style-type: none"> 10-FZ07NBA075SM-P916L58 	

Maximum Ratings

$T_j = 25\text{ °C}$, unless otherwise specified

Parameter	Symbol	Condition	Value	Unit
Boost Switch				
Collector-emitter voltage	V_{CES}		650	V
Collector current	I_C	$T_j = T_{jmax}$ $T_s = 80\text{ °C}$	57	A
Repetitive peak collector current	I_{CRM}	t_p limited by T_{jmax}	225	A
Total power dissipation	P_{tot}	$T_j = T_{jmax}$ $T_s = 80\text{ °C}$	97	W
Gate-emitter voltage	V_{GES}		±20	V
Maximum Junction Temperature	T_{jmax}		175	°C



Vincotech

Maximum Ratings

$T_j = 25\text{ °C}$, unless otherwise specified

Parameter	Symbol	Condition	Value	Unit
Boost Diode				
Peak Repetitive Reverse Voltage	V_{RRM}		650	V
Continuous (direct) forward current	I_F	$T_j = T_{jmax}$ $T_s = 80\text{ °C}$	59	A
Repetitive peak forward current	I_{FRM}		150	A
Total power dissipation	P_{tot}	$T_j = T_{jmax}$ $T_s = 80\text{ °C}$	78	W
Maximum Junction Temperature	T_{jmax}		175	°C

Boost Inverse Diode

Peak Repetitive Reverse Voltage	V_{RRM}		650	V
Continuous (direct) forward current	I_F	$T_j = T_{jmax}$ $T_s = 80\text{ °C}$	36	A
Repetitive peak forward current	I_{FRM}		60	A
Total power dissipation	P_{tot}	$T_j = T_{jmax}$ $T_s = 80\text{ °C}$	61	W
Maximum Junction Temperature	T_{jmax}		175	°C

Module Properties

Thermal Properties

Storage temperature	T_{stg}		-40...+125	°C
Operation temperature under switching condition	T_{jop}		-40...+($T_{jmax} - 25$)	°C

Isolation Properties

Isolation voltage	V_{isol}	DC Voltage $t_p = 2\text{ s}$	4000	V
Creepage distance			min. 12,7	mm
Clearance			9,53	mm
Comparative Tracking Index	CTI		> 200	



Vincotech

Characteristic Values

Parameter	Symbol	Conditions					Value			Unit
		V_{GE} [V] V_{GS} [V]	V_{CE} [V] V_{GS} [V] V_r [V]	I_C [A] I_D [A] I_F [A]	T_j [°C]	Min	Typ	Max		

Boost Switch

Static

Gate-emitter threshold voltage	$V_{GE(th)}$	$V_{GE} = V_{CE}$			0,00075	25	3,3	4	4,7	V
Collector-emitter saturation voltage	V_{CEsat}		15		75	25 125 150		1,67 1,84 1,89	2,22	V
Collector-emitter cut-off current	I_{CES}		0	650		25			40	μA
Gate-emitter leakage current	I_{GES}		20	0		25			120	nA
Internal gate resistance	r_g							none		Ω
Input capacitance	C_{ies}							4300		pF
Output capacitance	C_{oes}	$f = 1$ MHz	0	25		25		75		
Reverse transfer capacitance	C_{res}							16		
Gate charge	Q_g		15	520	75	25		166		nC

Thermal

Thermal resistance junction to sink	$R_{th(j-s)}$	phase-change material $\lambda = 3,4$ W/mK						0,98		K/W
-------------------------------------	---------------	---	--	--	--	--	--	------	--	-----

IGBT Switching

Turn-on delay time	$t_{d(on)}$					25 125 150		23 23 23		ns
Rise time	t_r	$R_{goff} = 4 \Omega$ $R_{gon} = 4 \Omega$				25 125 150		14 15 16		
Turn-off delay time	$t_{d(off)}$		15/0	350	75	25 125 150		116 131 135		
Fall time	t_f					25 125 150		4 8 10		
Turn-on energy (per pulse)	E_{on}	$Q_{rFWD} = 2,4 \mu C$ $Q_{rFWD} = 4,6 \mu C$ $Q_{rFWD} = 5,3 \mu C$				25 125 150		1,058 1,486 1,591		
Turn-off energy (per pulse)	E_{off}					25 125 150		0,277 0,481 0,527		



Vincotech

Characteristic Values

Parameter	Symbol	Conditions					Value			Unit
		V_{GE} [V] V_{GS} [V]	V_{CE} [V] V_{GS} [V] V_r [V]	I_C [A] I_D [A] I_F [A]	T_j [°C]	Min	Typ	Max		

Boost Diode

Static

Forward voltage	V_F				75	25 125 150		1,53 1,49 1,47	1,77	V
Reverse leakage current	I_r			650		25			3,8	μ A

Thermal

Thermal resistance junction to sink	$R_{th(j-s)}$	phase-change material $\lambda = 3,4$ W/mK						1,23		K/W
-------------------------------------	---------------	---	--	--	--	--	--	------	--	-----

FWD Switching

Peak recovery current	I_{RRM}					25 125 150		51 69 74		A
Reverse recovery time	t_{rr}					25 125 150		84 109 123		ns
Recovered charge	Q_r	$di/dt = 5120$ A/ μ s $di/dt = 4804$ A/ μ s $di/dt = 5399$ A/ μ s	15/0	350	75	25 125 150		2,383 4,616 5,343		μ C
Reverse recovered energy	E_{rec}					25 125 150		0,511 1,036 1,222		mWs
Peak rate of fall of recovery current	$(di_{rr}/dt)_{max}$					25 125 150		750 682 570		A/ μ s

Boost Inverse Diode

Static

Forward voltage	V_F				30	25 150		1,64 1,56	1,87	V
Reverse leakage current	I_r			650		25			0,36	μ A

Thermal

Thermal resistance junction to sink	$R_{th(j-s)}$	phase-change material $\lambda = 3,4$ W/mK						1,56		K/W
-------------------------------------	---------------	---	--	--	--	--	--	------	--	-----



Vincotech

Characteristic Values

Parameter	Symbol	Conditions					Value			Unit	
		V_{GE} [V]	V_{GS} [V]	V_{CE} [V]	V_{GS} [V]	V_T [V]	I_C [A]	I_D [A]	I_F [A]		T_j [°C]

Thermistor

Rated resistance	R					25		22		kΩ
Deviation of R100	$\Delta_{R/R}$	$R_{100} = 1484 \Omega$				100	-5		5	%
Power dissipation	P					25		5		mW
Power dissipation constant						25		1,5		mW/K
B-value	$B_{(25/50)}$	Tol. ±1%				25		3962		K
B-value	$B_{(25/100)}$	Tol. ±1%				25		4000		K
Vincotech NTC Reference									I	



Boost Switch Characteristics

Typical output characteristics IGBT

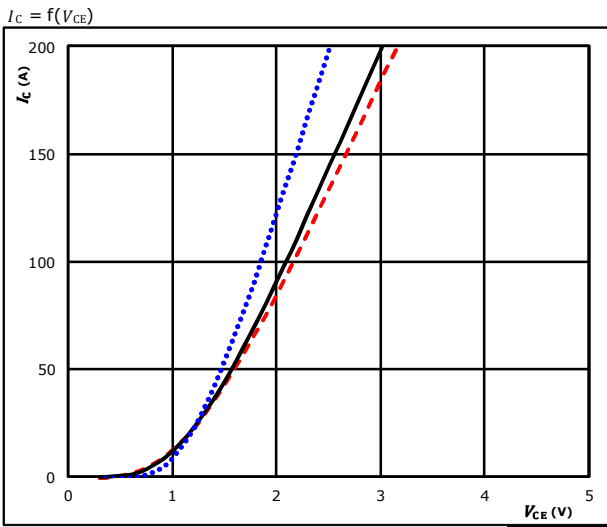

$t_p = 250 \mu s$
 $V_{GE} = 15 V$
 $T_j: 25 \text{ }^\circ C$ (dotted blue)
 $125 \text{ }^\circ C$ (solid black)
 $150 \text{ }^\circ C$ (dashed red)

Typical output characteristics IGBT

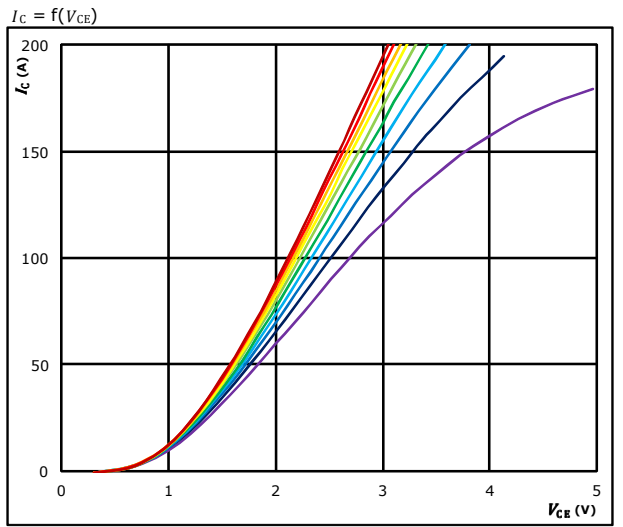

$t_p = 250 \mu s$
 $T_j = 150 \text{ }^\circ C$
 V_{GE} from 8 V to 17 V in steps of 1 V

Typical transfer characteristics IGBT

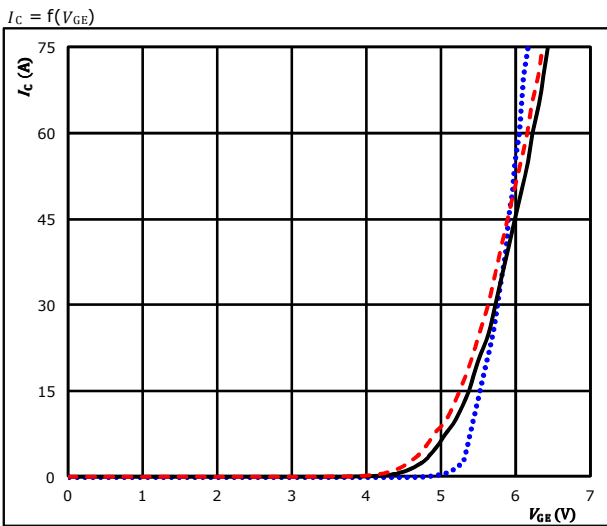

$t_p = 100 \mu s$
 $V_{CE} = 10 V$
 $T_j: 25 \text{ }^\circ C$ (dotted blue)
 $125 \text{ }^\circ C$ (solid black)
 $150 \text{ }^\circ C$ (dashed red)

Transient Thermal Impedance as function of Pulse duration IGBT

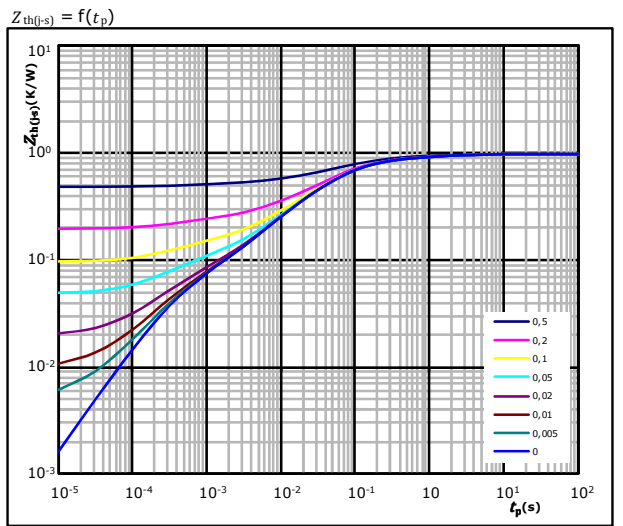

$D = t_p / T$
 $R_{th(j-s)} = 0,98 K/W$

IGBT thermal model values

R (K/W)	τ (s)
7,21E-02	2,25E+00
1,46E-01	3,32E-01
4,74E-01	6,42E-02
1,76E-01	1,63E-02
6,17E-02	3,99E-03
4,63E-02	3,57E-04



Boost Switch Characteristics

Gate voltage vs Gate charge IGBT

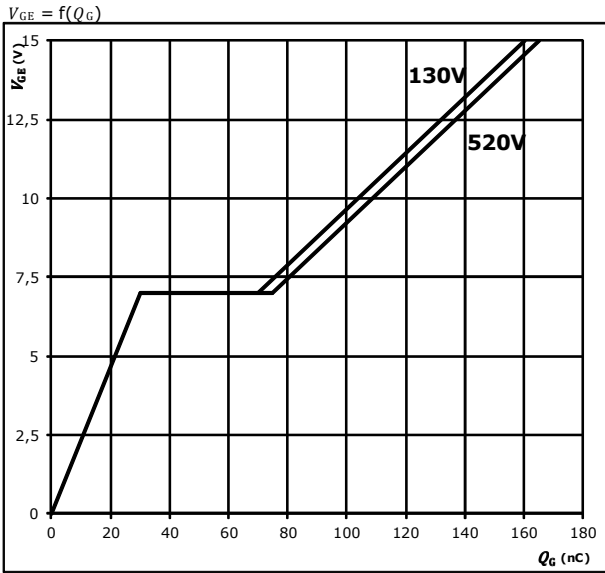

At
 $I_C = 75$ A

Safe operating area IGBT

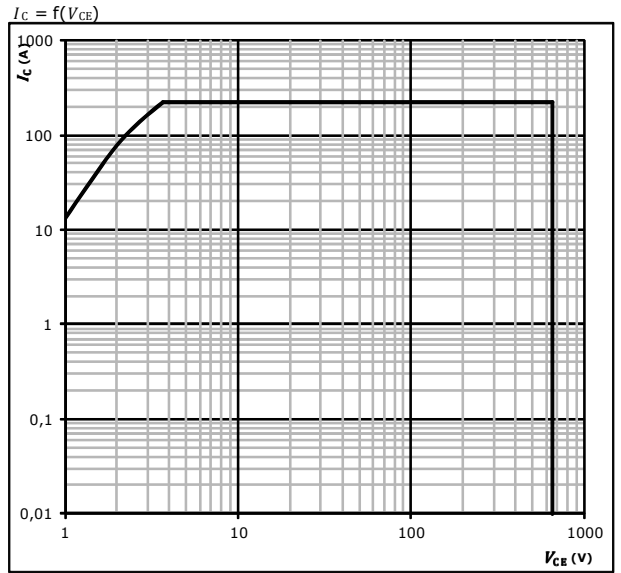

At
 $D =$ single pulse
 $T_h = 80$ °C
 $V_{GE} = \pm 15$ V
 $T_j = T_{jmax}$ °C



Vincotech

Boost Diode Characteristics

Typical forward characteristics FWD

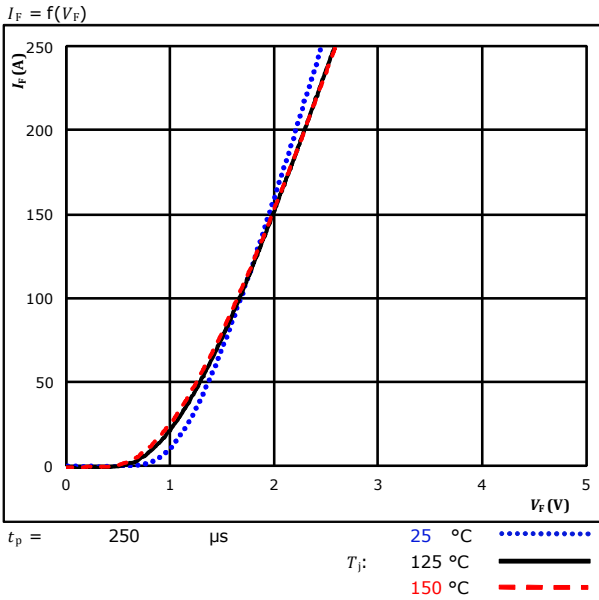

Transient thermal impedance as a function of pulse width FWD

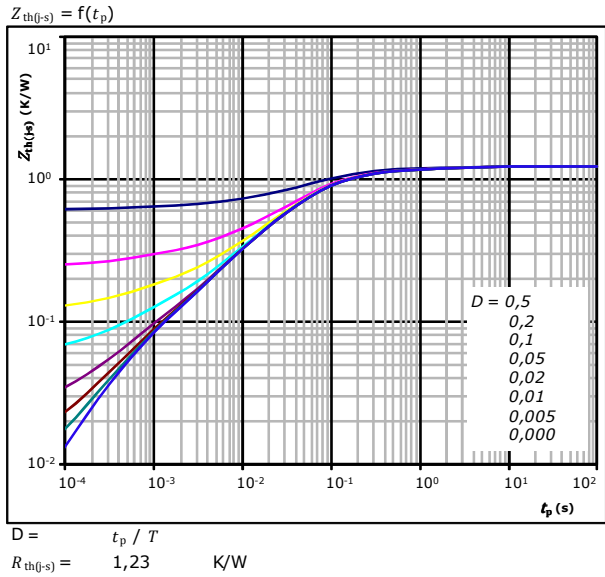

FWD thermal model values

R (K/W)	τ (s)
8,04E-02	2,68E+00
1,74E-01	2,85E-01
6,28E-01	6,23E-02
2,05E-01	1,65E-02
8,90E-02	4,15E-03
4,76E-02	4,96E-04



Boost Inverse Diode Characteristics

Typical forward characteristics FWD

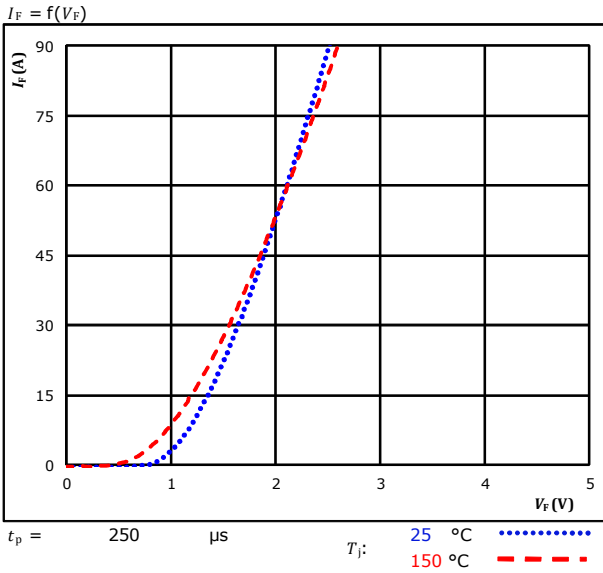

Transient thermal impedance as a function of pulse width FWD

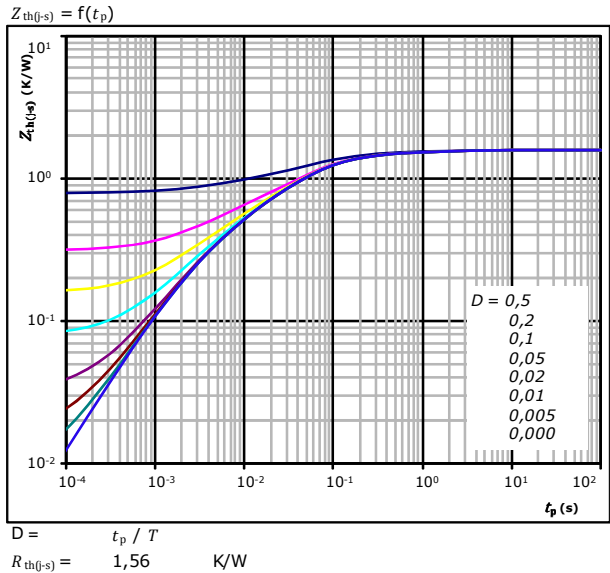

FWD thermal model values

R (K/W)	τ (s)
9,10E-02	2,00E+00
3,45E-01	1,68E-01
7,17E-01	4,13E-02
2,97E-01	7,43E-03
1,15E-01	1,80E-03

Thermistor Characteristics

Thermistor typical temperature characteristic

Typical NTC characteristic
as a function of temperature

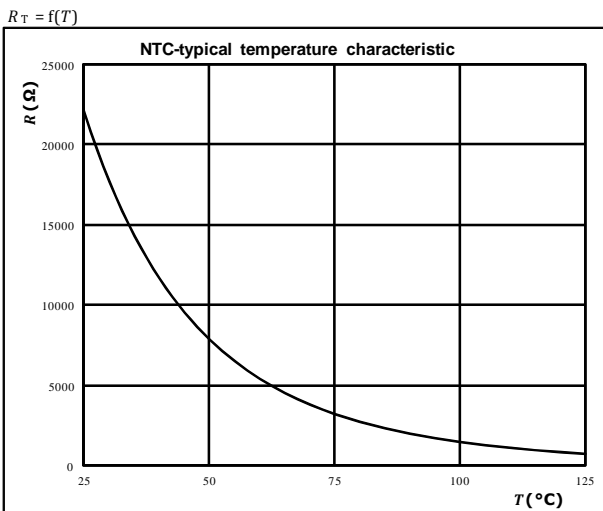



Boost Switching Characteristics

Figure 1. IGBT
Typical switching energy losses as a function of collector current

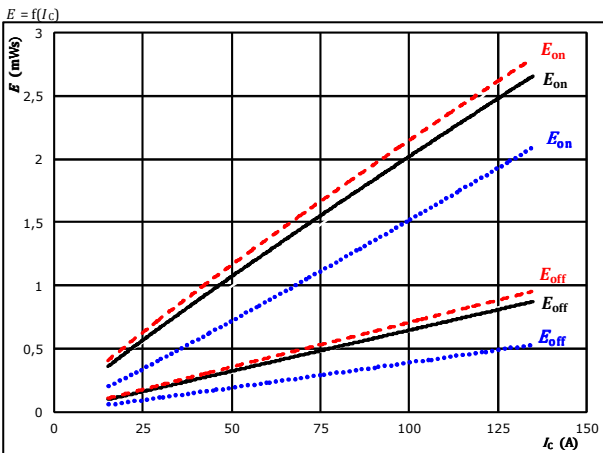

With an inductive load at
 $V_{CE} = 350$ V
 $V_{GE} = 15/0$ V
 $R_{gon} = 4$ Ω
 $R_{goff} = 4$ Ω
 T_j : 25 °C (dotted blue), 125 °C (solid black), 150 °C (dashed red)

Figure 2. IGBT
Typical switching energy losses as a function of gate resistor

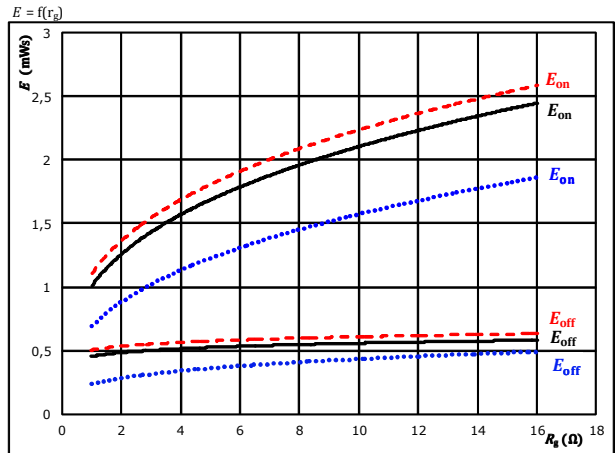

With an inductive load at
 $V_{CE} = 350$ V
 $V_{GE} = 15/0$ V
 $I_C = 75$ A
 T_j : 25 °C (dotted blue), 125 °C (solid black), 150 °C (dashed red)

Figure 3. FWD
Typical reverse recovered energy loss as a function of collector current

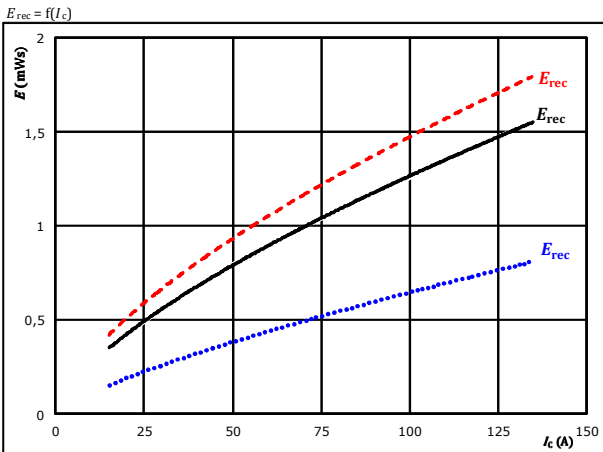

With an inductive load at
 $V_{CE} = 350$ V
 $V_{GE} = 15/0$ V
 $R_{gon} = 4$ Ω
 T_j : 25 °C (dotted blue), 125 °C (solid black), 150 °C (dashed red)

Figure 4. FWD
Typical reverse recovered energy loss as a function of gate resistor

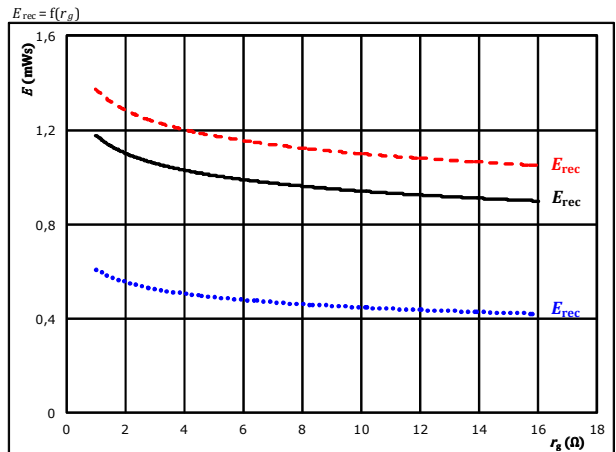

With an inductive load at
 $V_{CE} = 350$ V
 $V_{GE} = 15/0$ V
 $I_C = 75$ A
 T_j : 25 °C (dotted blue), 125 °C (solid black), 150 °C (dashed red)



Boost Switching Characteristics

Figure 5. IGBT

Typical switching times as a function of collector current

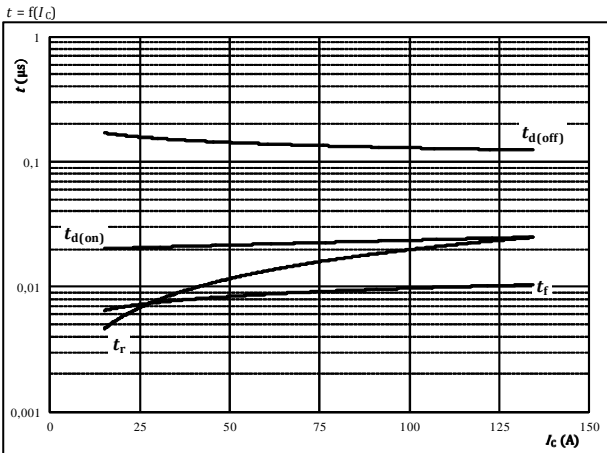

With an inductive load at

$T_j =$	150	°C
$V_{CE} =$	350	V
$V_{GE} =$	15/0	V
$R_{gon} =$	4	Ω
$R_{goff} =$	4	Ω

Figure 6. IGBT

Typical switching times as a function of gate resistor

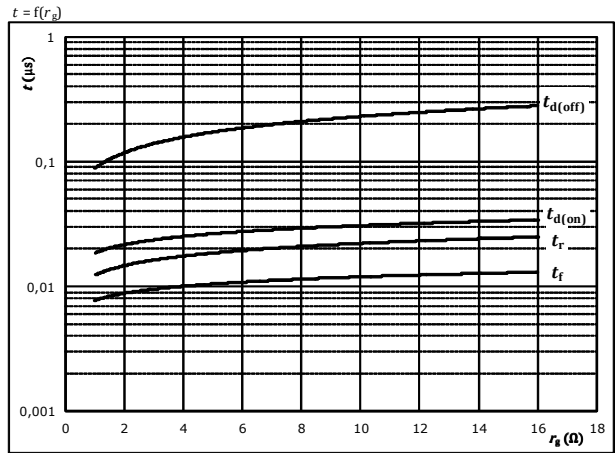

With an inductive load at

$T_j =$	150	°C
$V_{CE} =$	350	V
$V_{GE} =$	15/0	V
$I_C =$	75	A

Figure 7. FWD

Typical reverse recovery time as a function of collector current

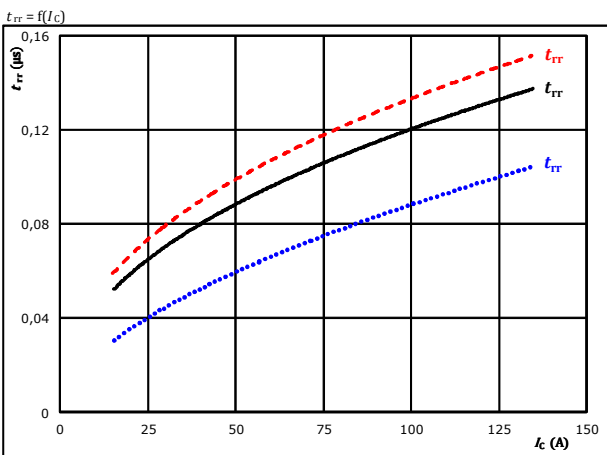

At	$V_{CE} =$	350	V	$T_j:$	25 °C
	$V_{GE} =$	15/0	V		125 °C	————
	$R_{gon} =$	4	Ω		150 °C	-----

Figure 8. FWD

Typical reverse recovery time as a function of IGBT turn on gate resistor

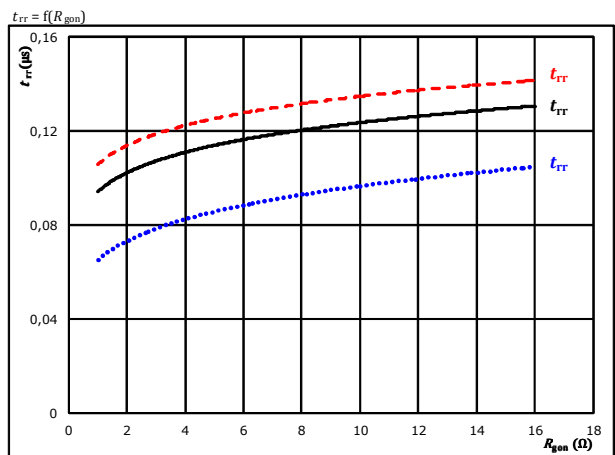

At	$V_{CE} =$	350	V	$T_j:$	25 °C
	$V_{GE} =$	15/0	V		125 °C	————
	$I_C =$	75	A		150 °C	-----



Boost Switching Characteristics

Figure 9. Typical recovered charge as a function of collector current FWD

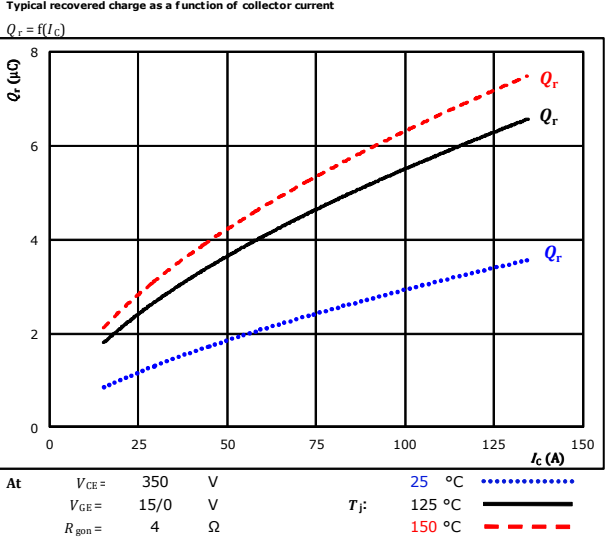

Figure 10. Typical recovered charge as a function of IGBT turn on gate resistor FWD

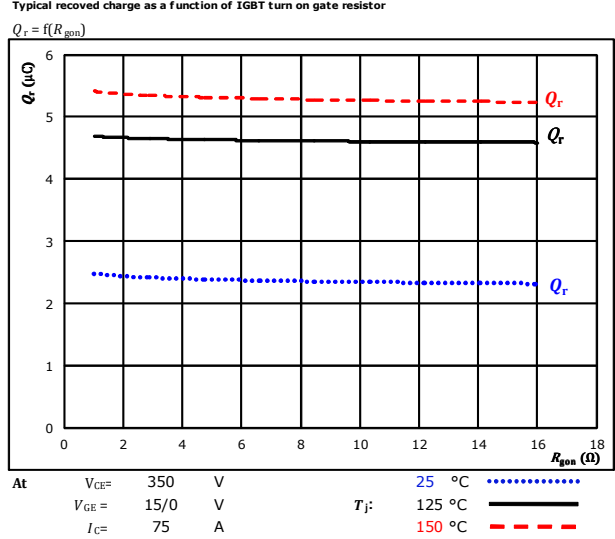

Figure 11. Typical peak reverse recovery current as a function of collector current FWD

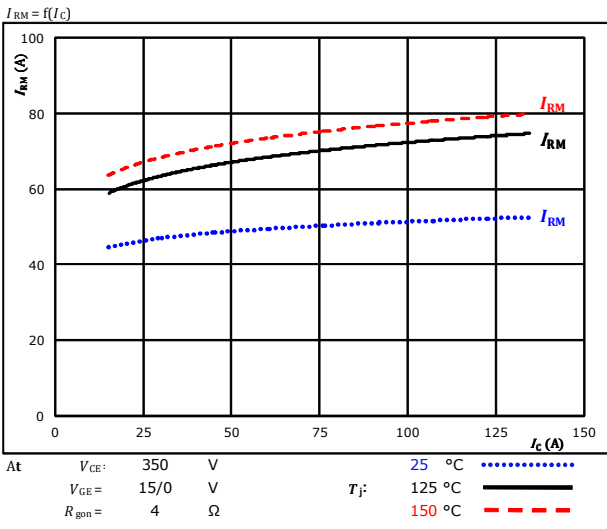
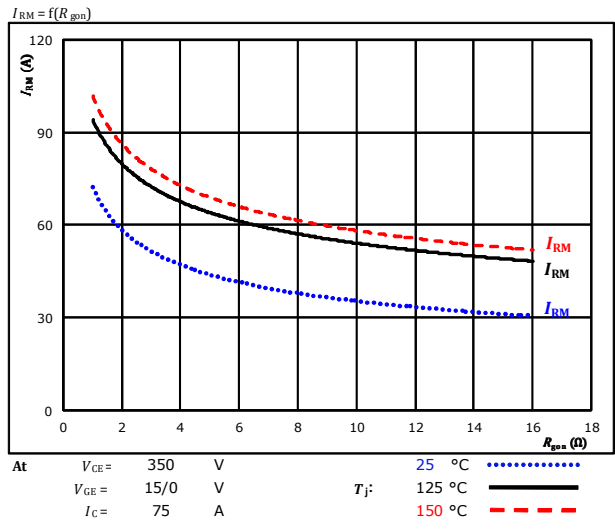

Figure 12. Typical peak reverse recovery current as a function of IGBT turn on gate resistor FWD





Boost Switching Characteristics

Figure 13. FWD
Typical rate of fall of forward and reverse recovery current as a function of collector current

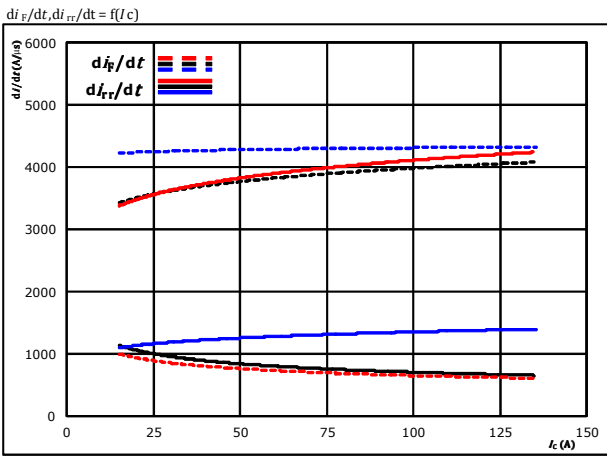

At $V_{CE} = 350$ V
 $V_{GE} = 15/0$ V
 $R_{gon} = 4$ Ω
 $T_j = 25$ °C
 125 °C
 150 °C

Figure 14. FWD
Typical rate of fall of forward and reverse recovery current as a function of IGBT turn on gate resistor

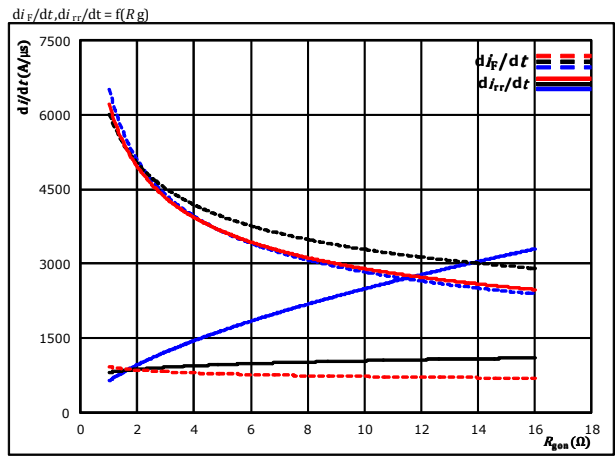

At $V_{CE} = 350$ V
 $V_{GE} = 15/0$ V
 $I_C = 75$ A
 $T_j = 25$ °C
 125 °C
 150 °C

Figure 15. IGBT
Reverse bias safe operating area

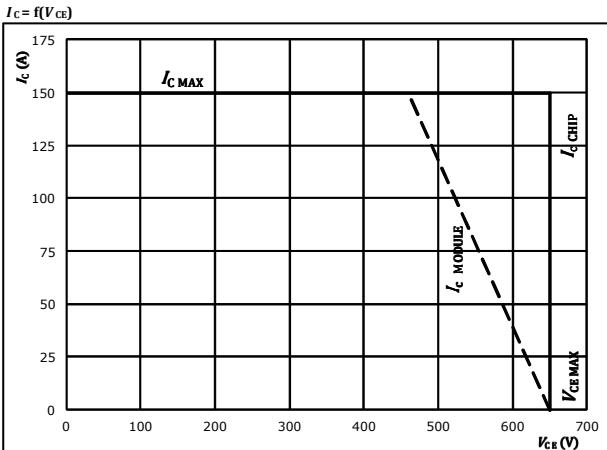

At $T_j = 175$ °C
 $R_{gon} = 4$ Ω
 $R_{goff} = 4$ Ω



Boost Switching Definitions

General conditions	
T_j	= 125 °C
R_{gon}	= 4 Ω
R_{goff}	= 4 Ω

Figure 1. IGBT
Turn-off Switching Waveforms & definition of t_{doff} , t_{Eoff} (t_{Eoff} = integrating time for Eoff)

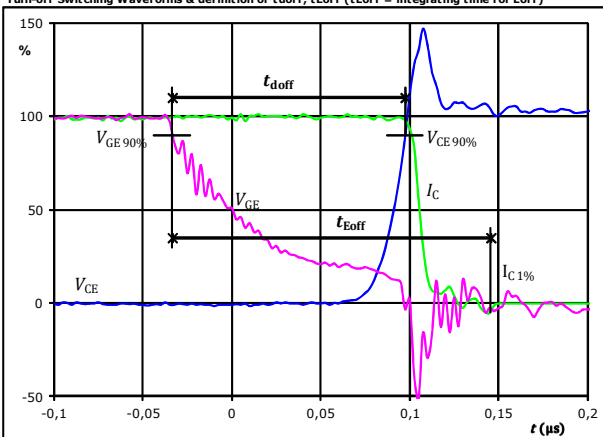

$V_{GE}(0\%) =$	0	V
$V_{GE}(100\%) =$	15	V
$V_C(100\%) =$	350	V
$I_C(100\%) =$	75	A
$t_{doff} =$	0,131	μs
$t_{Eoff} =$	0,179	μs

Figure 2. IGBT
Turn-on Switching Waveforms & definition of t_{don} , t_{Eon} (t_{Eon} = integrating time for Eon)

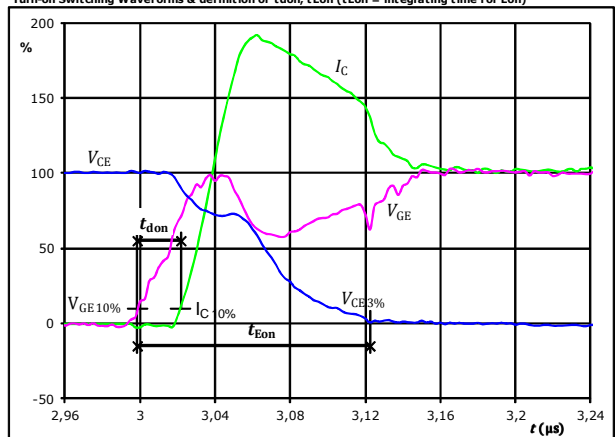

$V_{GE}(0\%) =$	0	V
$V_{GE}(100\%) =$	15	V
$V_C(100\%) =$	350	V
$I_C(100\%) =$	75	A
$t_{don} =$	0,023	μs
$t_{Eon} =$	0,124	μs

Figure 3. IGBT
Turn-off Switching Waveforms & definition of t_f

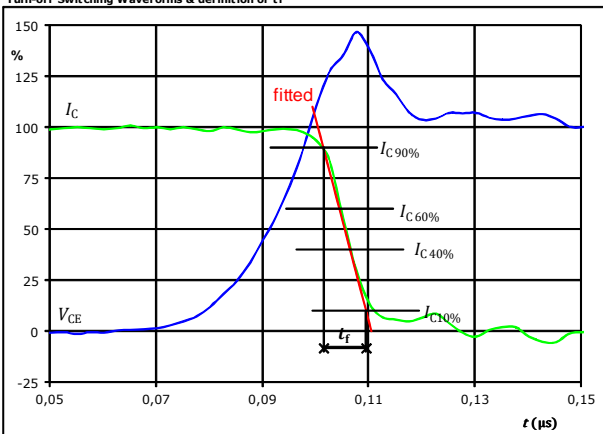

$V_C(100\%) =$	350	V
$I_C(100\%) =$	75	A
$t_f =$	0,008	μs

Figure 4. IGBT
Turn-on Switching Waveforms & definition of t_r

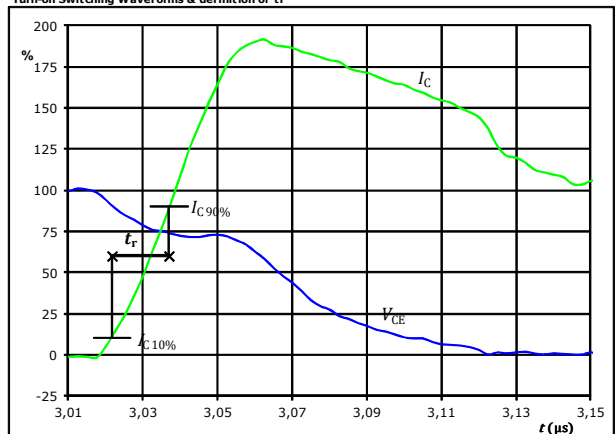

$V_C(100\%) =$	350	V
$I_C(100\%) =$	75	A
$t_r =$	0,015	μs



Vincotech

Boost Switching Definitions

Figure 5. IGBT

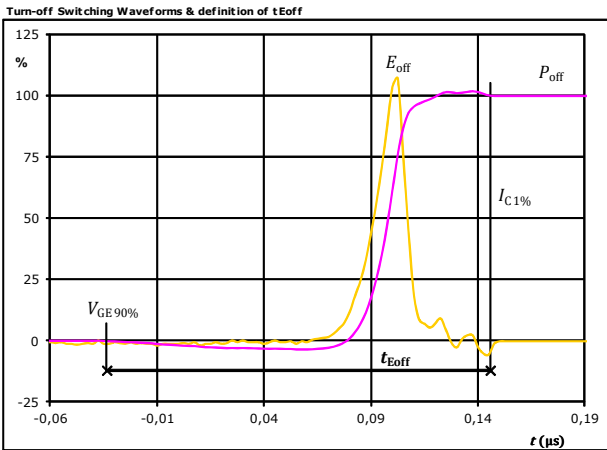

$P_{off}(100\%) =$	26,34	kW
$E_{off}(100\%) =$	0,48	mJ
$t_{Eoff} =$	0,18	μs

Figure 6. IGBT

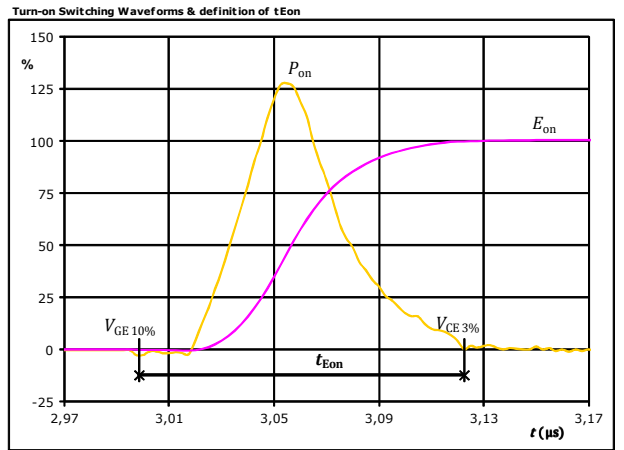

$P_{on}(100\%) =$	26,34	kW
$E_{on}(100\%) =$	1,49	mJ
$t_{Eon} =$	0,12	μs

Figure 7. FWD

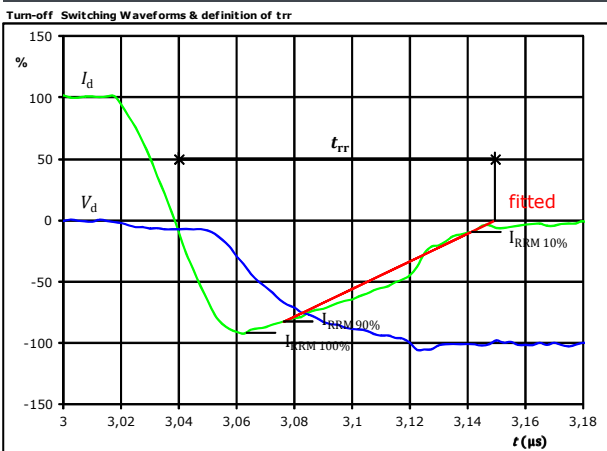

$V_d(100\%) =$	350	V
$I_d(100\%) =$	75	A
$I_{RRM}(100\%) =$	-69	A
$t_{rr} =$	0,109	μs



Boost Switching Definitions

Figure 8. FWD

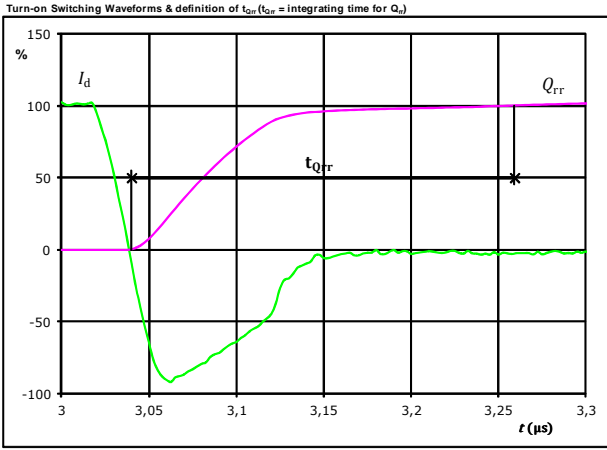

$I_d(100\%) =$	75	A
$Q_{rr}(100\%) =$	4,62	μC
$t_{Qrr} =$	0,22	μs

Figure 9. FWD

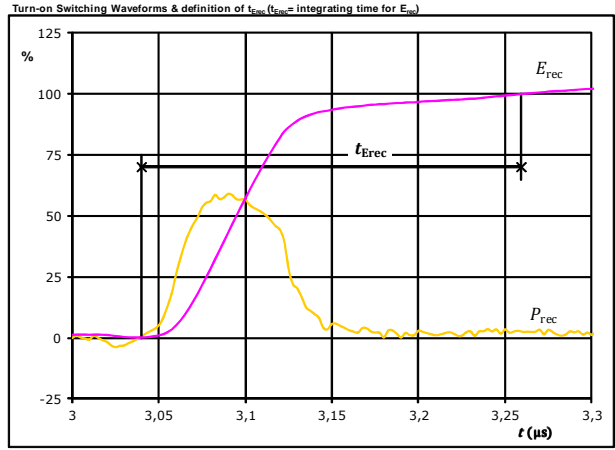

$P_{rec}(100\%) =$	26,34	kW
$E_{rec}(100\%) =$	1,04	mJ
$t_{Erec} =$	0,22	μs



Vincotech

Ordering Code & Marking								
Version			Ordering Code					
without thermal paste 12mm housing with solder pins			10-FZ07NBA075SM-P916L58					
NN-NNNNNNNNNNNNNN TTTTIVV WWYY UL Vinco LLLLL SSSS		Text	Name		Date code	UL & Vinco	Lot	Serial
			NN-NNNNNNNNNNNNNN-TTTTIVV		WWYY	UL Vinco	LLLLL	SSSS
		Datamatrix	Type&Ver	Lot number	Serial	Date code		
			TTTTTIVV	LLLLL	SSSS	WWYY		

Pin table			
Pin	X	Y	Function
1	33,6	0	G1
2	30,6	0	S1
3	23,65	0	+GND
4	20,65	0	+GND
5	14,9	0	+DC
6	11,9	0	+DC
7	Not assembled		
8	Not assembled		
9	0	7,8	+Boost
10	3	7,8	+Boost
11	0	14,8	-Boost
12	3	14,8	-Boost
13	Not assembled		
14	Not assembled		
15	11,9	22,6	-DC
16	14,9	22,6	-DC
17	20,65	22,6	-GND
18	23,65	22,6	-GND
19	30,6	22,6	S2
20	33,6	22,6	G2
21	33,6	14,55	NTC1
22	33,6	8,05	NTC2

Tolerance of pinpositions ±0,5mm at the end of pins
Dimension of coordinate axis is only offset without tolerance



Vincotech

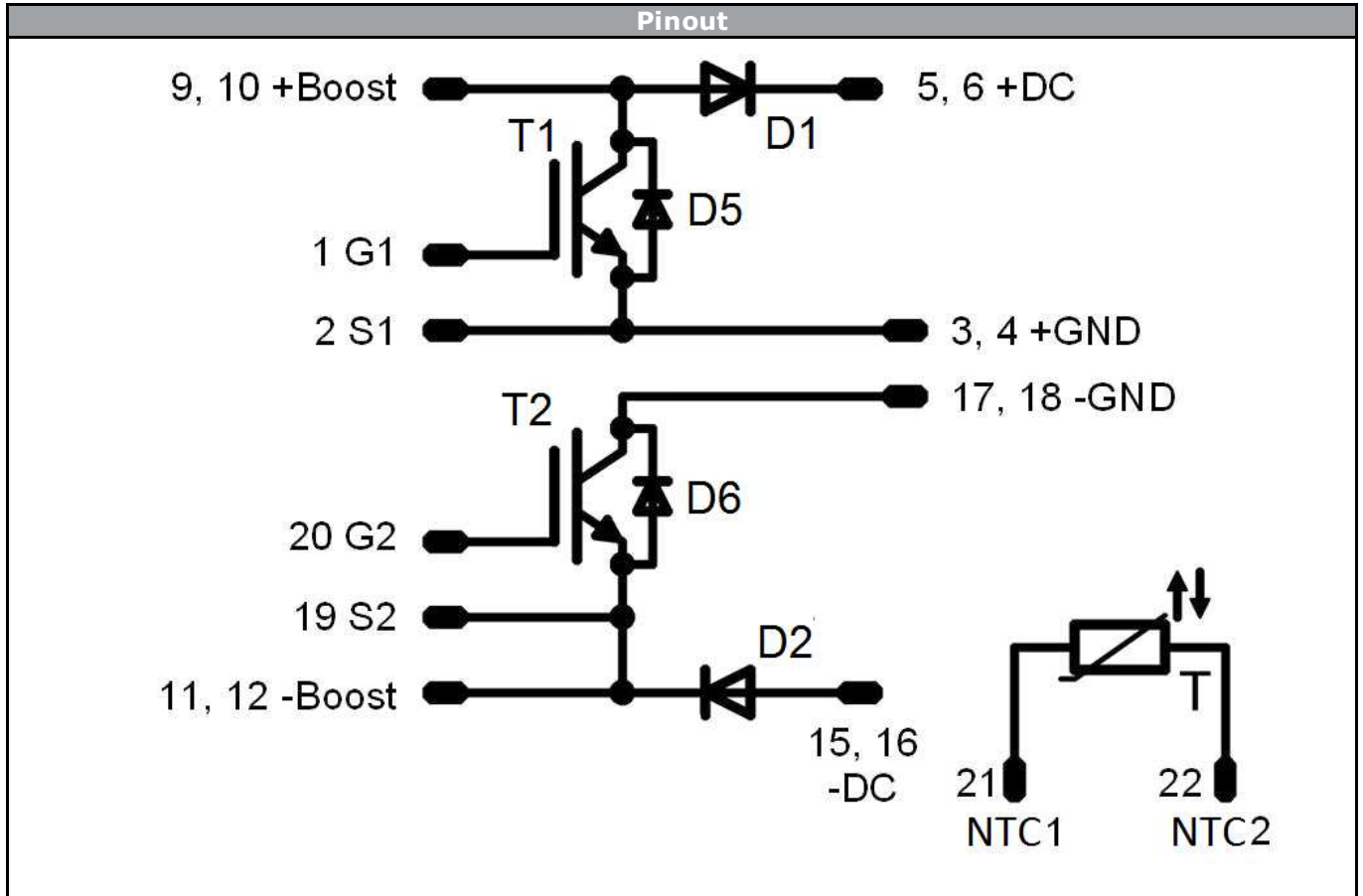

Identification					
ID	Component	Voltage	Current	Function	Comment
T1,T2	IGBT	650 V	75 A	Boost Switch	
D1,D2	FWD	650 V	75 A	Boost Diode	
D5,D6	FWD	650 V	30 A	Boost Inverse Diode	
T	NTC			Thermistor	



Vincotech

Packaging instruction					
Standard packaging quantity (SPQ)	135	>SPQ	Standard	<SPQ	Sample

Handling instruction	
Handling instructions for <i>flow</i> 0 packages see vincotech.com website.	

Package data	
Package data for <i>flow</i> 0 packages see vincotech.com website.	

Document No.:	Date:	Modification:	Pages
10-FZ07NBA075SM-P916L58-D1-14	22 Feb. 2016		

DISCLAIMER

The information, specifications, procedures, methods and recommendations herein (together "information") are presented by Vincotech to reader in good faith, are believed to be accurate and reliable, but may well be incomplete and/or not applicable to all conditions or situations that may exist or occur. Vincotech reserves the right to make any changes without further notice to any products to improve reliability, function or design. No representation, guarantee or warranty is made to reader as to the accuracy, reliability or completeness of said information or that the application or use of any of the same will avoid hazards, accidents, losses, damages or injury of any kind to persons or property or that the same will not infringe third parties rights or give desired results. It is reader's sole responsibility to test and determine the suitability of the information and the product for reader's intended use.

LIFE SUPPORT POLICY

Vincotech products are not authorised for use as critical components in life support devices or systems without the express written approval of Vincotech.

As used herein:

1. Life support devices or systems are devices or systems which, (a) are intended for surgical implant into the body, or (b) support or sustain life, or (c) whose failure to perform when properly used in accordance with instructions for use provided in labelling can be reasonably expected to result in significant injury to the user.
2. A critical component is any component of a life support device or system whose failure to perform can be reasonably expected to cause the failure of the life support device or system, or to affect its safety or effectiveness.