



Thin-Film Cascadable Amplifier 10 to 100 MHz

Technical Data

UTO/UTC 111 Series

Features

- **Frequency Range: 10 to 100 MHz**
- **Low Noise: 1.4 dB (Typ)**
- **Medium Power: 16.8 dBm (Typ)**
- **Temperature Compensated**

Applications

- **Low Frequency IF Stages**
- **Medical Instruments: Ultra-Sound, Magnetic Resonance**
- **High Efficiency or Battery Powered Systems**

Description

The 111 Series is a single-stage, high-gain silicon bipolar amplifier that incorporates thin-film technology. Low noise figure and high efficiency are the result of an output transformer coupling design. Active bias circuits provide temperature compensation and increased immunity to bias voltage variations. Blocking capacitors couple the RF through the amplifier, while a low VSWR is maintained through unique transformer designs. The 111 Series is available in either the TO-8 hermetic package or the connected TC-1A package.

Pin Configuration UTO—TO-8T

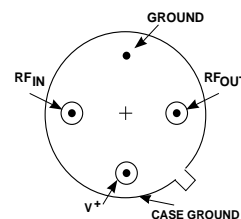

UTC—TC-1A

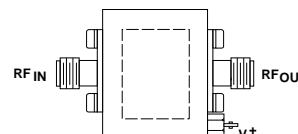

Schematic

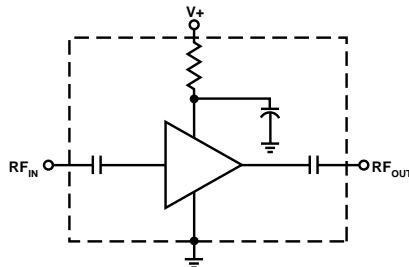

Maximum Ratings

Parameter	Maximum
DC Voltage	17 Volts
Continuous RF Input Power	+13 dBm
Operating Case Temperature	-55 to +125°C
Storage Temperature	-62 to +150°C
"R" Series Burn-In Temperature	+125°C

Thermal Characteristics¹

θ_{JC}	105°C/W
Active Transistor Power Dissipation	110 mW
Junction Temperature Above Case Temperature	12°C
MTBF (MIL-HDBK-217E, A_{UF} @ 90°C)	848,400 Hrs.

Weight: (typical) UTO — 2.1 grams; UTC — 21.5 grams

Electrical Specifications

(Measured in 50 Ω system @ +15 VDC nominal)

Symbol	Characteristic	Typical $T_C = 25^\circ\text{C}$	Guaranteed Specifications		Unit
			$T_C = 0 \text{ to } 50^\circ\text{C}$	$T_C = -55 \text{ to } +85^\circ\text{C}$	
BW	Frequency Range	10-100	10-100	10-100	MHz
GP	Small Signal Gain (Min.)	11.5	10.5	10.0	dB
—	Gain Flatness (Max.)	± 0.1	± 0.3	± 0.5	dB
NF	Noise Figure (Max.)	1.4	1.7	2.0	dB
P_{1dB}	Power Output @ +1 dB Comp. (Min.)	+16.8	+15.5	+15.5	dBm
—	Input VSWR (Max.)	1.4:1	2.0:1	2.0:1	—
—	Output VSWR (Max.)	1.3:1	2.0:1	2.0:1	—
IP_3	Two Tone 3rd Order Intercept Point	+33.0	+28.0	+28.0	dBm
IP_2	Two Tone 2nd Order Intercept Point	+47.0	—	—	dBm
HP_2	One Tone 2nd Harmonic Intercept Point	+53.0	—	—	dBm
I_D	DC Current	14	—	—	mA

Typical Performance Over Temperature (@ +15 VDC unless otherwise noted)

Key: +25°C ———
+85°C - - -
-55°C ———

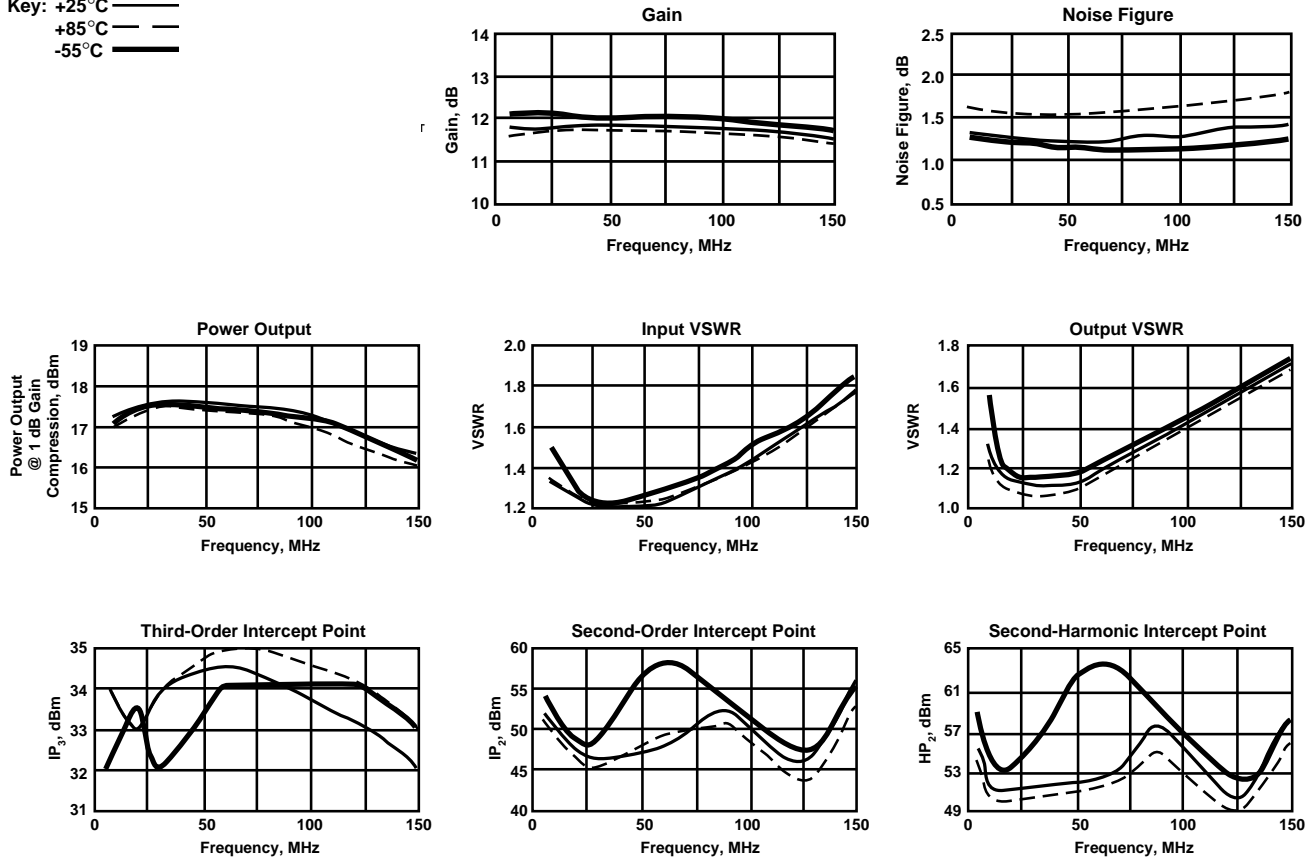

Automatic Network Analyzer Measurements (Typical production unit @ +25°C ambient)**Numerical Readings****Bias = 15.00 Volts**

FREQUENCY MHz	VSWR IN	GAIN dB	PHASE DEGREES	PHASE DEV	GROUP DELAY ns	VSWR OUT	ISOLATION dB
10.0	1.35	11.8	15.8	6.90	3.63	1.35	14.5
20.0	1.25	11.8	2.7	-1.12	3.63	1.15	14.6
30.0	1.20	11.8	-4.2	-2.93	1.91	1.13	14.6
40.0	1.22	11.9	-8.9	-2.57	1.31	1.13	14.6
50.0	1.2	11.9	-13.6	-2.20	1.31	1.17	14.6
60.0	1.27	11.9	-18.0	-1.53	1.21	1.22	14.6
70.0	1.30	11.9	-22.1	-.65	1.16	1.25	14.6
80.0	1.35	11.8	-26.2	.30	1.14	1.30	14.6
90.0	1.41	11.8	-30.2	1.35	1.12	1.35	14.7
100.0	1.47	11.8	-34.2	2.47	1.09	1.41	14.8
110.0	1.53	11.7	-38.1		1.09	1.47	14.8
120.0	1.56	11.7	-42.0		1.07	1.53	14.9
130.0	1.63	11.6	-45.8		1.07	1.60	15.0
140.0	1.70	11.6	-49.7		1.06	1.67	15.1
150.0	1.78	11.5	-53.5		1.07	1.74	15.2
160.0	1.86	11.4	-57.3		1.06	1.82	15.4
170.0	1.94	11.3	-61.1		1.05	1.90	15.5
180.0	2.03	11.2	-64.9		1.06	1.94	15.6
190.0	2.13	11.2	-68.7		1.06	2.03	15.8
200.0	2.17	11.1	-72.5		1.06	2.13	15.9
210.0	2.28	11.0	-76.4		1.06	2.23	16.1
220.0	2.39	10.9	-80.2		1.07	2.28	16.2
230.0	2.45	10.7	-84.1		1.07	2.39	16.4
240.0	2.57	10.6	-88.0		1.08	2.51	16.6
250.0	2.70	10.5	-91.9		1.09	2.57	16.8

LINEARIZATION RANGE: 10.0 to 150.0 MHz

S-Parameters**Bias = 15.00 Volts**

FREQUENCY MHz	S_{11}		S_{21}		S_{12}		S_{22}	
	Mag	Ang	dB	Ang	dB	Ang	Mag	Ang
10.0	.15	136.7	11.8	15.8	-14.5	15.5	.15	83.80
20.0	.11	160.1	11.8	2.7	-14.6	2.7	.07	49.21
30.0	.09	172.5	11.8	-4.2	-14.6	-4.2	.06	11.44
40.0	.10	-170.6	11.9	-8.9	-14.6	-8.9	.06	-29.34
50.0	.10	-160.7	11.9	-13.6	-14.6	-13.5	.08	-51.48
60.0	.12	-153.5	11.9	-18.0	-14.6	-17.8	.10	-67.04
70.0	.13	-149.0	11.9	-22.1	-14.6	-22.0	.11	-78.78
80.0	.15	-146.5	11.8	-26.2	-14.6	-26.0	.13	-88.38
90.0	.17	-145.3	11.8	-30.2	-14.7	-29.9	.15	-96.66
100.0	.19	-145.2	11.8	-34.2	-14.8	-33.8	.17	-104.03
110.0	.21	-146.0	11.7	-38.1	-14.8	-37.7	.19	-110.73
120.0	.22	-147.1	11.7	-42.0	-14.9	-41.5	.21	-116.99
130.0	.24	-148.7	11.6	-45.8	-15.0	-45.2	.23	-122.91
140.0	.26	-150.7	11.6	-49.7	-15.1	-49.0	.25	-129.48
150.0	.28	-152.8	11.5	-53.5	-15.2	-52.7	.27	-133.87
160.0	.30	-155.2	11.4	-57.3	-15.4	-56.4	.29	-139.02
170.0	.32	-157.7	11.3	61.1	-15.5	-60.2	.31	-144.01
180.0	.34	-160.4	11.2	-64.9	-15.6	-63.9	.32	-148.89
190.0	.36	-163.2	11.2	-68.7	-15.8	-67.5	.34	-153.58
200.0	.37	-166.1	11.1	-72.5	-15.9	-71.2	.36	-158.18
210.0	.39	-169.1	11.0	-76.4	-16.1	-74.9	.38	-162.61
220.0	.41	-172.1	10.9	-80.2	-16.2	-78.6	.39	-167.07
230.0	.42	-175.3	10.7	-84.1	-16.4	-82.3	.41	-171.36
240.0	.44	-178.5	10.6	-88.0	-16.6	-86.0	.43	-175.65
250.0	.46	178.3	10.5	-91.9	-16.8	-89.7	.44	-179.76

Product Options

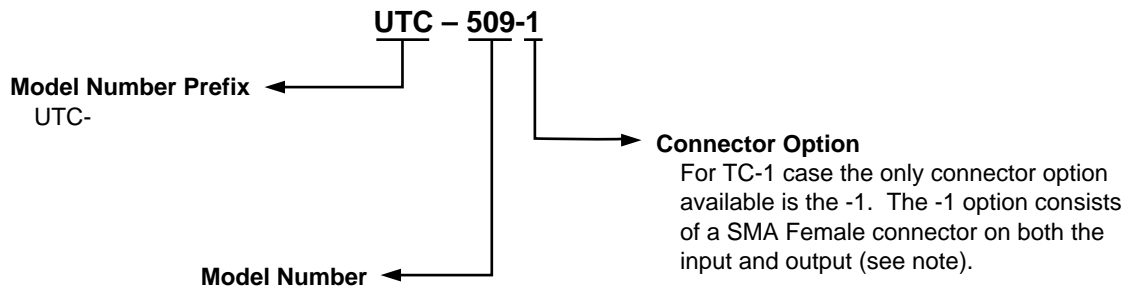
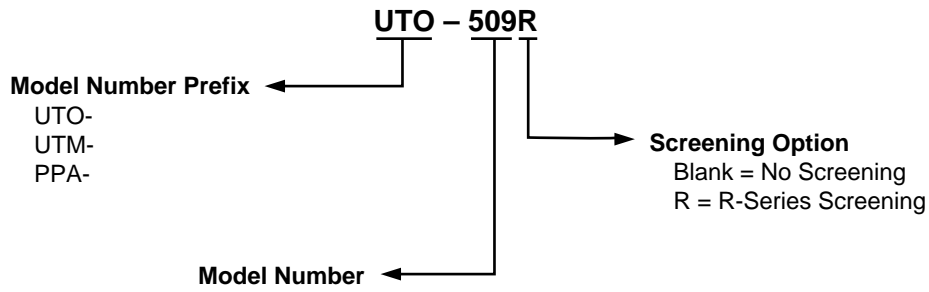

Note: R-Series screening is not available in the TC-1 case as the case is non-hermetic.

**Case Drawings
TO-8T**

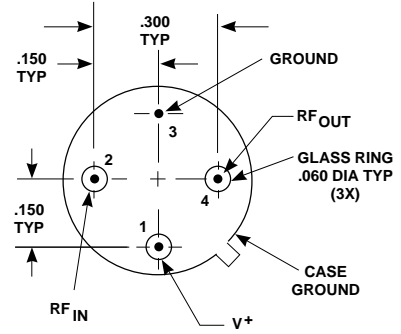
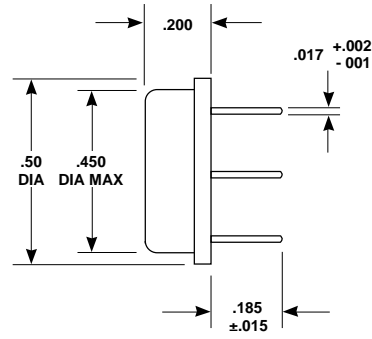
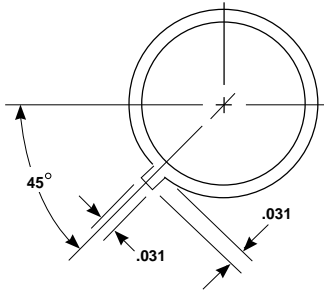

APPROXIMATE WEIGHT 2.1 GRAMS

- NOTES (UNLESS OTHERWISE SPECIFIED):**
 1. DIMENSIONS ARE SPECIFIED IN INCHES
 2. TOLERANCES: xx ± .02
 xxx ± .010

TC-1A

