



Transys
Electronics
LIMITED

RZ2538C/A - 25 Amp
RZ3538C/A - 35 Amp
RZ5038C/A - 50 Amp
Rectifier/Zener Automotive Alternator Diode

Data Sheet

Features

- * Epi Layer for tight control of parameters
- * Silicon oxide passivation for superior junction protection
- * Visual to Mil Std 750C
- * 100 % Tested
- * Low Reverse Leakage
- * Low Forward Voltage
- * Load Dump Capability

Anode Base Suffix "A" Cathode Base Suffix "C"

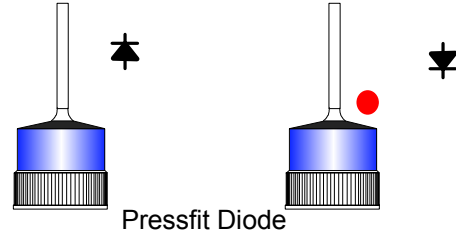

Characteristics at 25° C (Unless stated otherwise)	Maximum Forward Voltage	Reverse Breakdown Voltage	Maximum Reverse Leakage	Maximum Clamping Voltage	Maximum Forward Current @ Ta = 150° C	Non Repetitive Peak Forward Surge Current @ Ta = 150° C
Type Number	V _F Volt	V _{BR} Volt	I _R nA	V _{CL} Volt	I _{F (AVG)} Amp	I _{FSM} Amp
RZ2538C RZ2538A	1.05 @ 75A t = 300µ S < 2% Duty Cycle	38 - 42 @ 100mA	200 @ VR = 31Volt	< 45 @ IR = 2.8 x IF avg 80 µS < 2% duty Cycle	25	400 @ 8.3ms single half wave. (Jedec Method)
RZ3538C RZ3538A	1.05 @ 100A t = 300µ S < 2% Duty Cycle	38 - 42 @ 100mA	200 @ VR = 31Volt	< 45 @ IR = 2.8 x IF avg 80 µS < 2% duty Cycle	35	600 @ 8.3ms single half wave. (Jedec Method)
RZ5038C RZ5038A	1.05 @ 100A t = 300µ S < 2% Duty Cycle	38 - 42 @ 100mA	200 @ VR = 31Volt	< 45 @ IR = 2.8 x IF avg 80 µS < 2% duty Cycle	50	800 @ 8.3ms single half wave. (Jedec Method)

Power cycle requirement.

1. 10,000 cycles
2. I_F = 200% Rated current
3. Temperature rise 150° C
4. Excursion rate 37.5° C/Minute, +/- 5° C/Minute

Maximum Operating Temperature Range -65 to + 200° C
Maximum Storage Temperature Range -65 to + 200° C

Mechanical Dimensions

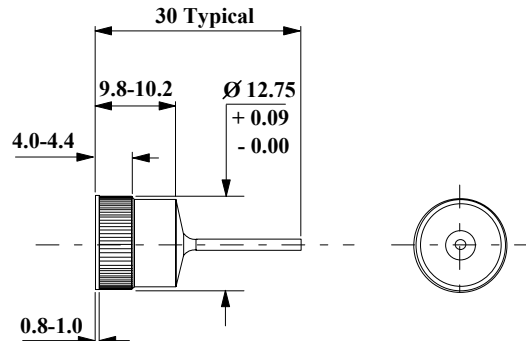

The information in this datasheet does not form part of any contract, quotation guarantee, warranty or representation, it has been produced in good faith and is believed to be accurate and may be changed without notice at anytime. Liability will not be accepted by Transys Electronics LTD for any consequences whatsoever in its use. This publication does not convey nor imply any license under patent or other intellectual industrial property rights. The products within this specification are not designed for use in any life support apparatus whatsoever where malfunction can be reasonably expected to cause personal injury or death. Customers using these products in the aforementioned applications do so at their own risk and agree to fully indemnify Transys Electronics LTD for any damage/ legal fees either direct, incidental or consequential from this improper use or sale.



Transys Electronics LTD
Birmingham UK.
Email: sales@transyselectronics.com
Website: www.transyselectronics.com
Tel: 44 (0) 121 776 6321
Fax 44 (0) 121 776 6997

SCD0861-1