

ATLANTIC VERSION TERMINATOR INTERFACE ADAPTER	PART NUMBER	REVISION	DESCRIPTION	FEED TYPE	CONVERT TO	PART NUMBERS REQUIRED					
	2150379-1	A	FINE CRIMP HEIGHT ADJUST	MECHANICAL	PNEUMATIC FEED	2119950-1	2119792-1	-	2119641-1	-	2063440-1
					SERVO LATCH PLATE	2119951-1	1901697-1	8-2150379-5	-	-	2168400-7 (QUANTITY 2)
					SMART APPLICATOR	2161326-1	-	8-2150379-4	-	-	-
	2150379-2	A	FINE CRIMP HEIGHT ADJUST	PNEUMATIC	MECHANICAL FEED	2119949-1	2063961-1	5-18022-5	2119653-1	-	-
					SERVO LATCH PLATE	2119951-1	1901697-1	8-2150379-5	-	-	2168400-7 (QUANTITY 2)
					SMART APPLICATOR	2161326-1	-	8-2150379-4	-	-	-
	2150379-5	A	FINE CRIMP HEIGHT ADJUST	SERVO LATCH PLATE ⁴	MECHANICAL FEED	2119949-1	2063961-1	5-18022-5	2119653-1	-	-
					PNEUMATIC FEED	2119950-1	2119792-1	-	2119641-1	-	2063440-1
	2150379-6	A	NON-CRIMP HEIGHT ADJUST	SERVO LATCH PLATE ⁴	-	-	-	-	-	-	-
					-	-	-	-	-	-	-
	2150379-7	A	FINE CRIMP HEIGHT ADJUST	NONE	-	-	-	-	-	-	-
	7-2150379-7	A	CRIMP TOOLING KIT	-	-	-	-	-	-	-	-

APPLICATOR DATA		
CRIMP	SIZE	TYPE
WIRE	2.54 mm [.100]	F
INSUL	-	-

APPLICATOR INSTRUCTIONS
408-10390

TERMINAL DATA: TE TERMINAL		TE CRIMP SPECIFICATION	
TERMINAL NAME: RING			
WIRE STRIP LENGTH		INSULATION DIAMETER RANGE	
3.58-4.34 mm [.141-.171 IN]			
TERMINAL APPLICATION SPECIFICATION	114-2084	-	-
TERMINALS APPLIED			
TE TERMINAL	TE TERMINAL	TE TERMINAL	TE TERMINAL
40668	40777	40816	

WIRE SIZE	CRIMP HEIGHT mm [INCH]	CRIMP HEIGHT REFERENCE SETTING
16 AWG	1.70 +/- 0.050 [.067 +/- .002]	4.6
18 AWG	1.52 +/- 0.050 [.060 +/- .002]	6.6
20 AWG	1.42 +/- 0.050 [.056 +/- .002]	7.6

- RECOMMENDED SPARE PARTS
- GREASE BEARING SURFACES LIGHTLY
- 3. LUBRICATE DAILY PER THE APPLICATOR INSTRUCTION SHEET SUPPLIED WITH THE APPLICATOR.
- APPLICATOR SPECIFIC DATA TO BE ENTERED INTO BLANK MEMORY CHIP AT ASSEMBLY. SEE BELOW FOR PART NUMBER:
 MECHANICAL FEED WITH "SMART APPLICATOR" CONVERSION: 8-2150379-4
 PNEUMATIC FEED WITH "SMART APPLICATOR" CONVERSION: 8-2150379-4
 SERVO FEED WITH "FINE CRIMP HEIGHT ADJUST": 8-2150379-5
 SERVO FEED WITH "NON-CRIMP HEIGHT ADJUST": 8-2150379-6
- 5. ADJUSTMENT OF THE STRIPPER MAY BE REQUIRED WHEN MOVING THE APPLICATOR BETWEEN BENCH AND LEADMAKER APPLICATIONS.
- APPLY PART NUMBER 1-23419-5 LOCTITE TO THREADS OF ITEMS 62. FOR -6 ONLY APPLY PART NUMBER 1-23419-5 LOCTITE TO THREADS OF ITEMS 37.
- GREASE THREADS, GROOVE AND O-RING ON ITEMS 35 & 252.
- MAGNET, ITEM 166 MUST BE ORIENTED CORRECTLY IN ORDER TO PROPERLY ACTUATE THE COUNTER.
- CRIMP HEIGHT REFERENCE SETTING WAS THE SETTING USED WHEN THE APPLICATOR WAS QUALIFIED AT THE FACTORY. ADJUSTMENT MAY BE NECESSARY WHEN RUNNING APPLICATOR IN THE FIELD.
- SPARE FEED CAM STORAGE LOCATION REFER TO INSTRUCTION SHEET FOR ADDITIONAL INFORMATION.
- THE RECOMMENDED SET-UP FOR END FEED APPLICATORS IS POST-FEED WITH ITEM 2119653-1. THE APPLICATOR CAN BE CONFIGURED FOR PRE-FEED WITH ITEM 2119652-1 BUT MAY ENCOUNTER PROBLEMS WITH SOME APPLICATIONS. FEED ISSUES OR TERMINAL JAMMING MAY OCCUR IN THE PRE-FEED CONFIGURATION.
- WHEN ASSEMBLING -6 NON-CRIMP HEIGHT ADJUST APPLICATOR USE SHIM PACK 2119957-2 TO ALIGN APPLICATOR'S MAXIMUM WIRE CRIMP HEIGHT AT NORMAL TERMINATOR SHUT HEIGHT
- 13. TERMINAL LUBRICANT IS RECOMMENDED.

***WARNING**
ON INSTALLATION, SET WIRE DISC, ITEM 40 TO LARGEST WIRE SIZE SETTING. USE OF SETTINGS BELOW MINIMUM REQUIRED CRIMP HEIGHT SETTING WILL CAUSE DAMAGE TO CRIMP TOOLING.

ATLANTIC VERSION
Shown on sheets 1 of 4 & 2 of 4
(Pacific version shown on sheets 3 of 4 & 4 of 4)

SET UP GAUGE	LOC	DIST	REVISIONS			
2119599-2	A	66	REV	DATE	OWN	APPD
			1	09OCT2013	GH	TE
			A	18NOV2013	GH	TE

-	-	1	-	-	-	2119957-2	APPLICATOR SHIM PACK	260
-	-	1	-	1	1	8-21084-0	O-RING, .676 ID, .070 DIA. MAT.	252
-	-	-	-	1	-	2119640-1	PUSH ROD, AIR FEED	250
-	-	-	-	1	-	2079988-1	BUSHING, LCH5-12, MISUMI	249
-	-	-	-	1	-	2119641-1	FEED CAM, AIR FEED	248
-	-	1	-	1	1	2119798-1	DETENT PIN	247
-	-	1	-	1	1	1-22279-3	SPRING, COMPRESSION	246
-	-	1	-	-	-	2119759-1	RAM, AMP STYLE, END FEED, NON-ADJUST	245
-	-	2	2	-	-	2168400-7	SHCS, LOW HEAD, RoHS, M5 X 10	240
-	-	-	-	-	1	2119580-1	MECHANICAL FEED ASSEMBLY	239
-	-	-	-	1	-	2063440-1	AIR FEED MODULE	238
-	-	1	1	1	-	2119740-2	TAG, IDENTIFICATION	213
-	-	REF	REF	-	-	1901697-1	FEED FINGER ASSEMBLY, EF	183
-	-	-	-	2	-	21045-3	RING, RETAIN, EXTERN, 3/16 CRESCENT	172
-	-	1	1	1	1	994969-1	MAGNET, RARE EARTH HIGH ENERGY	166
-	-	REF	REF	REF	REF	994970-2	COUNTER, MAGNETIC	164
-	-	-	-	1	-	240638-1	SPRING, FEED FINGER	163
-	-	-	-	1	-	3-23627-7	PIN, RETAIN, GRVD, 3/16 X .854	137
-	-	REF	REF	-	-	SEE NOTE 4	MEMORY CHIP, PROGRAMMED	135
-	-	1	1	1	-	1633743-1	SERVO FEED LATCH ASM	133
-	-	1	1	1	1	2119955-2	ASSY, LUBRICATOR, END FEED	84
-	-	1	1	1	1	455888-3	SPACER, CRIMPER	82
-	-	1	1	1	1	2119956-2	DOCUMENTATION PACKAGE	71
-	-	2	2	2	2	2-18032-2	SCR, SET, FLT POINT M3 X 10.0	70
-	-	1	-	-	1	2119740-1	TAG, IDENTIFICATION	67
-	-	2	2	2	2	2168078-1	SCREW, DRIVE, RH, RoHS, 2 x .188	66
-	-	1	-	1	1	2119793-1	LIMITER, ADJUSTMENT BOLT	63
	-	3	-	3	3	992763-5	SCR, SET, SOC, CONE POINT, M3 x 4.0	62
-	-	1	1	1	1	2079383-4	SCR, BHSC, RoHS (M4 X 8)	60
-	-	-	-	-	1	5-18022-5	SCR, HEX HD CAP, M4 X 6.0	59
-	-	-	-	-	1	2063961-1	FEED FINGER	58
-	-	4	4	4	4	2168400-4	SHCS, LOW HEAD, RoHS, M4 X 8	57
-	-	2	2	2	2	1-2168083-4	SCR, SKT HD CAP, RoHS, M4 X 5	56
-	-	2	2	2	2	5018030-2	NUT, HEX, REG, RoHS, M4	55
-	-	2	2	2	2	5018030-1	NUT, HEX, REG, RoHS, M3	54
-	-	2	2	2	2	986965-8	NUT, LOCK, HEX, TORQUE (M4)	53
-	-	-	-	-	1	2119792-1	PAWL, EF, AIR	51
-	-	-	-	-	1	18023-9	SCR, SKT HD CAP M4 X 6.0	49
-	-	-	-	-	1	2119652-1	FEED CAM, PRE FEED	48
-	-	-	-	-	1	2119653-1	FEED CAM, POST FEED	47
-	-	1	1	1	1	2119655-5	APPLICATOR BASIC ASSEMBLY, EF	46
-	-	1	-	1	1	2119369-1	RAM, AMP STYLE, END FEED	44
-	-	1	1	1	1	2079383-6	SCR, BHSC, RoHS (M8 X 12)	41
-	-	1	-	1	1	2119645-1	DISC, NUMBERED FA WIRE ADJUSTMENT	40
-	-	1	-	1	1	2119957-1	APPLICATOR SHIM PACK	39
	-	1	1	1	1	1-2119644-2	RAM WASHER, PRECISION	38
-	-	1	1	1	1	2119085-1	FA HEAD, ATLANTIC STYLE	37
-	-	1	-	1	1	2119092-1	BOLT, ADJUSTMENT	35
-	-	8	8	8	8	1-18028-2	WASHER, FLAT, REG M4	33
-	-	2	2	2	2	2168083-8	SCR, SKT HD CAP, RoHS, M4 X 16	31
-	-	2	2	2	2	1-2168083-0	SCR, SKT HD CAP, RoHS, M4 X 10	29
-	-	1	1	1	1	240639-1	STRIPPER (MACHINING)	27
-	-	2	2	2	2	1320906-1	STUD, THREADED	25
-	-	1	1	1	1	1752371-2	PLATE, STRIP GUIDE	24
-	-	2	2	2	2	2-22281-3	SPRING, COMPRESSION	22
-	-	1	1	1	1	1752373-4	DRAG	20
-	-	1	1	1	1	1901696-1	STRIP GUIDE, REAR	19
-	-	1	1	1	1	1901695-1	STRIP GUIDE, FRONT	18
-	-	4	4	4	4	1-2079383-1	SCR, BHSC, RoHS (M6 X 12)	17
	-	1	1	1	1	691901-2	REAR SHEAR PLATE, REVERSIBLE	11
-	-	2	2	2	2	240645-2	SPACER, SHEAR PLATE	10
	-	1	1	1	1	690783-2	PLATE, SPACER	9
	1	1	1	1	1	1803002-4	ANVIL, COMBINATION, END FEED	8
	-	1	1	1	1	2-691157-7	BLADE, SLUG	7
-	-	-	-	-	-	-	-	6
-	-	-	-	-	-	-	-	4
-	-	-	-	-	-	-	-	3
-	-	-	-	-	-	-	-	2
	1	1	1	1	1	456407-8	CRIMPER, WIRE PREMIUM	1

DIMENSIONS:		TOLERANCES UNLESS OTHERWISE SPECIFIED:		DWG		REV	
mm	0 PLC ±.5	1 PLC ±.13	2 PLC ±.013	3 PLC ±.013	4 PLC ±.0001	OFFNER	09OCT2013
	ANGLES	±.0001				ELBIN	09OCT2013
MATERIAL:	FINISH:	WEIGHT:	SCALE:	Customer Accessible Production Drawing	SCALE	1:1	SHEET 1 OF 4

STE TE Connectivity
Harrisburg, PA 17105-3608

Ocean End Feed
Applicator

SIZE: A1 CAGE CODE: 00779 DRAWING NO: 2150379

LOC		DIST		REVISIONS			
A	66	P	LTM	DESCRIPTION	DATE	DMN	APVD
		-	-	SEE SHEET 1	-	-	-

FEED TYPE MECHANICAL

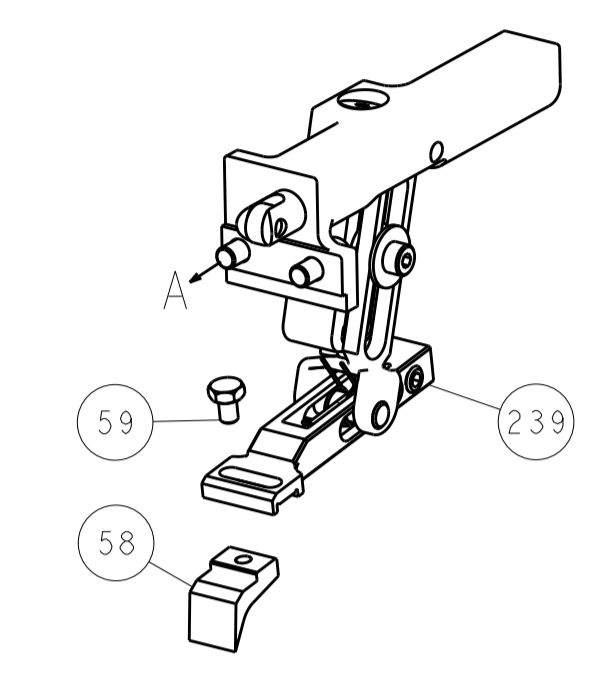

PNEUMATIC

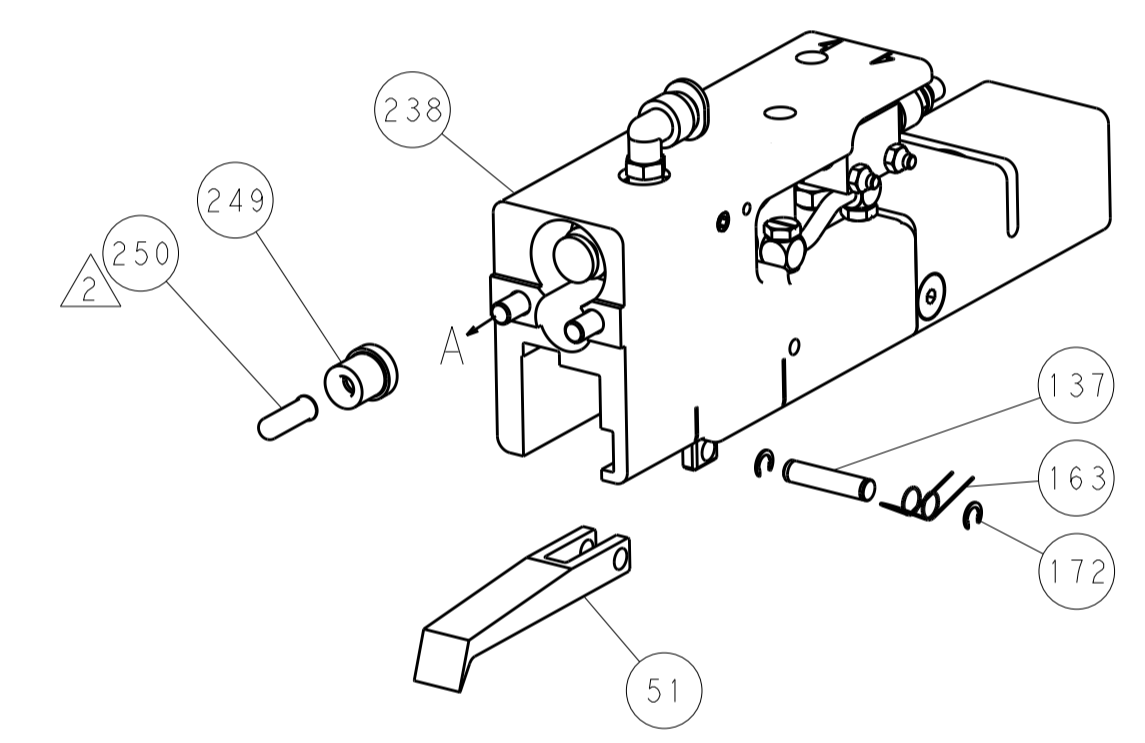

SERVO LATCH PLATE

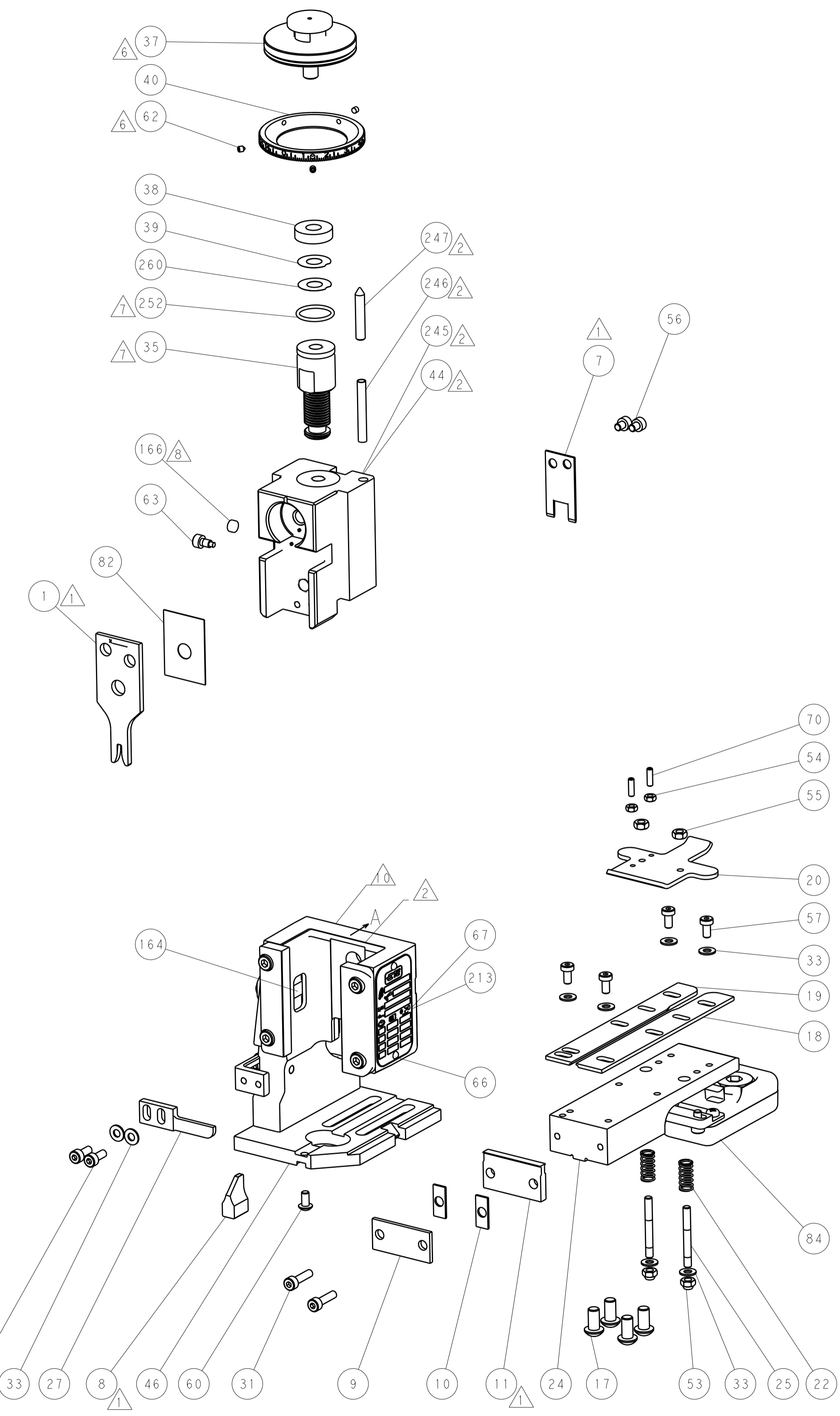
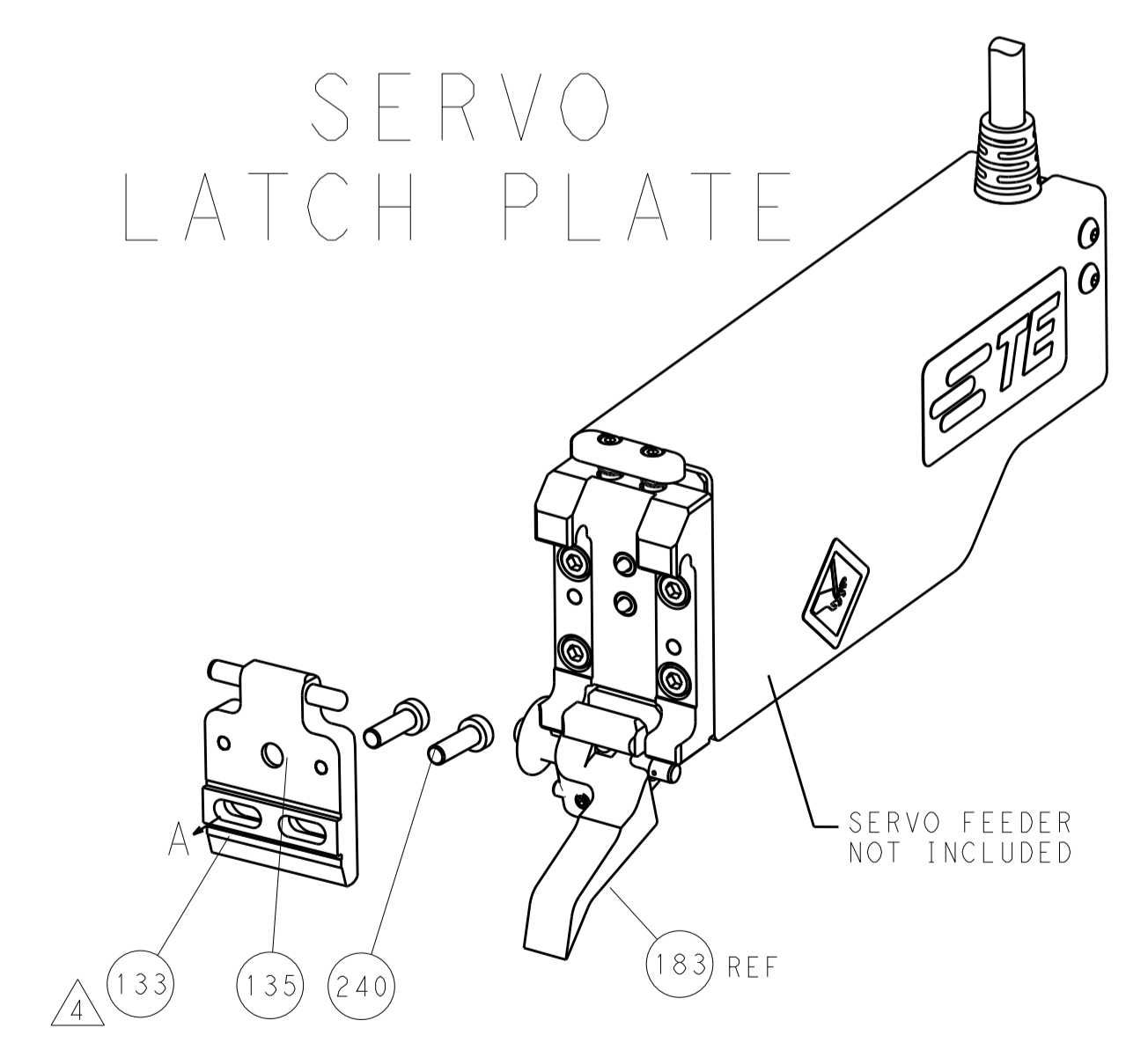

CAM POSITIONS

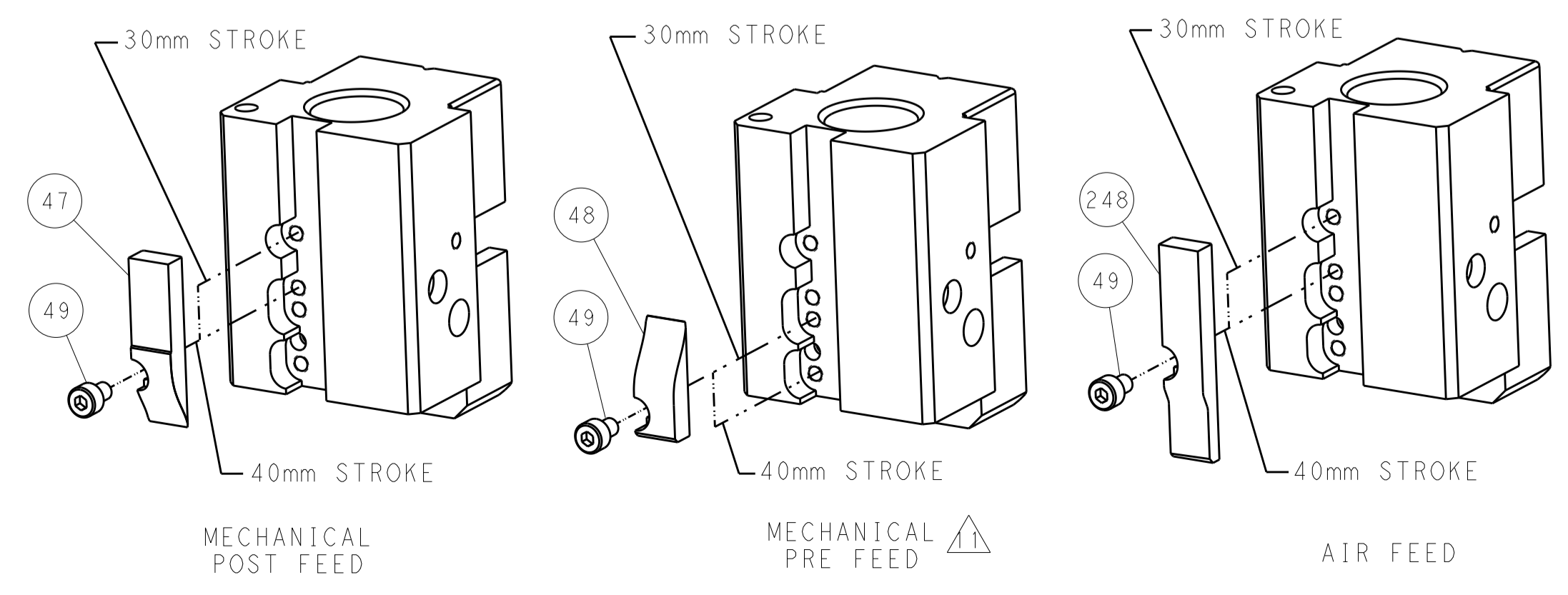

ATLANTIC VERSION
 Shown on sheets 1 of 4 & 2 of 4
 (Pacific version shown on sheets 3 of 4 & 4 of 4)

DIMENSIONS:		TOLERANCES UNLESS OTHERWISE SPECIFIED:		DWG: HOFFNER 09OCT2013		TE Connectivity	
mm		0 PLC ±0.5		CHK: T. ELBIN 09OCT2013		Harrisburg, PA 17105-3608	
Ø		1 PLC ±0.13		APVD: T. ELBIN 09OCT2013		NAME: Ocean End Feed Applicator	
H		2 PLC ±0.013		PRODUCT SPEC		SIZE: CAGE CODE DRAWING NO	
A		3 PLC ±0.001		APPLICATION SPEC		RESTRICTED TO	
R		4 PLC ±0.001		WEIGHT		A1 00779 ©=2150379	
FINISH		ANGLES		Customer Accessible Production Drawing		SCALE: 1:1 SHEET 2 OF 4 REV A	

PACIFIC VERSION TERMINATOR INTERFACE ADAPTER	PART NUMBER	REVISION	DESCRIPTION	FEED TYPE	APPLICATOR STYLE CONVERSION CHART						
					CONVERT TO	PART NUMBERS REQUIRED					
	2-2150379-1	A	FINE CRIMP HEIGHT ADJUST	MECHANICAL	PNEUMATIC FEED	2119950-1	2119792-1	-	2119641-2	-	2063440-1
					SERVO LATCH PLATE	2119951-1	1901697-1	8-2150379-5	-	-	2168400-7 (QUANTITY 2)
					SMART APPLICATOR	2161326-1	-	8-2150379-4	-	-	-
	2-2150379-2	A	FINE CRIMP HEIGHT ADJUST	PNEUMATIC	MECHANICAL FEED	2119949-1	2063961-1	5-18022-5	2119653-2	-	-
					SERVO LATCH PLATE	2119951-1	1901697-1	8-2150379-5	-	-	2168400-7 (QUANTITY 2)
					SMART APPLICATOR	2161326-1	-	8-2150379-4	-	-	-
	2-2150379-5	A	FINE CRIMP HEIGHT ADJUST	SERVO LATCH PLATE ⁴	MECHANICAL FEED	2119949-1	2063961-1	5-18022-5	2119653-2	-	-
					PNEUMATIC FEED	2119950-1	2119792-1	-	2119641-2	-	2063440-1
	2-2150379-7	A	FINE CRIMP HEIGHT ADJUST	NONE	-	-	-	-	-	-	-
	7-2150379-7	A	CRIMP TOOLING KIT	-	-	-	-	-	-	-	-

APPLICATOR DATA		
CRIMP	SIZE	TYPE
WIRE	2.54 mm [.100]	F
INSUL	-	-
APPLICATOR INSTRUCTIONS 408-10390		

TERMINAL DATA: TE TERMINAL		TE CRIMP SPECIFICATION
TERMINAL NAME: RING		
WIRE STRIP LENGTH		INSULATION DIAMETER RANGE
3.58-4.34 mm [.141-.171 IN]		∅ -
TERMINAL APPLICATION SPECIFICATION	114-2084	-
TERMINALS APPLIED		
TE TERMINAL	TE TERMINAL	TE TERMINAL
40668	40777	40816

WIRE SIZE	CRIMP HEIGHT mm [INCH]	CRIMP HEIGHT REFERENCE SETTING
16 AWG	1.70 +/- 0.050 [.067 +/- .002]	4.6
18 AWG	1.52 +/- 0.050 [.060 +/- .002]	6.6
20 AWG	1.42 +/- 0.050 [.056 +/- .002]	7.6

- RECOMMENDED SPARE PARTS
- GREASE BEARING SURFACES LIGHTLY
- 3. LUBRICATE DAILY PER THE APPLICATOR INSTRUCTION SHEET SUPPLIED WITH THE APPLICATOR.
- APPLICATOR SPECIFIC DATA TO BE ENTERED INTO BLANK MEMORY CHIP AT ASSEMBLY. SEE BELOW FOR PART NUMBER:
 MECHANICAL FEED WITH "SMART APPLICATOR" CONVERSION: 8-2150379-4
 PNEUMATIC FEED WITH "SMART APPLICATOR" CONVERSION: 8-2150379-4
 SERVO FEED WITH "FINE CRIMP HEIGHT ADJUST": 8-2150379-5
- 5. ADJUSTMENT OF THE STRIPPER MAY BE REQUIRED WHEN MOVING THE APPLICATOR BETWEEN BENCH AND LEADMAKER APPLICATIONS.
- APPLY PART NUMBER 1-23419-5 LOCTITE TO THREADS OF ITEMS 62.
- GREASE THREADS, GROOVE AND O-RING ON ITEMS 139 & 153.
- MAGNET, ITEM 166 MUST BE ORIENTED CORRECTLY IN ORDER TO PROPERLY ACTUATE THE COUNTER.
- CRIMP HEIGHT REFERENCE SETTING WAS THE SETTING USED WHEN THE APPLICATOR WAS QUALIFIED AT THE FACTORY. ADJUSTMENT MAY BE NECESSARY WHEN RUNNING APPLICATOR IN THE FIELD.
- SPARE FEED CAM STORAGE LOCATION REFER TO INSTRUCTION SHEET FOR ADDITIONAL INFORMATION.
- THE RECOMMENDED SET-UP FOR END FEED APPLICATORS IS POST-FEED WITH ITEM 2119653-1. THE APPLICATOR CAN BE CONFIGURED FOR PRE-FEED WITH ITEM 2119652-1 BUT MAY ENCOUNTER PROBLEMS WITH SOME APPLICATIONS. FEED ISSUES OR TERMINAL JAMMING MAY OCCUR IN THE PRE-FEED CONFIGURATION.
- 12. TERMINAL LUBRICANT IS RECOMMENDED.

***WARNING**
 ON INSTALLATION, SET WIRE DISC, ITEM 40 TO LARGEST WIRE SIZE SETTING. USE OF SETTINGS BELOW MINIMUM REQUIRED CRIMP HEIGHT SETTING WILL CAUSE DAMAGE TO CRIMP TOOLING.

PACIFIC VERSION
 Shown on sheets 3 of 4 & 4 of 4
 (Atlantic version shown on sheets 1 of 4 & 2 of 4)

SET UP GAUGE	LOC	DIST	REVISIONS			
2119599-2	A	66	REV	DATE	BY	APPV
			-	SEE SHEET 1	-	-

-	1	1	1	1	2119782-1	FINE ADJUST HEAD ASM, PACIFIC STYLE	251
-	-	-	1	-	2119640-1	PUSH ROD, AIR FEED	250
-	-	-	1	-	2079988-1	BUSHING, LCH5-12, MISUMI	249
-	1	1	1	1	1-22279-3	SPRING, COMPRESSION	246
-	-	2	-	-	2168400-7	SHCS, LOW HEAD, RoHS, M5 X 10	240
-	-	-	-	1	2119580-1	MECHANICAL FEED ASSEMBLY	239
-	-	-	-	1	2063440-1	AIR FEED MODULE	238
-	-	1	-	-	2119740-2	TAG, IDENTIFICATION	213
-	4	4	4	4	2079383-9	SCR, BHSC, RoHS (M6 X 20)	186
-	-	REF	-	-	1901697-1	FEED FINGER ASSEMBLY, EF	183
-	-	-	2	-	21045-3	RING, RETAIN, EXTERN, 3/16 CRESCENT	172
-	1	1	1	1	994969-1	MAGNET, RARE EARTH HIGH ENERGY	166
-	REF	REF	REF	REF	994970-2	COUNTER, MAGNETIC	164
-	-	-	1	-	240638-1	SPRING, FEED FINGER	163
-	1	1	1	1	8-21084-1	O-RING, .801 ID, .070 DIA. MAT.	153
-	-	-	1	-	2119641-2	FEED CAM, AIR FEED	152
-	1	1	1	1	2119798-2	DETENT PIN	145
-	1	1	1	1	2079383-8	SCR, BHSC, RoHS (M4 X 16)	144
-	-	-	-	1	2119653-2	FEED CAM, POST FEED	142
-	1	1	1	1	2119655-6	APPLICATOR BASIC ASSEMBLY, EF	141
-	1	1	1	1	2119651-1	RAM, ASIAN STYLE, END FEED	140
-	1	1	1	1	2119092-2	BOLT, ADJUSTMENT	139
-	-	-	1	-	3-23627-7	PIN, RETAIN, GRVD, 3/16 X .854	137
-	-	REF	-	-	SEE NOTE 4	MEMORY CHIP, PROGRAMMED	135
-	-	1	-	-	1633743-1	SERVO FEED LATCH ASM	133
-	1	1	1	1	2119955-2	ASSY, LUBRICATOR, END FEED	84
-	1	1	1	1	455888-3	SPACER, CRIMPER	82
-	1	1	1	1	2119956-2	DOCUMENTATION PACKAGE	71
-	2	2	2	2	2-18032-2	SCR, SET, FLT POINT M3 X 10.0	70
-	1	-	1	1	2119740-1	TAG, IDENTIFICATION	67
-	2	2	2	2	2168078-1	SCREW, DRIVE, RH, RoHS, 2 x .188	66
-	1	1	1	1	2119793-1	LIMITER, ADJUSTMENT BOLT	63
-	3	3	3	3	992763-5	SCR, SET, SOC, CONE POINT, M3 x 4.0	62
-	-	-	-	1	5-18022-5	SCR, HEX HD CAP, M4 X 6.0	59
-	-	-	-	1	2063961-1	FEED FINGER	58
-	4	4	4	4	2168400-4	SHCS, LOW HEAD, RoHS, M4 X 8	57
-	2	2	2	2	1-2168083-4	SCR, SKT HD CAP, RoHS, M4 X 5	56
-	2	2	2	2	5018030-2	NUT, HEX, REG, RoHS, M4	55
-	2	2	2	2	5018030-1	NUT, HEX, REG, RoHS, M3	54
-	2	2	2	2	986965-8	NUT, LOCK, HEX, TORQUE (M4)	53
-	-	-	-	1	2119792-1	PAWL, EF, AIR	51
-	-	-	-	2	18023-9	SCR, SKT HD CAP M4 X 6.0	49
-	-	-	-	1	2119652-1	FEED CAM, PRE FEED	48
-	1	1	1	1	2079383-6	SCR, BHSC, RoHS (M8 X 12)	41
-	1	1	1	1	2119645-1	DISC, NUMBERED FA WIRE ADJUSTMENT	40
-	1	1	1	1	2119957-1	APPLICATOR SHIM PACK	39
-	1	1	1	1	1-2119644-2	RAM WASHER, PRECISION	38
-	8	8	8	8	1-18028-2	WASHER, FLAT, REG M4	33
-	2	2	2	2	2168083-8	SCR, SKT HD CAP, RoHS, M4 X 16	31
-	2	2	2	2	1-2168083-0	SCR, SKT HD CAP, RoHS, M4 X 10	29
-	1	1	1	1	240639-1	STRIPPER (MACHINING)	27
-	2	2	2	2	1320906-1	STUD, THREADED	25
-	1	1	1	1	1752371-2	PLATE, STRIP GUIDE	24
-	2	2	2	2	2-22281-3	SPRING, COMPRESSION	22
-	1	1	1	1	1752373-4	DRAG	20
-	1	1	1	1	1901696-1	STRIP GUIDE, REAR	19
-	1	1	1	1	1901695-1	STRIP GUIDE, FRONT	18
-	1	1	1	1	691901-2	REAR SHEAR PLATE, REVERSIBLE	11
-	2	2	2	2	240645-2	SPACER, SHEAR PLATE	10
-	1	1	1	1	690783-2	PLATE, SPACER	9
-	1	1	1	1	1803002-4	ANVIL, COMBINATION, END FEED	8
-	1	1	1	1	2-691157-7	BLADE, SLUG	7
-	-	-	-	-	-	-	6
-	-	-	-	-	-	-	4
-	-	-	-	-	-	-	3
-	-	-	-	-	-	-	2
-	1	1	1	1	456407-8	CRIMPER, WIRE PREMIUM	1

DIMENSIONS:		TOLERANCES UNLESS OTHERWISE SPECIFIED:		DWG		NAME	
mm	0 PLC ±.5	1 PLC ±.5	2 PLC ±.13	3 PLC ±.013	4 PLC ±.0001	ANGLES ±.0001	FINISH
MATERIAL		FINISH		CHK	OFFNER 09OCT2013	CHK	T. ELBIN 09OCT2013
APV		T. ELBIN 09OCT2013		APV	T. ELBIN 09OCT2013	TE Connectivity Harrisburg, PA 17105-3608	
APPLICATION SPEC		APPLICATION SPEC		PRODUCT SPEC		Ocean End Feed Applicator	
WEIGHT		SCALE		SIZE		CAGE CODE DRAWING NO	
Customer Accessible Production Drawing		SCALE 1:1		SIZE A		00779 ©=2150379	
SHEET 3 OF 4		REV A		RESTRICTED TO		-	

LOC		DIST		REVISIONS			
A	66	P	LTM	DESCRIPTION	DATE	OWN	APVD
		-	-	SEE SHEET 1	-	-	-

FEED TYPE MECHANICAL

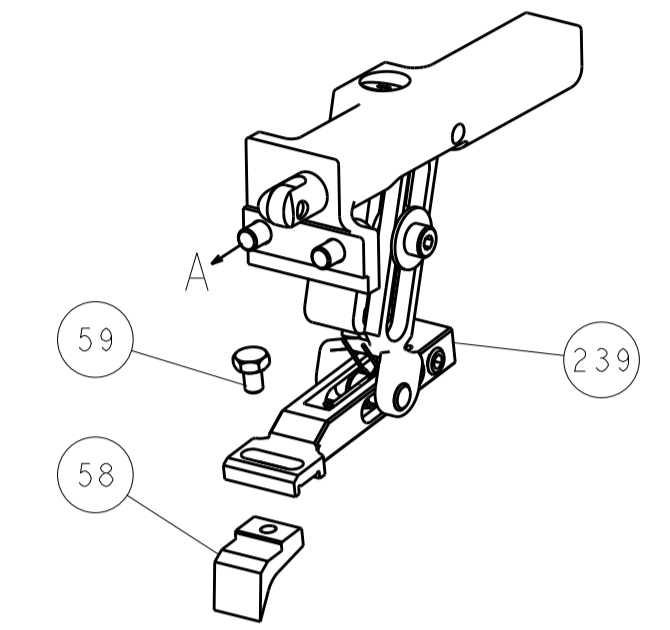

PNEUMATIC

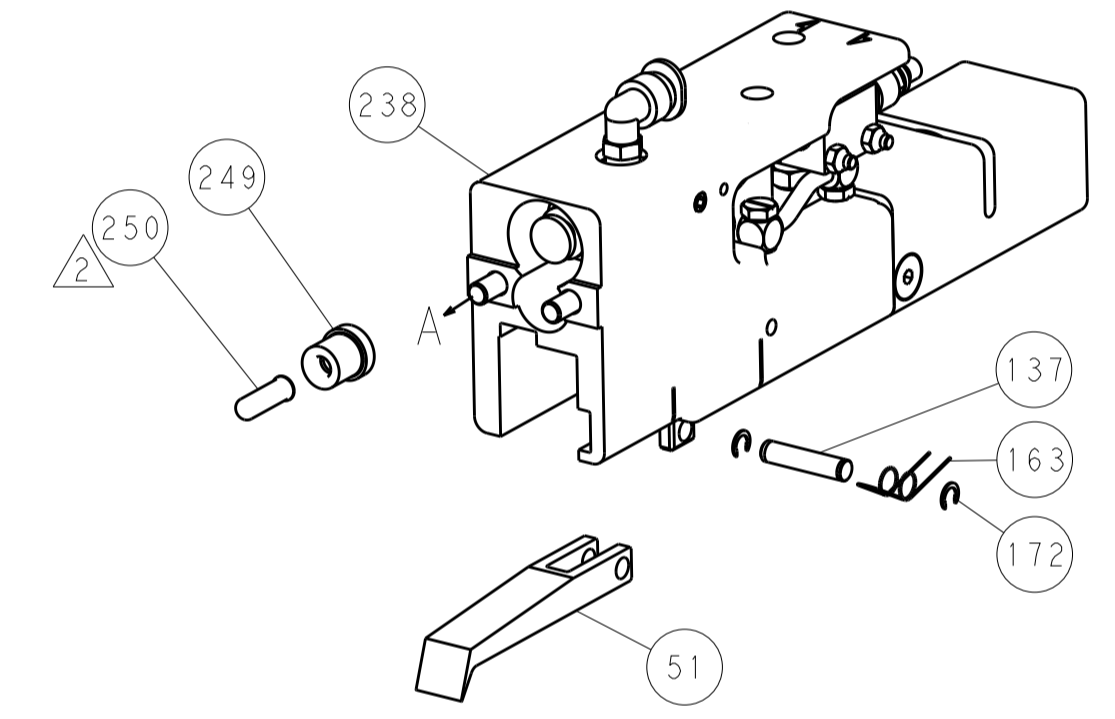

SERVO LATCH PLATE

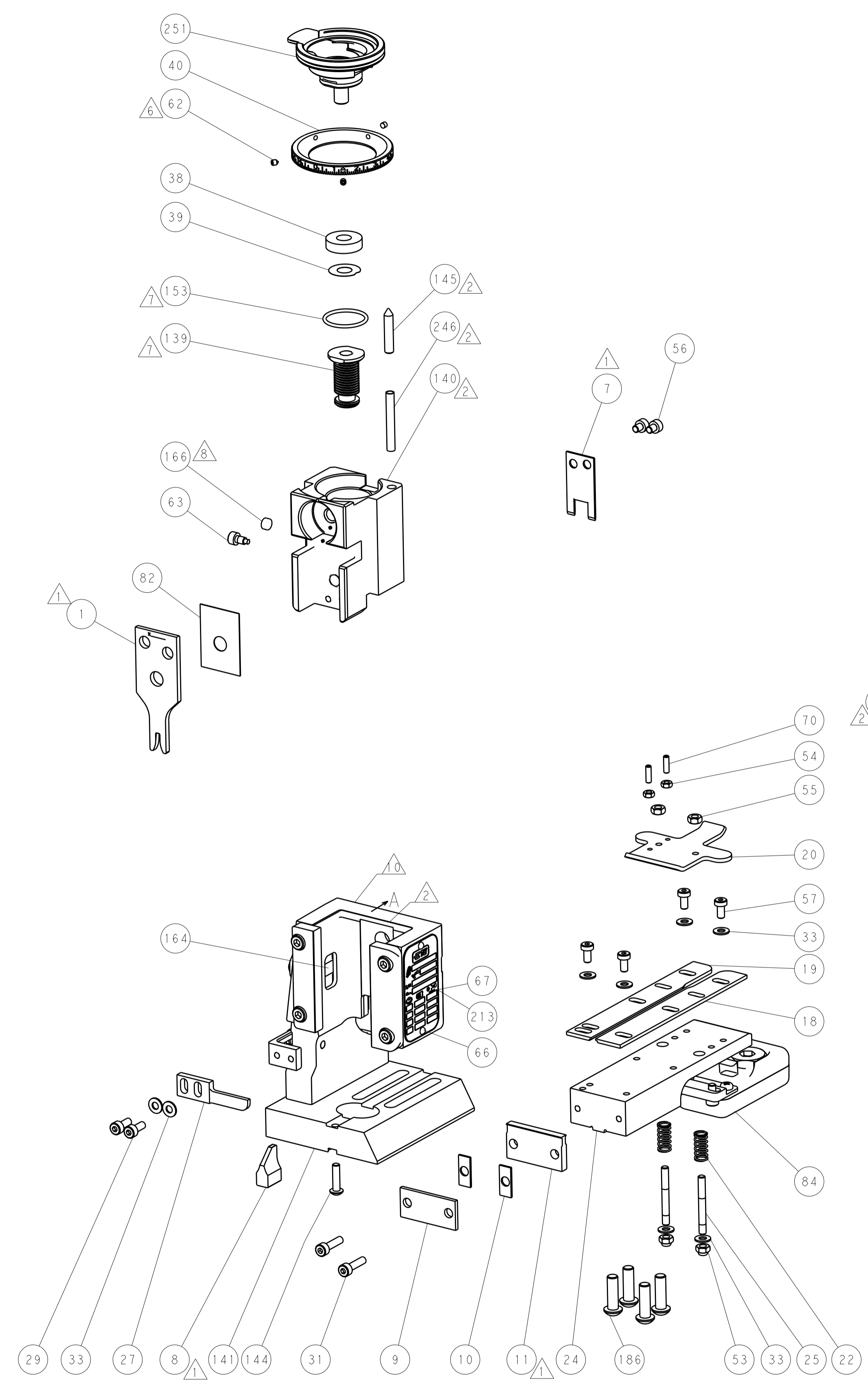
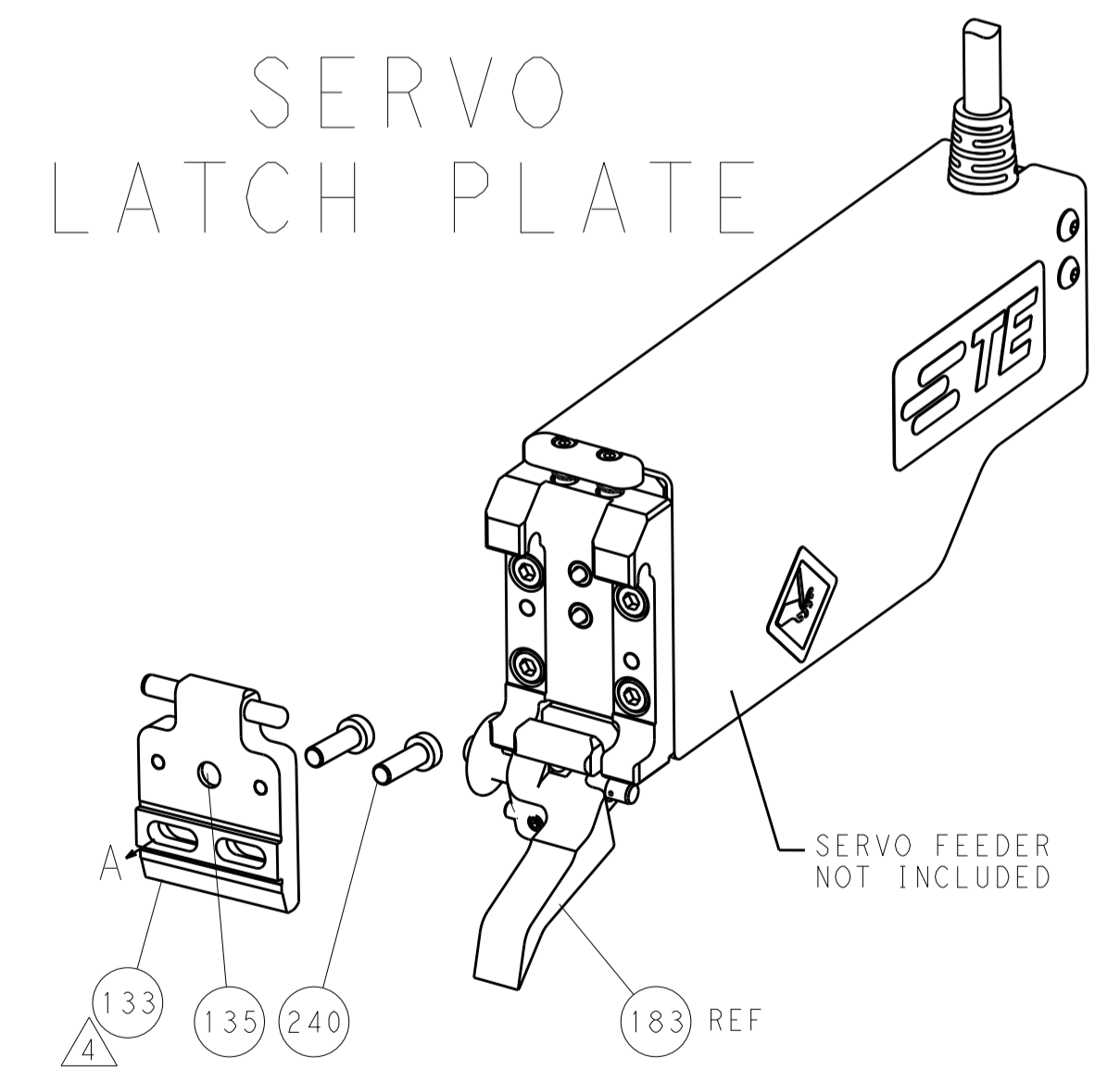

CAM POSITIONS

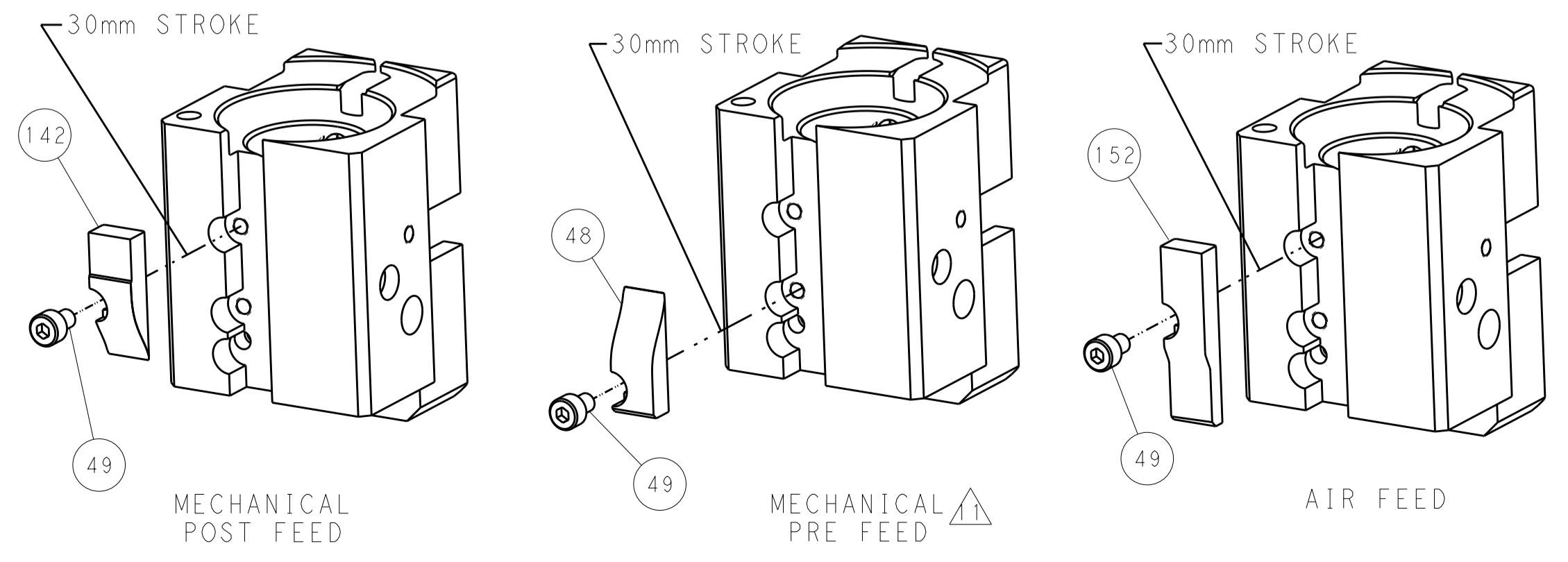

PACIFIC VERSION
 Shown on sheets 3 of 4 & 4 of 4
 (Atlantic version shown on sheets 1 of 4 & 2 of 4)

<small>THIS DRAWING IS UNPUBLISHED. RELEASED FOR PUBLICATION. IT IS THE PROPERTY OF TYCO ELECTRONICS CORPORATION AND IS TO BE USED ONLY FOR THE PURPOSES AND IN THE MANNER SPECIFIED BY THE DRAWING. IT IS TO BE RETURNED TO TYCO ELECTRONICS CORPORATION UPON REQUEST.</small>		DWN: HOFFNER 09OCT2013 CHK: T.ELBIN 09OCT2013 APVD: T.ELBIN 09OCT2013	TE Connectivity Harrisburg, PA 17105-3608
DIMENSIONS: mm TOLERANCES UNLESS OTHERWISE SPECIFIED: 0 PLC ±.5 1 PLC ±.5 2 PLC ±.13 3 PLC ±.013 4 PLC ±.0013 ANGLES ±.1		NAME: Ocean End Feed Applicator PRODUCT SPEC: APPLICATION SPEC: WEIGHT: SCALE: 1:1	SIZE: A1 CAGE CODE: 00779 DRAWING NO: C-2150379 SHEET 4 OF 4 REV A