

RFPA3805

GaAs HBT 2-Stage Power Amplifier
700MHz to 2700MHz

RFMD's RFPA3805 is a GaAs HBT linear power amplifier specifically designed for Wireless Infrastructure applications. Using a highly reliable GaAs HBT fabrication process, this high performance two-stage amplifier achieves high linearity over a broad frequency range. Its external matching allows for use across various radio platforms within 700MHz to 2700MHz. The RFPA3805 can also be optimized for high-efficiency applications.

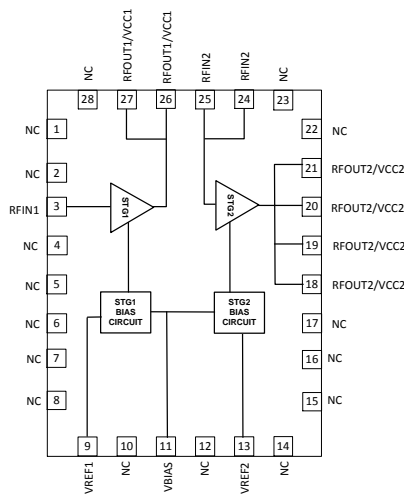

Functional Block Diagram

Ordering Information

RFPA3805SQ	Sample bag with 25 pieces
RFPA3805SR	7" Reel with 100 pieces
RFPA3805TR13	13" Reel with 2500 pieces
RFPA3805PCK-410	728MHz to 768MHz PCBA with 5-piece sample bag
RFPA3805PCK-411	2110MHz to 2170MHz PCBA with 5-piece sample bag
RFPA3805PCK-412	2580MHz to 2690MHz PCBA with 5-piece sample bag



Package: QFN, 28-pin,
4.0mm x 5.0mm

Features

- High Gain 20.5dB at 2.14GHz
- High Linearity, OIP3 = 47.5dBm at 2.14GHz
- Off-chip Interstage for Design Flexibility
- Independent Bias Control for Each Stage
- Power-down Capability
- 700MHz to 2700MHz Operation

Applications

- GaAs Driver for Base Station Amplifier
- PA Stage for Commercial Wireless Infrastructure
- Final Stage PA in Femtocell and Base Station Repeater Applications
- Final Stage PA in High Efficiency, High Power Applications
- Class AB Operation for GSM, DCS, PCS, UMTS, TD-SCDMA, LTE, and WLAN Transceiver Applications

Absolute Maximum Ratings

Parameter	Rating	Unit
Device Voltage (V_{CC1} , V_{CC2} , V_{BIAS} , V_{REF1} , V_{REF2})	6	V
Device Current – Stage 1	600	mA
Device Current – Stage 2	2400	mA
V_{REF1} , V_{REF2} Current	5	mA
V_{REF1} , V_{REF2} Device Voltage	4	V
CW Input Power, 50 Ω Load, 748MHz Band	21	dBm
CW Input Power, 50 Ω Load, 2140MHz and 2640MHz Bands	26	dBm
Modulated (WCDMA) Input Power, 6:1 Output VSWR, 748MHz Band	13	dBm
Modulated (CDMA) Input Power, 6:1 Output VSWR, 2140MHz and 2640MHz Bands	23	dBm
Operating Temperature Range (T_L)	-40 to +85	$^{\circ}$ C
Operating Junction Temperature (T_J)	160	$^{\circ}$ C
Max Storage Temperature	-40 to +150	$^{\circ}$ C
ESD Rating – Human Body Model (HBM)	Class 1C	
Moisture Sensitivity Level	MSL1	

Notes:

1. The Maximum ratings must all be met simultaneously
2. $P_{DISS} = P_{DC} + P_{RFIN} - P_{ROUT}$
3. $T_J = T_L + P_{DISS} * R_{TH}$

Nominal Operating Parameters

Parameter	Specification			Unit	Condition
	Min	Typ	Max		
728MHz to 768MHz					$V_{CC1} = V_{CC2} = V_{BIAS} = 5.0V$, $V_{REF1} = V_{REF2} = 5.0V$, Temp = 25$^{\circ}$C, optimized for -60dBc ACPR at rated power
Frequency		748		MHz	
Input Power (P_{IN})			2	dBm	Max recommended continuous input power, load VSWR = 2:1
Gain		33.4		dB	
Output IP3		46.8		dB	19dBm per tone, 1MHz spacing, optimized for best ACPR
ACPR		-63.5	-55	dBc	RF output power = 21dBm, WCDMA 3GPP 3.5, test model 1, 64 DPCH
P1dB		34.4		dBm	
Input Return Loss		-18		dB	
Output Return Loss		-13		dB	
Noise Figure		4.6		dB	



Caution! ESD sensitive device.



RFMD Green: RoHS status based on EU Directive 2011/65/EU (at time of this document revision), halogen free per IEC 61249-2-21, < 1000ppm each of antimony trioxide in polymeric materials and red phosphorus as a flame retardant, and <2% antimony in solder.

Exceeding any one or a combination of the Absolute Maximum Rating conditions may cause permanent damage to the device. Extended application of Absolute Maximum Rating conditions to the device may reduce device reliability. Specified typical performance or functional operation of the device under Absolute Maximum Rating conditions is not implied.

Parameter	Specification			Unit	Condition
	Min	Typ	Max		
2110MHz to 2170MHz					$V_{CC1} = V_{CC2} = V_{BIAS} = 5.0V$, $V_{REF1} = V_{REF2} = 5.0V$, Temp = 25°C, optimized for -60dBc ACPR at rated power
Frequency		2140		MHz	
Input Power (P_{IN})			11	dBm	Max recommended continuous input power, load VSWR = 2:1
Gain		20.5		dB	
Output IP3		47.5		dB	19dBm per tone, 1MHz spacing, optimized for best ACPR
ACPR		-60.4	-55	dBc	RF output power = 21dBm, WCDMA 3GPP 3.5, test model 1, 64 DPCH
P1dB		33.1		dBm	
Input Return Loss		-19		dB	
Output Return Loss		-11		dB	
Noise Figure		5		dB	
2580MHz to 2690MHz					$V_{CC1} = V_{CC2} = V_{BIAS} = 5.0V$, $V_{REF1} = V_{REF2} = 5.0V$, Temp = 25°C, optimized for -60dBc ACPR at rated power
Frequency		2640		MHz	
Input Power (P_{IN})			9	dBm	Max recommended continuous input power, load VSWR = 2:1
Gain		18.8		dB	
Output IP3		44.3		dB	19dBm per tone, 1MHz spacing, optimized for best ACPR
ACPR		-60.6	-55	dBc	RF output power = 19dBm, WCDMA 3GPP 3.5, test model 1, 64 DPCH
P1dB		32.6		dBm	
Input Return Loss		-17		dB	
Output Return Loss		-11		dB	
Noise Figure		5.6		dB	
Power Supply					Temp = 25°C, bias condition
Stage 1 Operating Current (Quiescent)	120	166	210	mA	At $V_{CC1} = V_{CC2} = V_{BIAS} = 5.0V$, $V_{REF1} = V_{REF2} = 5.0V$
Stage 2 Operating Current (Quiescent)	560	675	780	mA	
V_{CC} Operating Voltage	4.75	5	5.25	V	
V_{BIAS} Operating Voltage	4.75	5	5.25	V	$V_{BIAS} = V_{CC}$ under normal operating condition
V_{REF1} , V_{REF2}	5	5	5	V	
Stage 1 Thermal Resistance (R_{TH1})		38		°C/W	Junction-to-back side of IC at $R_{FOUT} = 30dBm$
Stage 2 Thermal Resistance (R_{TH2})		6		°C/W	
Shutdown Leakage Current			6	µA	At $V_{CC1} = V_{CC2} = V_{BIAS} = 5.0V$, $V_{REF1} = V_{REF2} = 0V$

Typical Performance: $V_{CC1} = V_{CC2} = V_{BIAS} = 5V$, $V_{REF1} = V_{REF2} = 5V$
 (728MHz to 768MHz Application Circuit)

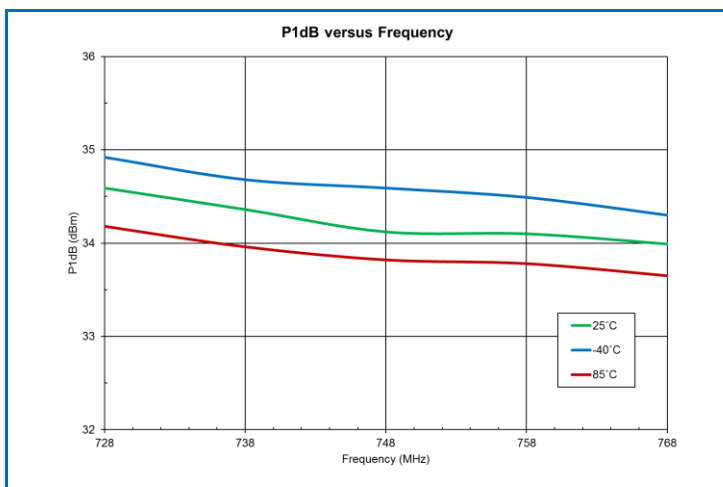
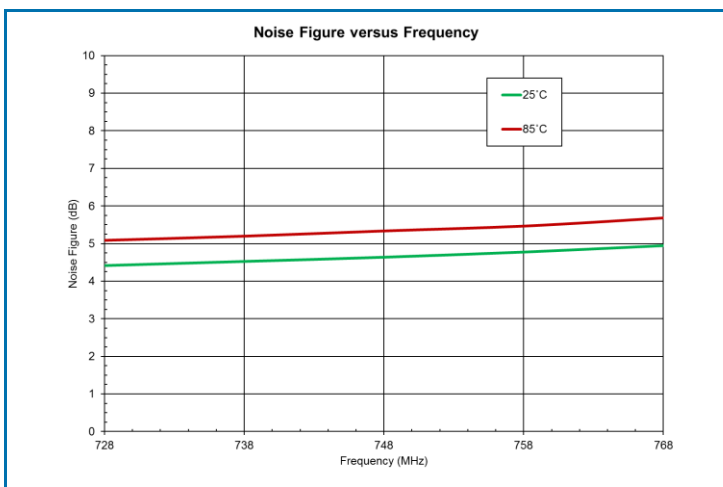
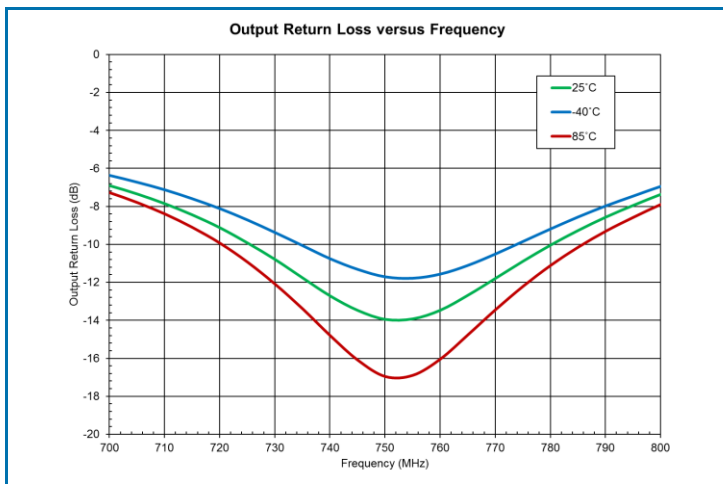
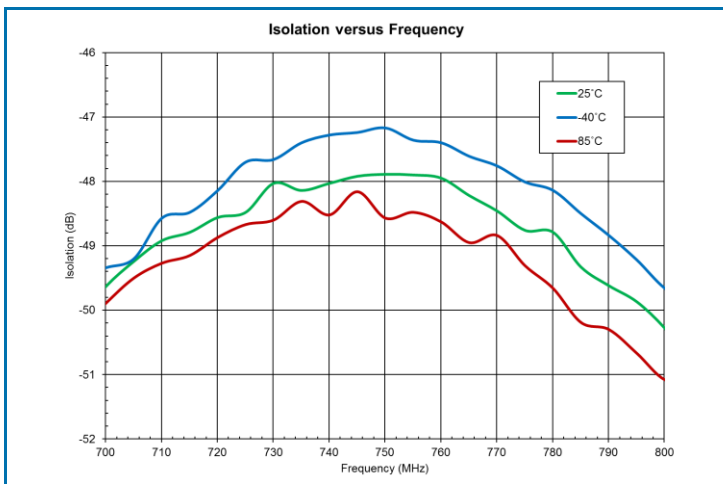
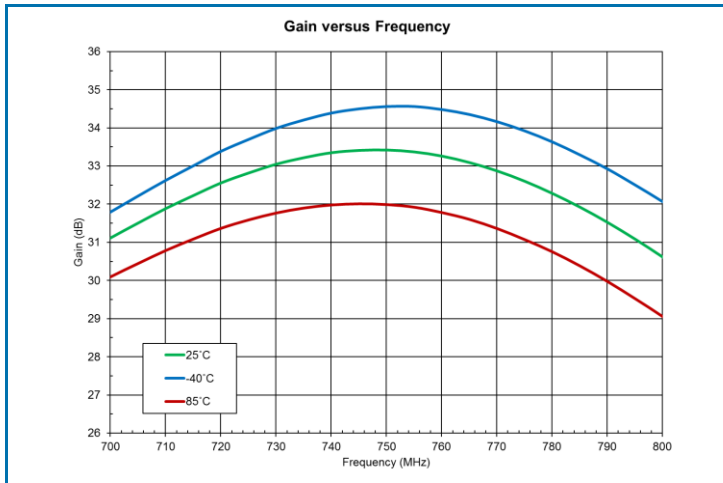
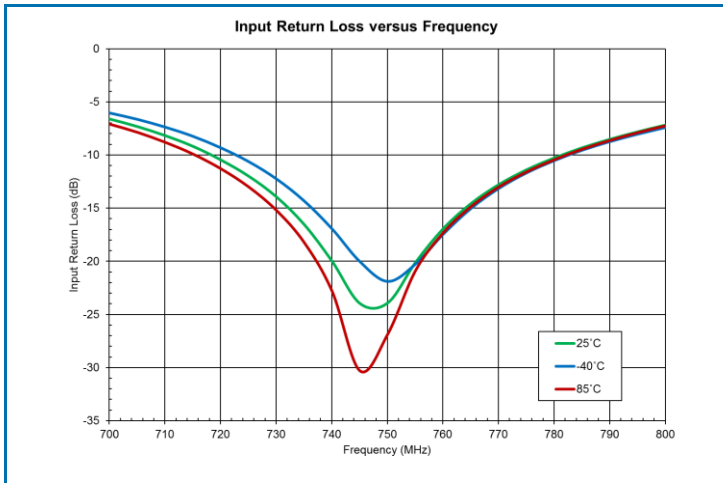

Typical Performance: $V_{CC1} = V_{CC2} = V_{BIAS} = 5V$, $V_{REF1} = V_{REF2} = 5V$
 (728MHz to 768MHz Application Circuit)

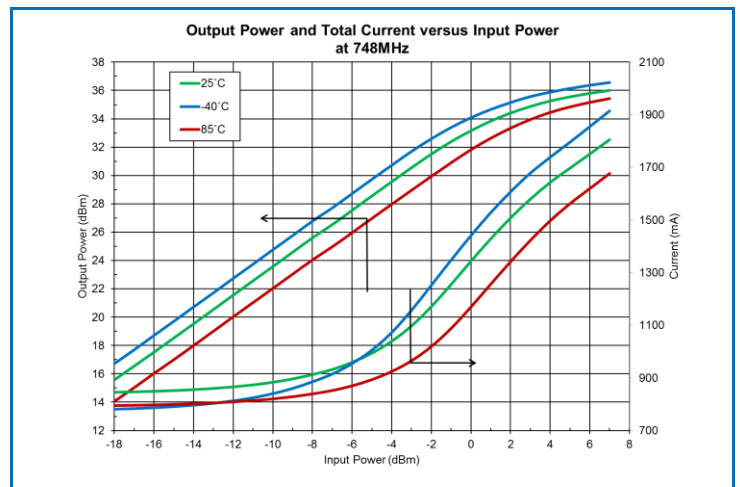
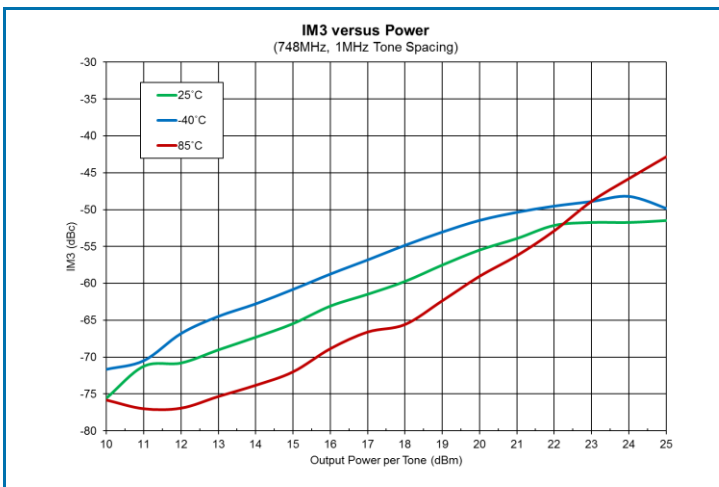
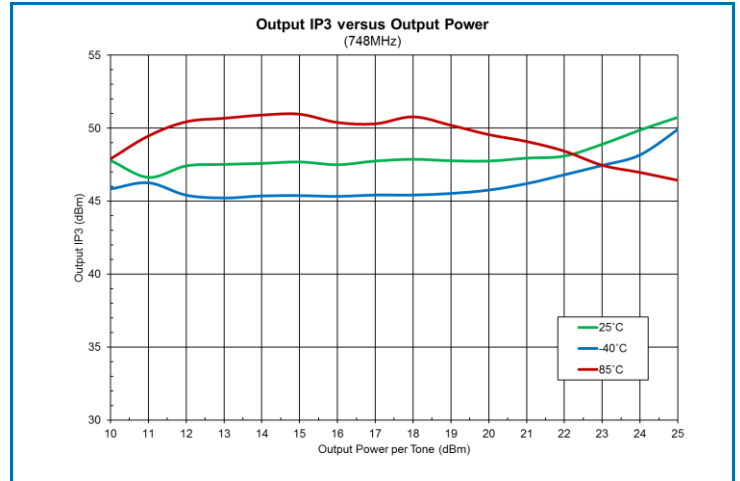
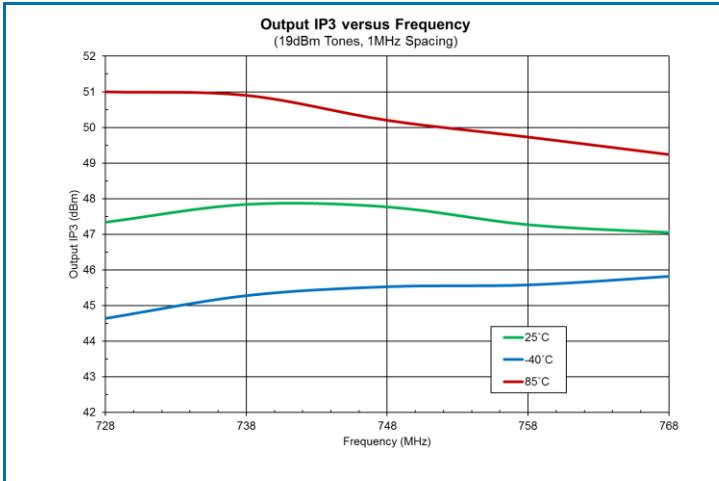
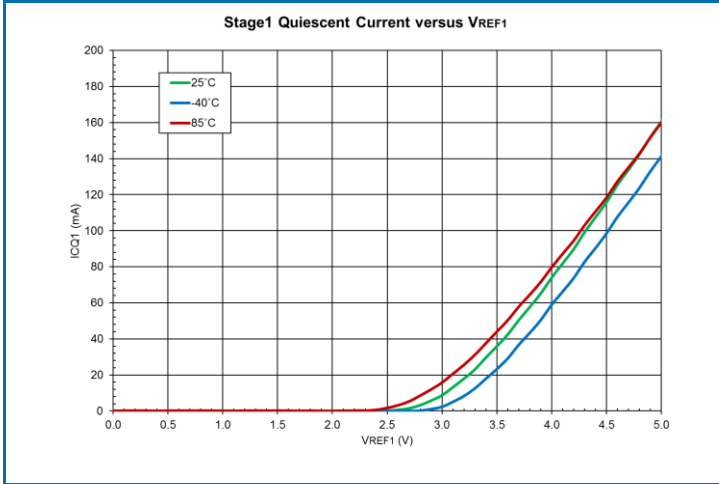

Typical Performance: $V_{CC1} = V_{CC2} = V_{BIAS} = 5V$, $V_{REF1} = V_{REF2} = 5V$
 (728MHz to 768MHz Application Circuit)

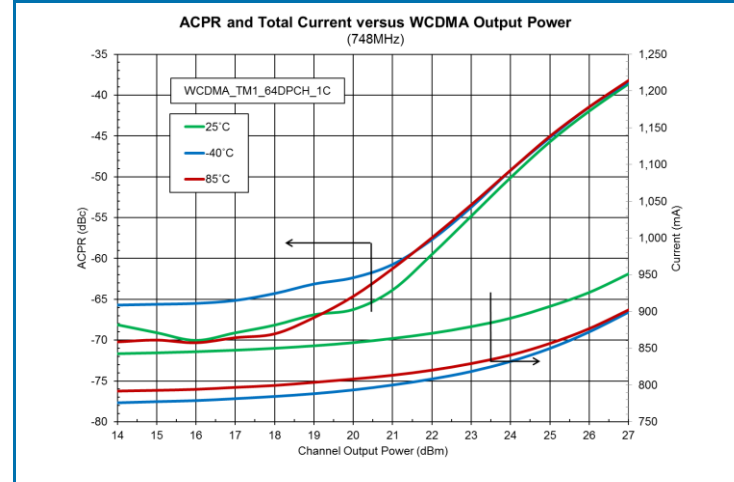
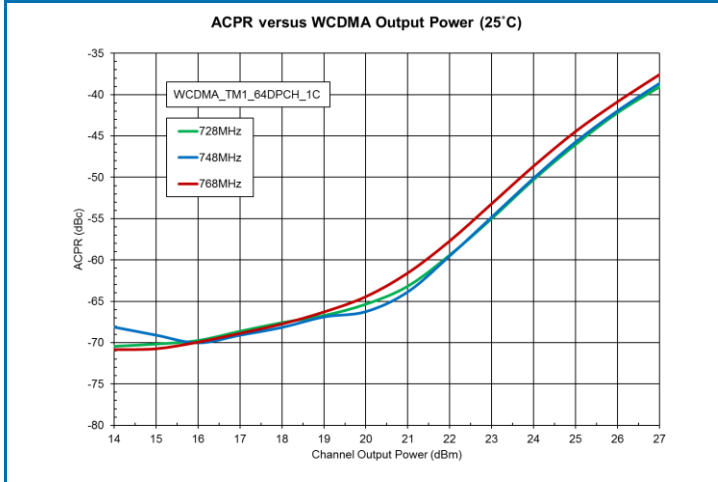

Evaluation Board Schematic 728MHz to 768MHz Application Circuit

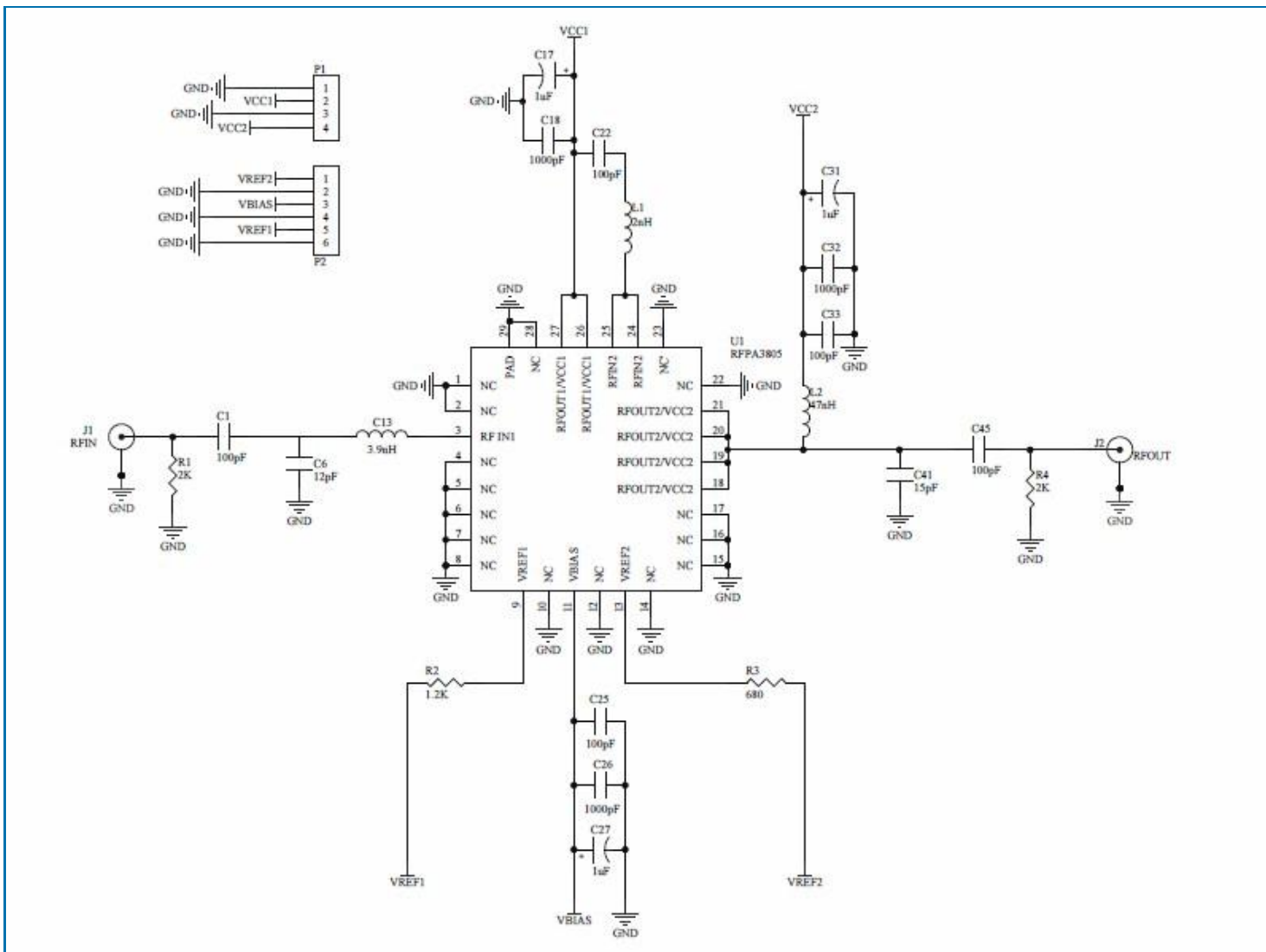

Evaluation Board Bill of Materials (BOM) 728MHz to 768MHz Application Circuit

Description	Reference Designator	Manufacturer	Manufacturer's P/N
RFPA3805 Evaluation Board			RFPA3805-410(A)
700MHz to 2700MHz, 2W, 5V, High Gain Linear PA in 4mm x 5mm QFN	U1	RFMD	RFPA3805
CAP, 100pF, 5%, 50V, C0G, 0402	C1, C22, C25, C33, C45	Murata Electronics	GRM1555C1H101JA01D
CAP, 12Pf, 5%, 50V, C0G, 0402	C6	Murata Electronics	GRM1555C1H120JA01D
IND, 3.9nH, +/-0.1nH, T/F, 0402	C13	Murata Electronics	LQP15MN3N9B02D
CAP, 1µF, 10%, 16V, X7R, 1206	C17, C27, C31	Murata Electronics	GRM31MR71E105KA01L
CAP, 1000pF, 10%, 50V, X7R, 0603	C18	Murata Electronics	GRM188R71H102KA01D
CAP, 1000pF, 10% 50V, X7R, 0402	C26, C32	Murata Electronics	GRM155R71H102KA01D
CAP, 15pF, 5%, 50V, HI-Q, 0402	C41	Murata Electronics	GJM1555C1H150JB01D
IND, 2nH, +/-0.1nH, T/F, 0402	L1	Murata Electronics	LQP15MN2N0B02D
IND, 47nH, 5%, W/W, 0603	L2	Coilcraft	0603HC-47NXJLW
CONN, SMA, 4-HOLE PANEL MOUNT JACK	J1-J2	Gigalane Co., Ltd.	PA-S00-000
CONN, HDR, ST, PLRZD, 4-PIN, 0.100"	P1	ITW Pancon	MPSS100-4-C
CONN, HDR, St, PLRZD, 6-PIN, 0.100"	P2	ITW Pancon	MPSS100-6-C
RES, 2K, 5%, 1/6W, 0402	R1, R4	Kamaya, Inc.	RMC1/16S-202JTH
RES, 1.2K, 5%, 1/6W, 0402	R2	Kamaya, Inc.	RMC1/16S-122JTH
RES, 680Ω, 5%, 1/6W, 0402	R3	Kamaya, Inc.	RMC1/16S-681JTH
HEATSINK, BLOCK, TEST FIX, 1.5" x 2.0"			EEF-101217
SCREW, 2-56 x 3/16", SOCKET HEAD	S1-S9	McMaster-Carr Supply Co.	92196A076

Evaluation Board Assembly Drawing 728MHz to 768MHz Application Note

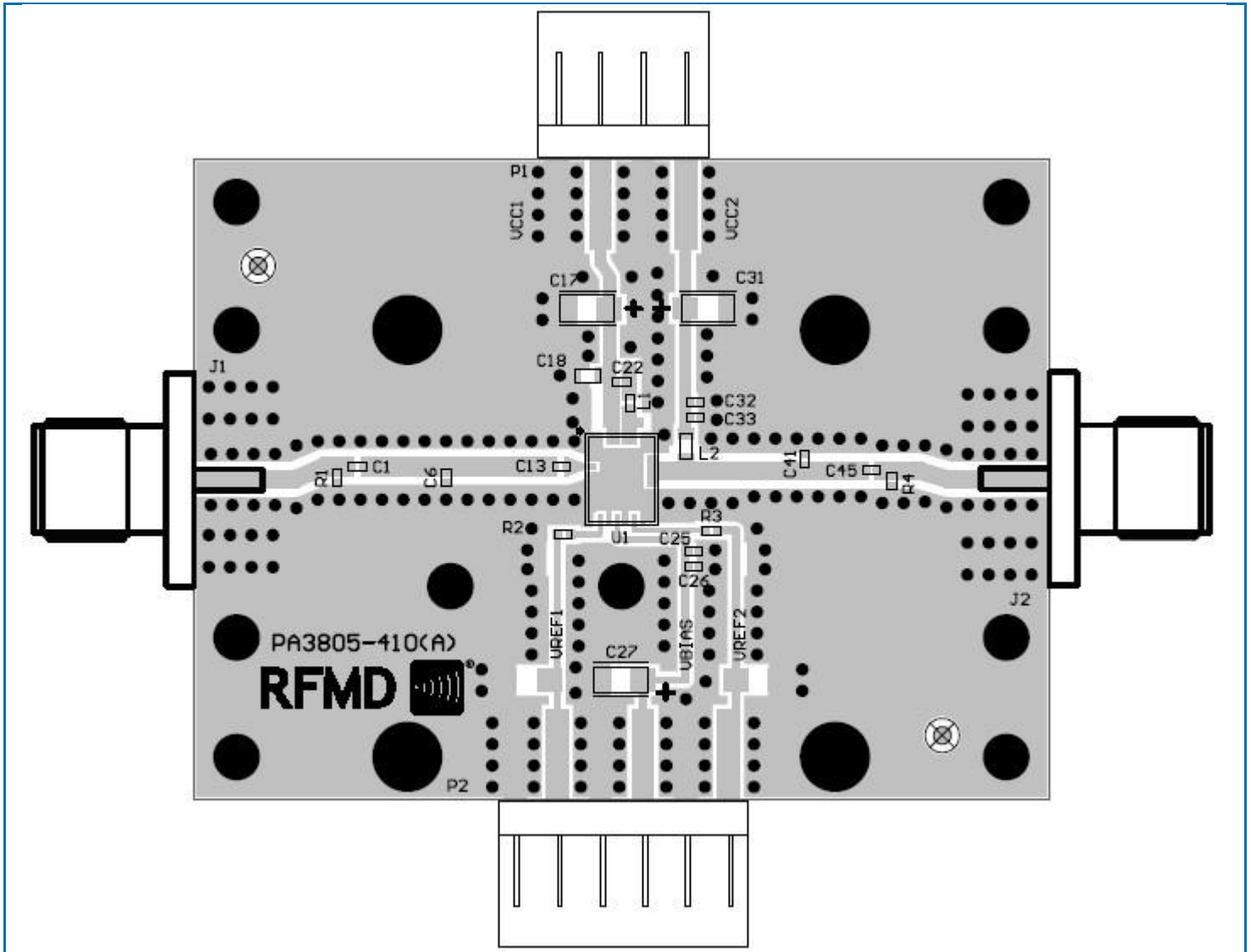

Typical Performance: $V_{CC1} = V_{CC2} = V_{BIAS} = 5V$, $V_{REF1} = V_{REF2} = 5V$
 (2110MHz to 2170MHz Application Circuit)

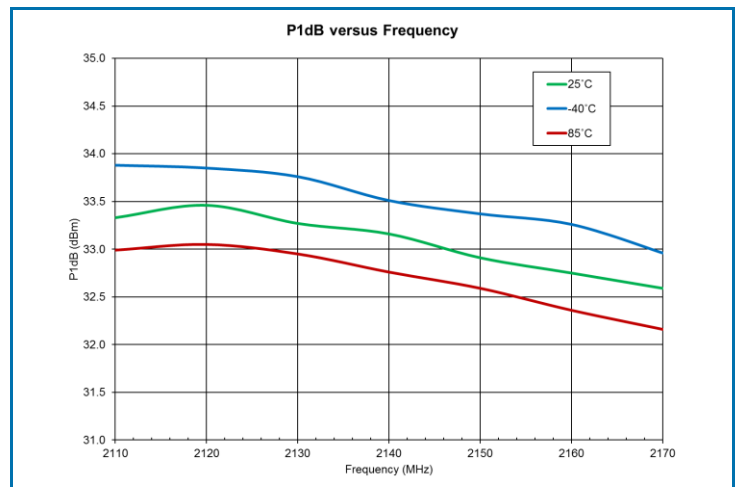
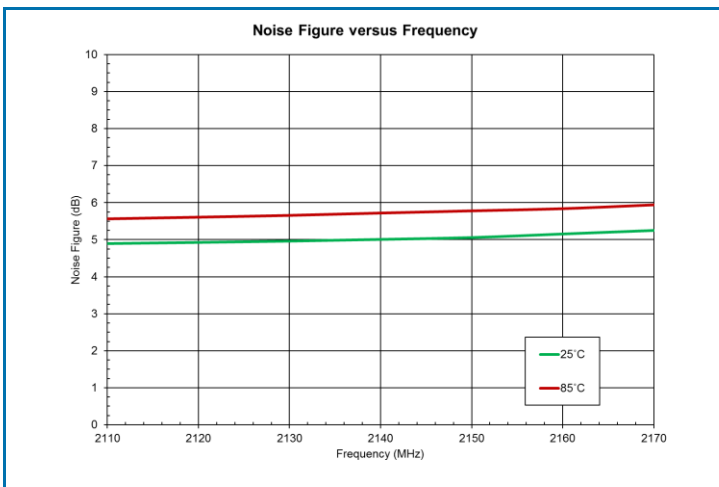
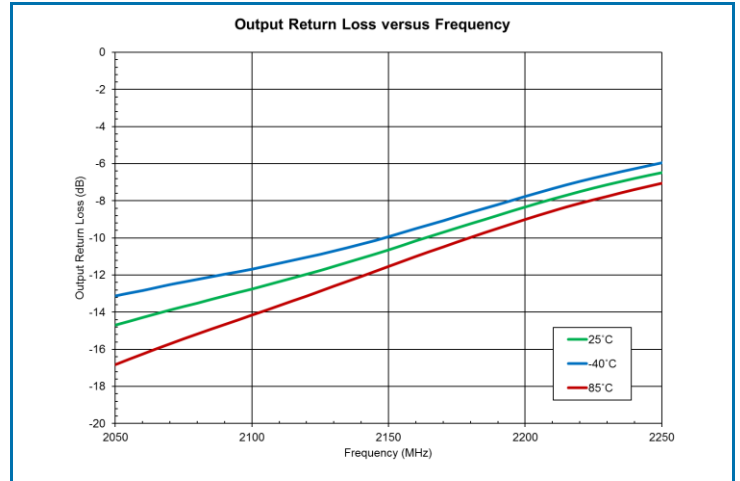
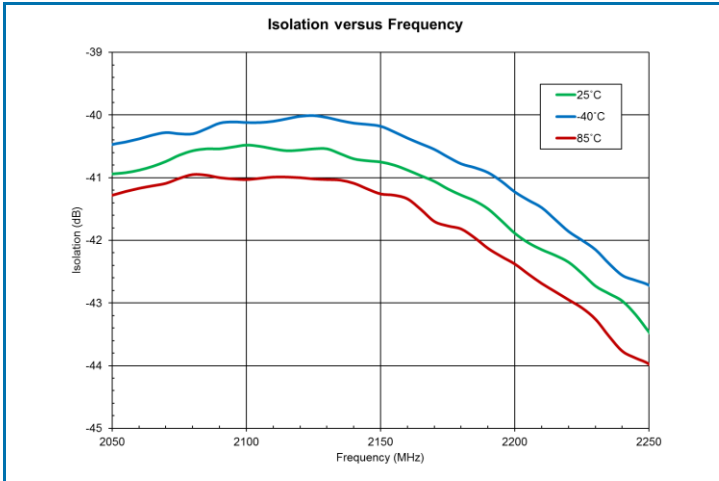
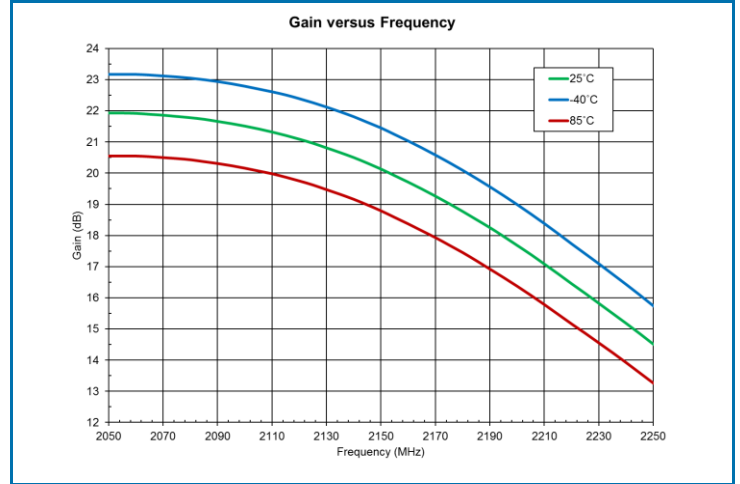
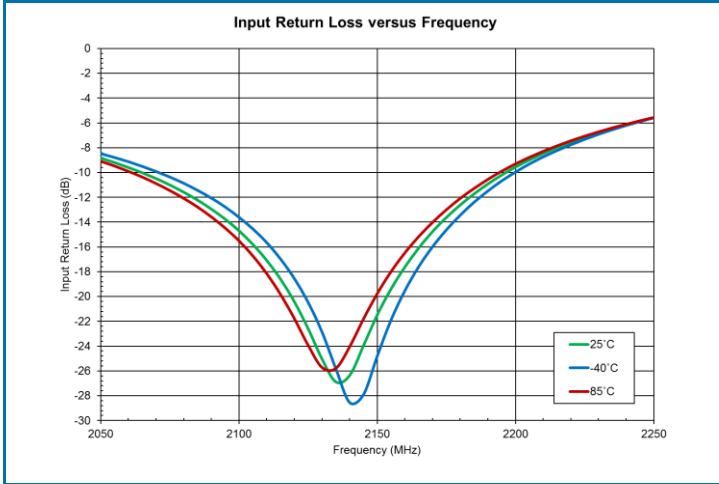

Typical Performance: $V_{CC1} = V_{CC2} = V_{BIAS} = 5V$, $V_{REF1} = V_{REF2} = 5V$
 (2110MHz to 2170MHz Application Circuit)

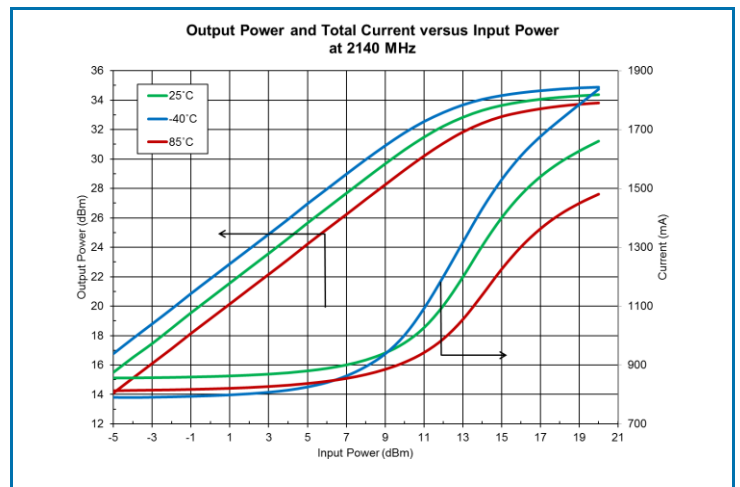
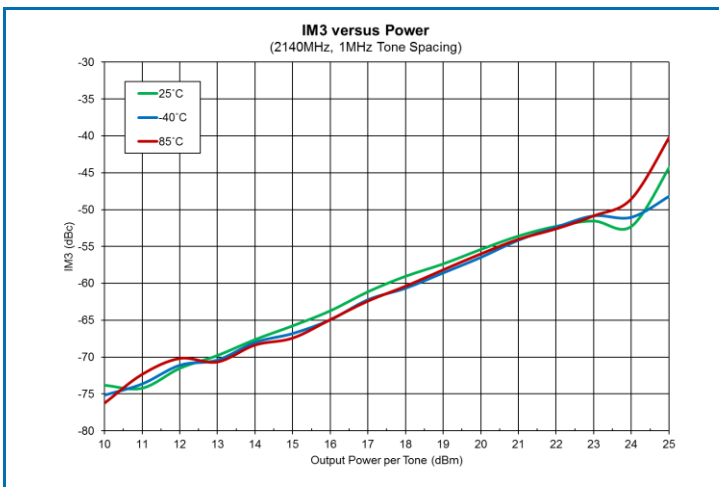
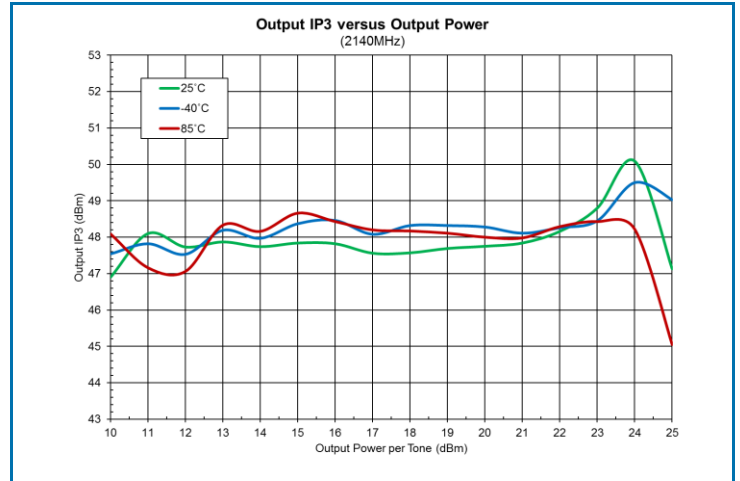
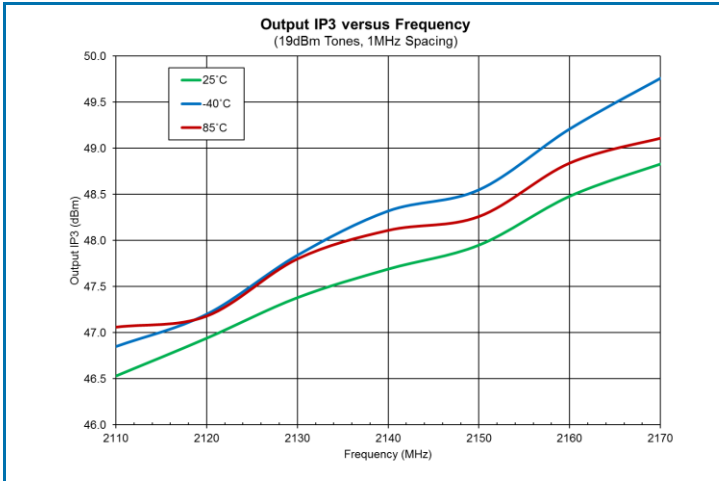
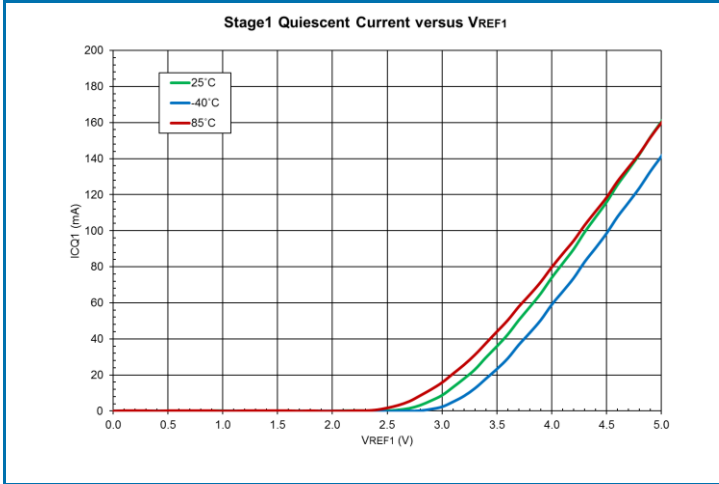

Typical Performance: $V_{CC1} = V_{CC2} = V_{BIAS} = 5V$, $V_{REF1} = V_{REF2} = 5V$
 (2110MHz to 2170MHz Application Circuit)

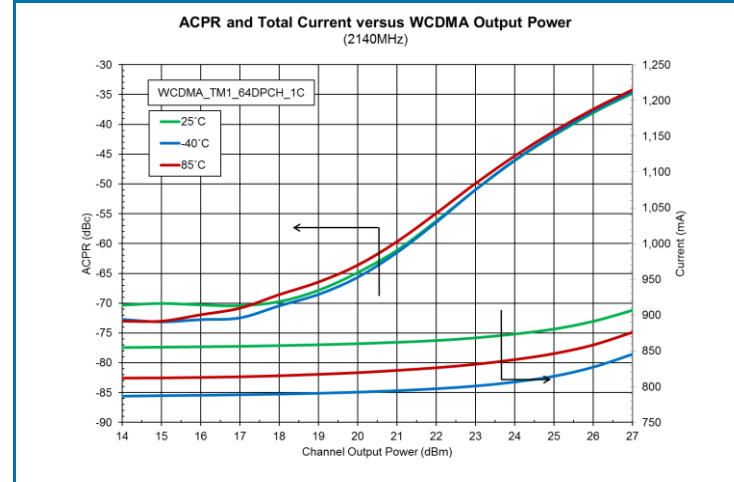
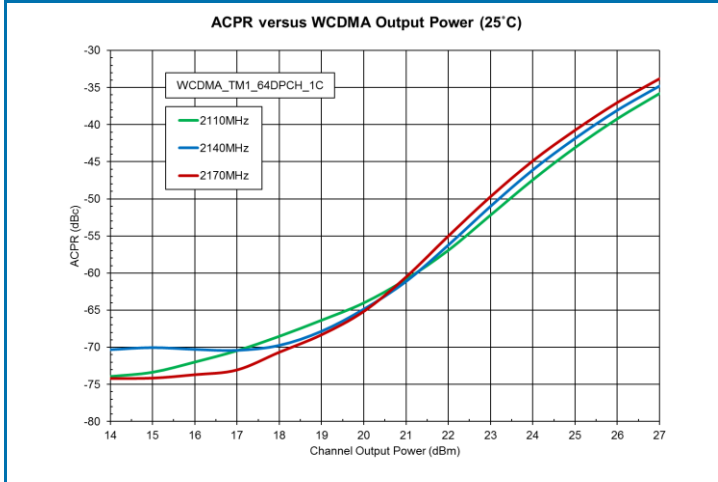

Evaluation Board Schematic 2110MHz to 2170MHz Application Circuit

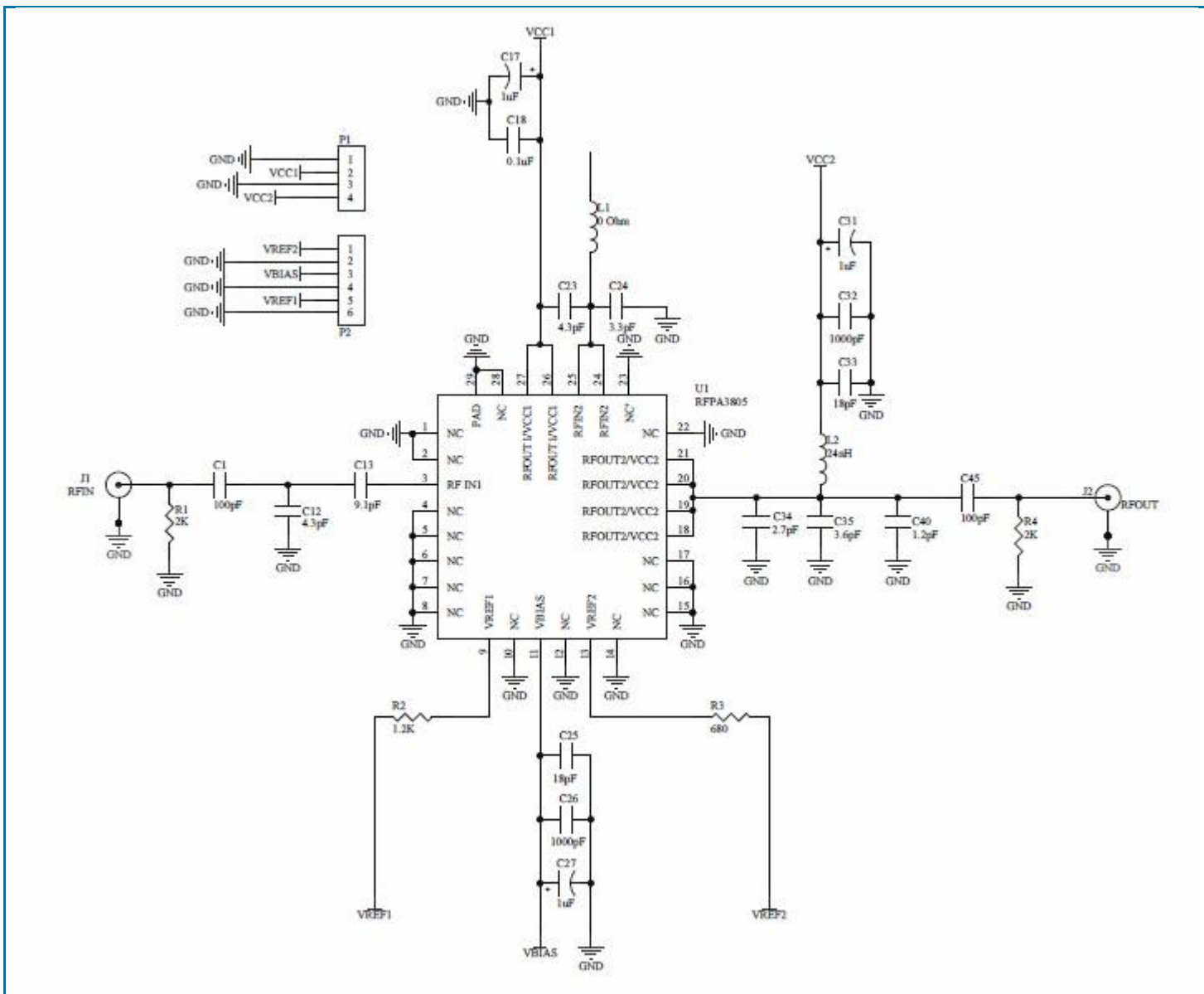

Evaluation Board Bill of Materials (BOM) 2110MHz to 2170MHz Application Circuit

Description	Reference Designator	Manufacturer	Manufacturer's P/N
RFPA3805 Evaluation Board			RFPA3805-410(A)
700MHz to 2700MHz, 2W, 5V, High Gain Linear PA in 4mm x 5mm QFN	U1	RFMD	RFPA3805
CAP, 100pF, 5%, 50V, C0G, 0402	C1, C45	Murata Electronics	GRM1555C1H101JA01D
CAP, 4.3pF, +/-0.1pF, 50V, C0G, 0402	C12, C23	Murata Electronics	GRM1555C1H4R3BA01D
CAP, 9.1pF, +/-0.25pF, 50V, HI-Q, 0402	C13	Murata Electronics	GJM1555C1H9R1CB01D
CAP, 1μF, 10%, 16V, X7R, 1206	C17, C27, C31	Murata Electronics	GRM31MR71E105KA01L
CAP, 0.1μF, 10%, 25V, X7R, 0603	C18	Kemet	C0603C104K3RAC
CAP, 3.3pF, +/-0.1pF, 50V, C0G, 0402	C24	Murata Electronics	GRM1555C1H3R3BA01D
CAP, 18pF, 5%, 50V, C0G, 0402	C25, C33	Murata Electronics	GRM1555C1H180JA01D
CAP, 1000pF, 10%, 50V, X7R, 0402	C26, C32	Murata Electronics	GRM155R71H102KA01D
CAP, 2.7pF, +/-0.1pF, 50V, HI-Q, 0402	C34	Murata Electronics	GJM1555C1H2R7BB01D
CAP, 3.6pF, +/-0.1pF, 50V, HI-Q, 0402	C35	Murata Electronics	GJM1555C1H3R6BB01D
CAP, 1.2pF, +/-0.25pF, 50V, HI-Q, 0402	C40	Murata Electronics	GJM1555C1H1R2CB01D
CONN, SMA, 4-HOLE PANEL MOUNT JACK	J1-J2	Gigalane Co., Ltd.	PA-S00-000
RES, 0Ω, 0402 KAMAYA	L1	Kamaya, Inc.	RMC1/16SJPTH
IND, 24nH, 5%, W/W, 0603	L2	Coilcraft	0603HC-24NXJLW
CONN, HDR, ST, PLRZD, 4-PIN, 0.100"	P1	ITW Pancon	MPSS100-4-C
CONN, HDR, St, PLRZD, 6-PIN, 0.100"	P2	ITW Pancon	MPSS100-6-C
RES, 2K, 5%, 1/6W, 0402	R1, R4	Kamaya, Inc.	RMC1/16S-202JTH
RES, 1.2K, 5%, 1/6W, 0402	R2	Kamaya, Inc.	RMC1/16S-122JTH
RES, 680Ω, 5%, 1/6W, 0402	R3	Kamaya, Inc.	RMC1/16S-681JTH
HEATSINK, BLOCK, TEST FIX, 1.5" x 2.0"			EEF-101217
SCREW, 2-56 x 3/16", SOCKET HEAD	S1-S9	McMaster-Carr Supply Co.	92196A076

Evaluation Board Assembly Drawing 2110MHz to 2170MHz Application Note

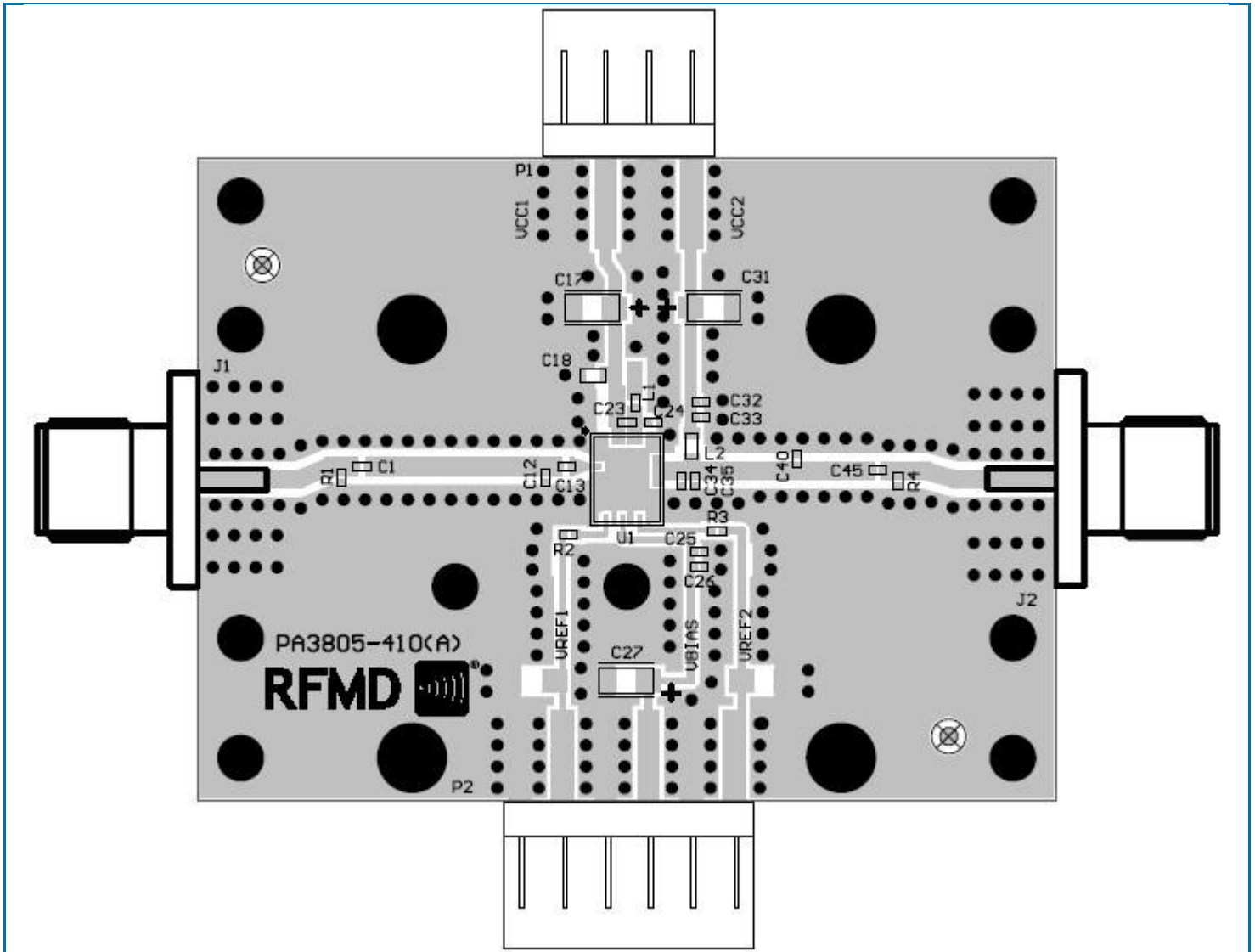

Typical Performance: $V_{CC1} = V_{CC2} = V_{BIAS} = 5V$, $V_{REF1} = V_{REF2} = 5V$
 (2580MHz to 2690MHz Application Circuit)

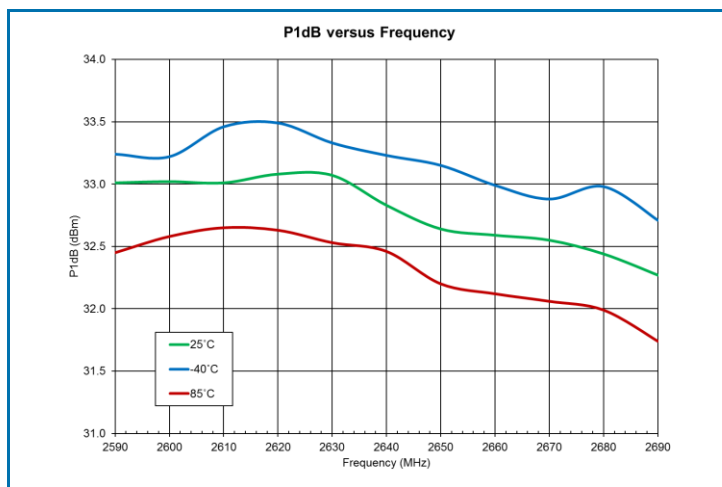
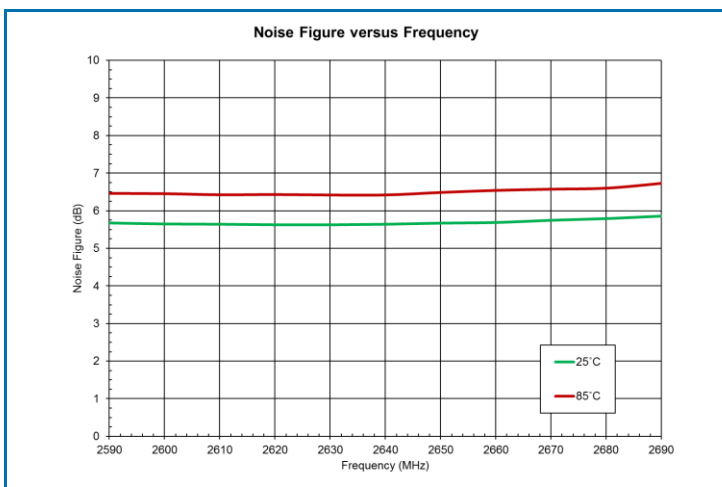
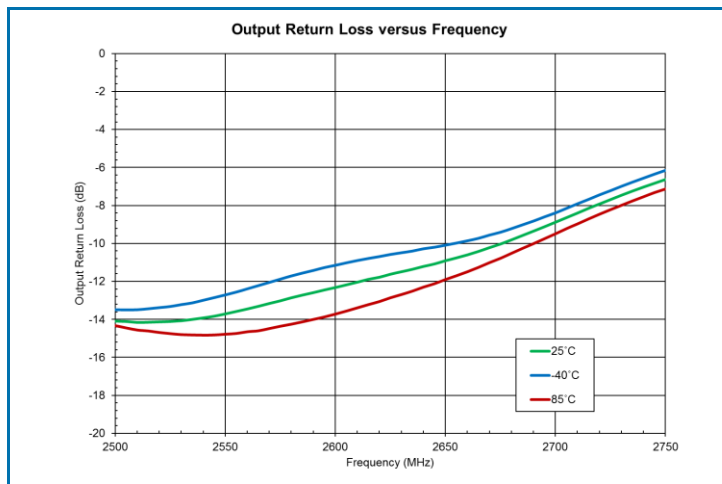
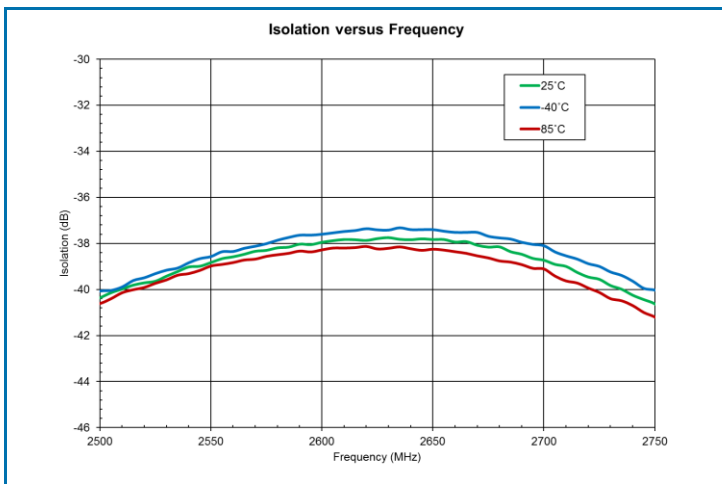
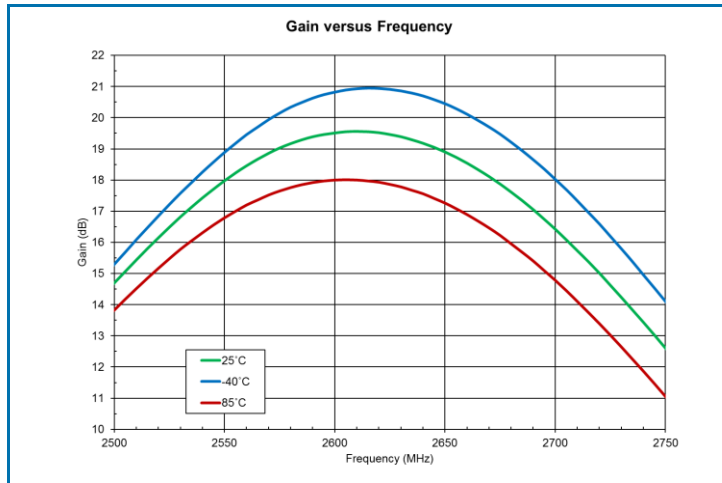
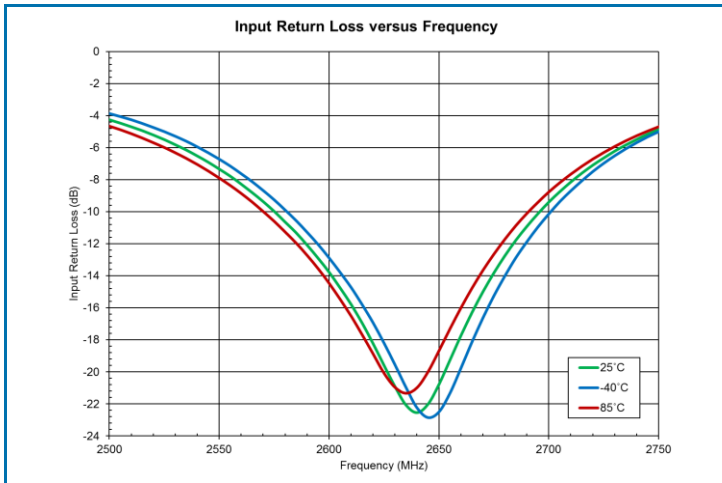

Typical Performance: $V_{CC1} = V_{CC2} = V_{BIAS} = 5V$, $V_{REF1} = V_{REF2} = 5V$
 (2580MHz to 2690MHz Application Circuit)

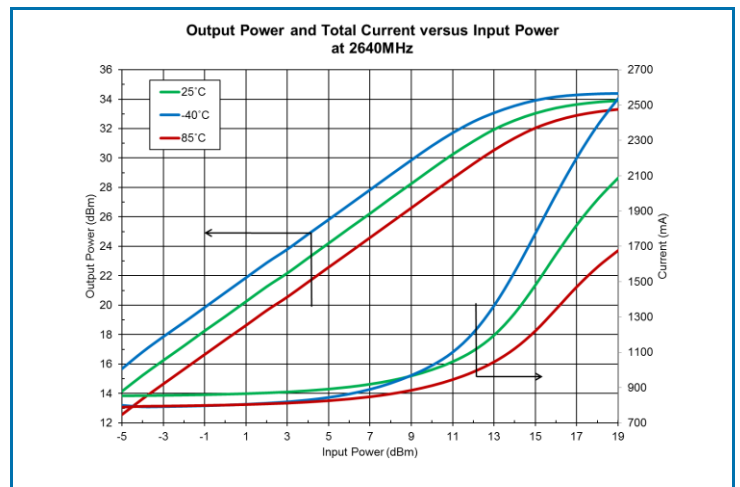
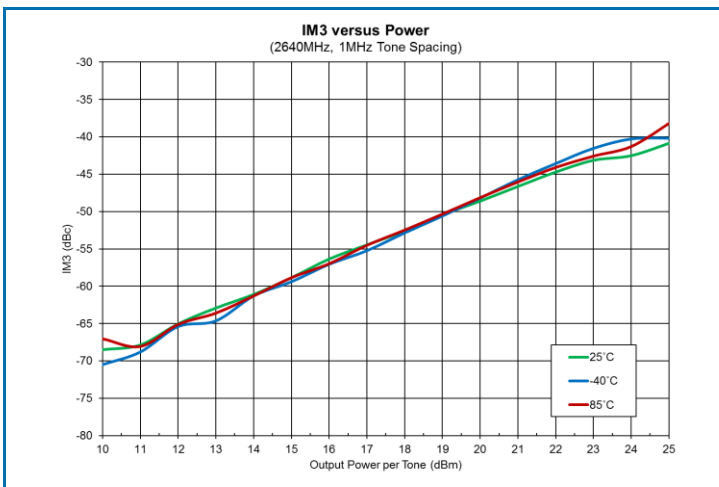
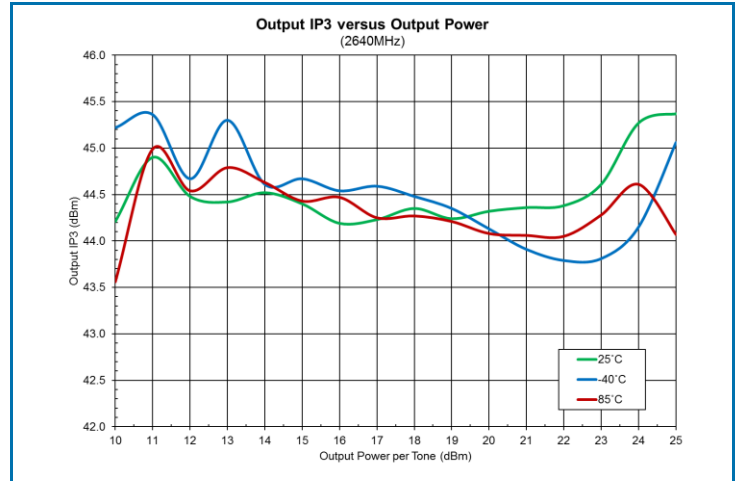
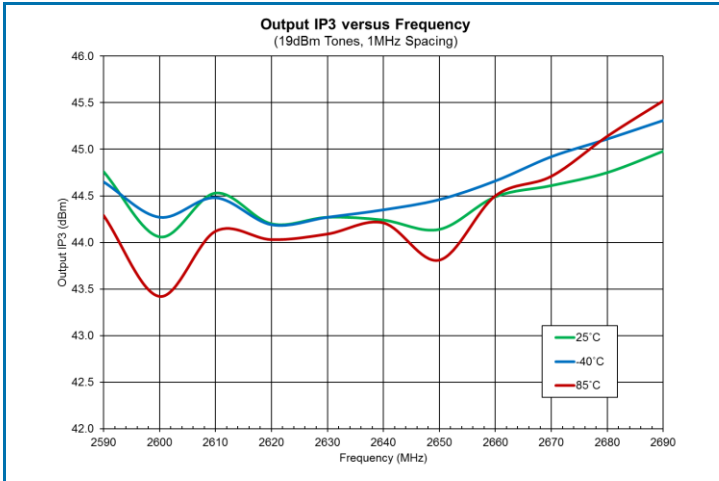
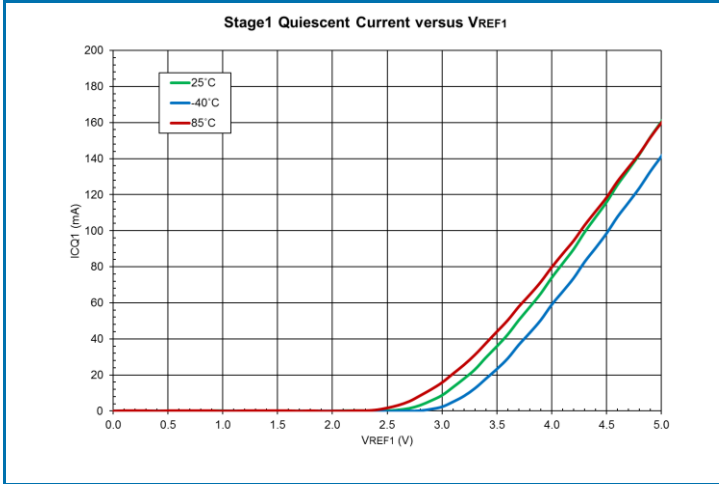

Typical Performance: $V_{CC1} = V_{CC2} = V_{BIAS} = 5V$, $V_{REF1} = V_{REF2} = 5V$
 (2580MHz to 2690MHz Application Circuit)

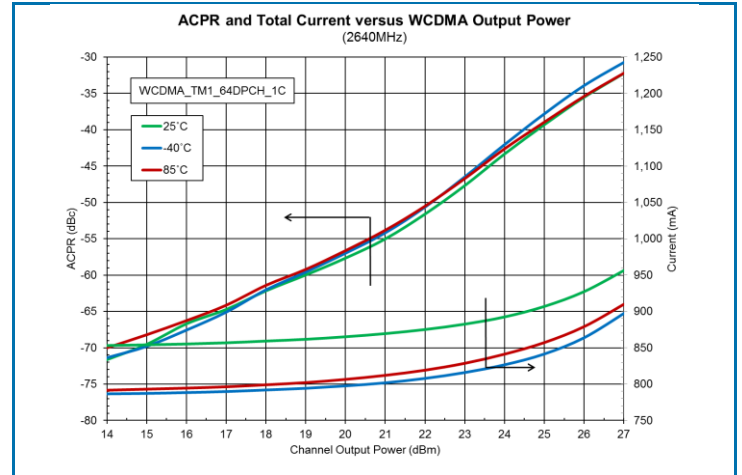
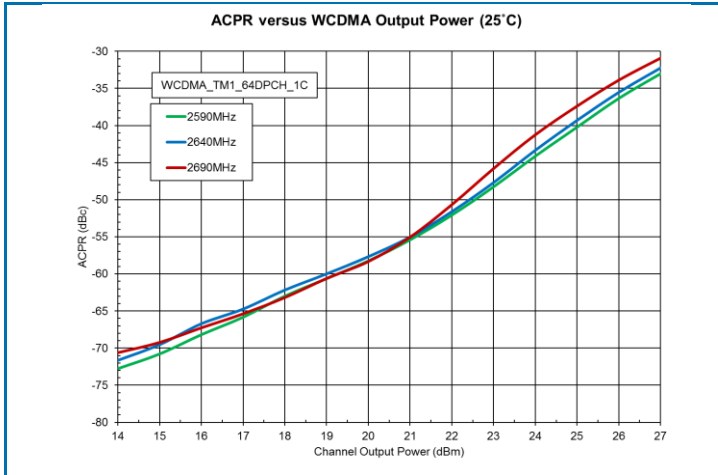

Evaluation Board Schematic 2580MHz to 2690MHz Application Circuit

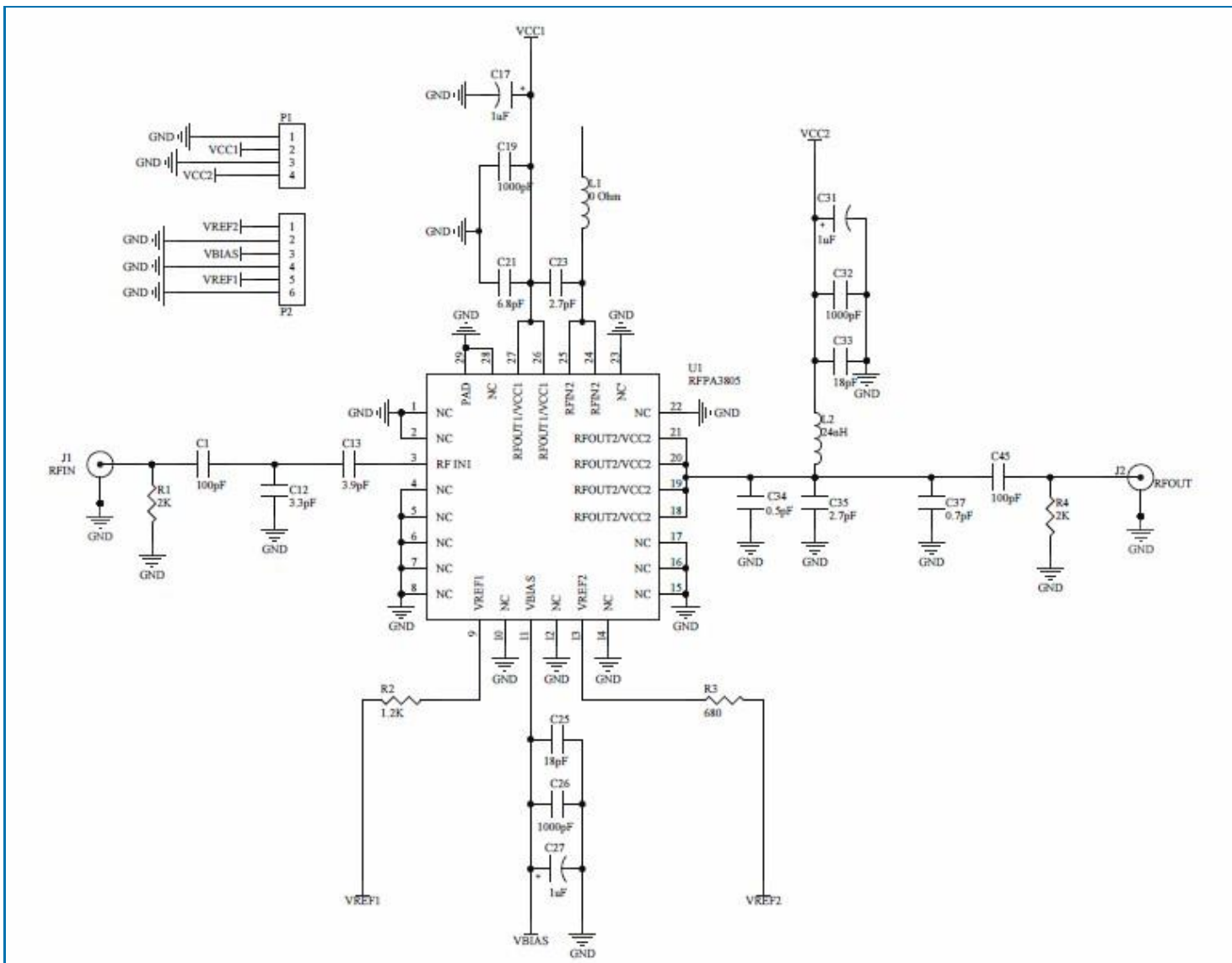

Evaluation Board Bill of Materials (BOM) 2580MHz to 2690MHz Application Circuit

Description	Reference Designator	Manufacturer	Manufacturer's P/N
RFPA3805 Evaluation Board			RFPA3805-410(A)
700MHz to 2700MHz, 2W, 5V, High Gain Linear PA in 4mm x 5mm QFN	U1	RFMD	RFPA3805
CAP, 100pF, 5%, 50V, C0G, 0402	C1, C45	Murata Electronics	GRM1555C1H101JA01D
CAP, 3.3pF, +/-0.1pF, 50V, HI-Q, 0402	C12	Murata Electronics	GJM1555C1H3R3BB01D
CAP, 3.9pF, +/-0.1pF, 50V, HI-Q, 0402	C13	Murata Electronics	GJM1555C1H3R9BB01D
CAP, 1μF, 10%, 16V, X7R, 1206	C17, C27, C31	Murata Electronics	GRM31MR71E105KA01L
CAP, 1000pF, 10%, 25V, X7R, 0402	C19	Murata Electronics	GRM155R71H102KA01D
CAP, 6.8pF, +/-0.25pF, 50V, HI-Q, 0402	C21	Murata Electronics	GJM1555C1H6R8CB01D
CAP, 2.7pF, +/-0.1pF, 50V, HI-Q, 0402	C23	Murata Electronics	GJM1555C1H2R7BB01D
CAP, 18pF, 5%, 50V, C0G, 0402	C25, C33	Murata Electronics	GJM1555C1H180JA01D
CAP, 1000pF, 10%, 50V, X7R, 0402	C26, C32	Murata Electronics	FRM155R71H102KA01D
CAP, 0.5pF, +/-0.05pF, 50V, HI-Q, 0402	C34	Murata Electronics	GJM1555C1HR50WB01D
CAP, 2.7pF, +/-0.1pF, 50V, HI-Q, 0402	C35	Murata Electronics	GJM1555C1H2R7BB01D
CAP, 0.7pF, +/-0.05, 50V, HI-Q, 0402	C37	Murata Electronics	GJM1555C1H70WB01D
CONN, SMA, 4-HOLE PANEL MOUNT JACK	J1-J2	Gigalane Co., Ltd.	PA-S00-000
RES, 0Ω, 0402 KAMAYA	L1	Kamaya, Inc.	RMC1/16SJPTH
IND, 24nH, 5%, W/W, 0603	L2	Coilcraft	0603HC-24NXJLW
CONN, HDR, ST, PLRZD, 4-PIN, 0.100"	P1	ITW Pancon	MPSS100-4-C
CONN, HDR, St, PLRZD, 6-PIN, 0.100"	P2	ITW Pancon	MPSS100-6-C
RES, 2K, 5%, 1/6W, 0402	R1, R4	Kamaya, Inc.	RMC1/16S-202JTH
RES, 1.2K, 5%, 1/6W, 0402	R2	Kamaya, Inc.	RMC1/16S-122JTH
RES, 680Ω, 5%, 1/6W, 0402	R3	Kamaya, Inc.	RMC1/16S-681JTH
HEATSINK, BLOCK, TEST FIX, 1.5" x 2.0"			EEF-101217
SCREW, 2-56 x 3/16", SOCKET HEAD	S1-S9	McMaster-Carr Supply Co.	92196A076

Evaluation Board Assembly Drawing 2580MHz to 2690MHz Application Note

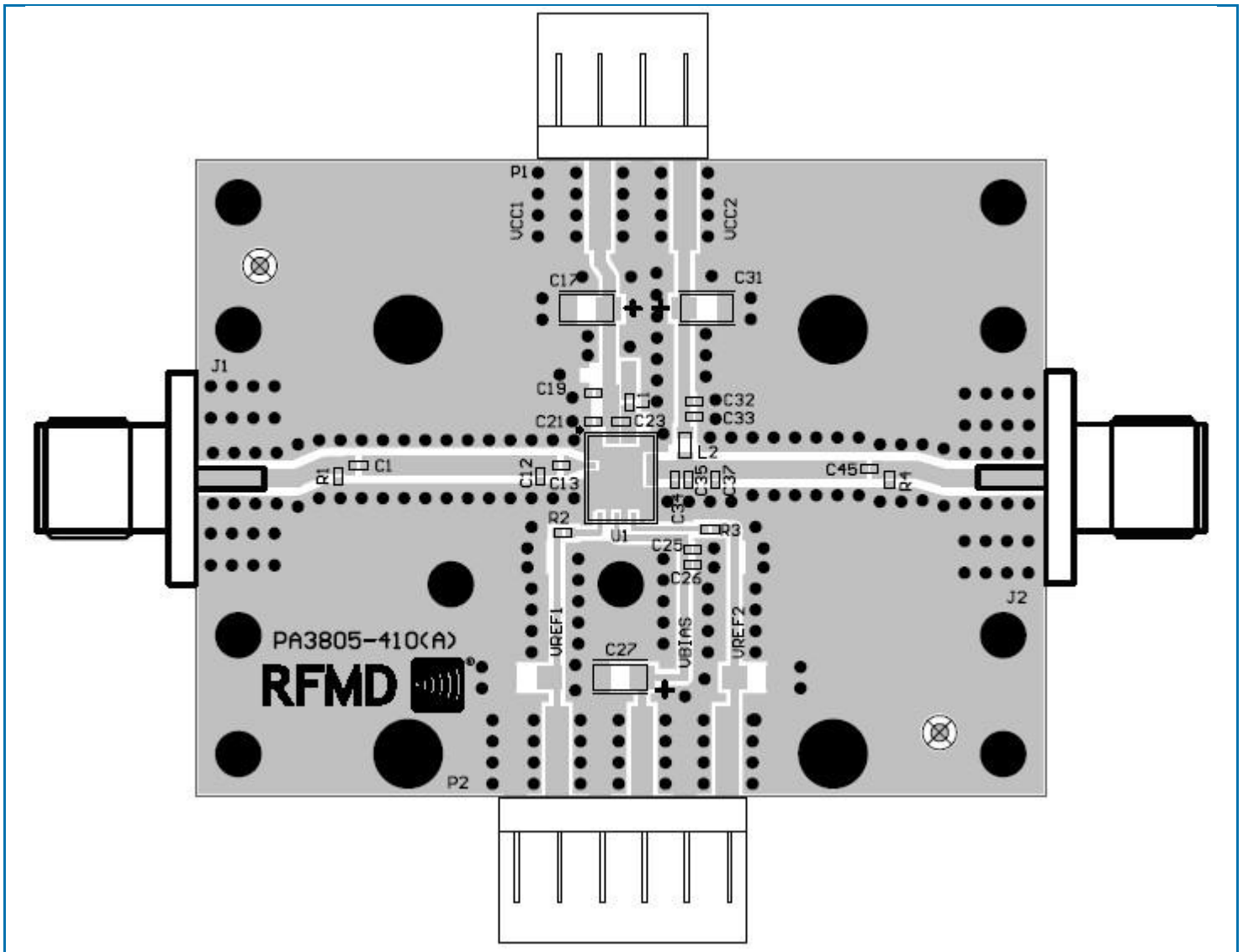

Pin Names and Descriptions

Pin	Name	Description
1	NC	No internal connection. EVB can be ground or no connect.
2	NC	No internal connection. EVB can be ground or no connect.
3	RFIN1	RF Input for stage 1, must be DC blocked
4	NC	No internal connection. EVB can be ground or no connect.
5	NC	No internal connection. EVB can be ground or no connect.
6	NC	No internal connection. EVB can be ground or no connect.
7	NC	No internal connection. EVB can be ground or no connect.
8	NC	No internal connection. EVB can be ground or no connect.
9	VREF1	Stage 1 V_{REF} . Can also be used as a stage 1 power-down pin.
10	NC	No internal connection. EVB can be ground or no connect.
11	VBIAS	Amplifiers V_{BIAS} pin
12	NC	No internal connection. EVB can be ground or no connect.
13	VREF2	Stage 2 V_{REF} . Can also be used as a stage 2 power-down pin.
14	NC	No internal connection. EVB can be ground or no connect.
15	NC	No internal connection. EVB can be ground or no connect.
16	NC	No internal connection. EVB can be ground or no connect.
17	NC	No internal connection. EVB can be ground or no connect.
18	RFOUT2/VCC2	RF output and collector supply for stage 2
19	RFOUT2/VCC2	RF output and collector supply for stage 2
20	RFOUT2/VCC2	RF output and collector supply for stage 2
21	RFOUT2/VCC2	RF output and collector supply for stage 2
22	NC	No internal connection. EVB can be ground or no connect.
23	NC	No internal connection. EVB can be ground or no connect.
24	RFIN2	RF input for stage 2, must be DC blocked
25	RFIN2	RF input for stage 2, must be DC blocked
26	RFOUT1/VCC1	RF output and collector supply for stage 1
27	RFOUT1/VCC1	RF output and collector supply for stage 1
28	NC	No internal connection. EVB can be ground or no connect.
EPAD	GND	DC and RF ground. Must be soldered to EVB ground plate over a bed of vias for thermal and RF performance. Solder/Epoxy voids under the EPAD will result in excessive junction temperature causing permanent damage.

Package Outline Drawing (Dimensions in millimeters)

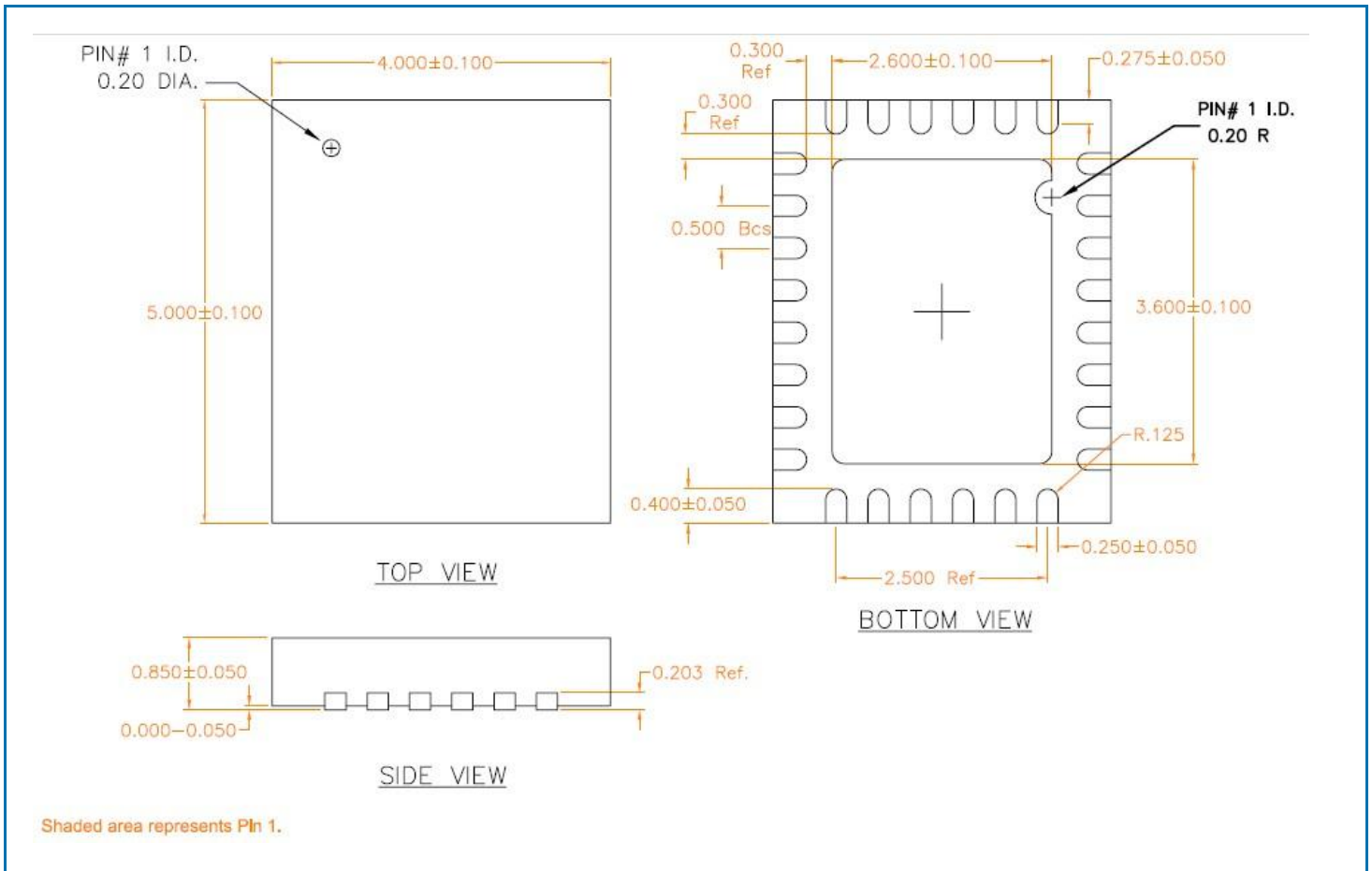

Branding Diagram

