

SHWA12C SERIES



12W Wall Mount Power Supply for Medical Equipment

- Wide Input Voltage 90 to 264 VAC, 47 to 63Hz
- European type 2 prong plug
- Output Voltage Available From 5VDC Thru 27VDC
- Single Output
- Over Load Protection.
- Class II Insulation

2 Year Warranty

Approvals:     **CBC ELPS**  

Single Output

Model Number	Output Voltage	Max. Output Current	Total Regulation	Maximum Output Power
SHWA12C-S02	5 ~ 6 VDC	2.00 ~ 1.66 A	5%	10W
SHWA12C-S03	6 ~ 8 VDC	2.00 ~ 1.50 A	5%	12W
SHWA12C-S04 *	8 ~ 11 VDC	1.50 ~ 1.09 A	5%	12W
SHWA12C-S05 *	11 ~ 13 VDC	1.09 ~ 0.92 A	5%	12W
SHWA12C-S06 *	13 ~ 16 VDC	0.92 ~ 0.75 A	5%	12W
SHWA12C-S07 *	16 ~ 21 VDC	0.75 ~ 0.57 A	3%	12W
SHWA12C-S08 *	21 ~ 27 VDC	0.57 ~ 0.44 A	3%	12W

Mark "*" means approved by CEC level V.

Total Regulation is conditioned by below configuration

(S02~S04 AWG16/2C/4FT output cable)

(S05~S08: AWG18/2C/6FT output cable)

Electrical Characteristics

Parameter	Test Conditions	Min.	Typ.	Max.	Unit
Input Voltage	Operating Voltage	90		264	VAC
Input Frequency		47		63	Hz
Output Power Range	Vin=90 to 264VAC	0		12	W
Input Current (Low Line)	Io=Full load, Vin=115VAC		0.25	0.35	A
Input Current (High Line)	Io=Full load, Vin=230VAC		0.17	0.22	A
Low Line Inrush Current	Io=Full load, 25°C Cool start, Vin=115VAC		14	16	A
High Line Inrush Current	Io=Full load, 25°C Cool start, Vin=230VAC		28	30	A
Efficiency	Io=Full Load, Vin=230VAC	77.7			%
Line Regulation	Io=Full Load			1	%
Load Regulation	Vin=230VAC			5	%
Over Current Protection		110		150	%
Transient Response	Io=Full Load to Half Load, Vin=100VAC			4	mS
Hold-Up Time	Io=Full Load, Vin=110VAC	10			mS
Start Up Time	Io=Full Load, Vin=100VAC	0.3	1	2	S
Ripple & Noise(Peak to Peak)	Full Load, Vin=90VAC			1	%
Temperature Coefficient	All output	-0.04		0.04	%/°C
Thermal Shutdown* By Junction Temperature Controller	The parameter is not subject to production test-verified by design/characterization of integrated controller.	-25		130	°C

* As long as faulty conditions have been removed, the adaptor will automatically power up as usual.

Conditions

Parameter	Test Conditions	Min.	Typ.	Max.	Unit
Operating Temperature		0	40	70	°C
Storage Temperature		-40		85	°C
Relative Humidity	No-Condensing	5		95	%
Operating Temperature at 25°C, Calculated per MIL-HDBK-217F		0.1M			Hrs
De-rate linearly from 100 % load at 40°C to 50 % load at 70°C					

Approvals and Compliances

Parameter	Test Conditions	Min.	Unit
Dielectric Withstanding Voltage for Primary to secondary	Primary to secondary	5656	VDC
Meet EMI requirements: CISPR-11	Vin=220VAC	B	CLASS
Meet EMI requirements: FCC Part18	Vin=110VAC	B	CLASS

Mechanical and PIN out

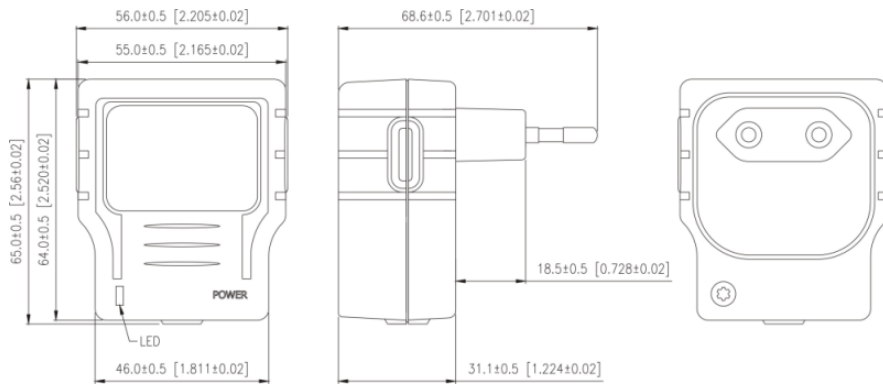

Note:

1. Dimensions are shown in mm & inch
2. Weight: approx. 140g
3. Optional output connector.