

# OV9770 720p HD product brief



## High-Performance OV9770 Sets New HD Camera Performance Standard for Notebook, Tablet and Entertainment Markets



available in  
a lead-free  
package

The 1/6-inch OV9770 is an advanced CMOS image sensor designed for high performance 720p/30 fps high definition (HD) video applications for the notebook, tablet and entertainment markets. It is the first HD image sensor to use the new 1.75-micron OmniBSI-2™ pixel, delivering the best low-light performance (SNR10) and the highest sensitivity and dynamic range in its class. The new OmniBSI-2 pixel architecture brings a 20 percent improvement in peak quantum efficiency, a 50 percent increase in full well capacity, and a 20 percent improvement in low-light performance, elevating the OV9770 to a new quality standard for HD video capture in 720p resolution.

A native 720p HD sensor, the OV9770 captures 30 frames per second (fps) in full 1280 x 720 resolution without losing image quality from degradation or image artifacts due to scaling or

cropping. Image quality is further improved by minimizing lighting and electrical sources of contamination such as fixed pattern noise and smearing to produce a clean, stable color image. All required image processing functions including exposure control and defective pixel canceling are programmable through the Serial Camera Control Bus (SCCB) interface. The sensor also provides full-frame, sub-sampled or windowed 8-bit/10-bit images in RAW through the SCCB interface.

The OV9770 supports multiple platform architectures and controllers with both parallel and MIPI interfaces, significantly reducing product development time.

Find out more at [www.ovt.com](http://www.ovt.com).

## Applications

- PC Multimedia
- Games
- Tablets
- Cellular and Picture Phones
- Toys

## Product Features

- 1.75  $\mu\text{m}$  OmniBSI-2™ pixel technology
- supports frame sync
- MIPI and D-PHY specification (contains one clock lane and one data lane) with a maximum of 400 Mbps data transfer rate
- low operating voltage and low power consumption for embedded portable applications
- supports free-running clock and gated clock
- supports down sample mode and VarioPixel\*
- supports global analog gain
- auto black level calibration
- high sensitivity and low dark current for low-light conditions
- defect pixel correction capability

# OV9770



## Ordering Information

- OV09770-G04A (color, chip probing, 200  $\mu\text{m}$  backgrinding, reconstructed wafer)

## Product Specifications

- active array size: 1280 x 720
- lens chief ray angle: 29.4°
- power supply:
  - core: 1.2V
  - analog: 2.8V
  - I/O: 1.8V
- input clock frequency: 6 - 27 MHz
- maximum image transfer rate: - 720p (1280x720): 30 fps
- power requirements:
  - active: 125 mA
- scan mode: progressive
- maximum exposure interval: 760 x  $t_{\text{row}}$
- temperature range:
  - operating: -30°C to 70°C junction temperature
  - stable image: 0°C to 50°C junction temperature
- pixel size: 1.75  $\mu\text{m}$  x 1.75  $\mu\text{m}$
- image area: 2296  $\mu\text{m}$  x 1295  $\mu\text{m}$
- output formats: 10-bit RAW RGB data
- die dimensions: 5000  $\mu\text{m}$  x 2800  $\mu\text{m}$
- lens size: 1/6.5"

## Functional Block Diagram

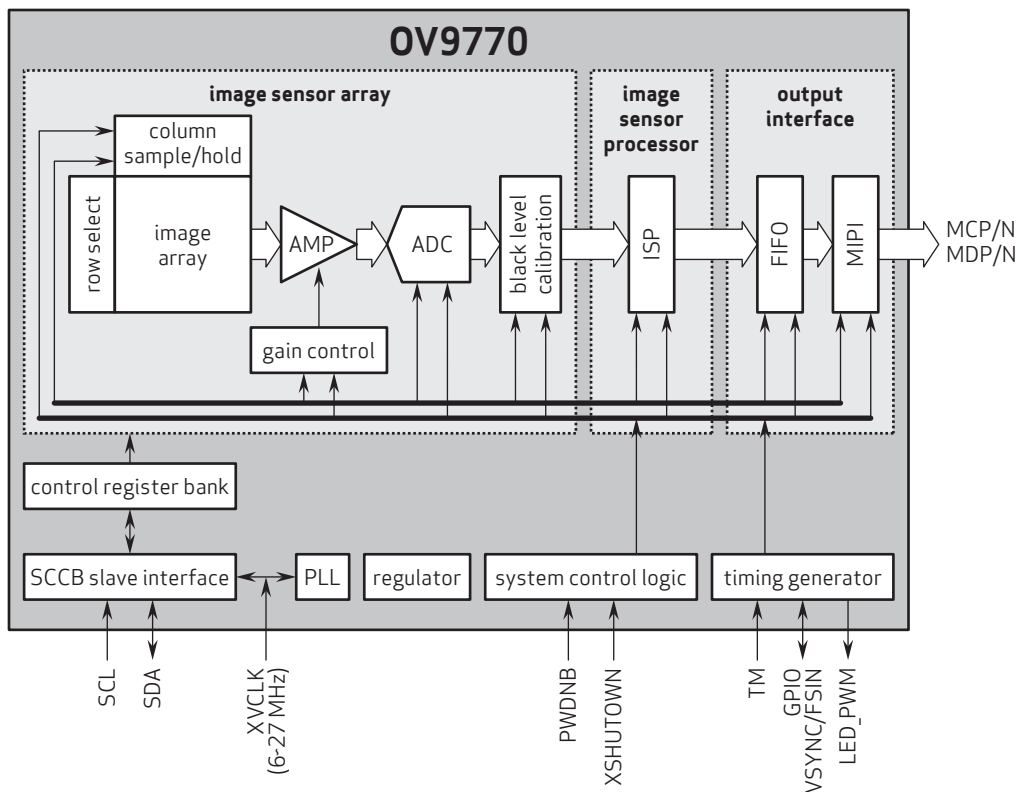

4275 Burton Drive  
Santa Clara, CA 95054  
USA

Tel: + 1 408 567 3000  
Fax: + 1 408 567 3001  
www.ovt.com

OmniVision reserves the right to make changes to their products or to discontinue any product or service without further notice. OmniVision, the OmniVision logo, OmniPixel and VarioPixel are registered trademarks of OmniVision Technologies, Inc. OmniBSI-2 is a trademark of OmniVision Technologies, Inc. All other trademarks are the property of their respective owners.

