

16-Channel Serial to Parallel Converter with High Voltage Backplane Driver and Push-Pull Outputs

Features

- ▶ HVCMOS® technology
- ▶ Output voltage up to +200V
- ▶ Shift register speed 500kHz @ $V_{DD} = 2.0V$
- ▶ 16 high voltage outputs
- ▶ High voltage backplane driver
- ▶ CMOS input levels

Applications

- ▶ Multiple segment EL display
- ▶ Piezoelectric transducer driver
- ▶ Braille driver

General Description

The HV509 is a 200V, 16-channel serial to parallel converter. The high voltage outputs and the backplane driver are designed to source and sink $\pm 1.0mA$.

The high voltage outputs are controlled by a 16-bit serial shift register, followed by a 16-bit latch. Data is shifted through the shift registers during the low to high clock transition. A data output buffer is provided for cascading multiple devices. Data is transferred to the 16-bit latch when a logic level low is applied to the \overline{LE} input. Data is stored in the latch when \overline{LE} is high. Output states are controlled by the data in the latch and by the POL pin.

Typical Application Circuit

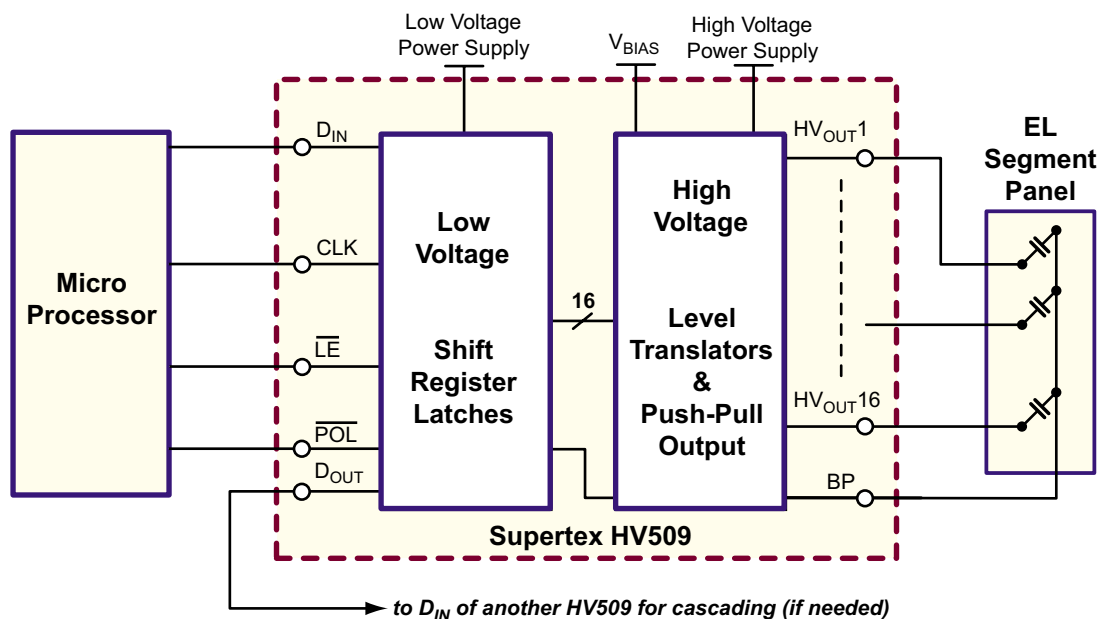

Ordering Information

| Device | Package Option |
|--------|---|
| | 32-Lead QFN 5.00x5.00mm body 1.00mm height (max) 0.50mm pitch |
| HV509 | HV509K6-G |

-G indicates package is RoHS compliant ("Green")



Pin Configuration

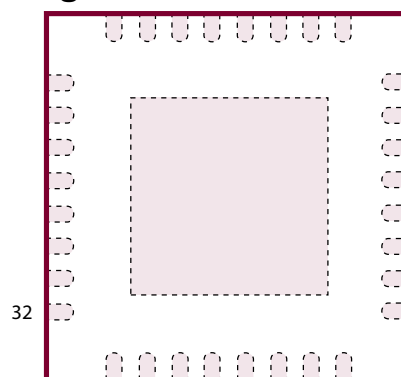

1 32-Lead QFN
(top view)

Pads are at the bottom of the package.
Exposed heat slug is at V_{PP} potential.

Absolute Maximum Ratings

| Parameter | Value |
|--|---------------------------------|
| Logic supply, V _{DD} | -0.5V to 7.0V |
| High voltage supply, V _{PP} | 215V |
| Translator supply voltage, V _{BIAS} | -0.5V to 7.0V |
| Logic input levels | -0.5V to V _{DD} + 0.5V |
| Operating junction temperature | -40°C to +125°C |
| Storage temperature range | -65°C to +150°C |

Absolute Maximum Ratings are those values beyond which damage to the device may occur. Functional operation under these conditions is not implied. Continuous operation of the device at the absolute rating level may affect device reliability. All voltages are referenced to device ground.

Product Marking

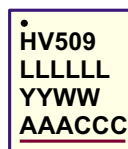

L = Lot Number
 YY = Year Sealed
 WW = Week Sealed
 A = Assembler ID
 C = Country of Origin
 — = "Green" Packaging

32-Lead QFN (K6)

Operating Supply Voltages and Conditions

| Sym | Parameter | Min | Typ | Max | Units | Conditions |
|-------------------|---------------------------------|--------------------|-----|--------------------|-------|------------|
| V _{DD} | Logic supply voltage | 2.0 | 3.0 | 5.5 | V | --- |
| V _{BIAS} | Level translator supply voltage | 2.6 | - | 6.6 | V | --- |
| V _{PP} | Positive high voltage supply | 50 | - | 200 | V | --- |
| V _{IH} | High-level input voltage | 0.9V _{DD} | - | V _{DD} | V | --- |
| V _{IL} | Low-level input voltage | 0 | - | 0.1V _{DD} | V | --- |
| T _A | Operating temperature | 0 | - | +70 | °C | --- |

Notes:

- External ground noise reduction circuit will be provided by design upon characterization.
- Power-up sequence should be the following*:
 - Apply ground
 - Apply V_{DD}
 - Set all inputs (D_{IN}, CLK, LE, POL) to a known state
 - Apply V_{BIAS}
 - Apply V_{PP}
- Power-down sequence should be the reverse of the above.

*This power up sequence requires an external high voltage diode between VDD and VPP. Without the diode, power up VPP to a VDD level first to bias the silicon substrate. After all other signals are powered, finish raising the V_{PP} to its final level.

DC Electrical Characteristics (Over operating supply voltages and temperature, unless otherwise noted)

| Sym | Parameter | Min | Typ | Max | Units | Conditions | |
|-------------|-----------------------------------|------------------------|------------------|-----|---------|--|--|
| I_{DD} | V_{DD} supply current | - | - | 1.0 | mA | $f_{CLK} = 500kHz$ | |
| I_{DDQ} | Quiescent V_{DD} supply current | - | - | 10 | μA | All logic inputs = V_{DD} or 0V | |
| I_{BIAS} | V_{BIAS} supply current | - | - | 100 | μA | All HV _{OUTS} switching at 1kHz. Peak $I_{BIAS} = 200mA$ with all channels switching | |
| I_{BIASQ} | Quiescent V_{BIAS} current | - | - | 10 | μA | No HV _{OUT} switching | |
| I_{PPQ} | Quiescent V_{PP} supply current | - | - | 100 | μA | $V_{PP} = 200V$, outputs are static | |
| I_{IH} | High-level logic input current | - | - | 10 | μA | $V_{IH} = V_{DD}$ | |
| I_{IL} | Low-level logic input current | - | - | -10 | μA | $V_{IL} = 0V$ | |
| V_{OH} | High level output | HV _{OUT} & BP | $V_{PP} - 12V$ | - | - | V | IHV _{OUT} = -1.0mA, $V_{PP} = +200V$ |
| | | | $V_{PP} - 12V$ | -- | - | V | IHV _{OUT} = -1.0mA, $V_{PP} = +50V$ |
| | | D _{OUT} | $V_{DD} - 1.0V$ | - | - | V | ID _{OUT} = -1.0mA |
| V_{OL} | Low level output | HV _{OUT} & BP | - | - | 12 | V | IHV _{OUT} = 1.0mA, $V_{BIAS} = 5.4V$, $V_{PP} = +50$ to $+200V$ |
| | | | D _{OUT} | - | - | 1.0 | V |
| C_{DIN} | Logic input capacitance | - | - | 10 | pF | --- | |
| C_{DOUT} | Logic output capacitance | - | - | 10 | pF | --- | |

AC Electrical Characteristics (Over operating supply voltages and temperature, unless otherwise noted)

| Sym | Parameter | Min | Typ | Max | Units | Conditions |
|-----------|--|---------------------------|-----|-----|---------|---|
| f_{CLK} | Clock frequency | 0 | - | 500 | kHz | --- |
| t_C | Clock high / low pulse width | 1.0 | - | - | μs | --- |
| t_{SU} | Data setup time before clock rises | 50 | - | - | ns | --- |
| t_H | Data hold time after clock rises | 50 | - | - | ns | --- |
| t_{CLE} | \overline{LE} from CLK setup time | 15 | - | - | ns | --- |
| t_{WLE} | \overline{LE} pulse width | 100 | - | - | ns | --- |
| t_{DD} | Clock negative edge to D _{OUT} delay | - | - | 150 | ns | $C_{LDOUT} = 50pF$, (C_{LDOUT} includes C_{DIN} and C_{DOUT}) |
| t_{PHV} | Delay time from inputs for HV _{OUT} / BP to start rise/fall | - | - | 500 | ns | $V_{PP} = 200V$, $V_{BIAS} = 5.4V$ |
| t_{OR} | HV _{OUTPUT} / BP rise time | - | - | 300 | μs | $C_L = 1500pF$, $V_{PP} = 200V$ |
| t_{OF} | HV _{OUTPUT} / BP fall time | - | - | 300 | μs | $C_L = 1500pF$, $V_{BIAS} = 5.4V$, $V_{PP} = 200V$ |
| t_{OC} | Width of \overline{POL} pulses | $t_{PHV} + t_{OR}/t_{OF}$ | - | - | μs | --- |

Input and Output Equivalent Circuits

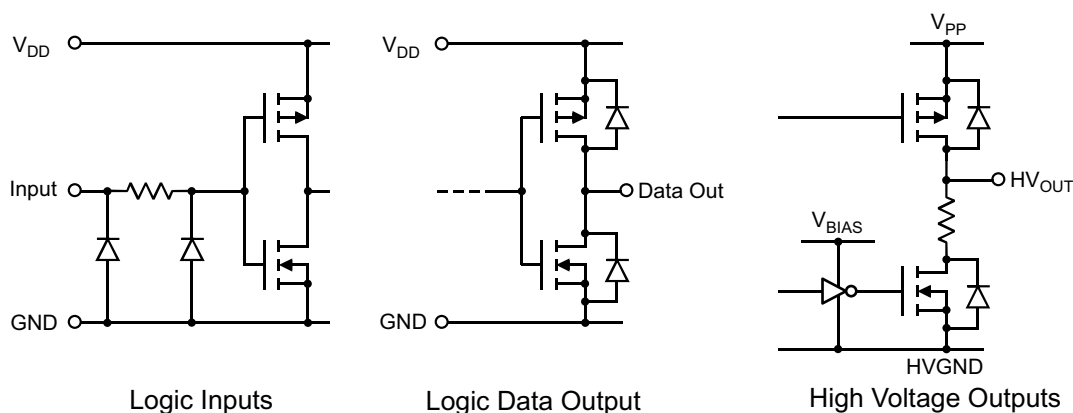

V_{BIAS} SUPPLY

The V_{BIAS} supply operates from 2.6V to 6.6V. It is the gate drive voltage for all of the output N-channel MOSFETs. This allows the output peak current sink to be set by varying the V_{BIAS} voltage. A higher V_{BIAS} voltage will increase the current sinking capability.

If large peak currents are not required, V_{DD} and V_{BIAS} can be connected to the same power supply, provided they are both within the operating range. The operating V_{DD} range is 2.0V to 5.5V. A plot showing the typical characteristics of I_{SINK} vs V_{BIAS} is shown below.

Typical HV_{OUT} I_{SINK} vs V_{BIAS}

(V_{PP} = 200V, C_{LOAD} = 1nF)

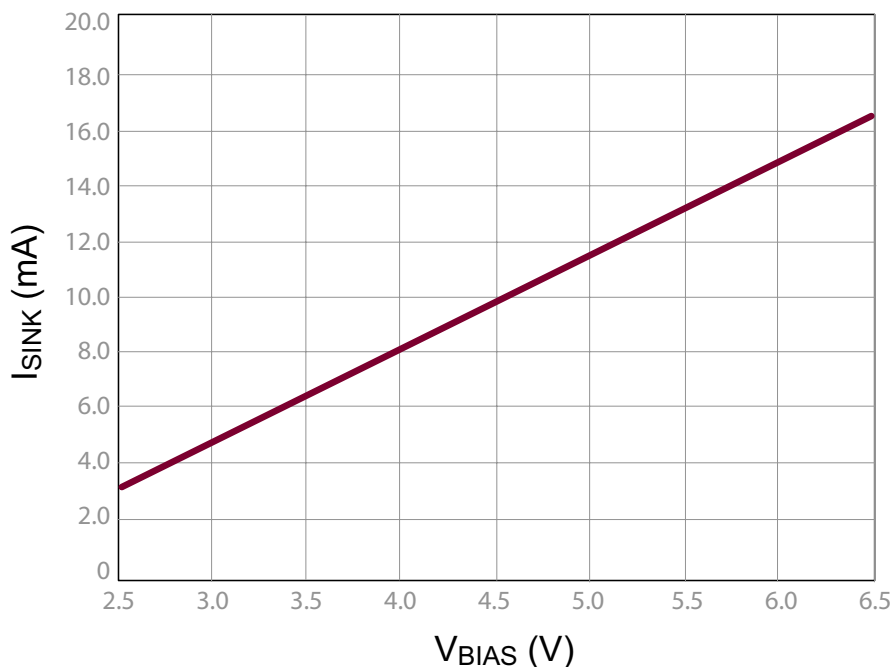

Switching Waveforms

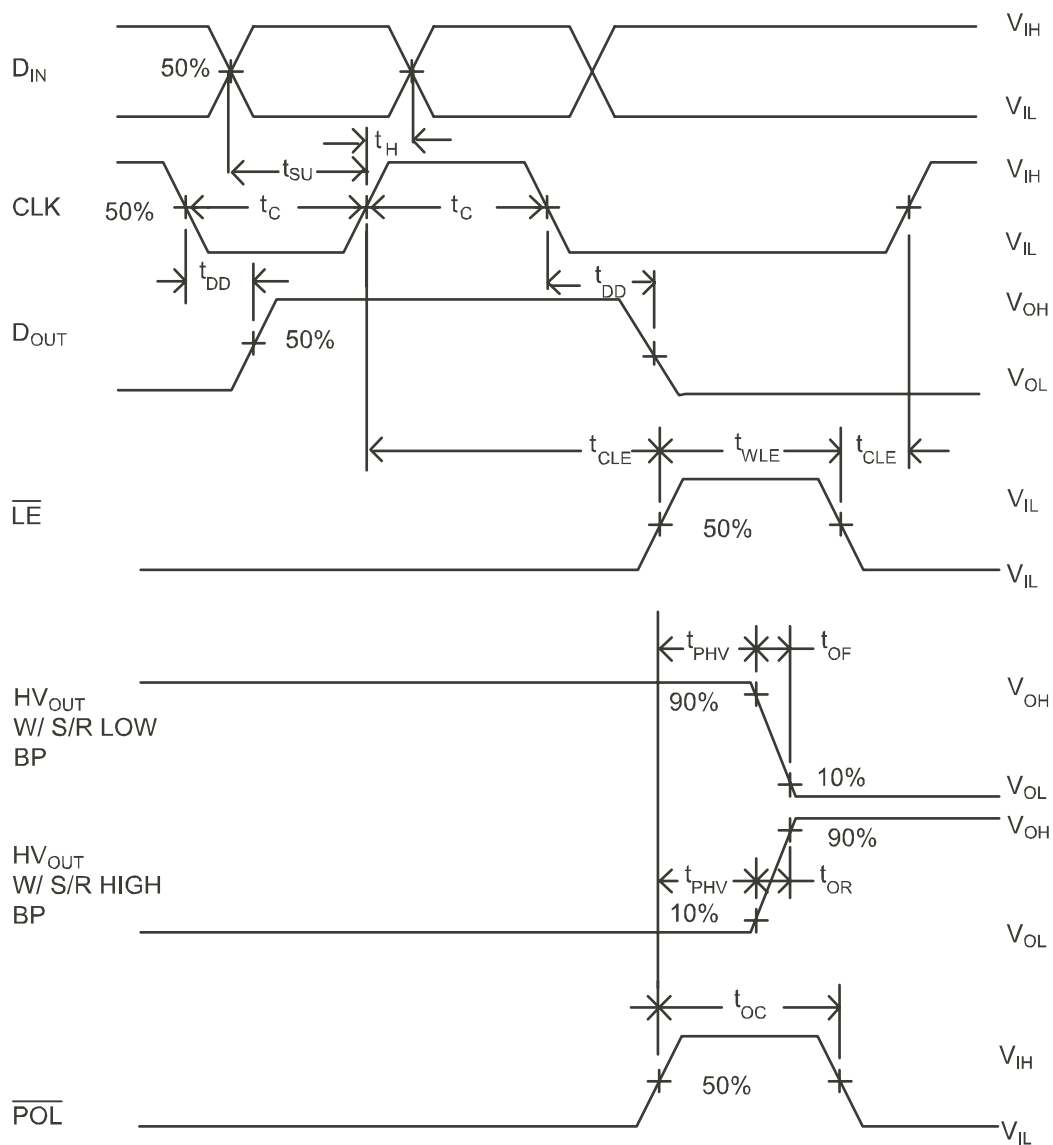

Functional Block Diagram

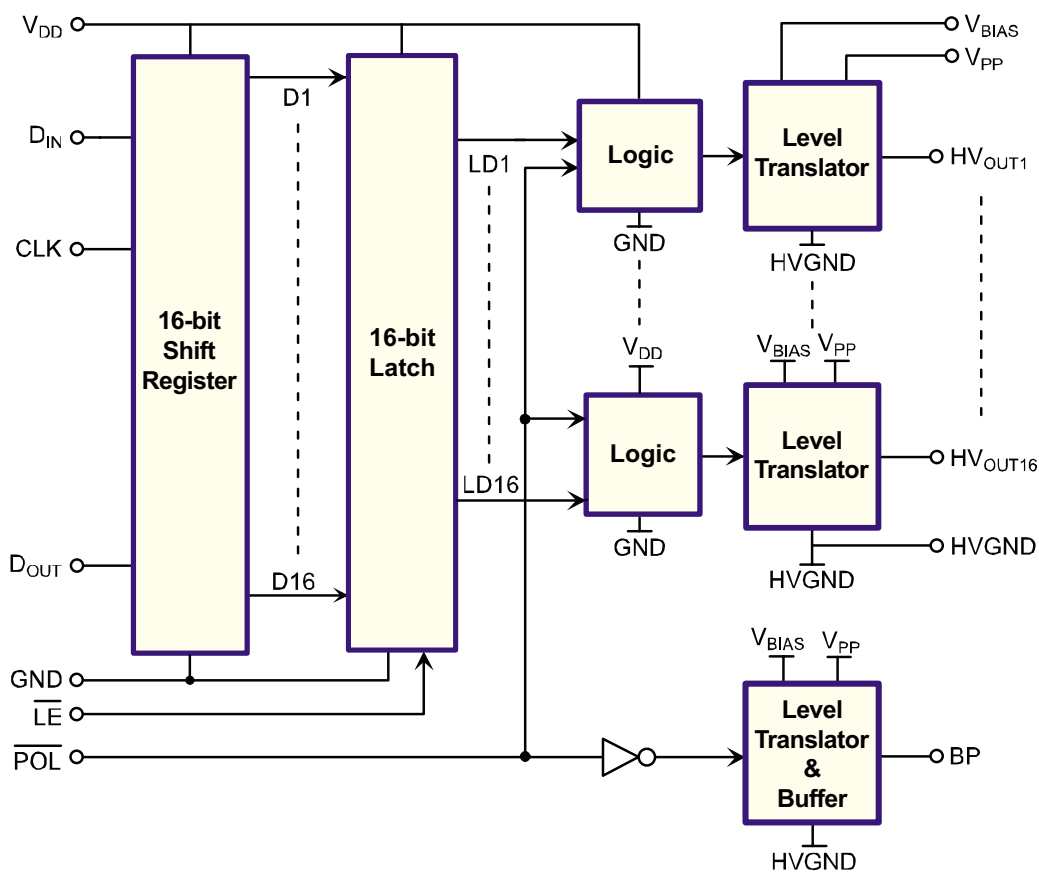

Function Table

| Function | Inputs | | | | Outputs | | | |
|------------------------|-----------------|-----|-----------------|------------------|-----------------------|------------------------|----|------------------|
| | D _{IN} | CLK | \overline{LE} | \overline{POL} | Shift Reg 1 2...16 | HV Outputs 1 2...16 | BP | D _{OUT} |
| Load S/R | H OR L | ↑ | H | X | H or L ●...● | ● ●...● | X | ● |
| Transfer data in latch | X | L | L | H | * *.....* | * *.....* | L | ● |
| | X | L | L | L | * *.....* | * *.....*(b) | H | ● |
| Store data in latches | X | X | H | H | ● ●...● | ● ●...● | L | ● |
| | X | X | H | L | ● ●...● | ● ●...●(b) | H | ● |
| Transparent mode | L | ↑ | L | H | L ●...● | L ●...● | L | ● |
| | H | ↑ | L | H | H ●...● | H ●...● | L | ● |
| Invert mode | X | X | H | L | ● ●...● | ● ●...●(b) | H | X |
| | X | X | H | H | ● ●...● | ● ●...● | L | X |

Notes:

- H = high level, L = low level, X = irrelevant, ↑ = low-to-high transition
- = dependent on previous stage's state before the last CLK or last \overline{LE} low
- * = data at the last CLK ↑
- (b) = bar over all symbols

Pin Description

| Pin # | Function | Description |
|-------|----------------------|-------------------------------|
| 1 | HV _{OUT} 12 | High voltage push-pull output |
| 2 | HV _{OUT} 11 | High voltage push-pull output |
| 3 | HV _{OUT} 10 | High voltage push-pull output |
| 4 | HV _{OUT} 9 | High voltage push-pull output |
| 5 | HV _{OUT} 8 | High voltage push-pull output |
| 6 | HV _{OUT} 7 | High voltage push-pull output |
| 7 | HV _{OUT} 6 | High voltage push-pull output |
| 8 | HV _{OUT} 5 | High voltage push-pull output |
| 9 | HV _{OUT} 4 | High voltage push-pull output |
| 10 | HV _{OUT} 3 | High voltage push-pull output |
| 11 | HV _{OUT} 2 | High voltage push-pull output |
| 12 | HV _{OUT} 1 | High voltage push-pull output |
| 13 | NC | No connect |
| 14 | VPP | High voltage supply |
| 15 | GND | Logic ground |
| 16 | NC | No connect |
| 17 | DIN | Data in |
| 18 | NC | No connect |
| 19 | CLK | Clock input logic |
| 20 | VDD | Logic supply voltage |
| 21 | \overline{POL} | Polarity bar input logic |
| 22 | \overline{LE} | Latch enable bar input logic |
| 23 | NC | No connect |
| 24 | DOUT | Data out |
| 25 | NC | No connect |
| 26 | VBIAS | Level translator bias voltage |
| 27 | HVGND | High voltage ground |
| 28 | BP | High voltage backplane output |
| 29 | HV _{OUT} 16 | High voltage push-pull output |
| 30 | HV _{OUT} 15 | High voltage push-pull output |
| 31 | HV _{OUT} 14 | High voltage push-pull output |
| 32 | HV _{OUT} 13 | High voltage push-pull output |

32-Lead QFN Package Outline (K6)

5.00x5.00mm body, 1.00mm height (max), 0.50mm pitch

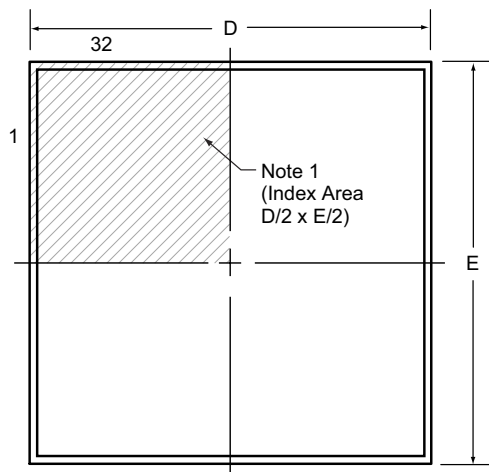

Top View

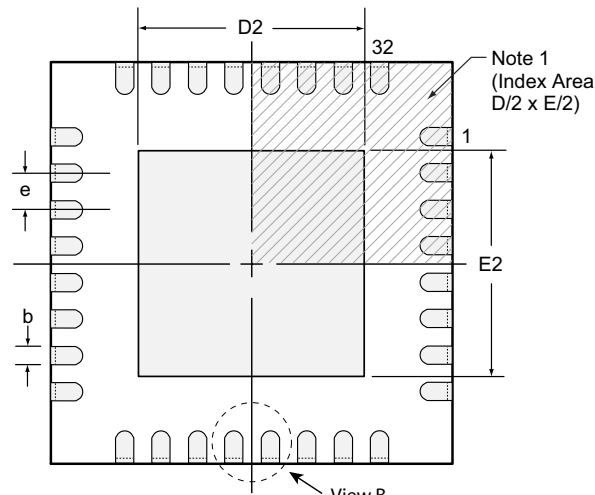

Bottom View

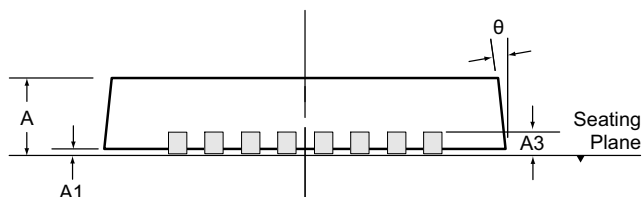

Side View

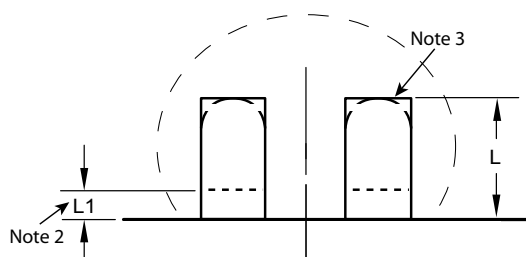

View B

Notes:

1. A Pin 1 identifier must be located in the index area indicated. The Pin 1 Identifier can be: a molded mark/identifier; an embedded metal marker; or a printed indicator.
2. Depending on the method of manufacturing, a maximum of 0.15mm pullback (L1) may be present.
3. The inner tip of the lead may be either rounded or square.

| Symbol | A | A1 | A3 | b | D | D2 | E | E2 | e | L | L1 | θ | |
|----------------|-----|------|------|----------|------|-------|-------------------|-------|-------------------|----------|-------------------|------|-----|
| Dimension (mm) | MIN | 0.80 | 0.00 | 0.20 REF | 0.18 | 4.85* | 1.05 | 4.85* | 1.05 | 0.50 BSC | 0.30 [†] | 0.00 | 0° |
| | NOM | 0.90 | 0.02 | | 0.25 | 5.00 | - | 5.00 | - | | 0.40 [†] | - | - |
| | MAX | 1.00 | 0.05 | | 0.30 | 5.15* | 3.55 [†] | 5.15* | 3.55 [†] | | 0.50 [†] | 0.15 | 14° |

JEDEC Registration MO-220, Variation VHHD-6, Issue K, June 2006.

* This dimension is not specified in the original JEDEC drawing. The value listed is for reference only.

† This dimension is a non-JEDEC dimension.

Drawings not to scale.

Supertex Doc. #: DSPD-32QFNK65X5P050, Version B090808.

(The package drawing(s) in this data sheet may not reflect the most current specifications. For the latest package outline information go to <http://www.supertex.com/packaging.html>.)

Supertex inc. does not recommend the use of its products in life support applications, and will not knowingly sell them for use in such applications unless it receives an adequate "product liability indemnification insurance agreement." Supertex inc. does not assume responsibility for use of devices described, and limits its liability to the replacement of the devices determined defective due to workmanship. No responsibility is assumed for possible omissions and inaccuracies. Circuitry and specifications are subject to change without notice. For the latest product specifications refer to the Supertex inc. website: <http://www.supertex.com>.