4 KEY TOUCH PAD DETECTOR IC

GENERAL DESCRIPTION

The TTP224N-ASD TonTouch™ IC is capacitive sensing design specifically for touch pad controls. The device built in regulator for touch sensor. Stable sensing method can cover diversity conditions. Human interfaces control panel links through non-conductive dielectric material. The main application is focused at replacing of the mechanical switch or button. The ASSP can independently handle the 4 touch pads with 4 direct output pins.

FEATURES

- Operating voltage 2.4V~5.5V
- Built-in regulator with external enable/disable option
- Operating current, @VDD=3V no load
At low power mode typical 2.5uA, At fast mode typical 9uA
- @VDD=3V operating voltage :
The response time about 60mS at fast mode,160mS at low power mode
- Sensitivity can adjust by the capacitance(0~50pF) outside for each touch pad
- Provides Fast mode and Low Power mode selection by pad option(LPMB pin)
- Provides direct mode or toggle mode 、CMOS output or open drain output 、active high or active low by pad option(TOG/OD/AHLB pin).
- Provides one output pin TPQ0D that has no diode protection, active low
- Have the maximum on time 120sec/64sec/16sec/infinite by pad option(MOT1, MOT0 pin)
- After power-on have about 0.5sec stable-time, during the time do not touch the key pad, and the function is disabled
- Auto calibration for life, and the re-calibration period is about 4.0sec, when key has not be touched.

APPLICATION

- Wide consumer products
- Button key replacement

BLOCK DIAGRAM

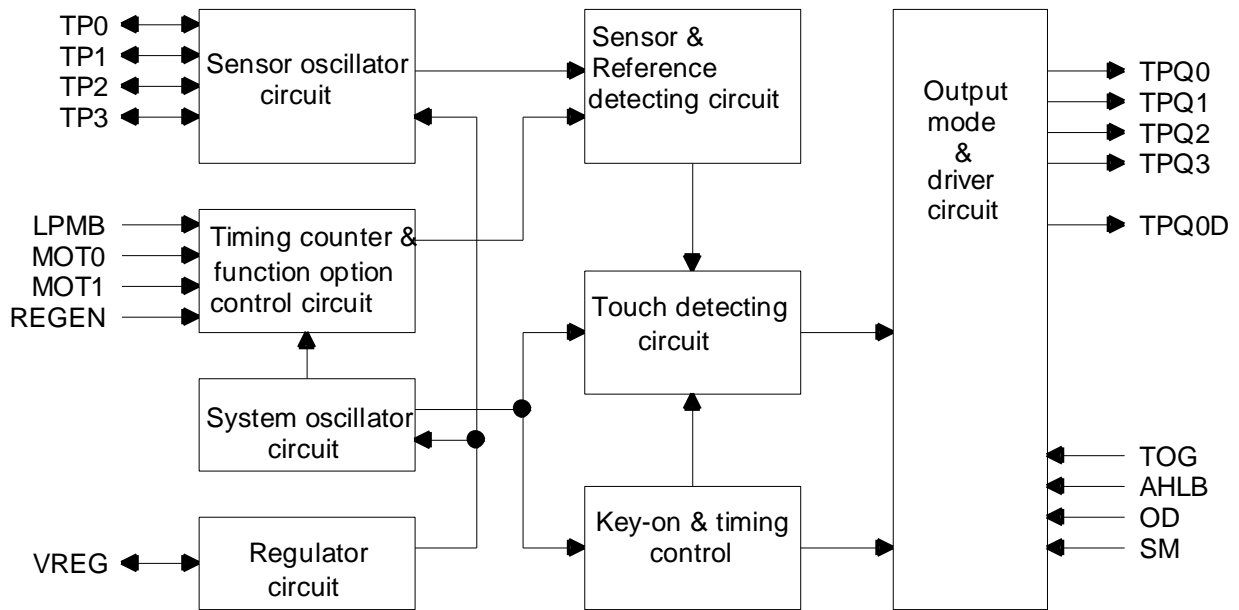

PACKAGE LIST

TTP224N-ASD package type is SSOP-20 ,package configuration is below

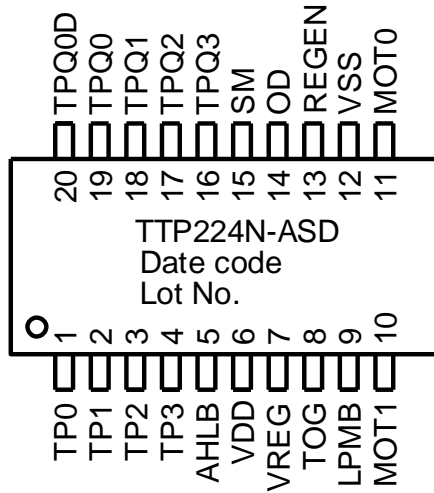

PIN DESCRIPTION

Pin No.	Pin Name	Type	Pad Description
1	TP0	I/O	Touch pad input pin
2	TP1	I/O	Touch pad input pin
3	TP2	I/O	Touch pad input pin
4	TP3	I/O	Touch pad input pin
5	AHLB	I-PL	Output active high or low option, default:0
6	VDD	P	Positive power supply
7	VREG	P	Internal regulator output pin
8	TOG	I-PL	Output type option, default:0
9	LPMB	I-PL	Low power/fast mode option, default:0
10	MOT1	I-PH	Key maximum on time option, default:1
11	MOT0	I-PH	
12	VSS	P	Negative power supply, ground
13	REGEN	I-PH	Internal regulator enable/disable function option, default:1
14	OD	I-PH	Output open-drain option, default:1
15	SM	I-PH	Single/multi key option, default:1
16	TPQ3	O	Direct output for TP3 touch input pin
17	TPQ2	O	Direct output for TP2 touch input pin
18	TPQ1	O	Direct output for TP1 touch input pin
19	TPQ0	O	Direct output for TP0 touch input pin
20	TPQ0D	OD	Open Drain output(have no Diode protective circuit), active low for TP0 touch input pin

Note : Pin Type

- I => CMOS input only
- I-PH => CMOS input and pull-high resistor
- I-PL => CMOS input and pull-low resistor
- O => CMOS push-pull output
- OD => Open drain output, have no Diode protective circuit
- I/O => CMOS I/O
- P => Power / Ground

ELECTRICAL CHARACTERISTICS

• **Absolute Maximum Ratings**

Parameter	Symbol	Conditions	RATING	Unit
Operating Temperature	Top	—	-40°C ~ +85°C	°C
Storage Temperature	T _{STG}	—	-50°C ~ +125°C	°C
Supply Voltage	VDD	Ta=25°C	VSS-0.3 ~ VSS+6.0	V
Input Voltage	V _{IN}	Ta=25°C	VSS -0.3 to VDD+0.3	V
Human Body Mode	ESD	—	5	KV

Note: VSS symbolizes for system ground

• **DC/AC Characteristics** : (Test condition at room temperature=25°C)

Parameter	Symbol	Test Condition	Min.	Typ.	Max.	Unit
Operating Voltage	VDD	Regulator disable	2.0		5.5	V
Operating Voltage	VDD	Regulator enable	2.4	-	5.5	V
Internal Regulator Output	VREG	Regulator enable	2.2	2.3	2.4	V
Operating Current (no load , regulator enable)	I_{op1}	VDD=3V, At low power mode		2.5		uA
		VDD=3V, At fast mode		9		uA
Input Ports	V_{IL}	Input Low Voltage	0	-	0.2	VDD
Input Ports	V_{IH}	Input High Voltage	0.8	-	1.0	VDD
Output Port Sink Current	I_{OL}	VDD=3V, V _{OL} =0.6V	-	8	-	mA
Output Port Source Current	I_{OH}	VDD=3V, V _{OH} =2.4V	-	-4	-	mA
Input Pin Pull-high Resistor	R_{PH}	VDD=3V,		30K		ohm
Input Pin Pull-low Resistor	R_{PL}	VDD=3V,		25K		ohm
Output Response Time	T_R	VDD=3V, At fast mode		60		mS
		VDD=3V, At low power mode		160		mS

FUNCTION DESCRIPTION

1. Sensitivity adjustment

The total loading of electrode size and capacitance of connecting line on PCB can affect the sensitivity. So the sensitivity adjustment must according to the practical application on PCB. The TTP224N-ASD offers some methods for adjusting the sensitivity outside.

1-1 by the electrode size

Under other conditions are fixed. Using a larger electrode size can increase sensitivity.

Otherwise it can decrease sensitivity. But the electrode size must use in the effective scope.

1-2 by the panel thickness

Under other conditions are fixed. Using a thinner panel can increase sensitivity. Otherwise it can decrease sensitivity. But the panel thickness must be below the maximum value.

1-3 by the value of Cs0~Cs3 (please see the down figure)

Under other conditions are fixed. Add the capacitors Cs0~Cs3 can fine tune the sensitivity for single key, that lets all key's sensitivity identical. When do not use any capacitor to VSS, the sensitivity is most sensitive. When adding the values of Cs0~Cs3 will reduce sensitivity in the useful range ($0 \leq Cs0 \sim Cs3 \leq 50pF$).

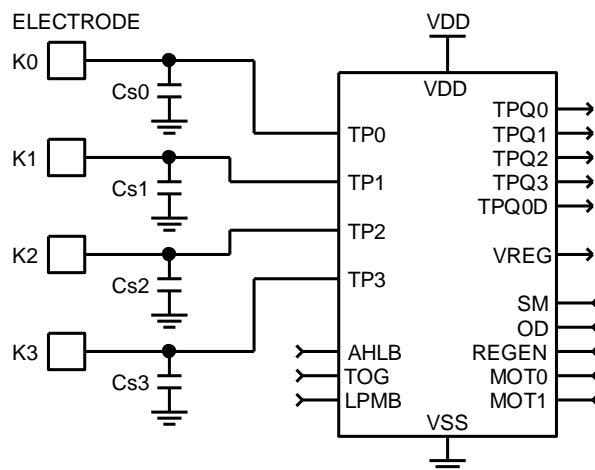

2. Output mode(By TOG, OD, AHLB pad option)

The TTP224N-ASD outputs(TPQ0~TPQ3) has direct mode active high or low by AHLB pad option, has toggle mode by TOG pad option and has open drain(have diode protective circuit) mode by OD pad option. Another TPQ0D is open drain active low output pin has no diode protective circuit.

TOG	OD	AHLB	Pad TPQ0~TP3 option features	Remark
0	1	0	Direct mode, CMOS active high output	Default
0	1	1	Direct mode, CMOS active low output	
0	0	0	Direct mode, Open drain active high output	
0	0	1	Direct mode, Open drain active low output	
1	1	0	Toggle mode, COMS output, Power on state=0	
1	1	1	Toggle mode, COMS output, Power on state=1	
1	0	0	Toggle mode, Power on state high-Z, Active high	
1	0	1	Toggle mode, Power on state high-Z, Active low	

TOG	Pad TPQ0D option features	Remark
0	Direct mode, Open drain active low output, Power on state high-Z	Default
1	Toggle mode, Open drain active low output, Power on state high-Z	

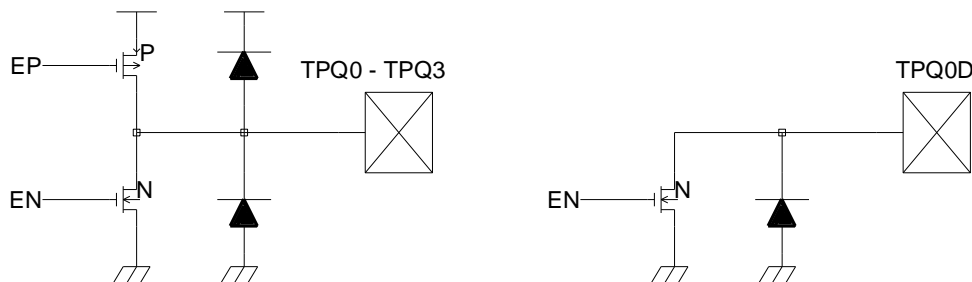

3. Key operating mode(By SM pad option)

TTP224N-ASD has the Single-key and Multi-key functions by SM pad option.

SM	Option features	Remark
1	Multi-key mode	Default
0	Single key mode	

Multi-key mode : the TP0-TP3 can be detected 2 keys or above 2 keys at the same time.

Single-key mode : the TP0-TP3 can be detected 1 key only at the same time, when any key be detected, the other 3 keys can not be detected.

4. Maximum key on duration time (By MOT0, MOT1 pad option)

If some objects cover in the sense pad, and causing the change quantity enough to be detected. To prevent this, the TTP224N-ASD sets a timer to monitor the detection. The timer is the maximum on duration time. When the detection is over the timer, the system will return to the power-on initial state, and the output becomes inactive until the next detection.

MOT1	MOT0	Option features	Remark
0	0	Maximum on time 120sec	
0	1	Maximum on time 64sec	
1	0	Maximum on time 16sec	
1	1	Infinite(Disable maximum on time)	Default

5. Fast and Low power mode selection (By LPMB pad option)

The TTP224N-ASD has Fast mode and Low Power mode to be selected. It depends on the state of LPMB pad. When the LPMB pin is connected to VDD, the TTP224N-ASD runs in Fast mode. When the LPMB pin is opened or connected to VSS, the TTP224N-ASD runs in Low Power mode.

In the Fast mode response time is faster, but the current consumption will be increased. In the Low Power mode it will be saving power, but will be slowing response time for first touch. When it awaked in fast mode, the response time is the same the fast mode. In this mode when detecting key touch, it will switch to Fast mode. Until the key touch is released and will keep a time about 8sec. Then it returns to Low Power mode.

The states and timing of two modes please see below figure.

TTP224N-ASD timing diagram :

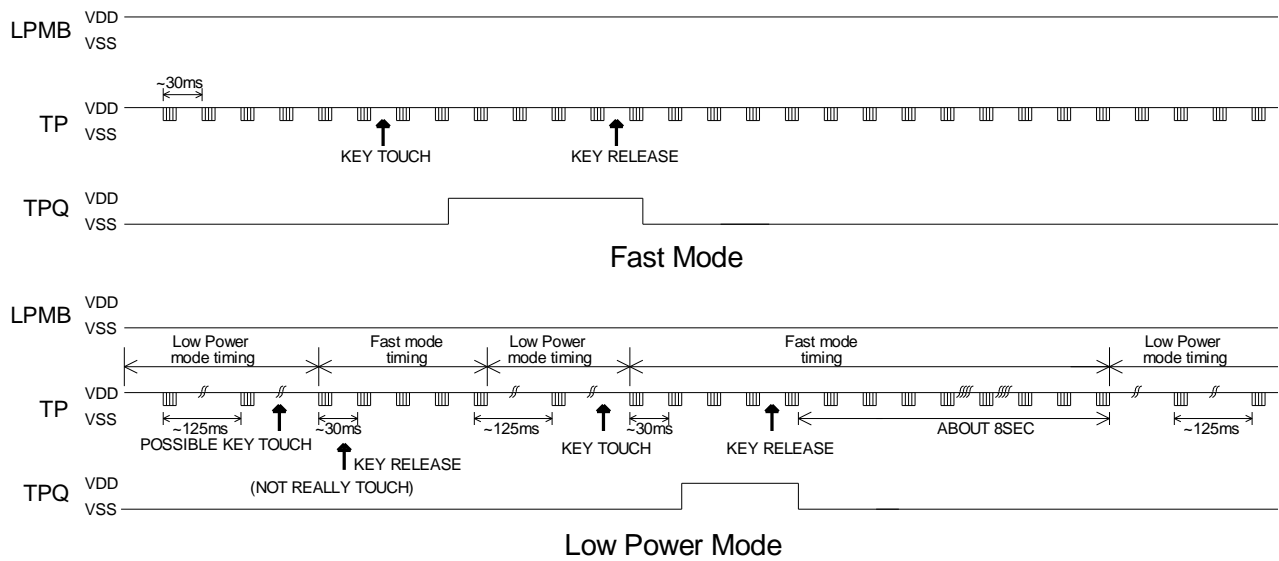

LPMB	Option features	Remark
1	Fast mode	
0	Low Power mode	Default

6. Internal regulator enable/disable

TTP224N-ASD built in regulator in the chip. The regulator can be set enable or disable by the REGEN pin. The REGEN pin is opened or connected to VDD, the regulator is enabled. The REGEN pin is connected to VSS, the regulator is disabled. When the internal regulator is disabled, the VREG pin must be connected to external VDD.

REGEN	Option features	Remark
1	Enable internal regulator	Default
0	Disable internal regulator	

APPLICATION CIRCUIT

TTP224N-ASD APPLICATION (enable internal regulator)

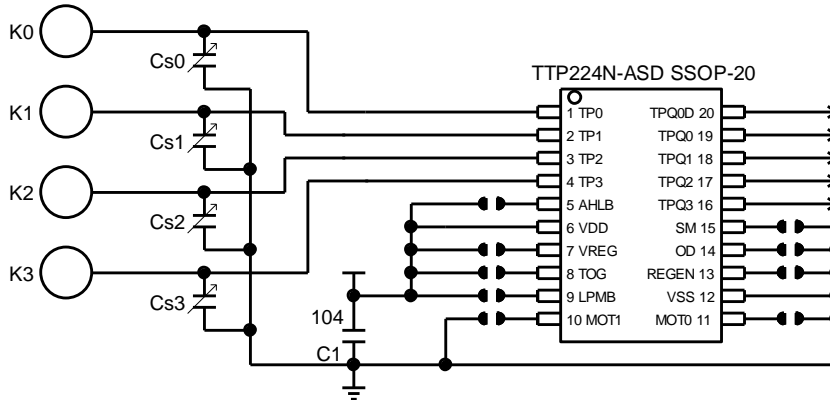

Option table:

Output mode:

TOG	OD	AHLB	Pad TPQ0~TP3 option features
open	open	open	Direct mode, CMOS active high output
open	open	VDD	Direct mode, CMOS active low output
open	VSS	open	Direct mode, Open drain active high output
open	VSS	VDD	Direct mode, Open drain active low output
VDD	open	open	Toggle mode, COMS output, Power on state=0
VDD	open	VDD	Toggle mode, COMS output, Power on state=1
VDD	VSS	open	Toggle mode, Power on state high-Z, Active high
VDD	VSS	VDD	Toggle mode, Power on state high-Z, Active low

TOG	Pad TPQ0D,TPQ2D (has no diode protection) option features
open	Direct mode, Open drain active low output, Power on state high-Z
VDD	Toggle mode, Open drain active low output, Power on state high-Z

Key operation mode:

SM	Option features
open	Multi-key mode
VSS	Single key mode

Maximum key on duration time:

MOT1	MOT0	Option features
VSS	VSS	Maximum on time 120sec
VSS	open	Maximum on time 64sec
open	VSS	Maximum on time 16sec
open	open	Infinite(Disable maximum on time)

Fast and Low power mode:

LPMB	Option features
VDD	Fast mode
open	Low Power mode

PS : 1. On PCB, the length of lines from touch pad to IC pin shorter is better.

And the lines do not parallel and cross with other lines.

- The material of panel covering on the PCB can not include the metal or the electric element. The paints on the surfaces are the same.
- The C1 capacitor must be used between VDD and VSS; and should be routed with very short tracks to the device's VDD and VSS pins .
- The capacitance Cs0~Cs3 can be used to adjust the sensitivity. The value of Cs0~Cs3 use smaller, then the sensitivity will be better. The sensitivity adjustment must according to the practical application on PCB. The range of Cs0~Cs3 value are 0~50pF.
- The sensitivity adjustment capacitors (Cs0~Cs3) must use smaller temperature coefficient and more stable capacitors. Such are X7R, NPO for example. So for touch application, recommend to use NPO capacitor, for reducing that the temperature varies to affect sensitivity.

TTP224N-ASD APPLICATION (disable internal regulator)

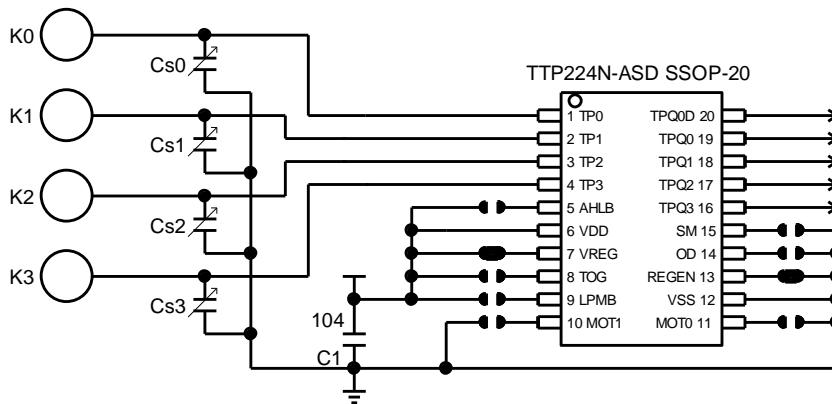

Option table:

Output mode:

TOG	OD	AHLB	Pad TPQ0~TP3 option features
open	open	open	Direct mode, CMOS active high output
open	open	VDD	Direct mode, CMOS active low output
open	VSS	open	Direct mode, Open drain active high output
open	VSS	VDD	Direct mode, Open drain active low output
VDD	open	open	Toggle mode, COMS output, Power on state=0
VDD	open	VDD	Toggle mode, COMS output, Power on state=1
VDD	VSS	open	Toggle mode, Power on state high-Z, Active high
VDD	VSS	VDD	Toggle mode, Power on state high-Z, Active low

TOG	Pad TPQ0D,TPQ2D (has no diode protection) option features
open	Direct mode, Open drain active low output, Power on state high-Z
VDD	Toggle mode, Open drain active low output, Power on state high-Z

Key operation mode:

SM	Option features
open	Multi-key mode
VSS	Single key mode

Maximum key on duration time:

MOT1	MOT0	Option features
VSS	VSS	Maximum on time 120sec
VSS	open	Maximum on time 64sec
open	VSS	Maximum on time 16sec
open	open	Infinite(Disable maximum on time)

Fast and Low power mode:

LPMB	Option features
VDD	Fast mode
open	Low Power mode

PS : 1. On PCB, the length of lines from touch pad to IC pin shorter is better.

And the lines do not parallel and cross with other lines.

- The power supply must be stable. If the supply voltage drift or shift quickly, maybe causing sensitivity anomalies or false detections.
- The material of panel covering on the PCB can not include the metal or the electric element. The paints on the surfaces are the same.
- The C1 capacitor must be used between VDD and VSS; and should be routed with very short tracks to the device's VDD and VSS pins.
- The capacitance Cs0~Cs3 can be used to adjust the sensitivity. The value of Cs0~Cs3 use smaller, then the sensitivity will be better. The sensitivity adjustment must according to the practical application on PCB. The range of Cs0~Cs3 value are 0~50pF.
- The sensitivity adjustment capacitors (Cs0~Cs3) must use smaller temperature coefficient and more stable capacitors. Such are X7R, NPO for example. So for touch application, recommend to use NPO capacitor, for reducing that the temperature varies to affect sensitivity.

Package Type: SSOP-20

Package Outline Dimension

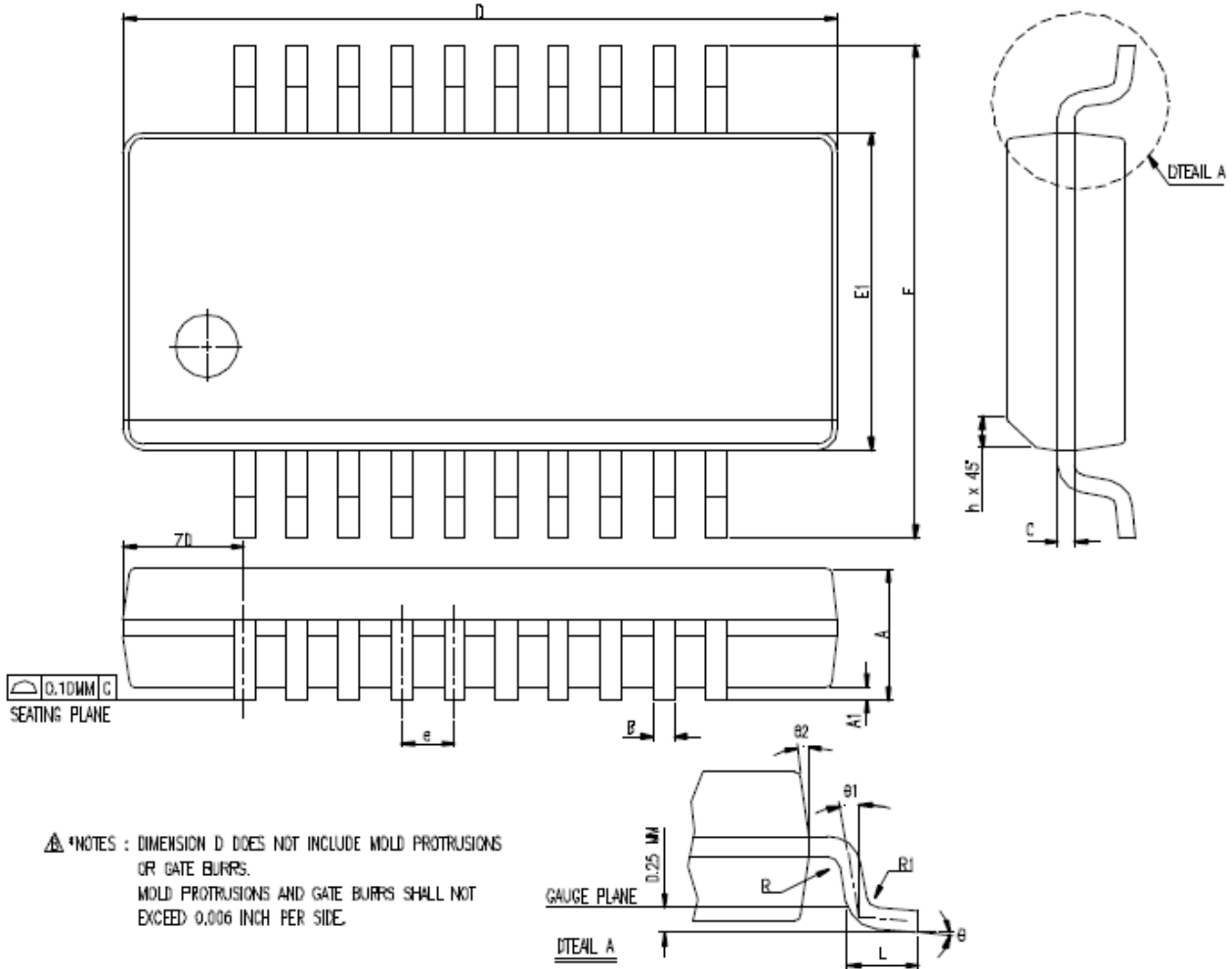

SYMBOL	DIMENSION IN MM			DIMENSION IN INCH		
	MIN.	NOM.	MAX.	MIN.	NOM.	MAX.
A	1.35	1.63	1.75	0.053	0.064	0.069
A1	0.10	0.13	0.25	0.004	0.006	0.010
A2			1.50			0.059
B	0.20		0.30	0.008		0.012
c	0.18		0.25	0.007		0.010
e	0.635 BASIC			0.025 BASIC		
D	8.56	8.86	8.74	0.337	0.341	0.344
E	5.79	5.99	6.20	0.228	0.236	0.244
E1	3.81	3.91	3.99	0.150	0.154	0.157
L	0.41	0.635	1.27	0.016	0.025	0.050
h	0.25		0.50	0.010		0.020
ZD	1.4732REF			0.058 REF.		
R1	0.20		0.33	0.008		0.013
R	0.20			0.008		
θ	0°		8°	0°		8°
θ1	0°			0°		
θ2	5°	10°	15°	5°	10°	15°
JEDEC	MO-137 (AD)					

ORDER INFORMATION

- a. Package form: TTP224N-ASD
- b. Chip form: TCP224N
- c. Wafer base: TDP224-02

REVISE HISTORY

- 1. 2009/06/30
 - Original version : V1.0
- 2. 2009/08/25 → V2.0
 - Add the TTP224N-ASD
- 3. 2010/06/08 → V3.0
 - Add the TTP224L-ASD
- 4. 2014/06/05 → V3.1
 - Remove TTP224-ASD and TTP224L-ASD function