

# ELM99xxxxxC CMOS middle current voltage regulator

## ■ General description

ELM99xxxxxC is CMOS middle current voltage regulator which consists of reference voltage source, error amplifier, low resistance output transistor, short-circuit protection circuit, thermal protection circuit, output voltage setting resistors and chip-enable circuit. ELM99 series is characterized with small input/output voltage difference (with its low resistance output transistor) and high load stability (with its high gain error amplifier). There are 3 types of CE selection of ELM99 series: non-chip enable function, “L” active and “H” active. The standard output voltages are 3.3V, 5.0V; these output voltages are fixed internally with high accuracy. ELM99 series can also be made as semi-custom IC within the range of 1.5V to 15.0V by 0.1V step.

## ■ Features

- Output voltage range : 1.5V to 15.0V (by 0.1V)
- Max. output current : 300mA (Current is limited internally)
- Stand-by current consumption : Max. 0.1μA (ELM99033xxC)
- Input stability : Typ. 0.1%/V (I<sub>out</sub>=40mA)
- Load stability : Typ. 5mV (1mA ≤ I<sub>out</sub> ≤ 100mA)
- Accuracy of output voltage : ±2.0%
- Protection circuit : Thermal protection, Short protection
- Package : SOT-89, SOT-89-5, SOT-23, SOT-25

## ■ Application

- Battery operated devices
- Digital cameras
- Video recorders
- Reference voltage source

## ■ Maximum absolute ratings

Parameter	Symbol	Limit	Unit
Input voltage	V <sub>in</sub>	20	V
CE/CE Input voltage	V <sub>ce</sub>	V <sub>ss</sub> -0.3 to V <sub>in</sub> +0.3	V
Output voltage	V <sub>out</sub>	V <sub>ss</sub> -0.3 to V <sub>in</sub> +0.3	V
Output current	I <sub>out</sub>	500	mA
Power dissipation	P <sub>d</sub>	500 (SOT-89, SOT-89-5)	mW
		300 (SOT-25)	
		250 (SOT-23)	
Operating temperature	T <sub>op</sub>	-40 to +85	°C
Storage temperature	T <sub>stg</sub>	-55 to +125	°C

\* Output current must not exceed power dissipation specified in maximum absolute ratings.

## ■ Selection guide

ELM99xxxxxC-x

Symbol		
a, b, c	Output voltage	e.g. : 033: V <sub>out</sub> =3.3V, 050: V <sub>out</sub> =5.0V
d	CE selection	1: No CE 2: $\overline{CE}$ ="L" active 3: CE="H" active
e	Package	A: SOT-89, SOT-89-5 B: SOT-23, SOT-25
f	Product version	C
g	Taping direction	S, N: Refer to PKG file

ELM99 x x x x x C - x  
 ↑ ↑ ↑ ↑ ↑ ↑ ↑  
 a b c d e f g

# ELM99xxxxC CMOS Middle current voltage regulator

## ■ Pin configuration

SOT-89(TOP VIEW)

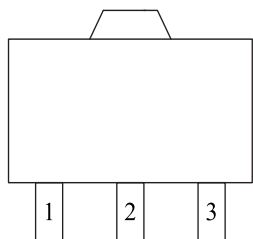

ELM99xxx1AC

Pin No.	Pin name
1	VSS
2	VIN
3	VOUT

SOT-23(TOP VIEW)

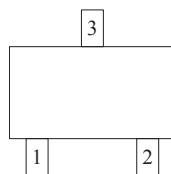

ELM99xxx1BC

Pin No.	Pin name
1	VIN
2	VOUT
3	VSS

SOT-89-5(TOP VIEW)

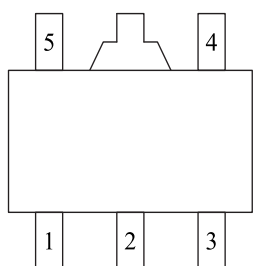

ELM99xxx2AC  
ELM99xxx3AC

Pin No.	Pin name
1	VSS
2	VIN
3	VOUT
4	NC
5	$\overline{CE}/CE$

SOT-25(TOP VIEW)

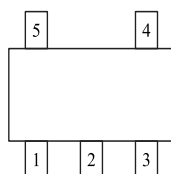

ELM99xxx2BC  
ELM99xxx3BC

Pin No.	Pin name
1	VIN
2	VSS
3	NC
4	$\overline{CE}/CE$
5	VOUT

## ■ Standard circuit

ELM99xxx1xC

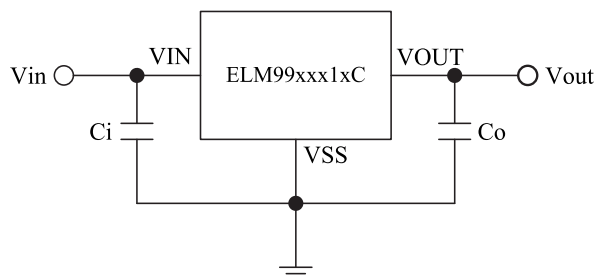

ELM99xxx2xC:  $\overline{CE}$ , ELM99xxx3xC: CE

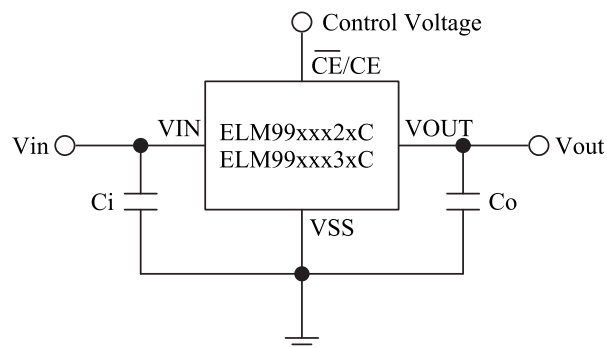

\* Please connect 1.0 $\mu$ F at minimum for Ci and Co. Ceramic capacitors with 2.2 $\mu$ F or greater are recommended for stability operation.

## ■ Block diagram

ELM99xxx1xC

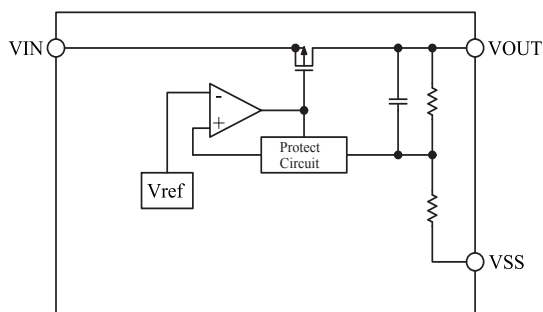

ELM99xxx2xC:  $\overline{CE}$ , ELM99xxx3xC: CE

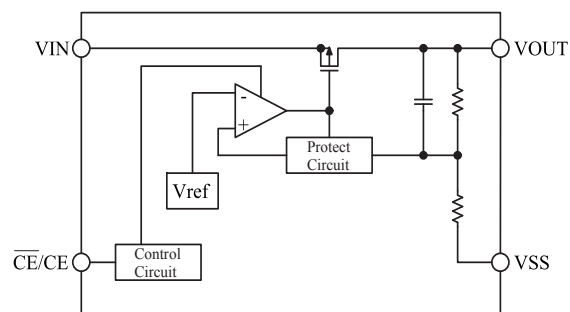

## ELM99xxxxxC CMOS Middle current voltage regulator

### ■Electrical characteristics (ELM99xxx1xC)

Vout=3.3V(ELM990331xC), No CE pin

Top=25°C

Parameter	Symbol	Condition	Min.	Typ.	Max.	Unit
Output voltage	Vout	Vin=4.3V, Iout=40mA	3.234	3.300	3.366	V
Output current	Iout	Vin=4.3V	170	300		mA
Input stability	$\Delta V_{out}/\Delta V_{in}$	Iout=40mA, 4.3V $\leq$ Vin $\leq$ 18.0V		0.02	0.30	%/V
Load stability	$\Delta V_{out}/\Delta I_{out}$	1mA $\leq$ Iout $\leq$ 100mA, Vin=4.3V		5	15	mV
Input/output voltage differential	Vdif	Iout=40mA		110	265	mV
Current consumption	I <sub>ss</sub>	Vin=4.3V, No-load		25	45	$\mu$ A
Input voltage	Vin		2.2		18.0	V
Output voltage temperature coefficient	$\Delta V_{out}/\Delta T_{op}$	Vin=4.3V, Iout=40mA, Top=-40°C~+85°C		$\pm$ 100		ppm/°C
Short circuit current	I <sub>lim</sub>	Vin=4.3V, Vout=0V		40		mA
Ripple rejection ratio	RR	Vin=4.3V, f=1kHz, Iout=40mA		60		dB
Thermal shutdown temperature	Tsd			160		°C
Output noise	Vno	Vin=4.3V, BW=10Hz~100kHz		30		$\mu$ V <sub>rms</sub>

Vout=5.0V(ELM990501xC), No CE pin

Top=25°C

Parameter	Symbol	Condition	Min.	Typ.	Max.	Unit
Output voltage	Vout	Vin=6.0V, Iout=40mA	4.900	5.000	5.100	V
Output current	Iout	Vin=6.0V	200	330		mA
Input stability	$\Delta V_{out}/\Delta V_{in}$	Iout=40mA, 6.0V $\leq$ Vin $\leq$ 18.0V		0.02	0.30	%/V
Load stability	$\Delta V_{out}/\Delta I_{out}$	1mA $\leq$ Iout $\leq$ 100mA, Vin=6.0V		5	15	mV
Input/output voltage differential	Vdif	Iout=40mA		85	220	mV
Current consumption	I <sub>ss</sub>	Vin=6.0V, No-load		30	55	$\mu$ A
Input voltage	Vin		2.2		18.0	V
Output voltage temperature coefficient	$\Delta V_{out}/\Delta T_{op}$	Vin=6.0V, Iout=40mA, Top=-40°C~+85°C		$\pm$ 100		ppm/°C
Short circuit current	I <sub>lim</sub>	Vin=6.0V, Vout=0V		40		mA
Ripple rejection ratio	RR	Vin=6.0V, f=1kHz, Iout=40mA		60		dB
Thermal shutdown temperature	Tsd			160		°C
Output noise	Vno	Vin=6.0V, BW=10Hz~100kHz		30		$\mu$ V <sub>rms</sub>

## ELM99xxxxxC CMOS Middle current voltage regulator

### ■Electrical characteristics (ELM99xxx2xC)

Vout=3.3V(ELM990332xC),  $\overline{CE}$ =”L”active

Top=25°C

Parameter	Symbol	Condition	Min.	Typ.	Max.	Unit
Output voltage	Vout	Vin=4.3V, Iout=40mA	3.234	3.300	3.366	V
Output current	Iout	Vin=4.3V	170	300		mA
Input stability	$\Delta V_{out}/\Delta V_{in}$	Iout=40mA, 4.3V≤Vin≤18.0V		0.02	0.30	%/V
Load stability	$\Delta V_{out}/\Delta I_{out}$	1mA≤Iout≤100mA, Vin=4.3V		5	15	mV
Input/output voltage differential	Vdif	Iout=40mA		110	265	mV
Current consumption	I <sub>ss</sub>	Vin=4.3V, Vce=V <sub>ss</sub> , No-load		25	45	μA
Stand-by current consumption	I <sub>standby</sub>	Vin=Vce=4.3V		0.0	0.1	μA
Input voltage	Vin		2.2		18.0	V
$\overline{CE}$ Input voltage High	Vceh	Vin=18.0V	1.80		Vin	V
$\overline{CE}$ Input voltage Low	Vcel	Vin=2.2V	0.00		0.25	
$\overline{CE}$ Input current High	Iceh	Vin=Vce=18V	-0.2		0.2	μA
$\overline{CE}$ Input current Low	Icel	Vin=18V, Vce=V <sub>ss</sub>	-0.2		0.2	
Output voltage temperature coefficient	$\Delta V_{out}/\Delta T_{op}$	Vin=4.3V, Iout=40mA, Top=-40°C~+85°C		±100		ppm/°C
Short circuit current	I <sub>lim</sub>	Vin=4.3V, Vout=0V		40		mA
Ripple rejection ratio	RR	Vin=4.3V, f=1kHz, Iout=40mA		60		dB
Thermal shutdown temperature	T <sub>sd</sub>			160		°C
Output noise	V <sub>no</sub>	Vin=4.3V, BW=10Hz~100kHz		30		μV <sub>rms</sub>

Vout=5.0V(ELM990502xC),  $\overline{CE}$ =”L”active

Top=25°C

Parameter	Symbol	Condition	Min.	Typ.	Max.	Unit
Output voltage	Vout	Vin=6.0V, Iout=40mA	4.900	5.000	5.100	V
Output current	Iout	Vin=6.0V	200	330		mA
Input stability	$\Delta V_{out}/\Delta V_{in}$	Iout=40mA, 6.0V≤Vin≤18.0V		0.02	0.30	%/V
Load stability	$\Delta V_{out}/\Delta I_{out}$	1mA≤Iout≤100mA, Vin=6.0V		5	15	mV
Input/output voltage differential	Vdif	Iout=40mA		85	220	mV
Current consumption	I <sub>ss</sub>	Vin=6.0V, Vce=V <sub>ss</sub> , No-load		30	55	μA
Stand-by current consumption	I <sub>standby</sub>	Vin=6.0V, Vce=V <sub>ss</sub>		0.0	0.1	μA
Input voltage	Vin		2.2		18.0	V
$\overline{CE}$ Input voltage High	Vceh	Vin=18.0V	1.80		Vin	V
$\overline{CE}$ Input voltage Low	Vcel	Vin=2.2V	0.00		0.25	
$\overline{CE}$ Input current High	Iceh	Vin=Vce=18V	-0.2		0.2	μA
$\overline{CE}$ Input current Low	Icel	Vin=18, Vce=V <sub>ss</sub>	-0.2		0.2	
Output voltage temperature coefficient	$\Delta V_{out}/\Delta T_{op}$	Vin=6.0V, Iout=40mA, Top=-40°C~+85°C		±100		ppm/°C
Short circuit current	I <sub>lim</sub>	Vin=6.0V, Vout=0V		40		mA
Ripple rejection ratio	RR	Vin=6.0V, f=1kHz, Iout=40mA		60		dB
Thermal shutdown temperature	T <sub>sd</sub>			160		°C
Output noise	V <sub>no</sub>	Vin=6.0V, BW=10Hz~100kHz		30		μV <sub>rms</sub>

## ELM99xxxxC CMOS Middle current voltage regulator

### ■Electrical characteristics (ELM99xxx3xC)

Vout=3.3V(ELM990333xC), CE="H"active

Top=25°C

Parameter	Symbol	Condition	Min.	Typ.	Max.	Unit
Output voltage	Vout	Vin=4.3V, Iout=40mA	3.234	3.300	3.366	V
Output current	Iout	Vin=4.3V	170	300		mA
Input stability	$\Delta V_{out}/\Delta V_{in}$	Iout=40mA, 4.3V≤Vin≤18.0V		0.02	0.30	%/V
Load stability	$\Delta V_{out}/\Delta I_{out}$	1mA≤Iout≤100mA, Vin=4.3V		5	15	mV
Input/output voltage differential	Vdif	Iout=40mA		110	265	mV
Current consumption	I <sub>ss</sub>	Vin=Vce=4.3V, No-load		25	45	μA
Stand-by current consumption	I <sub>standby</sub>	Vin=Vce=4.3V		0.0	0.1	μA
Input voltage	Vin		2.2		18.0	V
CE Input voltage High	Vceh	Vin=18.0V	1.80		Vin	V
CE Input voltage Low	Vcel	Vin=2.2V	0.00		0.25	
CE Input current High	Iceh	Vin=Vce=18.0V	-0.2		0.2	μA
CE Input current Low	Icel	Vin=18V, Vce=Vss	-0.2		0.2	
Output voltage temperature coefficient	$\Delta V_{out}/\Delta T_{op}$	Vin=4.3V, Iout=40mA, Top=-40°C~+85°C		±100		ppm/°C
Short circuit current	I <sub>lim</sub>	Vin=4.3V, Vout=0V		40		mA
Ripple rejection ratio	RR	Vin=4.3V, f=1kHz, Iout=40mA		60		dB
Thermal shutdown temperature	Tsd			160		°C
Output noise	Vno	Vin=4.3V, BW=10Hz~100kHz		30		μVrms

Vout=5.0V(ELM990503xC), CE="H"active

Top=25°C

Parameter	Symbol	Condition	Min.	Typ.	Max.	Unit
Output voltage	Vout	Vin=6.0V, Iout=40mA	4.900	5.000	5.100	V
Output current	Iout	Vin=6.0V	200	330		mA
Input stability	$\Delta V_{out}/\Delta V_{in}$	Iout=40mA, 6.0V≤Vin≤18.0V		0.02	0.30	%/V
Load stability	$\Delta V_{out}/\Delta I_{out}$	1mA≤Iout≤100mA, Vin=6.0V		5	15	mV
Input/output voltage differential	Vdif	Iout=40mA		85	220	mV
Current consumption	I <sub>ss</sub>	Vin=Vce=6.0V, No-load		30	55	μA
Stand-by current consumption	I <sub>standby</sub>	Vin=6.0V, Vce=Vss		0.0	0.1	μA
Input voltage	Vin		2.2		18.0	V
CE Input voltage High	Vceh	Vin=18.0V	1.80		Vin	V
CE Input voltage Low	Vcel	Vin=2.2V	0.00		0.25	
CE Input current High	Iceh	Vin=Vce=18.0V	-0.1		0.1	μA
CE Input current Low	Icel	Vin=18.0V, Vce=Vss	-0.1		0.1	
Output voltage temperature coefficient	$\Delta V_{out}/\Delta T_{op}$	Vin=6.0V, Iout=40mA, Top=-40°C~+85°C		±100		ppm/°C
Short circuit current	I <sub>lim</sub>	Vin=6.0V, Vout=0V		40		mA
Ripple rejection ratio	RR	Vin=6.0V, f=1kHz, Iout=40mA		60		dB
Thermal shutdown temperature	Tsd			160		°C
Output noise	Vno	Vin=6.0V, BW=10Hz~100kHz		30		μVrms

# ELM99xxxxxC CMOS Middle current voltage regulator

## ■ Marking

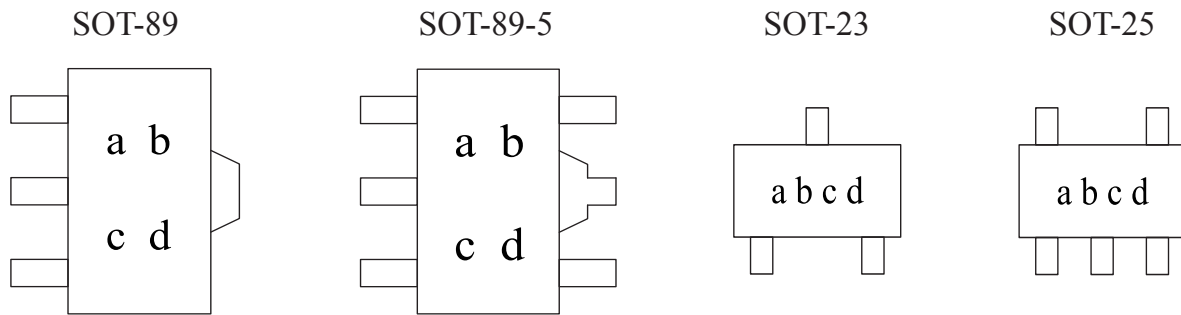

a, b : Represents Output voltage range , Package type and CE type.

Symbol	Output voltage range (V)	Package	CE Type
60	1.5~4.0	SOT-89	No CE
61	4.1~7.0	SOT-89	No CE
62	7.1~10.0	SOT-89	No CE
63	10.1~13.0	SOT-89	No CE
64	13.1~15.0	SOT-89	No CE
65	1.5~4.0	SOT-89-5	CE=Lo
66	4.1~7.0	SOT-89-5	CE=Lo
67	7.1~10.0	SOT-89-5	CE=Lo
68	10.1~13.0	SOT-89-5	CE=Lo
69	13.1~15.0	SOT-89-5	CE=Lo
6A	1.5~4.0	SOT-89-5	CE=High
6B	4.1~7.0	SOT-89-5	CE=High
6C	7.1~10.0	SOT-89-5	CE=High
6D	10.1~13.0	SOT-89-5	CE=High
6E	13.1~15.0	SOT-89-5	CE=High
6F	1.5~4.0	SOT-23	No CE
6G	4.1~7.0	SOT-23	No CE
6H	7.1~10.0	SOT-23	No CE
6J	10.1~13.0	SOT-23	No CE
6K	13.1~15.0	SOT-23	No CE
6L	1.5~4.0	SOT-25	CE=Lo
6M	4.1~7.0	SOT-25	CE=Lo
6N	7.1~10.0	SOT-25	CE=Lo
6P	10.1~13.0	SOT-25	CE=Lo
6Q	13.1~15.0	SOT-25	CE=Lo
6R	1.5~4.0	SOT-25	CE=High
6S	4.1~7.0	SOT-25	CE=High
6T	7.1~10.0	SOT-25	CE=High
6U	10.1~13.0	SOT-25	CE=High
6V	13.1~15.0	SOT-25	CE=High

# ELM99xxxxxC CMOS Middle current voltage regulator

c : Represents Output voltage.

Symbol	Output voltage(V)				
1		4.1	7.1	10.1	13.1
2		4.2	7.2	10.2	13.2
3		4.3	7.3	10.3	13.3
4		4.4	7.4	10.4	13.4
5	1.5	4.5	7.5	10.5	13.5
6	1.6	4.6	7.6	10.6	13.6
7	1.7	4.7	7.7	10.7	13.7
8	1.8	4.8	7.8	10.8	13.8
9	1.9	4.9	7.9	10.9	13.9
0	2.0	5.0	8.0	11.0	14.0
A	2.1	5.1	8.1	11.1	14.1
B	2.2	5.2	8.2	11.2	14.2
C	2.3	5.3	8.3	11.3	14.3
D	2.4	5.4	8.4	11.4	14.4
E	2.5	5.5	8.5	11.5	14.5
F	2.6	5.6	8.6	11.6	14.6
G	2.7	5.7	8.7	11.7	14.7
H	2.8	5.8	8.8	11.8	14.8
J	2.9	5.9	8.9	11.9	14.9
K	3.0	6.0	9.0	12.0	15.0
L	3.1	6.1	9.1	12.1	
M	3.2	6.2	9.2	12.2	
N	3.3	6.3	9.3	12.3	
P	3.4	6.4	9.4	12.4	
Q	3.5	6.5	9.5	12.5	
R	3.6	6.5	9.6	12.6	
S	3.7	6.7	9.7	12.7	
T	3.8	6.8	9.8	12.8	
U	3.9	6.9	9.9	12.9	
V	4.0	7.0	10.0	13.0	

d : Represents the assembly lot number  
 1~0, A~Z repeated (I,O,X excepted)

# ELM99xxxxC CMOS Middle current voltage regulator

## ■ Typical characteristics

- ELM99xxx2xC, ELM99xxx3xC

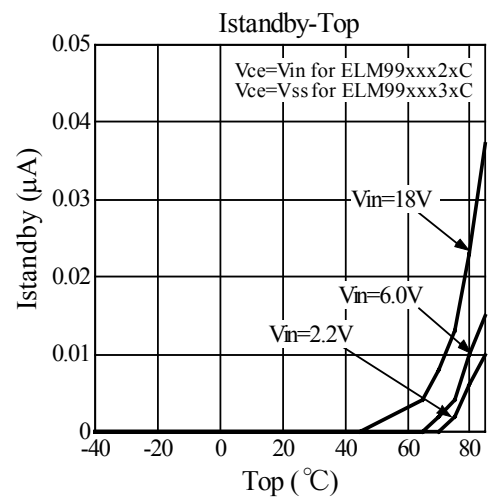
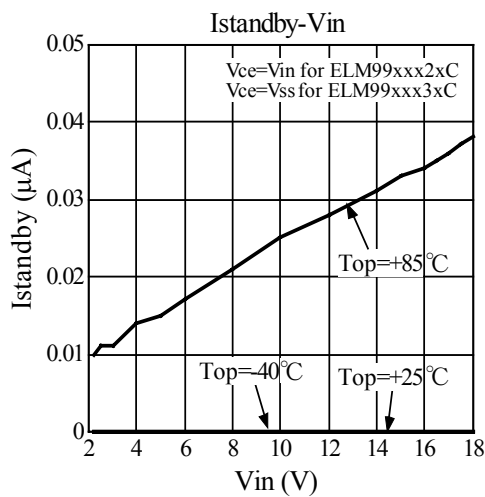
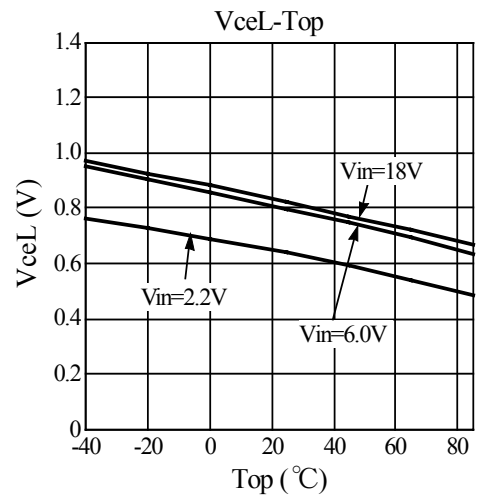
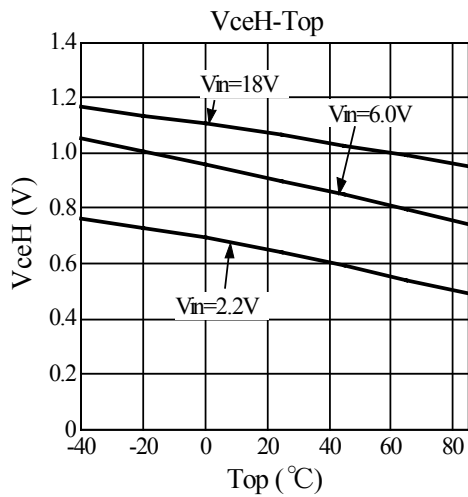
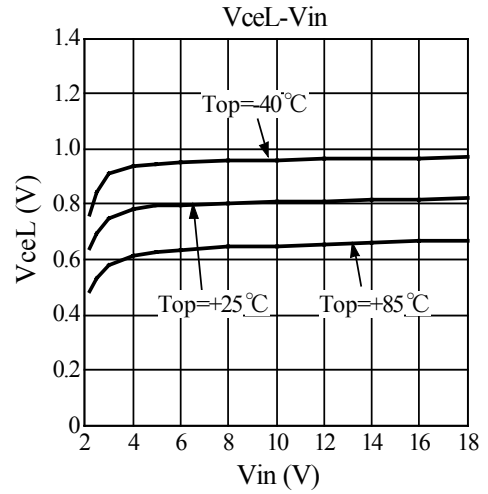
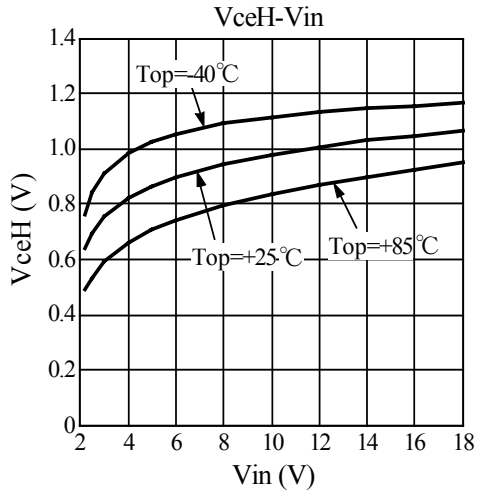



# ELM99xxxxC CMOS Middle current voltage regulator

- $V_{out}=3.3V$ (ELM99033xxC)

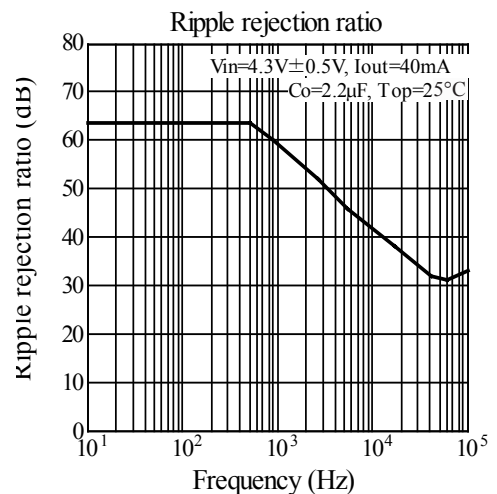
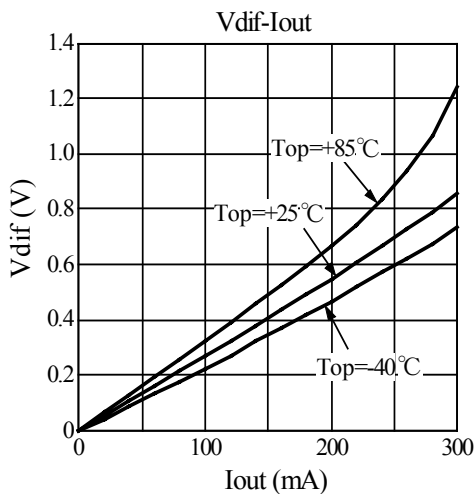
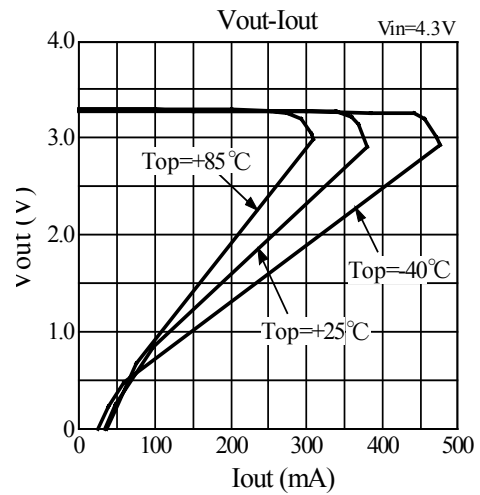
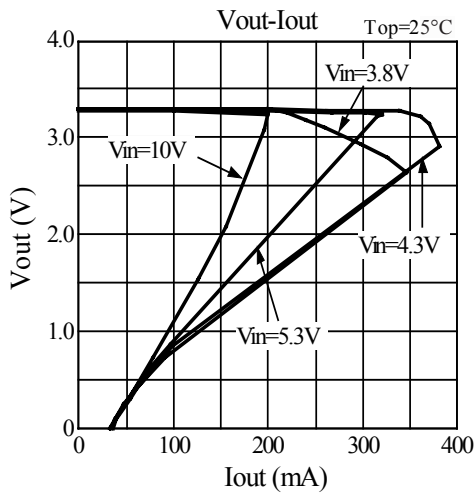
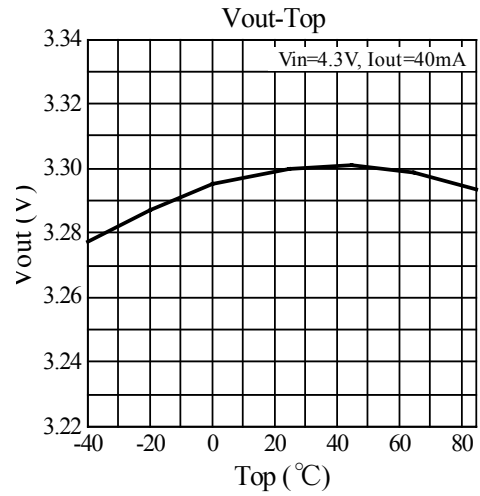
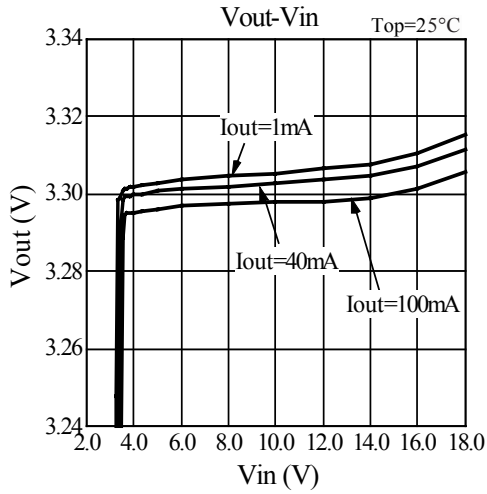

# ELM99xxxxxC CMOS Middle current voltage regulator

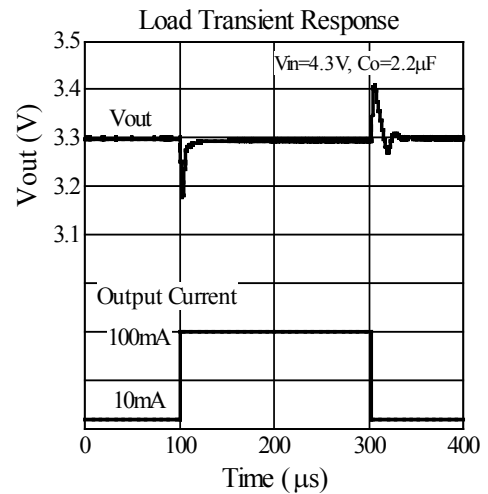
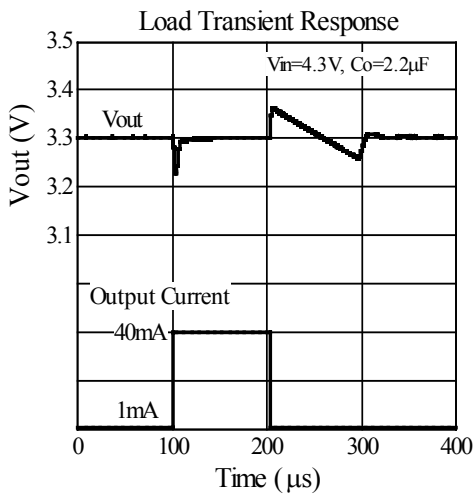
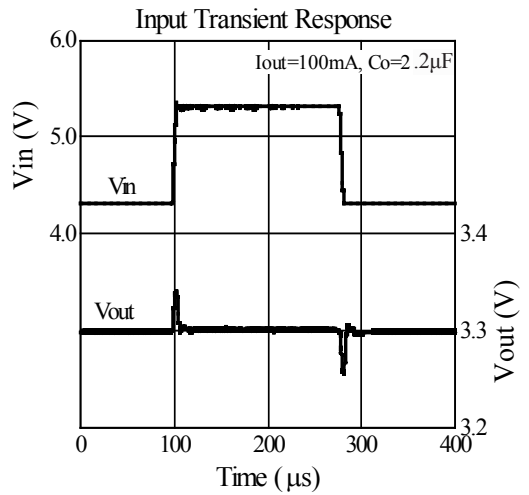
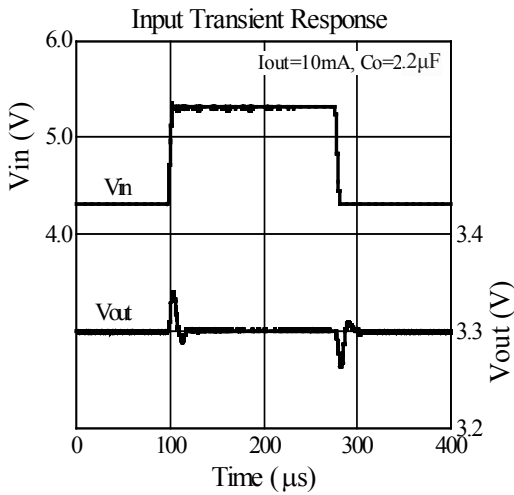
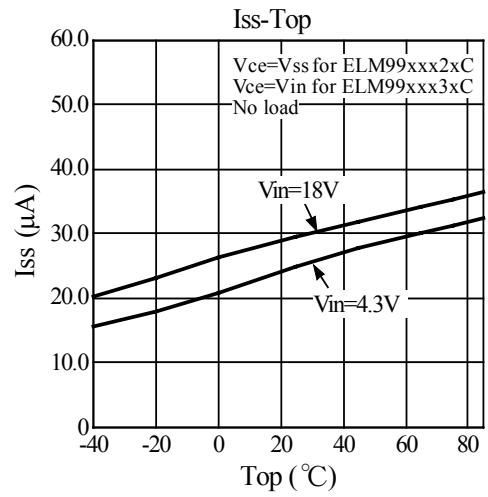
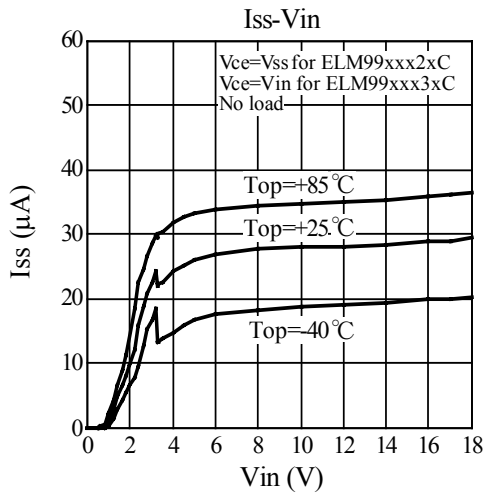

# ELM99xxxxxC CMOS Middle current voltage regulator

- $V_{out}=5.0V$ (ELM99050xxC)

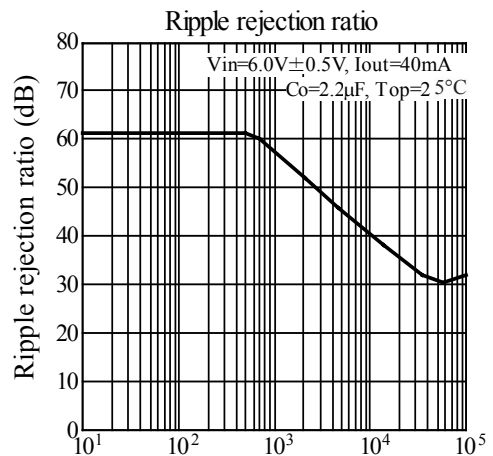
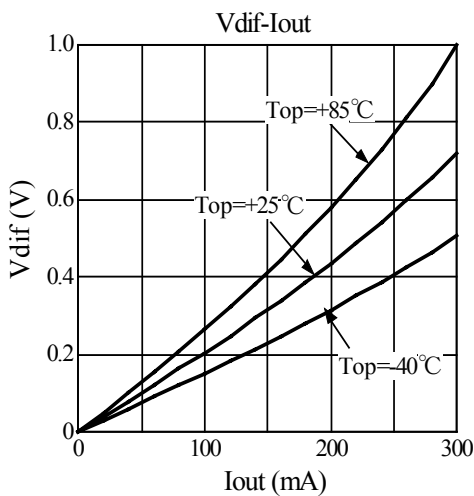
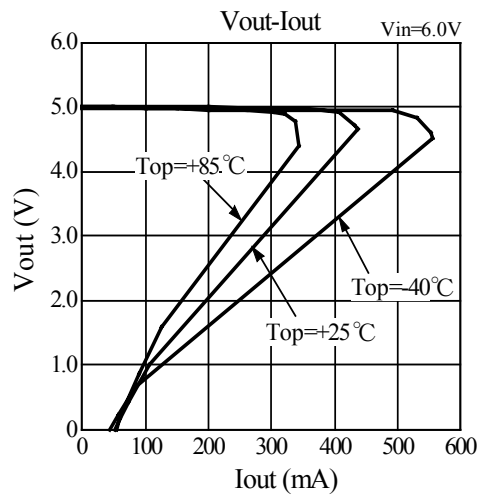
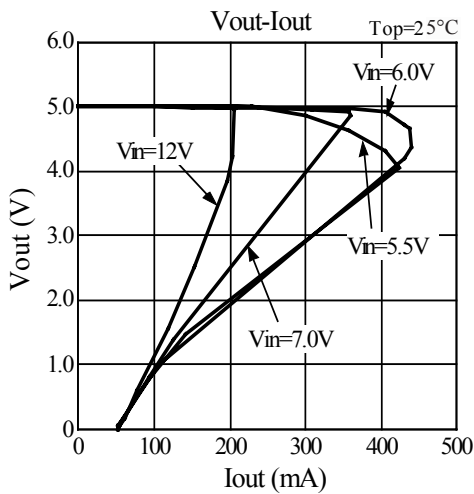
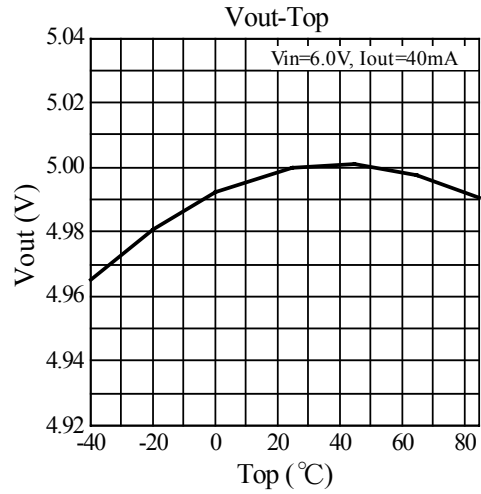
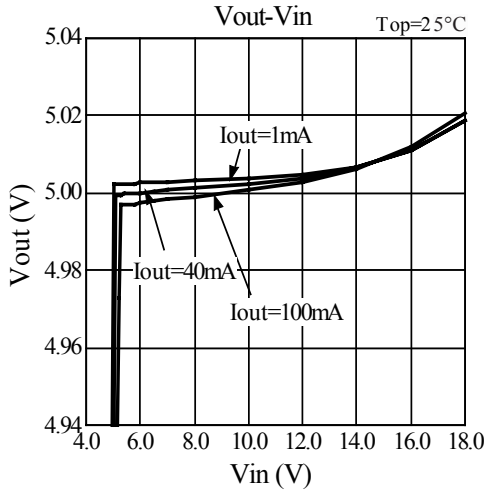

# ELM99xxxxC CMOS Middle current voltage regulator

