

**SPECIFICATIONS FOR  
LCD MODULE**

**Module No. JHB320240B**

E-mail: [sales@jhlcd.com](mailto:sales@jhlcd.com)

Website: [www.jhlcd.com](http://www.jhlcd.com)

## TABLE OF CONTENTS

LCM NUMBER SYSTEM.....	2
1. GENERAL DESCRIPTION.....	3
2. FEATURES .....	3
3. MECHANICAL SPECIFICATION .....	3
4. MECHANICAL DIMENSION .....	4
5. MAXIMUM RATINGS.....	5
6. ELECTRICAL CHARACTERISTICS .....	5
7. MODULE FUNCTION DESCRIPTION .....	6
8. ELECTRO-OPTICAL CHARACTERISTICS .....	39
9. RELIABILITY.....	43
10. PRECAUTIONS FOR USING LCD MODULES .....	44
11. USING LCD MODULES .....	46
12. REVISION HISTORY .....	48
SAMPLE APPROVED REPORT.....	49

## LCM Number System

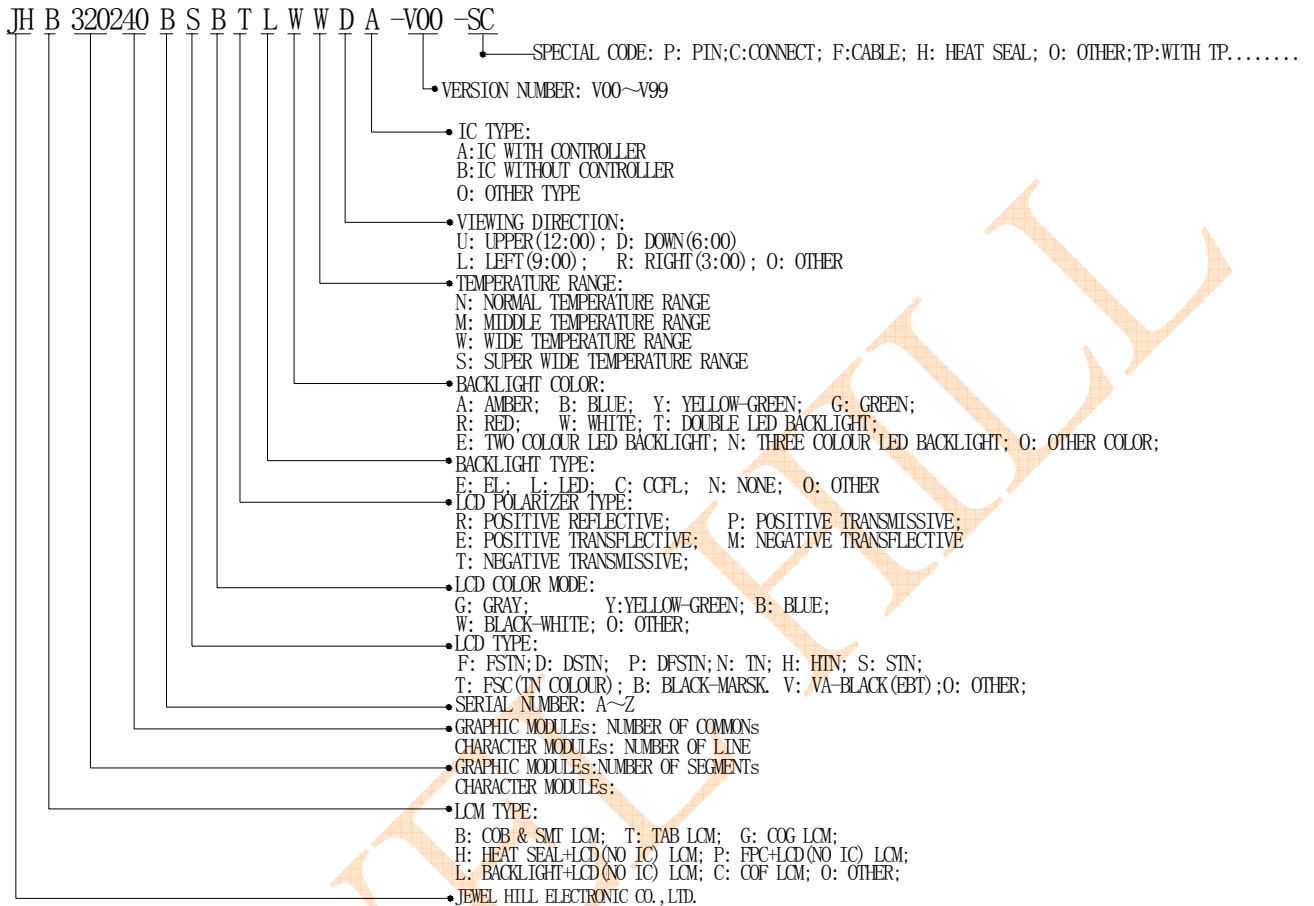

## 1. GENERAL DESCRIPTION

The JHB320240B is a 320 x 240 Dots Graphics LCD module. It has a STN panel composed of 320 segments and 240 commons. The LCM can be easily accessed by micro-controller via parallel interface.

## 2. FEATURES

Display Mode	Transmissive and Negative STN(BLUE) module
Display Format	Graphic 320 x 240 dots
Input Data	Parallel data input from MPU
Multiplexing Ratio	1/240 Duty
Bias	1/16 Bias
Viewing Direction	6 O'clock
Backlight	LED(WHITE)

## 3. MECHANICAL SPECIFICATION

Item	Specifications	Unit
Dimensional outline	160.0 x 109.0 x 11.0(max)	mm
Resolution	320segs x 240coms	dots
View area	122.0(W) x 92.0(H)	mm
Active area	115.17(W) x 86.37(H)	mm
Dots pitch	0.36 (W)×0.36(H)	mm
Dots size	0.33(W)×0.33(H)	mm

## 4. MECHANICAL DIMENSION

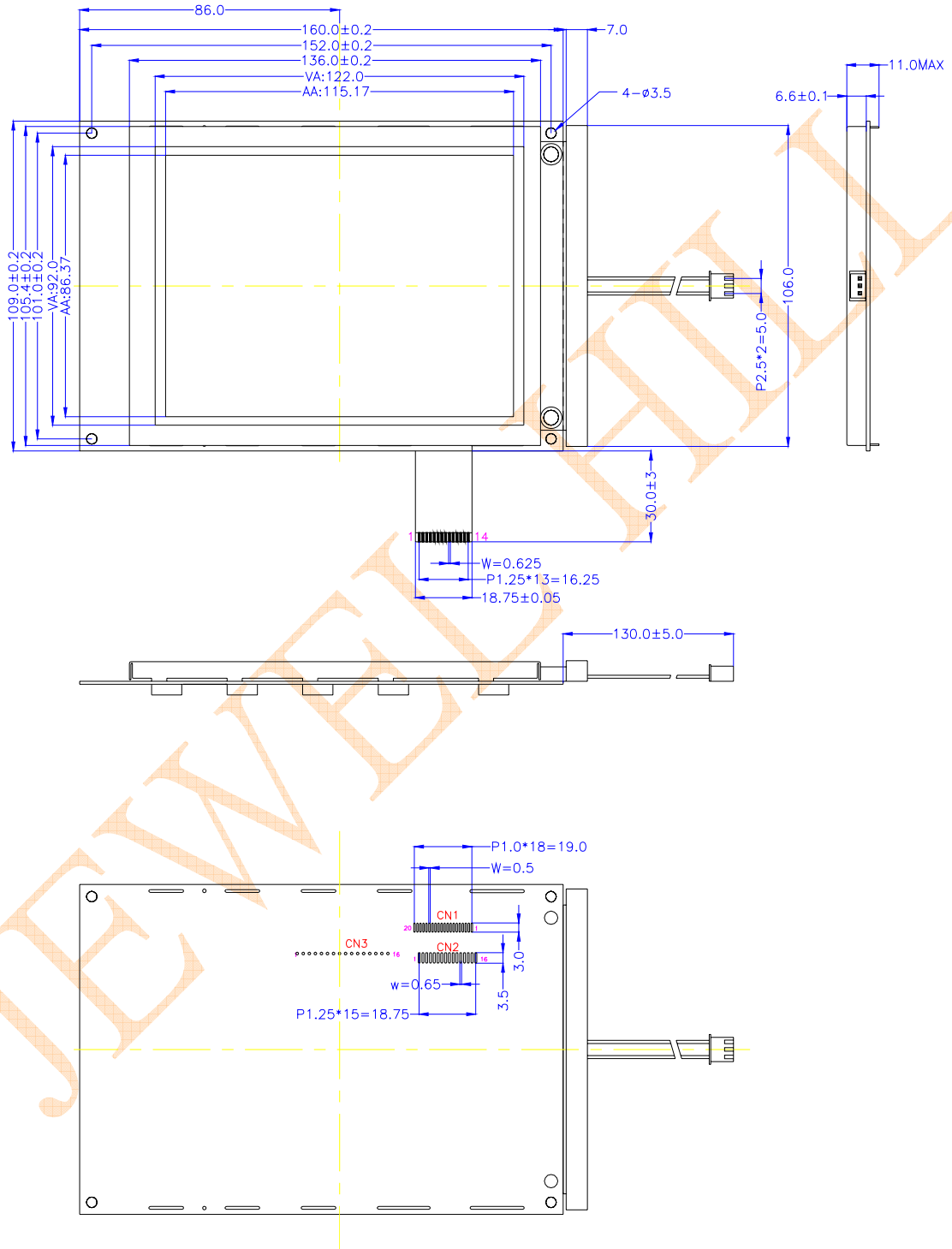

## 5. MAXIMUM RATINGS

Item	Symbol	Min	Max	Unit	Note
Supply voltage	$V_{DD} - V_{SS}$	-0.3	7.0	V	
	$V_{LCD}$	-0.3	30.0	V	
Input Voltage	$V_{IN}$	-0.3	$V_{DD}+0.3$	V	
Operating temperature	$T_{OPR}$	-20	+70	°C	
Storage temperature	$T_{STR}$	-30	+80	°C	
Humidity	---	---	90	%RH	

## 6. ELECTRICAL CHARACTERISTICS

Item		Symbol	Condition	Min.	Typ.	Max.	Unit
Supply Voltage	Logic	$V_{DD}$	---	---	5.0	5.5	V
Input Voltage	H level	$V_{IH}$	---	$0.8V_{DD}$	---	$V_{DD}$	V
	L level	$V_{IL}$		$V_{SS}$	---	$0.2V_{DD}$	
Current Consumption (LCD DRIVER)		$I_{DD}$	$V_{DD}=5.0V;$ $V_{LCD}=25.0V,$ $T_{amb}=25^{\circ}C;$	---	90	120	mA
LCD Driving Voltage		$V_{LCD}$	Bias=1/16 $V_{LCD}=V_{DD}-V_0$	24.5	25	25.5	V
Power Supply for LED		$V_f$	$I_f=150mA$	2.9	3.1	3.3	V
Current Consumption (With LED BackLight)		$I_{LED}$	$V_{DD}=5.0V;$ $V_{LED}=3.1V, T_{amb}=25^{\circ}C;$	---	150	200	mA

## 7. MODULE FUNCTION DESCRIPTION

### 7.1. PIN DESCRIPTION

#### 7.1.1. INTERFACE WITH CONTROLLER

Pin No.	Symbol	Description
1	VSS	Power supply for Ground(0V)
2	VDD	Power supply for positive(+5V)
3	VO	Contrast adjustment voltage
4	/RD	Read signal
5	/WR	Write signal
6	A0	Data type select
7	DB0	8-bit bi-directional data bus
8	DB1	
9	DB2	
10	DB3	
11	DB4	
12	DB5	
13	DB6	
14	DB7	
15	/CS	Chip signal
16	/RST	Reset signal
17	VLCD	Power supply voltage for LCD
18	FG	Frame GND
19	LEDA	Power Supply for LED Positive
20	LEDK	Power Supply for LED Negative

**7.1.2. INTERFACE WITHOUT CONTROLLER**

Pin No.	Symbol	Description
1	DB0	Data Bit 0
2	DB1	Data Bit1
3	DB2	Data Bit2
4	DB3	Data Bit3
5	/DISPOFF	Display OFF Signal, Active Low
6	FLM	Frame Start Signal
7	NC	No Connect
8	CL1	Common Driver Data Shift Signal
9	CL2	Clock Pulse for Segment Shift Register
10	VDD	Power Supply for Positive (+5V)
11	VSS	Power Supply for Ground
12	VEE	Negative Voltage for LCD Power Supply
13	VO	Contrast Adjustment Voltage
14	FGND	Frame Ground



## 7.2 TIMING CHARACTERISTICS

### 1. SYSTEM BUS READ/WRITE CHARACTERISTIC

#### System bus READ/WRITE timing I (8080)

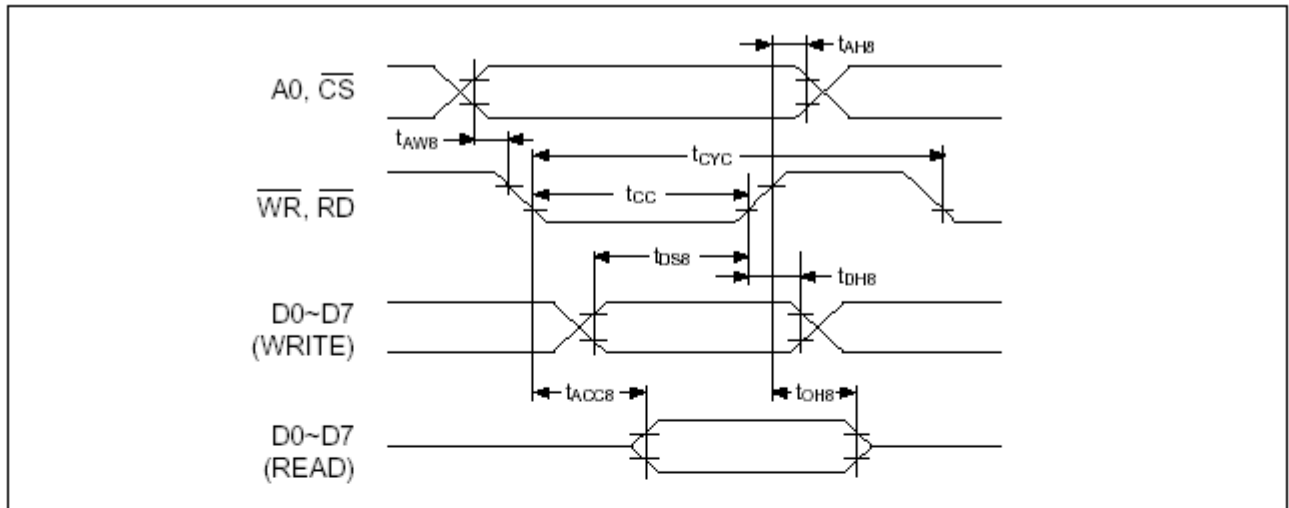

System bus READ/WRITE timing I (8080)

Ta = -20 to 75°C

Signal	Symbol	Parameter	Rating		Unit	Condition
			min	max		
A0, $\overline{CS}$	tAH8	Address hold time	10	—	ns	CL = 100 pF
	tAW8	Address setup time	30	—	ns	
$\overline{WR}$ , $\overline{RD}$	tCYC	System cycle time	(1)	—	ns	
	tCC	Strobe pulsewidth	220	—	ns	
D0 to D7	tDS8	Data setup time	120	—	ns	
	tDH8	Data hold time	10	—	ns	
	tACC8	$\overline{RD}$ access time	—	120	ns	
	tOH8	Output disable time	10	50	ns	

Note:  $t_{CYC} = 2t_c + t_{CC} + t_{CEA} + 75 > t_{ACV} + 245$ :  
memory control/movement control commands:  
 $= 4t_c + t_{CC} + 30$ :  
all other commands:

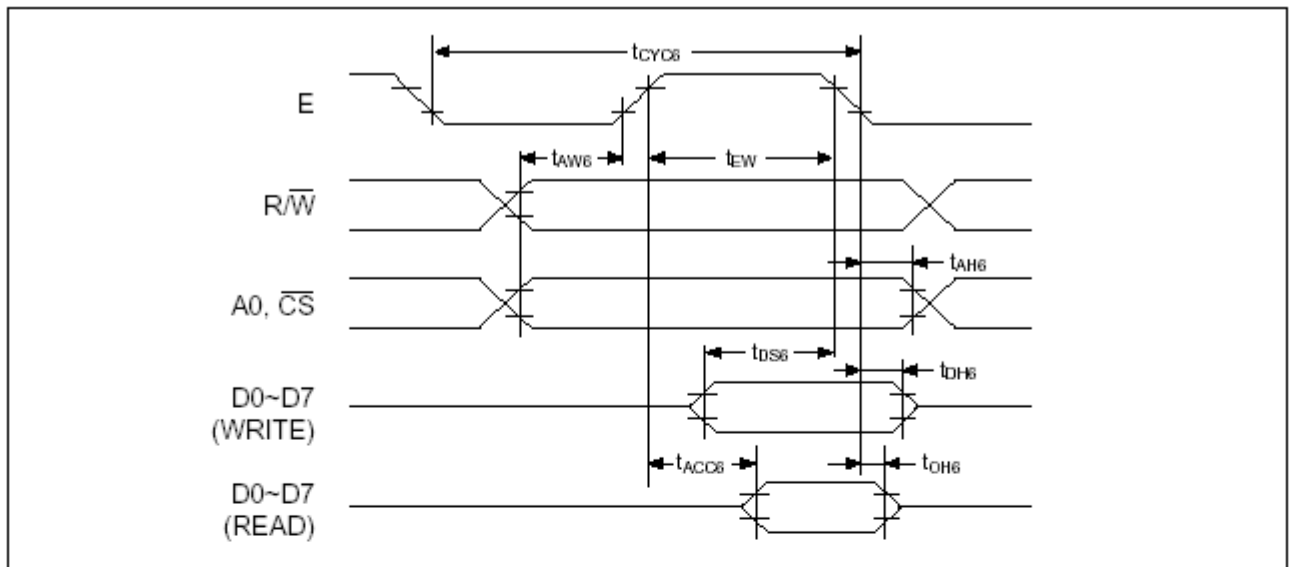
**System bus READ/WRITE timing II (6800)**

System bus READ/WRITE timing II (6800)

 $T_a = -20 \text{ to } 75^\circ\text{C}$ 

Signal	Symbol	Parameter	Rating		Unit	Condition
			min	max		
A0, $\overline{\text{CS}}$ R/ $\overline{\text{W}}$	tAH6	Address hold time	10	—	ns	CL=100pF+1TTL pF
	tAW6	Address setup time	30	—	ns	
	tCYC6	System cycle time	(1)	—	ns	
D0 to D7	tDS6	Data setup time	120	—	ns	
	tDH6	Data hold time	10	—	ns	
	tACC6	Access time	—	120	ns	
	tOH6	Output disable time	10	50	ns	
E	tEW	Enable pulse width	220	—	ns	

**Note:** (1)  $t_{CYC6} = 2t_c + t_{EW} + t_{CEA} + 75 > t_{ACV} + 245$ :  
 memory control/movement control commands:  
 $= 4t_c + t_{EW} + 30$ :  
 all other commands:

1.  $t_{CYC6}$  means a cycle of ( $\overline{\text{CS}}$ ,E) not E alone.

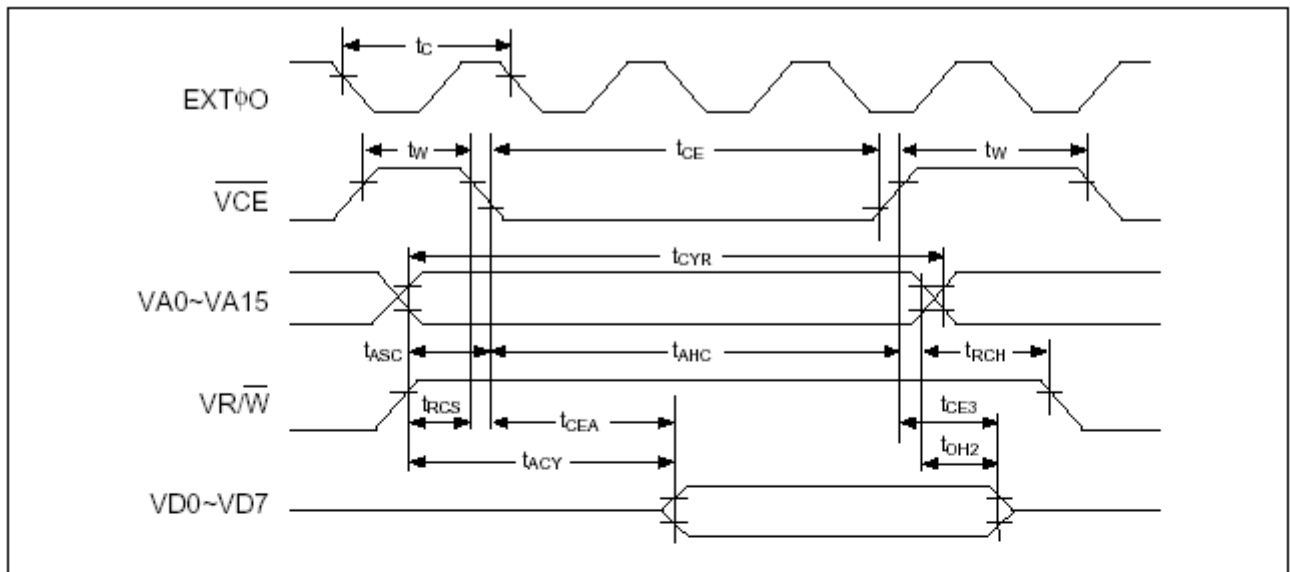

**Display memory READ timing**

Display memory READ timing

 $T_a = -20 \text{ to } 75^\circ\text{C}$ 

Signal	Symbol	Parameter	Rating		Unit	Condition
			min	max		
EXT $\phi 0$	$t_c$	Clock cycle	100	—	ns	CL = 100pF +1TTL
$\overline{\text{VCE}}$	$t_w$	$\overline{\text{VCE}}$ high level pulse width	$t_c - 40$	—	ns	
	$t_{CE}$	$\overline{\text{VCE}}$ low level pulse width	$2t_c - 40$	—	ns	
VA0 to VA15	$t_{CYR}$	Read cycle time	(1)	—	ns	
	$t_{ASC}$	$\overline{\text{VCE}}$ address setup time (fall)	$t_c - 45$	—	ns	
	$t_{AHC}$	$\overline{\text{VCE}}$ address hold time (fall)	$2t_c - 40$	—	ns	
$\overline{\text{VR/W}}$	$t_{RCS}$	$\overline{\text{VCE}}$ read cycle setup time (fall)	$t_c - 45$	—	ns	
	$t_{RCH}$	$\overline{\text{VCE}}$ read cycle hold time (fall)	$t_c/2 - 35$	—	ns	
VD0 to VD7	$t_{ACV}$	Address access time	—	(2)	ns	
	$t_{CEA}$	$\overline{\text{VCE}}$ access time	—	(3)	ns	
	$t_{OH2}$	Output data hold time	0	—	ns	
	$t_{CE2}$	$\overline{\text{VCE}}$ data off time	0	—	ns	

- Note:**
1.  $t_{CYR} = 3t_c$
  2.  $t_{ACV} = 3t_c - 120$
  3.  $t_{CEA} = 2t_c - 120$

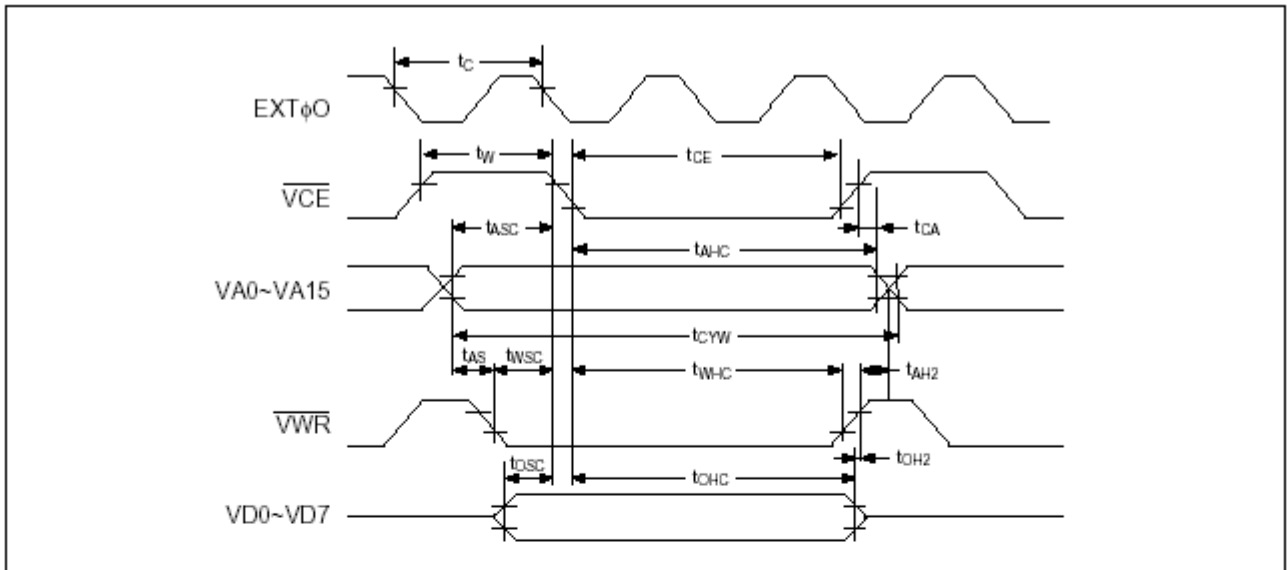
**Display memory WRITE timing**

Display memory WRITE timing

Ta = -20 to 75°C

Signal	Symbol	Parameter	Rating		Unit	Condition
			min	max		
EXT φ0	tc	Clock cycle	100	—	ns	CL = 100pF +1TTL
VCE	tw	VCE high level pulse width	tc-40	—	ns	
	tce	VCE low level pulse width	2tc-40	—	ns	
VA0 to VA15	tcyw	Write cycle time	3tc	—	ns	
	tahc	VCE address hold time (fall)	2tc-40	—	ns	
	tasc	VCE address setup time (fall)	tc-55	—	ns	
	tca	VCE address hold time (rise)	5	—	ns	
	tas	VR/W address setup time (fall)	0	—	ns	
	tah2	VR/W address hold time (rise)	15	—	ns	
VR/W	twsc	VCE write setup time (fall)	tc-55	—	ns	
	twhc	VCE write hold time (fall)	tc2-40	—	ns	
VD0 to VD7	tdsc	VCE data input setup time (fall)	twsc-10	—	ns	
	tdhc	VCE data input hold time (fall)	2tc-30	—	ns	
	tdh2	VR/W data hold time (rise)	10*	50	ns	

\* Lines VD0 to VD7 are latched.

## 2. DISPLAY CONTROL OUTPUT TIMING

### LCD control timing

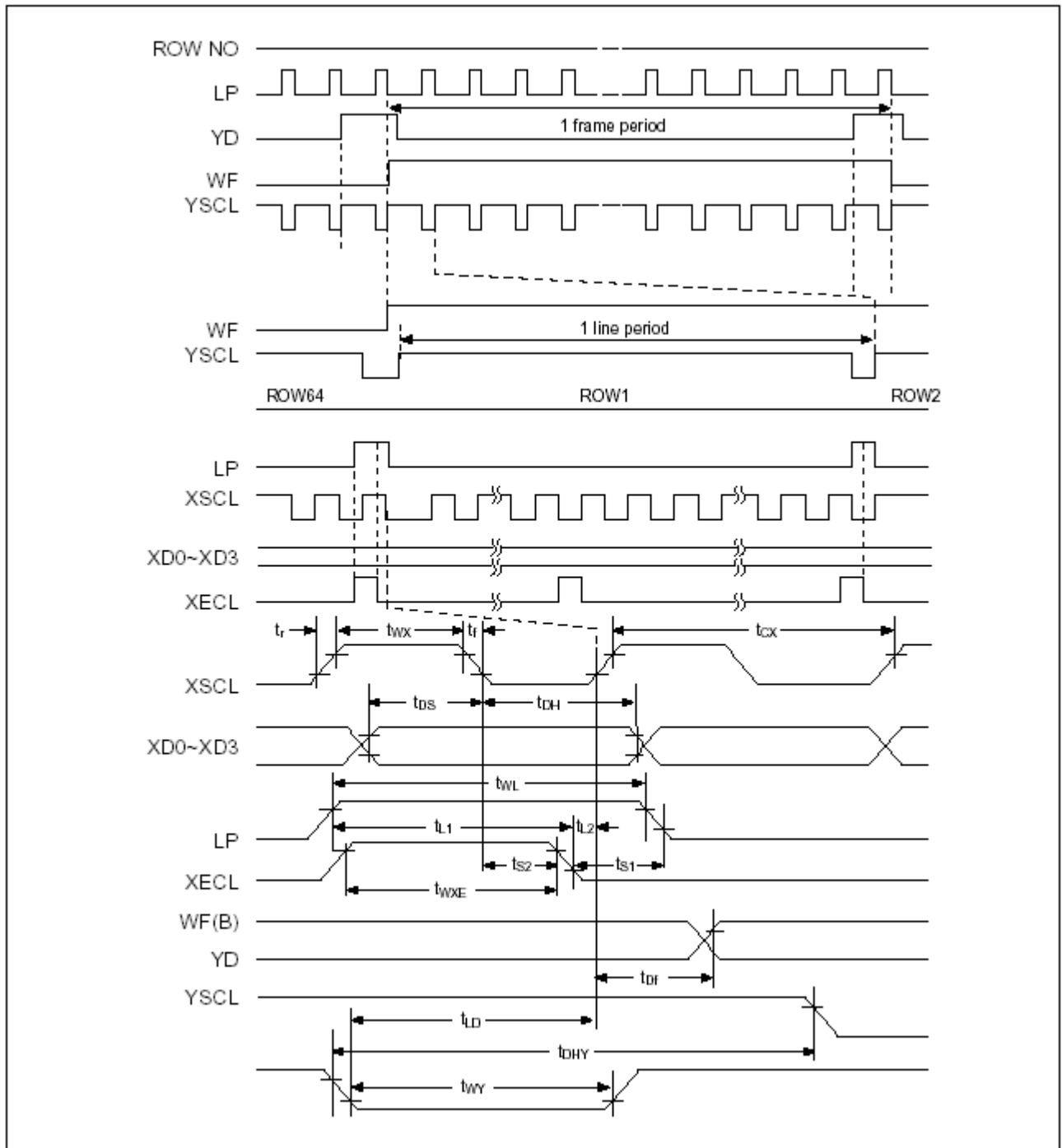

LCD control timing

Ta = -20 to 75°C

Signal	Symbol	Parameter	Rating		Unit	Condition
			min	max		
EXT $\phi$ 0	tc	Clock cycle	100	—	ns	VDD = 5.0V ±10% CL=150F
	tr	VCE high level pulse width	—	35	ns	
	tr	VCE low level pulse width	—	35	ns	
XSCL	tcX	Shift clock cycle time	4tc	—	ns	
	twX	XSCL clock pulse width	tcX2-80	—	ns	
XD0 to XD3	tDH	X-data hold time	tcX2-100	—	ns	
	tDS	X-data setup time	tcX2-100	—	ns	
LP	tLS	Latch data setup time	tcX2-100	—	ns	
	tWL	LP signal pulse width	tcX4-80	—	ns	
XECL	tL1	XECL setup time	tcX3-100	—	ns	
	tL2	XECL data hold time	tc-30	—	ns	
	ts1	Enable setup time	tc-30	—	ns	
	ts1	Enable delay time	tc-30	—	ns	
	twXE	XECL clock pulse width	tcX3-80	—	ns	
WF	tDF	Time allowance of WF delay	—	100	ns	
YSCL	tLD	LP delay time against YSCL	tcX4-100	—	ns	
	twY	YSCL clock pulse width	tcX4-80	—	ns	
YD	tDHY	Y-data hold time	tcX6-100	—	ns	

JEWEL

### 3. OSCILLATOR TIMING

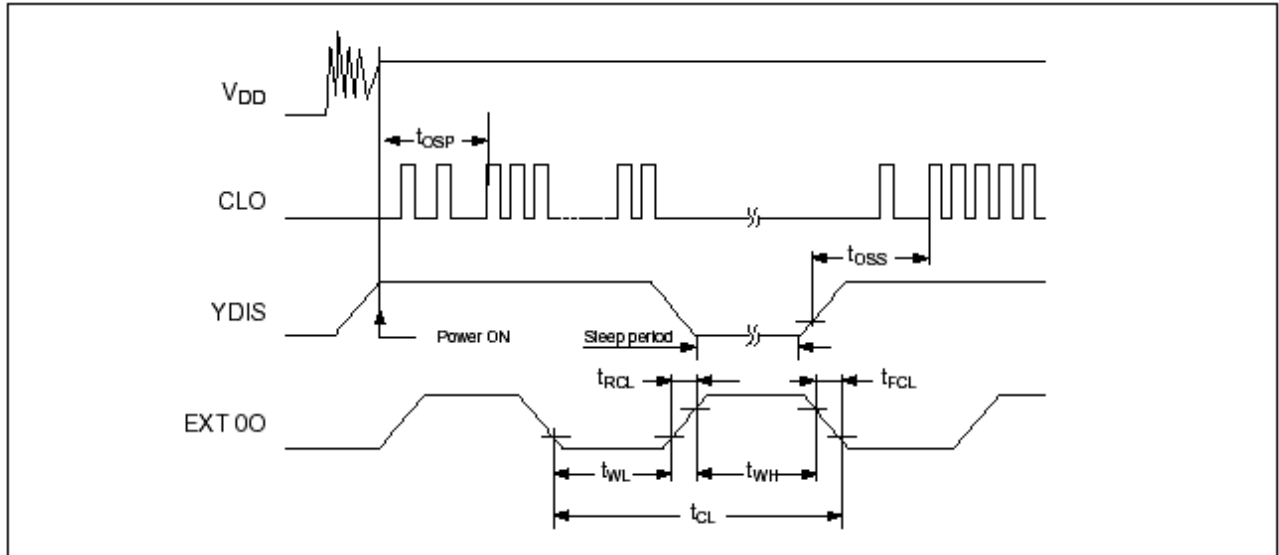

Oscillator timing

Ta = -20 to 75°C

Signal	Symbol	Parameter	Rating		Unit	Condition
			min	max		
CLO	tOSP	Time to stable CLO output after power ON	—	3	ms	RES = H 20 pF
	tOSS	Time to stable CLO output after sleep OFF	—	1	ms	
EXT00	tRCL	External clock rise time	—	15	ns	
	tFCL	External clock fall time	—	15	ns	
	tWH	External clock high-pulse width	Note 1	Note 2	ns	
	tWL	External clock low-pulse width	Note 1	Note 2	ns	
	tCL	External clock cycle	100	—	ns	

1.  $(t_C - t_{RCL} - t_{FCL}) \times 475/1000 < t_{WH}, t_{WL}$

2.  $(t_C - t_{RCL} - t_{FCL}) \times 525/1000 > t_{WH}, t_{WL}$



#### 4. SLEEP IN COMMAND TIMING

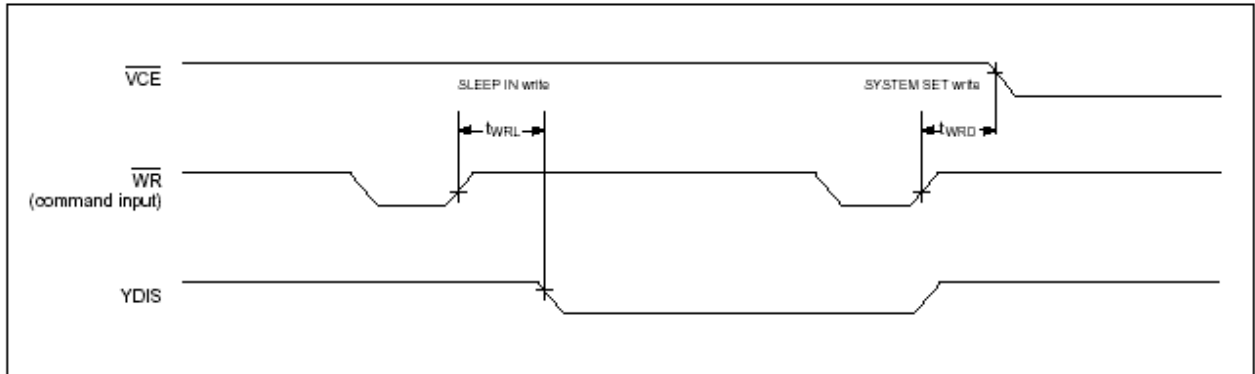

SLEEP IN command timing

Ta = -20 to 75°C

Signal	Symbol	Parameter	VDD = 4.5 to 5.5V		VDD = 2.7 to 4.5V		Unit	Condition
			min	max	min	max		
$\overline{WR}$	tWRD	$\overline{VCE}$ falling-edge delay time	See note 1	—	See note 1	—	ns	CL = 100 pF
	tWRL	YDIS falling-edge delay time	—	See note 2	—	See note 2	ns	

**Notes:**

1.  $t_{WRD} = 18t_C + t_{OSS} + 40$  ( $t_{OSS}$  is the time delay from the sleep state until stable operation)
2.  $t_{WRL} = 36t_C \times [TC/R] \times [L/F] + 70$

JHEM



### 5.EXTERNAL OSCILLATOR SIGNAL

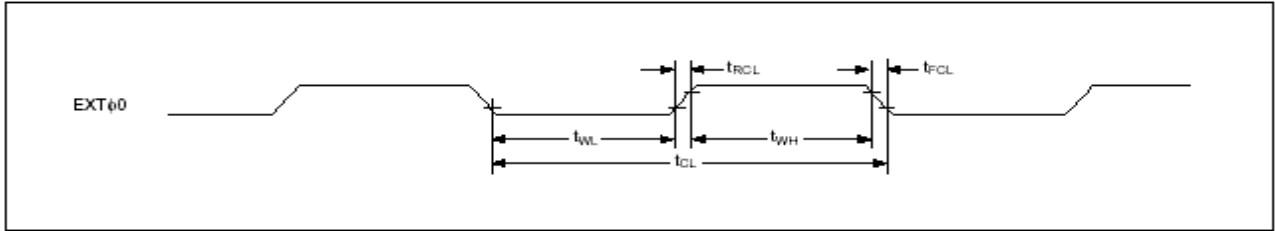

External oscillator signal timing

Ta = -20 to 75°C

Signal	Symbol	Parameter	VDD = 4.5 to 5.5V		VDD = 2.7 to 4.5V		Unit	Condition
			min	max	min	max		
EXT φ0	tRCL	External clock rise time	—	15	—	15	ns	
	tFCL	External clock fall time	—	15	—	15	ns	
	tWH	External clock HIGH-level pulsewidth	See note 1	See note 2	See note 1	See note 2	ns	
	tWL	External clock LOW-level pulsewidth	See note 1	See note 2	See note 1	See note 2	ns	
	tC	External clock period	100	—	125	—	ns	

**Notes:**

- $(t_c - t_{RCL} - t_{FCL}) \times \frac{475}{1000} < t_{WH}, t_{WL}$
- $(t_c - t_{RCL} - t_{FCL}) \times \frac{525}{1000} > t_{WH}, t_{WL}$

### 7.3 APPLICATION OF LCM

#### ■Circuit Block Diagram

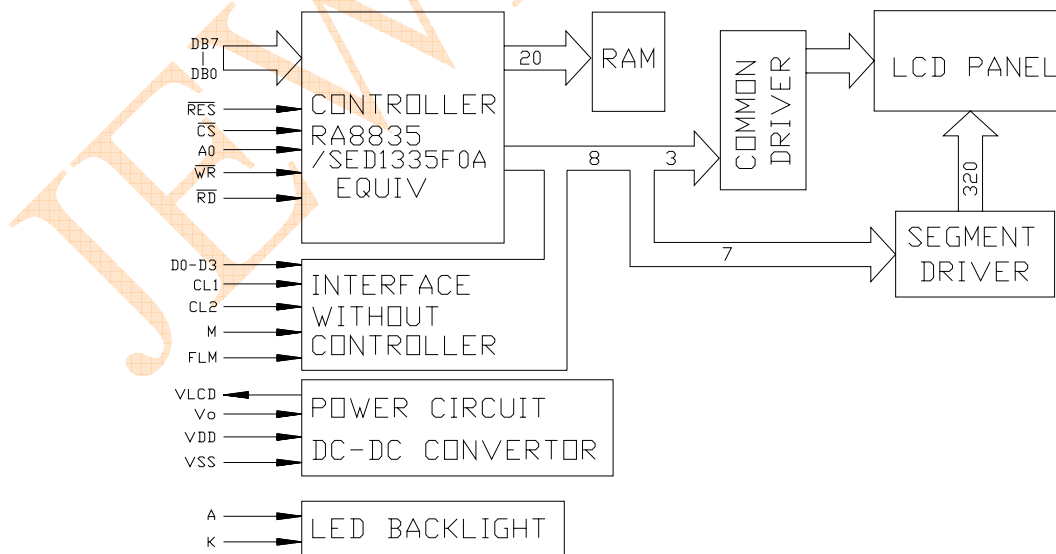



**Table 1. The Command Set**

Class	Command	Code											Hex	Command Description	Command Read Parameters	
		RD	WR	A0	D7	D6	D5	D4	D3	D2	D1	D0			No. of Bytes	Section
System control	SYSTEM SET	1	0	1	0	1	0	0	0	0	0	0	40	Initialize device and display	8	3.2.1
	SLEEP IN	1	0	1	0	1	0	1	0	0	1	1	53	Enter standby mode	0	3.2.2
Display control	DISP ON/OFF	1	0	1	0	1	0	1	1	0	0	D	58, 59	Enable and disable display and display flashing	1	3.3.1
	SCROLL	1	0	1	0	1	0	0	0	1	0	0	44	Set display start address and display regions	10	3.3.2
	CSRFORM	1	0	1	0	1	0	1	1	1	0	1	5D	Set cursor type	2	3.3.3
	CGRAM ADR	1	0	1	0	1	0	1	1	1	0	0	5C	Set start address of character generator RAM	2	3.3.6
	CSRDIR	1	0	1	0	1	0	0	1	1	CD	CD	4C to 4F	Set direction of cursor movement	0	3.3.4
	HDOT SCR	1	0	1	0	1	0	1	1	0	1	0	5A	Set horizontal scroll position	1	3.3.7
	OVLAY	1	0	1	0	1	0	1	1	0	1	1	5B	Set display overlay format	1	3.3.5
Drawing control	CSRW	1	0	1	0	1	0	0	0	1	1	0	46	Set cursor address	2	3.4.1
	CSRR	1	0	1	0	1	0	0	0	1	1	1	47	Read cursor address	2	3.4.2
Memory control	MWRITE	1	0	1	0	1	0	0	0	0	1	0	42	Write to display memory	—	3.5.1
	MREAD	1	0	1	0	1	0	0	0	0	1	1	43	Read from display memory	—	3.5.2

**Notes:**

- In general, the internal registers of the RA8835/SED1335FOA are modified as each command parameter is input. However, the microprocessor does not have to set all the parameters of a command and may send a new command before all parameters have been input. The internal registers for the parameters that have been input will have been changed but the remaining parameter registers are unchanged.
 

2-byte parameters (where two bytes are treated as one data item) are handled as follows:

  - CSRW, CSRR: Each byte is processed individually. The microprocessor may read or write just the low byte of the cursor address.
  - SYSTEM SET, SCROLL, CGRAM ADR: Both parameter bytes are processed together. If the command is changed after half of the parameter has been input, the single byte is ignored.
- APL and APH are 2-byte parameters, but are treated as two 1-byte parameters.



## 7.5 SYSTEM CONTROL COMMANDS

### 7.5.1 SYSTEM SET

Initializes the device, sets the window sizes, and selects the LCD interface format. Since the command sets the basic operating parameters of the RA8835

/SED1335F0A an incorrect SYSTEM SET command may cause other commands to operate incorrectly.

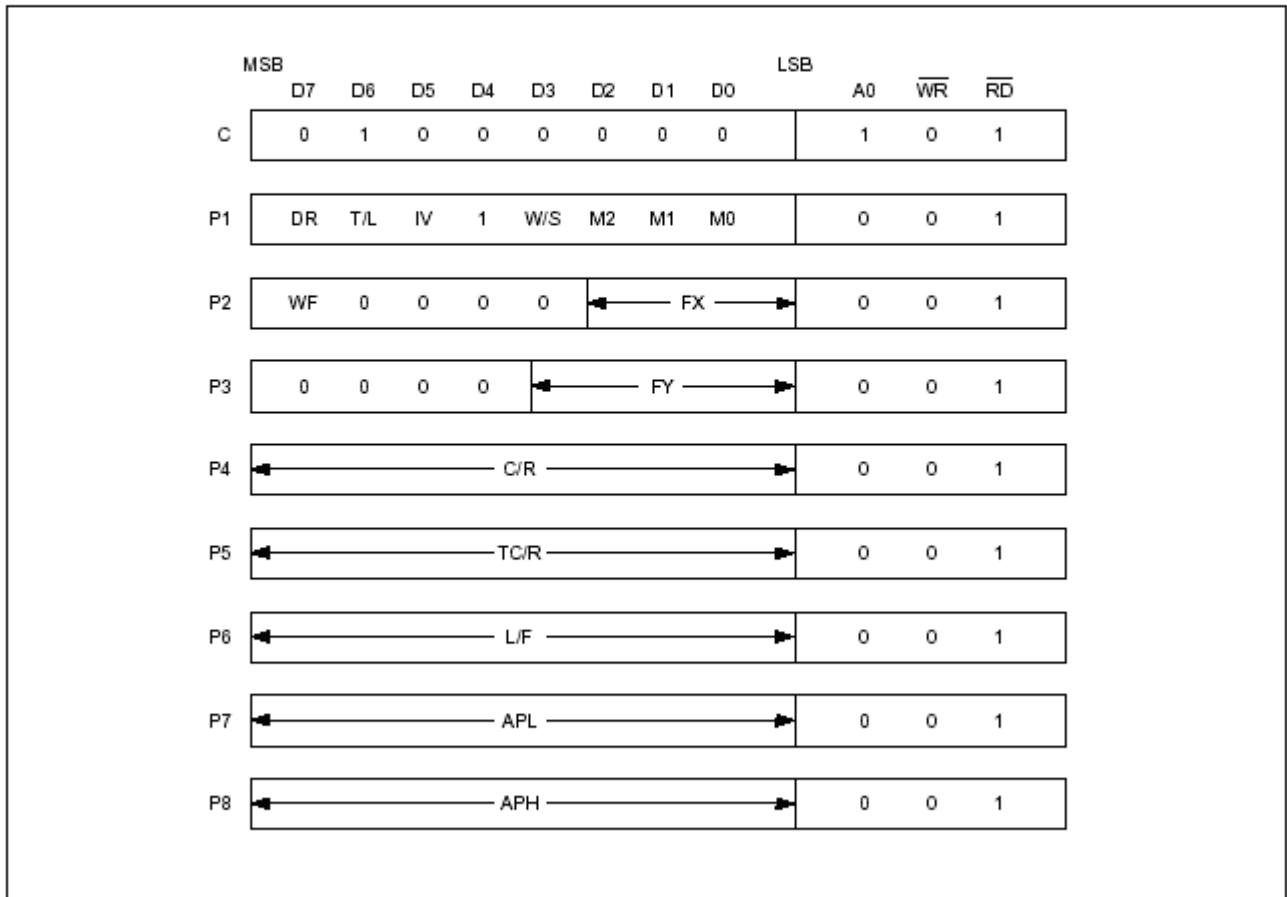

SYSTEM SET instruction



#### 7.5.1.1 C

This control byte performs the following:

1. Resets the internal timing generator
2. Disables the display
3. Cancels sleep mode

Parameters following P1 are not needed if only canceling sleep mode.

#### 7.5.1.2 M0

Selects the internal or external character generator ROM. The internal character generator ROM contains 160, 5×7 pixel characters. These characters are fixed at fabrication by the metalization mask. The external character generator ROM can contain up to 256 user-defined characters.

- M0 = 0:** Internal CG ROM  
**M0 = 1:** External CG ROM

Note that if the CG ROM address space overlaps the display memory address space, that portion of the display memory cannot be written to.

#### 7.5.1.3 M1

Selects the CG RAM area for user-definable characters. The CG RAM codes are selected from the 64 codes shown in Figure 59.

- M1 = 0:** CG RAM1; 32 char

The CG RAM1 and CG RAM2 address spaces are not contiguous, the CG RAM1 address space is treated

as character generator RAM, and the CG RAM2 address space is treated as character generator ROM.

- M1 = 1:** 64 char CG RAM + CG RAM2

The CG RAM1 and CG RAM2 address spaces are contiguous and are both treated as character generator RAM.

#### 7.5.1.4 M2

Selects the height of the character defined in external CG ROM and CG RAM. Characters more than 16 pixels high can be displayed by creating a bitmap for each portion of each character and using the SED1330F/1335F/1336F's graphics mode to reposition them.

- M2 = 0:** 8-pixel character height (2716 or equivalent ROM)  
**M2 = 1:** 16-pixel character height (2732 or equivalent ROM)

#### 7.5.1.5 W/S

Selects the LCD drive method.

- W/S = 0:** Single-panel drive  
**W/S = 1:** Dual-panel drive

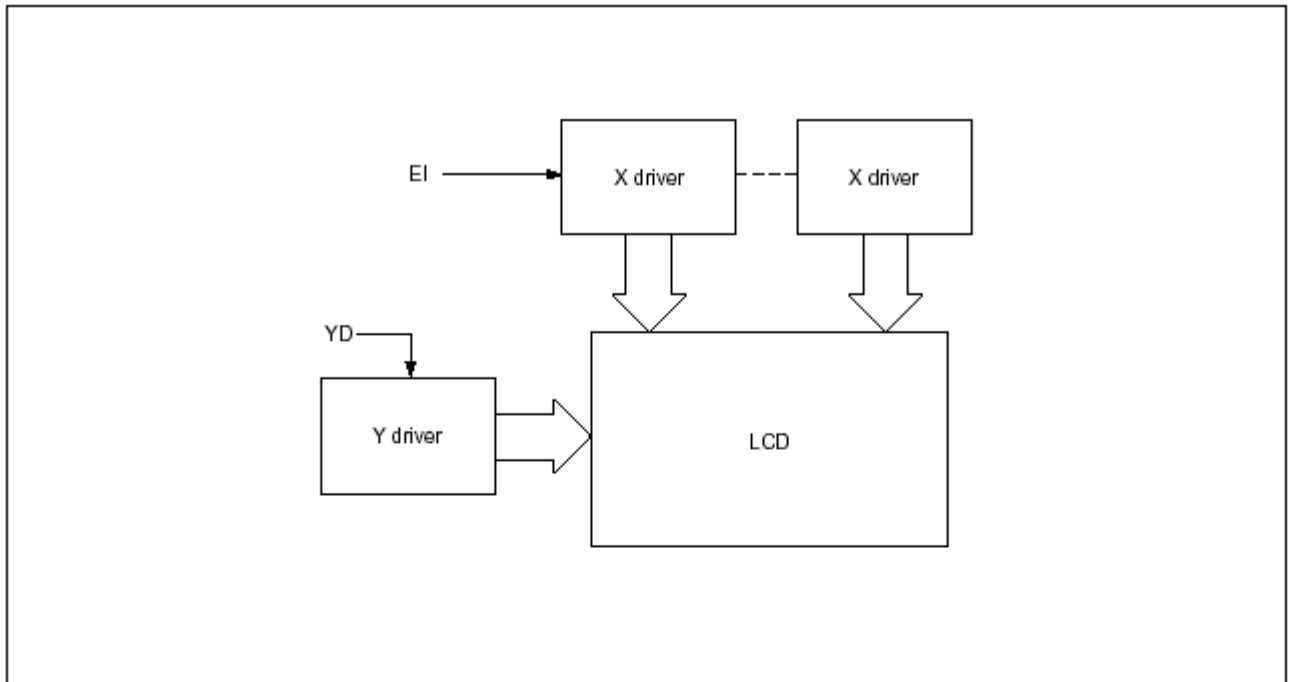

Single-panel display

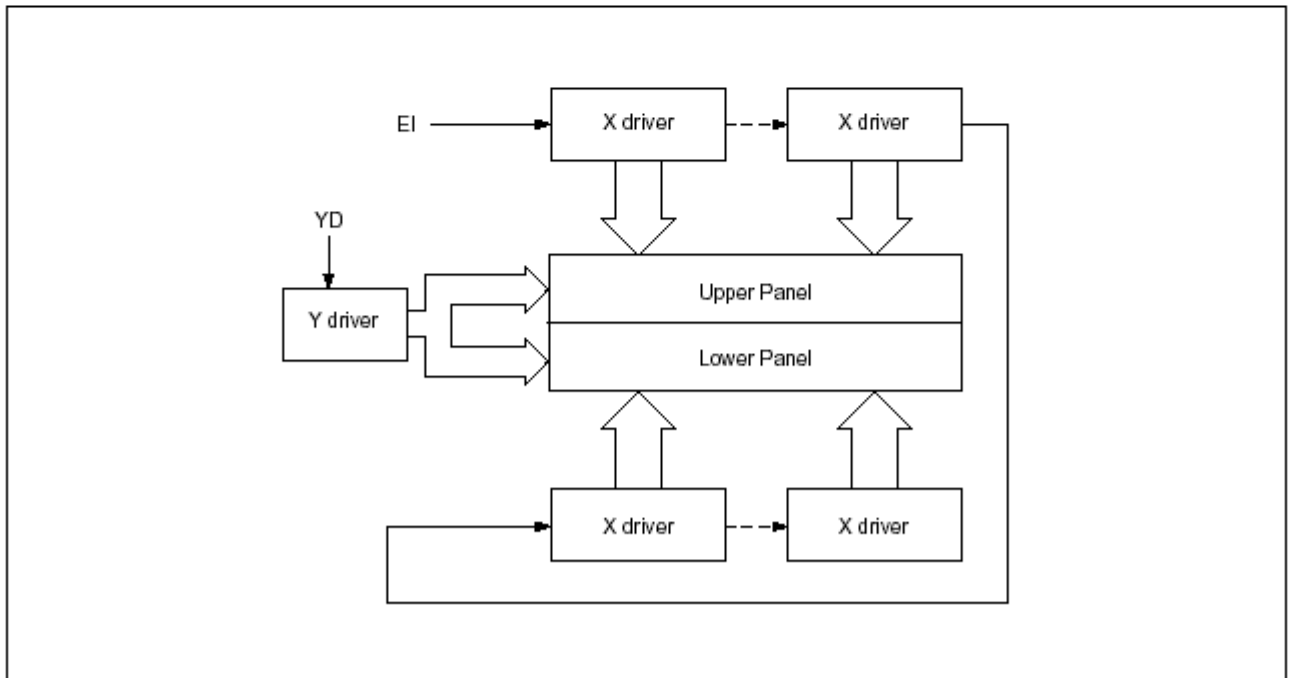

Dual-panel display

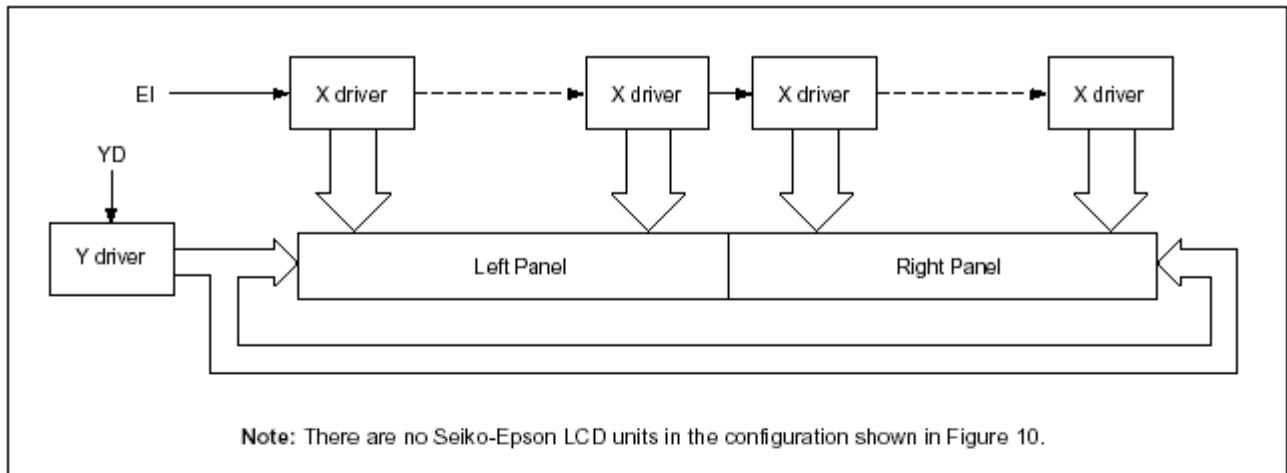

Left-and-right two-panel display

**Table 3. LCD parameters**

Parameter	W/S = 0		W/S = 1	
	IV = 1	IV = 0	IV = 1	IV = 0
C/R	C/R	C/R	C/R	C/R
TC/R	TC/R	TC/R (see note 1)	TC/R	TC/R
L/F	L/F	L/F	L/F	L/F
SL1	00H to L/F	00H to L/F + 1 (see note 2)	(L/F) / 2	(L/F) / 2
SL2	00H to L/F	00H to L/F + 1 (see note 2)	(L/F) / 2	(L/F) / 2
SAD1	First screen block	First screen block	First screen block	First screen block
SAD2	Second screen block	Second screen block	Second screen block	Second screen block
SAD3	Third screen block	Third screen block	Third screen block	Third screen block
SAD4	Invalid	Invalid	Fourth screen block	Fourth screen block
Cursor movement range	Continuous movement over whole screen		Above-and-below configuration: continuous movement over whole screen	

**Notes:**

1. See table 31 (page 105) for further details on setting the C/R and TC/R parameters when using the HDOT SCR command.
2. The value of SL when IV = 0 is equal to the value of SL when IV = 1, plus one.



### 7.5.1.6 IV

Screen origin compensation for inverse display. IV is usually set to 1.

The best way of displaying inverted characters is to Exclusive-OR the text layer with the graphics background layer. However, inverted characters at the top or left of the screen are difficult to read as the character origin is at the top-left of its bitmap and there are no background pixels either above or to the left of these characters.

The IV flag causes the RA8835/SED1335F0A to offset the text screen against the graphics back layer by one vertical pixel. Use the horizontal pixel scroll function (HDOT SCR) to shift the text screen 1 to 7 pixels to the right. All characters will then have the necessary surrounding background pixels that ensure easy reading of the inverted characters.

See Section 5.5 for information on scrolling.

- IV = 0:** Screen top-line correction
- IV = 1:** No screen top-line correction (no offset)

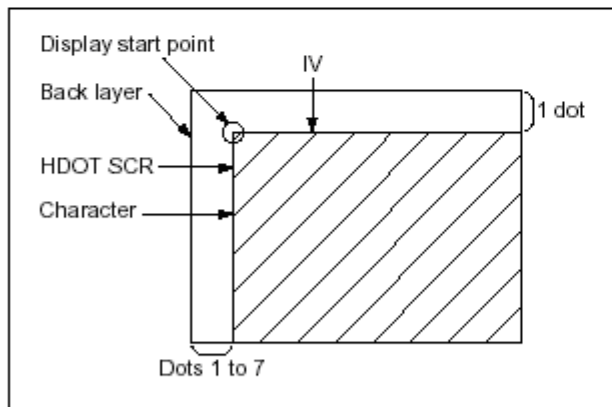

IV and HDOT SCR adjustment

### 7.5.1.7 T/L

Selects TV or LCD mode. When TV mode is selected, the TV sync generator circuit is ON.

- T/L = 0:** LCD mode
- T/L = 1:** TV mode

### 7.5.1.8 DR

Selects output of an additional shift-clock cycle for every 64 pixels. The extra cycles are required for correct operation of the enable chain when using a two-panel display.

- DR = 0:** Normal operation
- DR = 1:** Additional shift-clock cycles

### 7.5.1.9 FX

Sets the width, in pixels, of the character field. The character width in pixels is equal to FX + 1, where FX can range from 00 to 07H inclusive. If data bit 3 is set (FX is in the range 08 to 0FH) and an 8-pixel font is used, a space is inserted between characters. Note that the maximum character width in TV mode is eight pixels.

Table 4. Horizontal character size selection

HEX	FX				[FX] character width (pixels)
	D3	D2	D1	D0	
00	0	0	0	0	1
01	0	0	0	1	2
↓	↓	↓	↓	↓	↓
07	0	1	1	1	8

Since the RA8835/SED1335F0A handles display data in 8-bit units, characters larger than 8 pixels wide must be formed from 8-pixel segments. As Figure 12 shows, the remainder of the second eight bits are not displayed. This also applies to the second screen layer.

In graphics mode, the normal character field is also eight pixels. If a wider character field is used, any remainder in the second eight bits is not displayed.



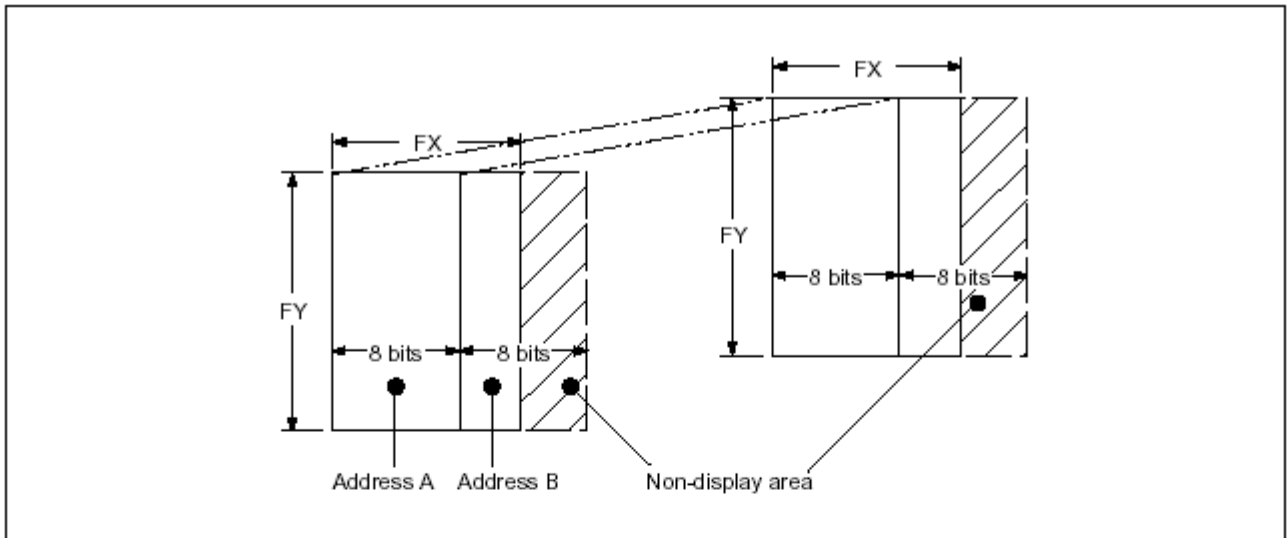

FX and FY display addresses

#### 7.5.1.10 WF

Selects the AC frame drive waveform period. WF is usually set to 1.

**WF = 0:** 16-line AC drive

**WF = 1:** two-frame AC drive

In two-frame AC drive, the WF period is twice the frame period.

In 16-line AC drive, WF inverts every 16 lines.

Although 16-line AC drive gives a more readable display, horizontal lines may appear when using high LCD drive voltages or at high viewing angles.

#### 7.5.1.11 FY

Sets the height, in pixels, of the character. The height in pixels is equal to FY + 1.

FY can range from 00 to 0FH inclusive.

Set FY to zero (vertical size equals one) when in graphics mode.

Table 5. Vertical character size selection

HEX	FY				[FY] character height (pixels)
	D3	D2	D1	D0	
00	0	0	0	0	1
01	0	0	0	1	2
↓	↓	↓	↓	↓	↓
07	0	1	1	1	8
↓	↓	↓	↓	↓	↓
0E	1	1	1	0	15
0F	1	1	1	1	16



### 7.5.1.12 C/R

Sets the address range covered by one display line, that is, the number of characters less one, multiplied by the number of horizontal bytes per character.

C/R can range from 0 to 239.

For example, if the character width is 10 pixels, then the address range is equal to twice the number of

characters, less 2. See Section 9.1.1 for the calculation of C/R.

[C/R] cannot be set to a value greater than the address range. It can, however, be set smaller than the address range, in which case the excess display area is blank. The number of excess pixels must not exceed 64.

**Table 6. Display line address range**

C/R									[C/R] bytes per display line
HEX	D7	D6	D5	D4	D3	D2	D1	D0	
00	0	0	0	0	0	0	0	0	1
01	0	0	0	0	0	0	0	1	2
↓	↓	↓	↓	↓	↓	↓	↓	↓	↓
4F	0	1	0	0	1	1	1	1	80
↓	↓	↓	↓	↓	↓	↓	↓	↓	↓
EE	1	1	1	0	1	1	1	0	239
EF	1	1	1	0	1	1	1	1	240

### 7.5.1.13 TC/R

Sets the length, including horizontal blanking, of one line. The line length is equal to TC/R + 1, where TC/R can range from 0 to 255.

TC/R must be greater than or equal to C/R + 4. Provided this condition is satisfied, [TC/R] can be set

according to the equation given in section 9.1.1 in order to hold the frame period constant and minimize jitter for any given main oscillator frequency,  $f_{OSC}$ .

**Table 7. Line length selection**

TC/R									[TC/R] line length (bytes)
HEX	D7	D6	D5	D4	D3	D2	D1	D0	
00	0	0	0	0	0	0	0	0	1
01	0	0	0	0	0	0	0	1	2
↓	↓	↓	↓	↓	↓	↓	↓	↓	↓
52	0	1	0	1	0	0	1	0	83
↓	↓	↓	↓	↓	↓	↓	↓	↓	↓
FE	1	1	1	1	1	1	1	0	255
FF	1	1	1	1	1	1	1	1	256

### 7.5.1.14 L/F

Sets the height, in lines, of a frame. The height in lines is equal to L/F + 1, where L/F can range from 0 to 255.

If W/S is set to 1, selecting two-screen display, the number of lines must be even and L/F must, therefore, be an odd number.

**Table 8. Frame height selection**

HEX	L/F								[L/F] lines per frame
	D7	D6	D5	D4	D3	D2	D1	D0	
00	0	0	0	0	0	0	0	0	1
01	0	0	0	0	0	0	0	1	2
↓	↓	↓	↓	↓	↓	↓	↓	↓	↓
7F	0	1	1	1	1	1	1	1	128
↓	↓	↓	↓	↓	↓	↓	↓	↓	↓
FE	1	1	1	1	1	1	1	0	255
FF	1	1	1	1	1	1	1	1	256

**Table 9. Frame heights and compatible LCD units**

Number of lines [LF]	Panel Duty Cycle
64	1/64
128	1/64

**Table 10. Horizontal address range**

Hex code				[AP] addresses per line
APH		APL		
0	0	0	0	0
0	0	0	1	1
↓	↓	↓	↓	↓
0	0	5	0	80
↓	↓	↓	↓	↓
F	F	F	E	$2^{16} - 2$
F	F	F	F	$2^{16} - 1$

### 7.5.1.15 AP

Defines the horizontal address range of the virtual screen. APL is the least significant byte of the address.

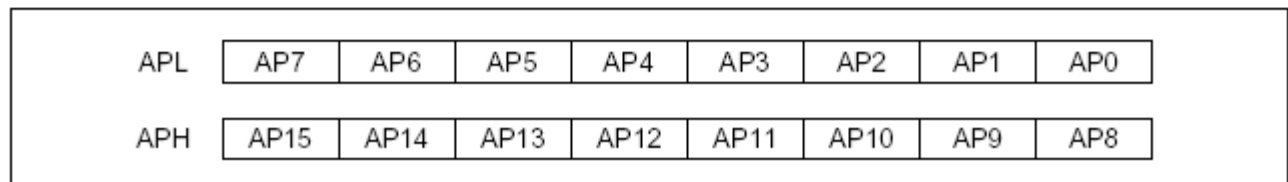

AP parameters

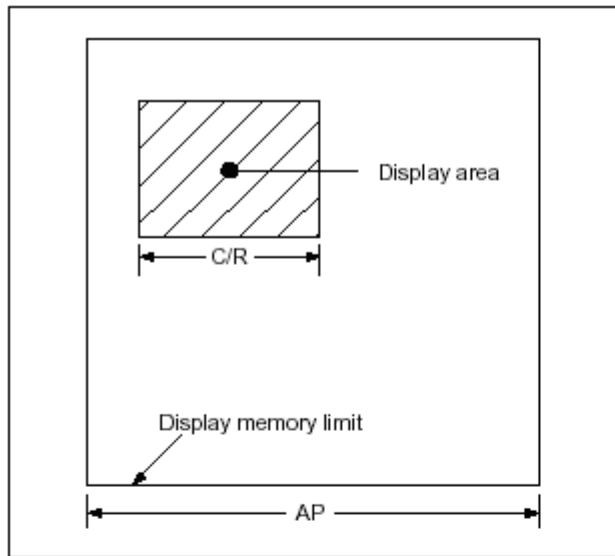

AP and C/R relationship

### 7.5.2 SLEEP IN

Places the system in standby mode. This command has no parameter bytes. At least one blank frame after receiving this command, the RA8835/SED1335FOA halts all internal operations, including the oscillator, and enters the sleep mode. Blank data is sent to the X-drivers, and the Y-drivers have their bias supplies turned off by the YDIS signal. Using the YDIS signal to disable the Y-drivers guards against any spurious displays.

The internal registers of the RA8835/SED1335FOA maintain their values during the sleep mode. The display memory control pins maintain their logic levels to ensure that the display memory is not corrupted.

The RA8835/SED1335FOA can be removed from the sleep state by sending the SYSTEM SET command with only the P1 parameter. The DISP ON command should be sent next to enable the display.

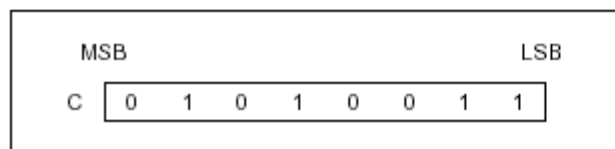

SLEEP IN instruction

1. The YDIS signal goes LOW between one and two frames after the SLEEP IN command is received. Since YDIS forces all display driver outputs to go to the deselected output voltage, YDIS can be used as a power-down signal for the LCD unit. This can be done by having YDIS turn off the relatively high-power LCD drive supplies at the same time as it blanks the display.
2. Since all internal clocks in the RA8835/SED1335FOA are halted while in the sleep state, a DC voltage will be applied to the LCD panel if the LCD drive supplies remain on.

If reliability is a prime consideration, turn off the LCD drive supplies before issuing the SLEEP IN command.

3. Note that, although the bus lines become high impedance in the sleep state, pull-up or pull-down resistors on the bus line will force these lines to a known state.

### 7.5.3 Display Control Commands

#### 7.5.3.1 DISP ON/OFF

Turns the whole display on or off. The single-byte parameter enables and disables the cursor and layered screens, and sets the cursor and screen flash rates. The cursor can be set to flash over one character or over a whole line.

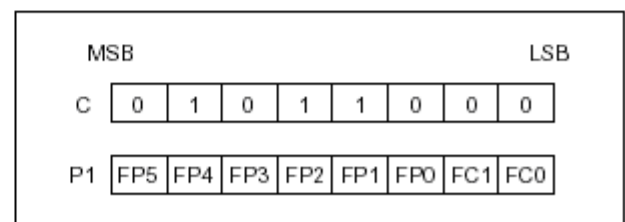

DISP ON/OFF parameters

### 7.5.3.1.1 D

Turns the display ON or OFF. The D bit takes precedence over the FP bits in the parameter.

- D = 0: Display OFF
- D = 1: Display ON

### 7.5.3.1.2 FC

Enables/disables the cursor and sets the flash rate. The cursor flashes with a 70% duty cycle (ON/OFF).

**Table 11. Cursor flash rate selection**

FC1	FC0	Cursor display	
0	0	OFF (blank)	
0	1	ON	No flashing
1	0		Flash at $f_{FR}/32$ Hz (approx. 2 Hz)
1	1		Flash at $f_{FR}/64$ Hz (approx. 1 Hz)

**Note:** As the MWRITE command always enables the cursor, the cursor position can be checked even when performing consecutive writes to display memory while the cursor is flashing.

### 7.5.3.1.3 FP

Each pair of bits in FP sets the attributes of one screen block, as follows.

**Table 12. Screen block attribute selection**

FP1	FP0	First screen block (SAD1)	
FP3	FP2	Second screen block (SAD2, SAD4). See note.	
FP5	FP4	Third screen block (SAD3)	
0	0	OFF (blank)	
0	1	ON	No flashing
1	0		Flash at $f_{FR}/32$ Hz (approx. 2 Hz)
1	1		Flash at $f_{FR}/4$ Hz (approx. 16 Hz)

**Note:** If SAD4 is enabled by setting W/S to 1, FP3 and FP2 control both SAD2 and SAD4. The attributes of SAD2 and SAD4 cannot be set independently.

### 7.5.3.2 SCROLL

#### 7.5.3.2.1 C

Sets the scroll start address and the number of lines per scroll block. Parameters P1 to P10 can be omitted if not required. The parameters must be entered sequentially as shown in Figure 17.

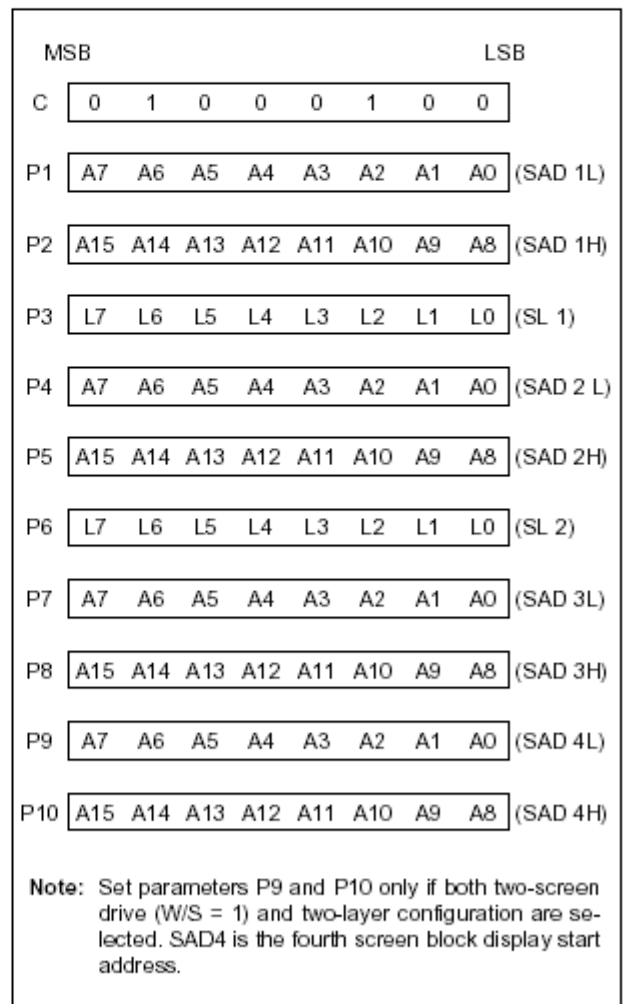

SCROLL instruction parameters

**Table 13. Screen block start address selection**

SL1, SL2									[SL] screen lines
HEX	L7	L6	L5	L4	L3	L2	L1	L0	
00	0	0	0	0	0	0	0	0	1
01	0	0	0	0	0	0	0	1	2
↓	↓	↓	↓	↓	↓	↓	↓	↓	↓
7F	0	1	1	1	1	1	1	1	128
↓	↓	↓	↓	↓	↓	↓	↓	↓	↓
FE	1	1	1	1	1	1	1	0	255
FF	1	1	1	1	1	1	1	1	256

### 7.5.3.2.2 SL1, SL2

SL1 and SL2 set the number of lines per scrolling screen. The number of lines is SL1 or SL2 plus one.

The relationship between SAD, SL and the display mode is described below.

**Table 14. Text display mode**

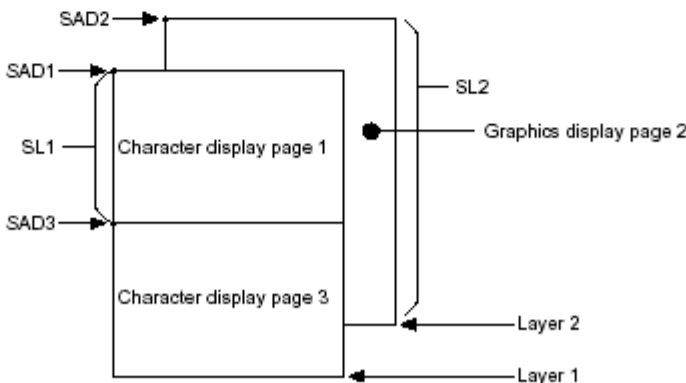
W/S	Screen	First Layer	Second Layer
0	First screen block	SAD1	SAD2
	Second screen block	SL1	SL2
	Third screen block (partitioned screen)	SAD3 (see note 1) Set both SL1 and SL2 to L/F + 1 if not using a partitioned screen.	
	Screen configuration example:		
			

(continued)

Table 14. Text display mode (continued)

W/S	Screen	First Layer	Second Layer
1	Upper screen	SAD1 SL1	SAD2 SL2
	Lower screen	SAD3 (see note 2)	SAD4 (see note 2)
	Set both SL1 and SL2 to $((L/F) / 2 + 1)$		
	Screen configuration example:		

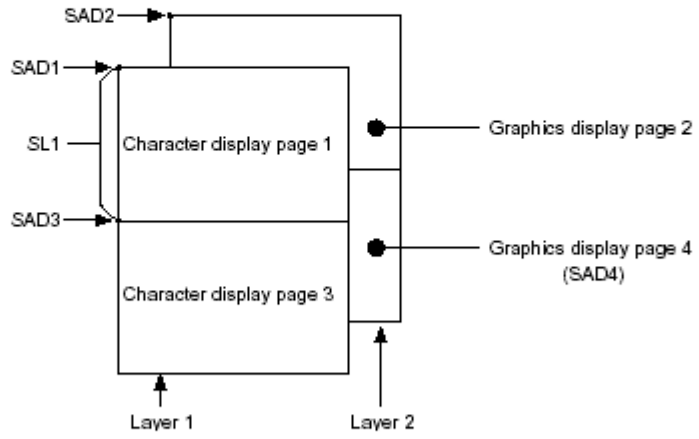

The diagram illustrates a screen configuration example. It shows a vertical stack of two 'Character display page' blocks: 'Character display page 1' on top and 'Character display page 3' on the bottom. To the left of these pages, arrows point to 'SAD1' and 'SAD3' for the top page, and 'SAD2' for the bottom page. A bracket labeled 'SL1' spans both pages. Below the pages, two arrows labeled 'Layer 1' and 'Layer 2' point upwards. To the right, two dots represent 'Graphics display page 2' and 'Graphics display page 4 (SAD4)'. Lines connect the SAD labels to their respective positions in the diagram.

Notes:

1. SAD3 has the same value as either SAD1 or SAD2, whichever has the least number of lines (set by SL1 and SL2).
2. Since the parameters corresponding to SL3 and SL4 are fixed by L/F, they do not have to be set in this mode.

JEWEL

**Table 15. Graphics display mode**

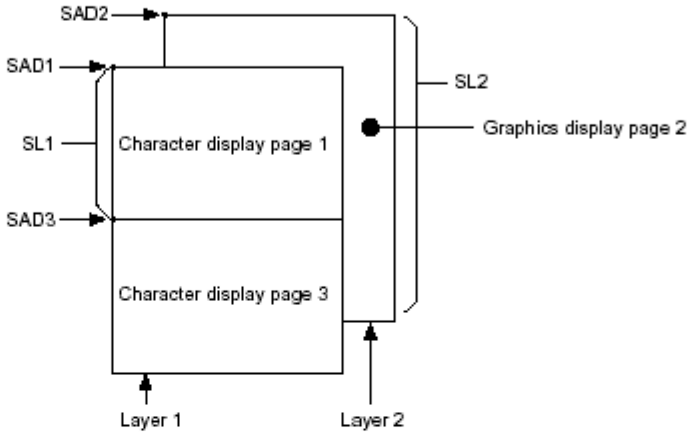
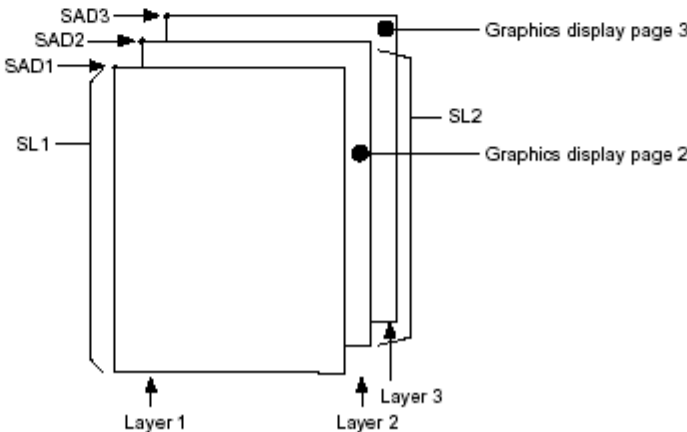
W/S	Screen	First Layer	Second Layer	Third Layer
0	Two-layer composition	SAD1 SL1	SAD2 SL2	
	Upper screen	SAD3 (see note 3) Set both SL1 and SL2 to L/F + 1 if not using a partitioned screen		
	Screen configuration example:			
				
0	Three-layer configuration	SAD1 SL1 = L/F + 1	SAD2 SL2 = L/F + 1	SAD3 —
	Screen configuration example:			
				

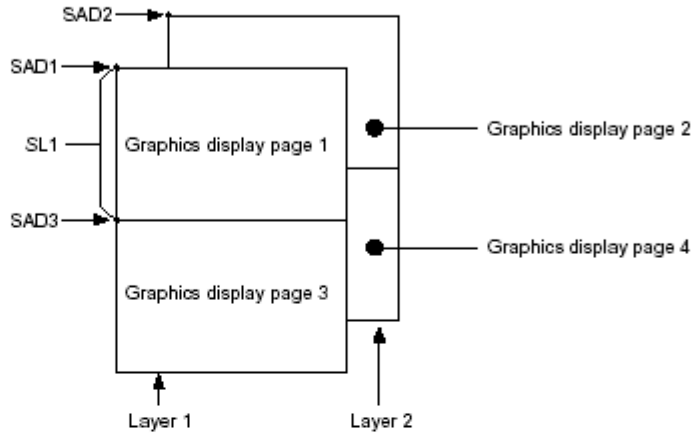
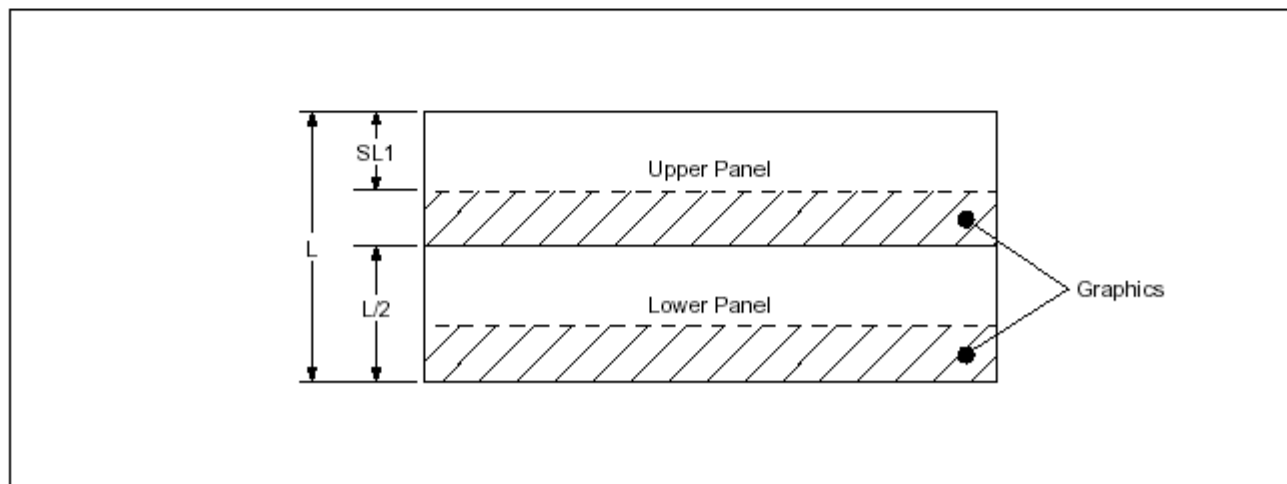

**Table 15. Graphics display mode (continued)**

W/S	Screen	First Layer	Second Layer	Third Layer
1	Upper screen	SAD1 SL1	SAD2 SL2	—
	Lower screen	SAD3 (see note 2)	SAD4 (see note 2)	—
	Set both SL1 and SL2 to $((L/F) / 2 + 1)$ Screen configuration example (see note 3):			
				

**Notes:**

- SAD3 has the same value as either SAD1 or SAD2, whichever has the least number of lines (set by SL1 and SL2).
- Since the parameters corresponding to SL3 and SL4 are fixed by L/F, they do not have to be set.
- If, and only if, W/S = 1, the differences between SL1 and  $(L/F + 1) / 2$ , and between SL2 and  $(L/F + 1) / 2$ , are blanked.



Two-panel display height

### 7.5.3.3 CSRFORM

Sets the cursor size and display mode. Although the cursor is normally only used in text displays, it may also be used in graphics displays when displaying special characters.

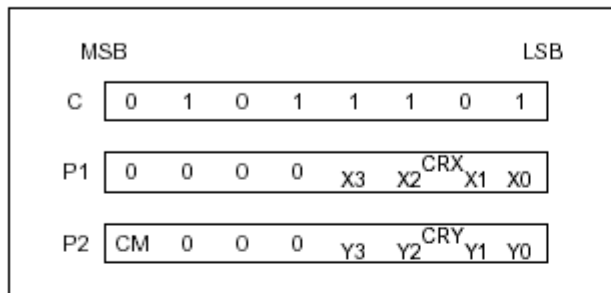

Figure 19. CSRFORM parameter bytes

#### 7.5.3.3.1 CRX

Sets the horizontal size of the cursor from the character origin. CRX is equal to the cursor size less one. CRX must be less than or equal to FX.

Table 16. Horizontal cursor size selection

HEX	CRX				[CRX] cursor width (pixels)
	X3	X2	X1	X0	
0	0	0	0	0	1
1	0	0	0	1	2
↓	↓	↓	↓	↓	↓
8	1	0	0	0	9
↓	↓	↓	↓	↓	↓
E	1	1	1	0	15
F	1	1	1	1	16

#### 7.5.3.3.2 CRY

Sets the location of an underscored cursor in lines, from the character origin. When using a block cursor, CRY sets the vertical size of the cursor from the character origin. CRY is equal to the number of lines less one.

Table 17. Cursor height selection

HEX	CRY				[CRY] cursor height (lines)
	Y3	Y2	Y1	Y0	
0	0	0	0	0	illegal
1	0	0	0	1	2
↓	↓	↓	↓	↓	↓
8	1	0	0	0	9
↓	↓	↓	↓	↓	↓
E	1	1	1	0	15
F	1	1	1	1	16

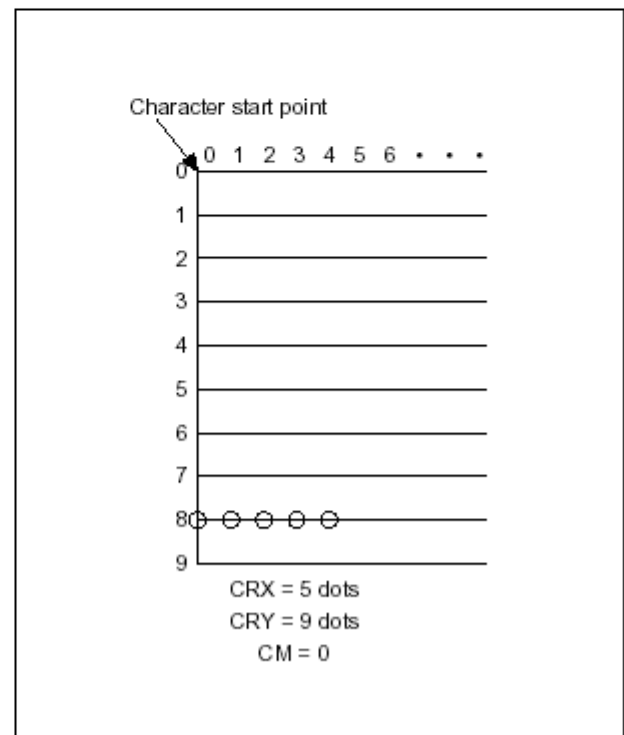

Cursor size and position

### 7.5.3.3.3 CM

Sets the cursor display mode. Always set CM to 1 when in graphics mode.

**CM = 0:** Underline cursor

**CM = 1:** Block cursor

### 7.5.3.4 CSRDIR

Sets the direction of automatic cursor increment. The cursor can move left or right one character, or up or down by the number of bytes specified by the address pitch, AP.

When reading from and writing to display memory, this automatic cursor increment controls the display memory address increment on each read or write.

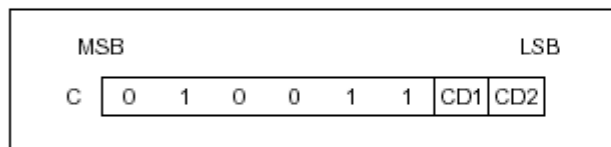

CSRDIR parameters

Table 18. Cursor shift direction

C	CD1	CD0	Shift direction
4CH	0	0	Right
4DH	0	1	Left
4EH	1	0	Up
4FH	1	1	Down

**Note:** Since the cursor moves in address units even if FX ≥ 9, the cursor address increment must be preset for movement in character units. See Section 5.3.

### 7.5.3.5 OVLAY

Selects layered screen composition and screen text/graphics mode.

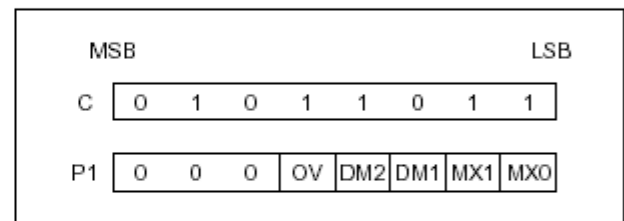

OVLAY parameter

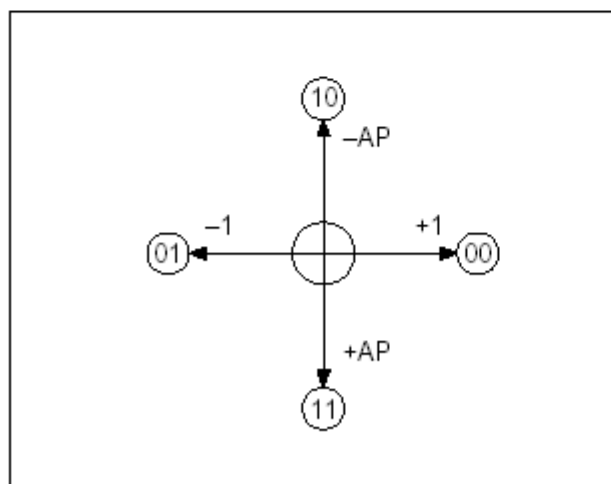

Cursor direction

#### 7.5.3.5.1 MX0, MX1

MX0 and MX1 set the layered screen composition method, which can be either OR, AND, Exclusive-OR or Priority-OR. Since the screen composition is organized in layers and not by screen blocks, when using a layer divided into two screen blocks, different composition methods cannot be specified for the individual screen blocks.

The Priority-OR mode is the same as the OR mode unless flashing of individual screens is used.

**Table 19. Composition method selection**

MX1	MX0	Function	Composition Method	Applications
0	0	$L1 \cup L2 \cup L3$	OR	Underlining, rules, mixed text and graphics
0	1	$(L1 \oplus L2) \cup L3$	Exclusive-OR	Inverted characters, flashing regions, underlining
1	0	$(L1 \cap L2) \cup L3$	AND	Simple animation, three-dimensional appearance
1	1	$L1 > L2 > L3$	Priority-OR	

**Notes:**

L1: First layer (text or graphics). If text is selected, layer L3 cannot be used.

L2: Second layer (graphics only)

L3: Third layer (graphics only)

JEWEL HILL

### 7.5.3.5.2 DM1, DM2

DM1 and DM2 specify the display mode of screen blocks 1 and 3, respectively.

**DM1/2 = 0:** Text mode

**DM1/2 = 1:** Graphics mode

**Note 1:** Screen blocks 2 and 4 can only display graphics.

**Note 2:** DM1 and DM2 must be the same, regardless of the setting of W/S.

### 7.5.3.5.3 OV

Specifies two- or three-layer composition in graphics mode.

**OV = 0:** Two-layer composition

**OV = 1:** Three-layer composition

Set OV to 0 for mixed text and graphics mode.

### 7.5.3.6 CGRAM ADR

Specifies the CG RAM start address.

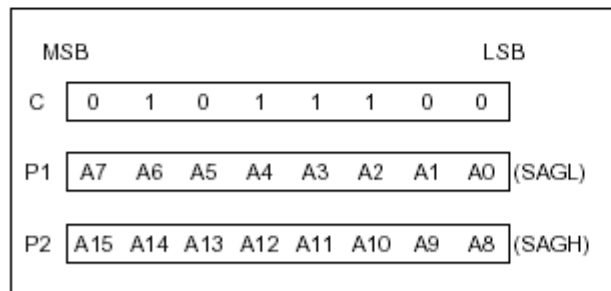

CGRAM ADR parameters

**Note:** See Section 6 for information on the SAG parameters.

### 7.5.3.7 HDOT SCR

While the scroll command only allows scrolling by characters, HDOT SCR allows the screen to be scrolled horizontally by pixels. HDOT SCR cannot be used on individual layers.

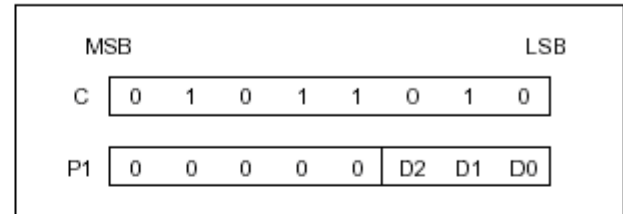

HDOT SCR parameters

#### 7.5.3.7.1 D0 to D2

Specifies the number of pixels to scroll. The C/R parameter has to be set to one more than the number of horizontal characters before using HDOT SCR. Smooth scrolling can be simulated if the controlling microprocessor repeatedly issues the HDOT SCR command to the RA8835/SED1335F0A. See Section 5.5 for more information on scrolling the display.

**Table 20. Scroll step selection**

HEX	P1			Number of pixels to scroll
	D2	D1	D0	
00	0	0	0	0
01	0	0	1	1
02	0	1	0	2
↓	↓	↓	↓	↓
06	1	1	0	6
07	1	1	1	7

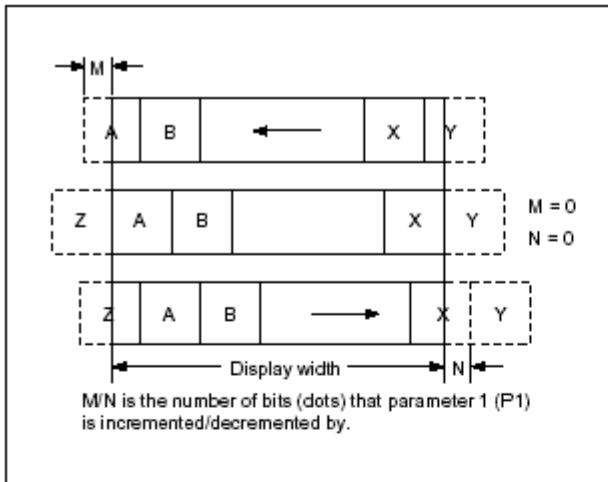

Horizontal scrolling

## 7.5.4 Drawing Control Commands

### 7.5.4.1 CSRW

The 16-bit cursor address register contains the display memory of the data at the cursor position as shown in Figure 28.

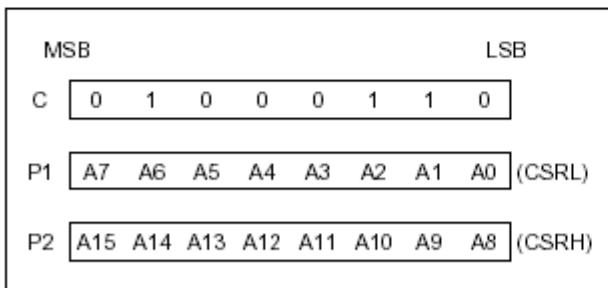

CSRW parameters

Note that the microprocessor cannot directly access the display memory.

The MREAD and MWRITE commands use the address in this register.

The cursor address register can only be modified by the CSRW command, and by the automatic increment after an MREAD or MWRITE command. It is not affected by display scrolling.

If a new address is not set, display memory accesses will be from the last set address or the address after previous automatic increments.

### 7.5.4.2 CSRR

Reads from the cursor address register. After issuing the command, the data read address is read twice, for the low byte and then the high byte of the register.

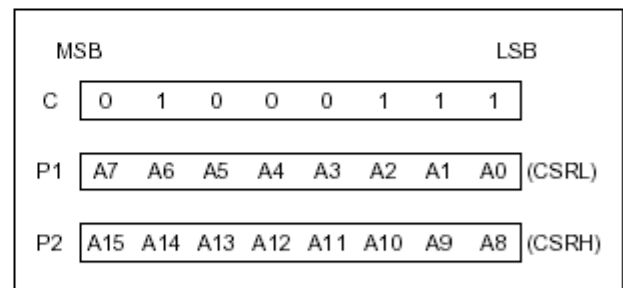

CSRR parameters



## 7.5.5 Memory Control Commands

### 7.5.5.1 MWRITE

The microprocessor may write a sequence of data bytes to display memory by issuing the MREAD command and then writing the bytes to the RA8835/SED1335F0A. There is no need for further MWRITE commands or for the microprocessor to update the cursor address register after each byte as the cursor address is automatically incremented by the amount set with CSRDIR, in preparation for the next data write.

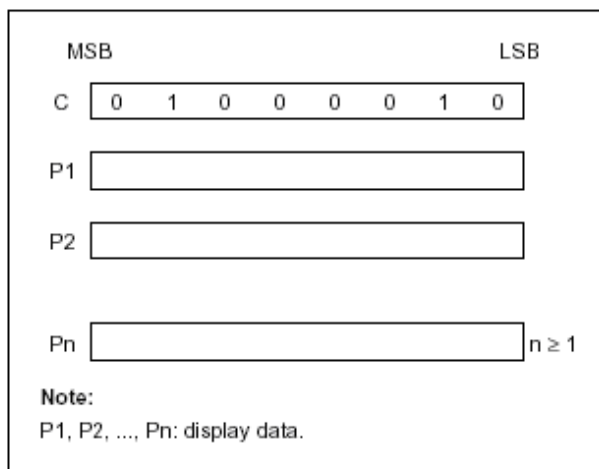

MWRITE parameters

### 7.5.5.2 MREAD

Puts the RA8835/SED1335F0A into the data output state. On the MREAD command, the display memory data at the cursor address is read into a buffer in the RA8835/SED1335F0A.

Each time the microprocessor reads the buffer, the cursor address is incremented by the amount set by CSRDIR and the next data byte fetched from memory, so a sequence of data bytes may be read without further MREAD commands or by updating the cursor address register.

If the cursor is displayed, the read data will be from two positions ahead of the cursor.

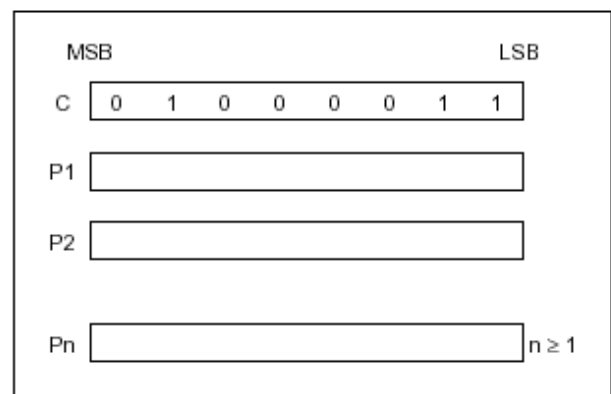

MREAD parameters

JEWEL

## 8. ELECTRO-OPTICAL CHARACTERISTICS

Item	Symbol	Condition	Temp	Min	Typ.	Max	Units	Note
LCD driving voltage	V <sub>LCD</sub>	$\theta = \phi = 0$	0°C	-	25.5	-	V	NOTE1
			25°C	24.5	25	25.5		
			50°C	-	24.5	-		
Response Time	Rise Time (Tr)	$\theta = \phi = 0$	0°C	---	---	--	msec	NOTE2
	Decay Time (Tf)			---	---	---		
	Rise Time (Tr)		25°C	---	225	340		
	Decay Time (Tf)			---	240	360		
	Rise Time (Tr)		50°C	---	---	--		
	Decay Time (Tf)			---	---	--		
Contrast Ratio	Cr	$\theta = \phi = 0$	25°C	5	10	---	---	NOTE4

Viewing Angle Range	$\theta (\phi = 0^\circ)$ (6'')	$\phi = 90^\circ$ (3'')	$\phi = 180^\circ$ (12'')	$\phi = 270^\circ$ (9'')	備註
$\theta (25^\circ\text{C})$ CR $\geq$ 2	45	35	25	35	Deg NOTE3

● For panel only



• **Electro-Optical Characteristics Measuring Equipment(DMS501)**

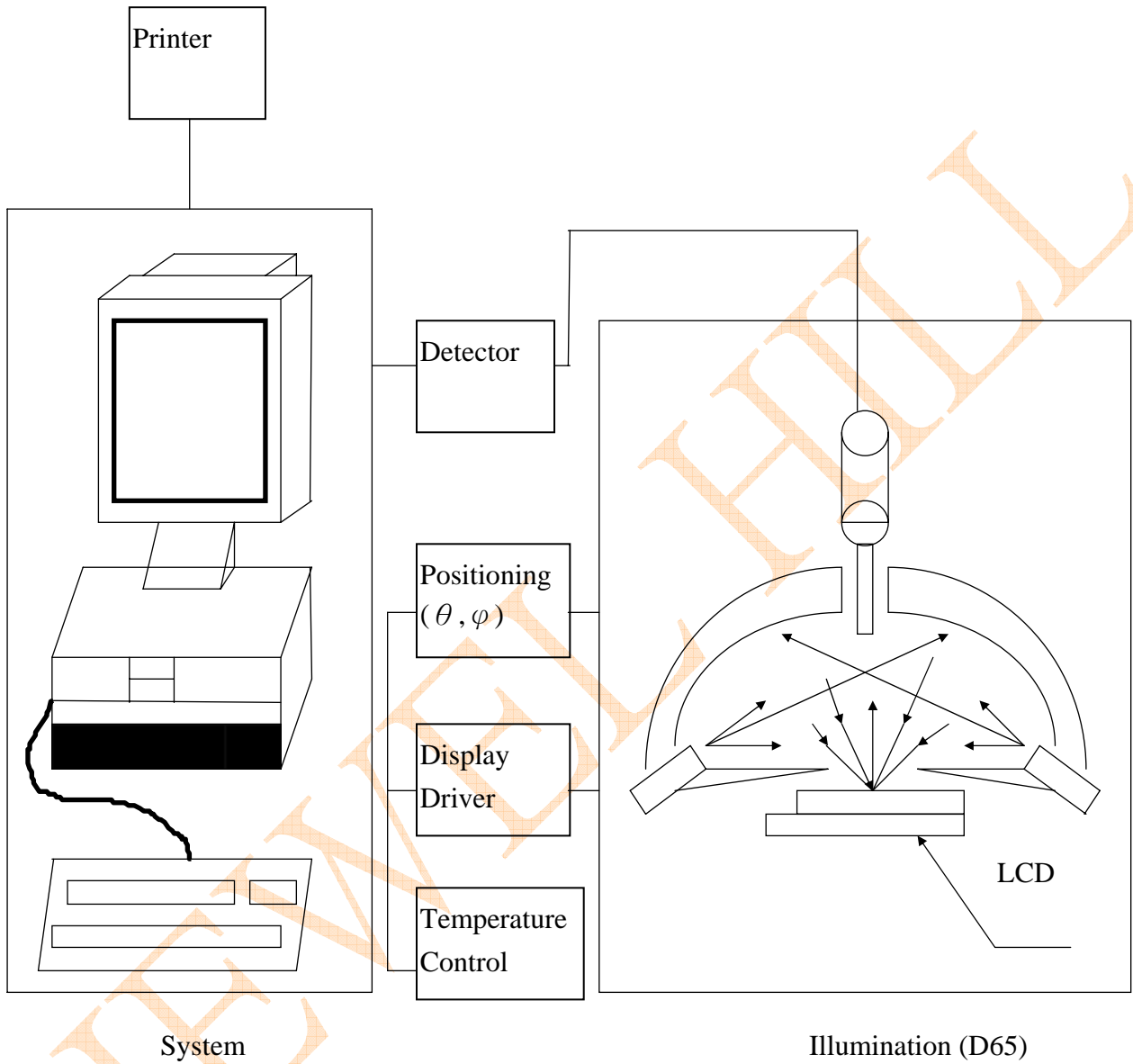

• **Note 1. Definition of Driving Voltage( Vlcd) :**

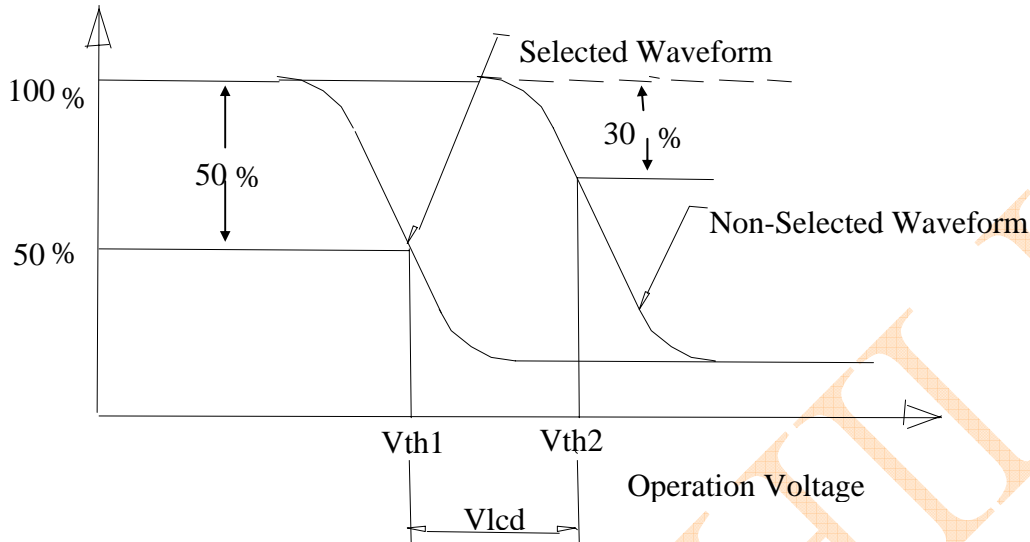

• **Note 2. Definition of Optical Response Time :**

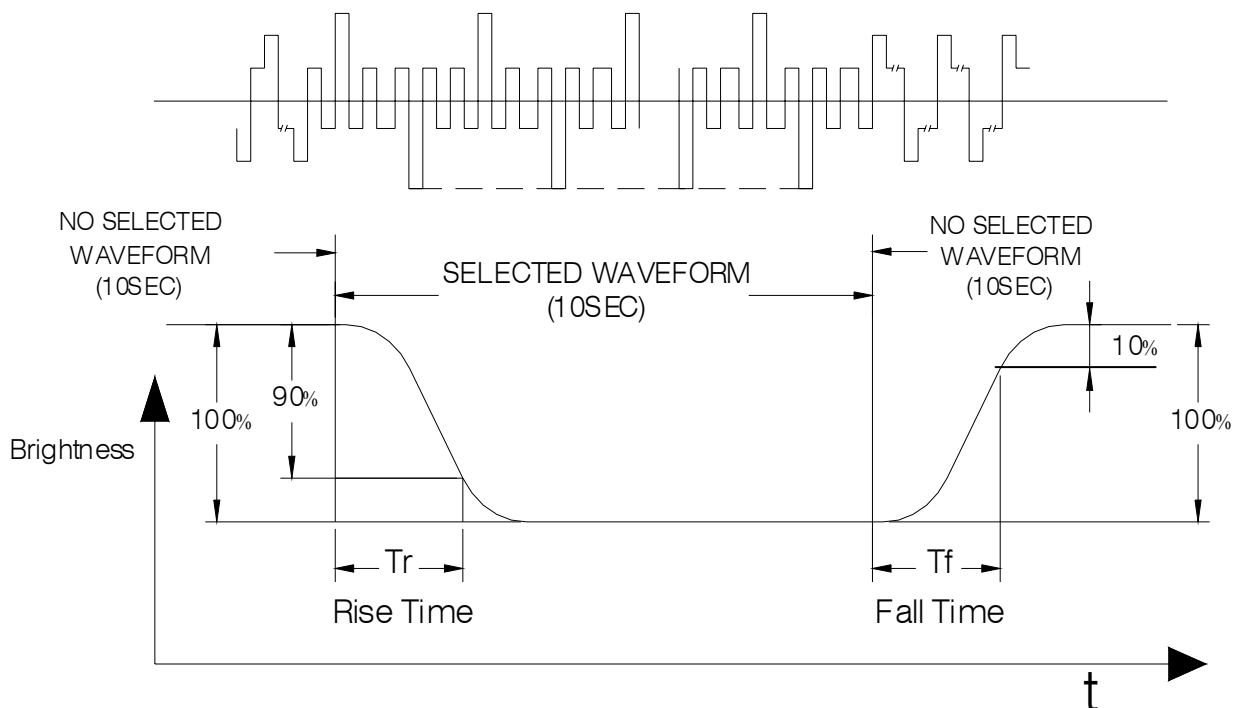

• **Note 3. Definition of Viewing Angle  $\theta$  and  $\phi$  :**

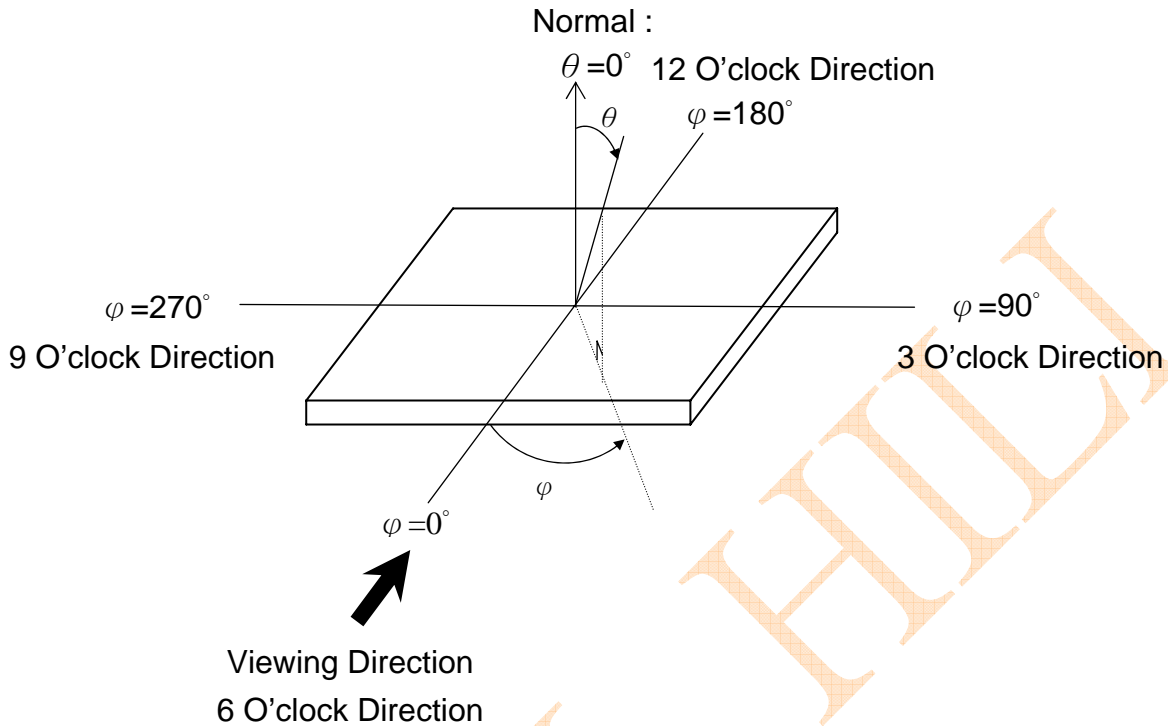

• **Note 4. Definition of Contrast ratio( CR) :**

$$CR = \frac{\text{Brightness of Non-selected Segment (B2)}}{\text{Brightness of Selected Segment (B1)}}$$

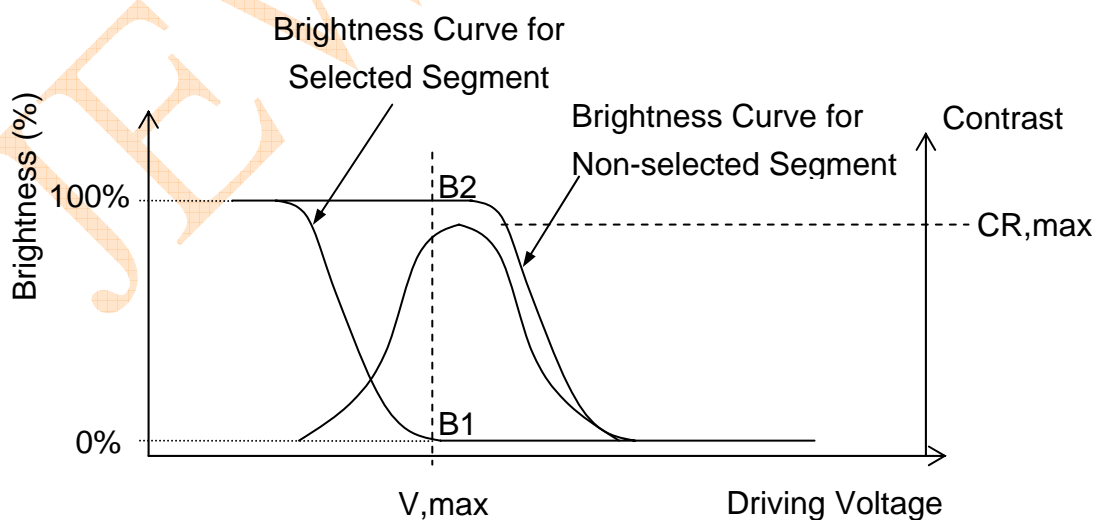

## 9. RELIABILITY

### A) MTBF

The LCD module shall be designed to meet a minimum MTBF value of 30000 hours with normal. (25°C in the room without sunlight)

### B) TESTS

NO.	ITEM	CONDITION	CRITERION
1	High Temperature Operating	70°C 120Hrs	<ul style="list-style-type: none"> <li>◦ No Defect Of Operational Function In Room Temperature Are Allowable.</li> <li>◦ IDD of LCM in Pre-and post-test should follow specification</li> </ul>
2	Low Temperature Operating	-20°C 120Hrs	
3	High Temperature/ Humidity Non-Operating	60°C ,90%RH ,120 Hrs	
4	High Temperature Non-Operating	80°C 120Hrs	
5	Low Temperature Non-Operating	-30°C 120Hrs	
6	Temperature Cycling Non-Operating	-20°C (30Min )↔ 60°C (30Min) 10 CYCLES	

Notes: Judgments should be made after exposure in room temperature for two hours.

## **10. PRECAUTIONS FOR USING LCD MODULES**

### **a) HANDLING PRECAUTIONS**

- (1) The display panel is made of glass. Do not subject it to a mechanical shock or impact by dropping it.
- (2) If the display panel is damaged and the liquid crystal substance leaks out, be sure not to get any in your mouth. If the substance contacts your skin or clothes, wash it off using soap and water.
- (3) Do not apply excessive force to the display surface or the adjoining areas since this may cause the color tone to vary.
- (4) The polarizer covering the display surface of the LCD module is soft and easily scratched. Handle this polarizer carefully.
- (5) If the display surface becomes contaminated, breathe on the surface and gently wipe it with a soft dry cloth. If it is heavily contaminated, moisten a cloth with one of the following solvents:
  - Isopropyl alcohol
  - Ethyl alcohol
- (6) Solvents other than those above mentioned may damage the polarizer.  
Especially, do not use the following:
  - Water
  - Ketone
  - Aromatic solvents
- (7) Extra care to minimize corrosion of the electrode. Water droplets, moisture condensation or a current flow in a high-humidity environment accelerates corrosion of the electrode.
- (8) Install the LCD Module by using the mounting holes. When mounting the LCD Module, make sure it is free of twisting, warping and distortion. In particular, do not forcibly pull or bend the I/O cable or the backlight cable.
- (9) Do not attempt to disassemble or process the LCD Module.
- (10) NC terminal should be open. Do not connect anything.
- (11) If the logic circuit power is off, do not apply the input signals.
- (12) To prevent destruction of the elements by static electricity, be careful to maintain an optimum work environment.
  - Be sure to ground the body when handling the LCD Module.
  - Tools required for assembling, such as soldering irons, must be properly grounded.
  - To reduce the amount of static electricity generated, do not conduct assembling and other work under dry conditions.

-The LCD Module is coated with a film to protect the display surface. Exercise care when peeling off this protective film since static electricity may be generated.

## **B) STORAGE CONDITIONS**

When storing, avoid the LCD module to be exposed to direct sunlight of fluorescent lamps. For stability, to keep it away from high temperature and high humidity environment (The best condition is :  $23\pm 5^{\circ}\text{C}$ ,  $45\pm 20\%\text{RH}$ ). ESD protection is necessary for long-term storage also.

## **C) OTHERS**

Liquid crystals solidify under low temperature (below the storage temperature range) leading to defective orientation or the generation of air bubbles (black or white). Air bubbles may also be generated if the module is subject to a low temperature.

If the LCD Module have been operating for a long time showing the same display patterns the display patterns may remain on the screen as ghost images and a slight contrast irregularity may also appear. A normal operating status can be recovered by suspending use for some time. It should be noted that this phenomenon does not adversely affect performance reliability.

To minimize the performance degradation of the LCD Module resulting from destruction caused by static electricity etc. exercise care to avoid holding the following sections when handling the modules.

- Exposed area of the printed circuit board.
- Terminal electrode sections.

## **11. Using LCD modules**

### **11.1 LIQUID CRYSTAL DISPLAY MODULES**

LCD is composed of glass and polarizer. Pay attention to the following items when handling.

- (1) Please keep the temperature within specified range for use and storage. Polarization degradation, bubble generation or polarizer peel-off may occur with high temperature and high humidity.
- (2) Do not touch, push or rub the exposed polarizers with anything harder than a HB pencil lead (glass, tweezers, etc).
- (3) N-hexane is recommended for cleaning the adhesives used to attach front/rear polarizers and reflectors made of organic substances, which will be damaged by chemicals such as acetone, toluene, toluene, ethanol and isopropyl alcohol.
- (4) When the display surface becomes dusty, wipe gently with absorbent cotton or other soft material like chamois soaked in petroleum ether. Do not scrub hard to avoid damaging the display surface.
- (5) Wipe off saliva or water drops immediately, contact with water over a long period of time may cause deformation or color fading.
- (6) Avoid contacting oil and fats.
- (7) Condensation on the surface and contact with terminals due to cold will damage, stain or polarizers. After products are tested at low temperature they must be warmed up in a container before coming is contacting with room temperature air.
- (8) Do not put or attach anything on the display area to avoid leaving marks on.
- (9) Do not touch the display with bare hands. This will stain the display area and degrade insulation between terminals (some cosmetics are determinate to the polarizers).
- (10) As glass is fragile, it tends to become or chipped during handling especially on the edges. Please avoid dropping or jarring.

### **11.2 INSTALLING LCD MODULE**

Attend to the following items when installing the LCM.

- (1) Cover the surface with a transparent protective plate to protect the polarizer and LC cell.
- (2) When assembling the LCM into other equipment, the spacer to the bit between the LCM and the fitting plate should have enough height to avoid causing stress to the module surface, refer to the individual specifications for measurements. The measurement tolerance should be  $\pm 0.1$ mm.

### **11.3 ELECTRO-STATIC DISCHARGE CONTROL**

Since this module uses a CMOS LSI, the same careful attention should be paid for electrostatic discharge as for an ordinary CMOS IC.

- (1) Make certain that you are grounded when handling LCM.
- (2) Before removing LCM from its packing case or incorporating it into a set, be sure the module and your body have the same electric potential.
- (3) When soldering the terminal of LCM, make certain the AC power source for the soldering iron does not leak.
- (4) When using an electric screwdriver to attach LCM, the screwdriver should be of ground potentiality to minimize as much as possible any transmission of electromagnetic waves produced sparks coming from the commutator of the motor.
- (5) As far as possible, make the electric potential of your work clothes and that of the workbenches to the ground potential.
- (6) To reduce the generation of electro-static discharge, be careful that the air in the work is not too dried. A relative humidity of 50%-60% is recommended.

#### 11.4 PRECAUTIONS FOR OPERATION

- (1) Viewing angle varies with the change of liquid crystal driving voltage ( $V_o$ ). Adjust  $V_o$  to show the best contrast.
- (2) Driving the LCD in the voltage above the limit will shorten its lifetime.
- (3) Response time is greatly delayed at temperature below the operating temperature range. However, this does not mean the LCD will be out of the order. It will recover when it returns to the specified temperature range.
- (4) If the display area is pushed hard during operation, the display will become abnormal. However, it will return to normal if it is turned off and then on.
- (5) Condensation on terminals can cause an electrochemical reaction disrupting the terminal circuit. Therefore, this product must be used and stored within the specified condition of  $23\pm 5^{\circ}\text{C}$ ,  $45\pm 20\% \text{RH}$ .
- (6) When turning the power on, input each signal after the positive/negative voltage becomes stable.

#### 11.5 SAFETY

- (1) It is recommended to crush damaged or unnecessary LCDs into pieces and wash them off with solvents such as acetone and ethanol, which should later be burned.
- (2) If any liquid leaks out of a damaged glass cell and comes in contact with the hands, wash off thoroughly with soap and water.



## 12.REVISION HISTORY

Version	Revise record	Date
1.0	Original version	05-06-20
2.0	Change specification format	05-11-20
3.0	Change LCM drawing	06-08-04
4.0	Change module temperature from normal to wide temperature	09-12-05
4.01	Perfect the VER4.0spec, Commany internal modify.	13-08-01

## SAMPLE APPROVED REPORT

### (样品确认单)

SAMPLE MODEL NO. (样品型号)	JHB320240B
SAMPLE SERIES NUMBER NO. (样品序号)	
SAMPLE QUANTITY (样品数量)	
COLOR/TYPE (底色/类型)	STN/BLUE
VIEWING DIRECTION (视角)	6:00
DRIVING METHOD (驱动参数)	1/240Duty, 1/16Bias
LOGIC VOLTAGE (工作电压)	5.0V
LCD VOP (LCD 驱动电压)	25.0V
OPERATING TEMP. (操作温度) °C	-20--70
STORAGE TEMP. (储存温度) °C	-30--80
POLARIZER----FRONT (首偏光片)	
POLARIZER----BACK (后偏光片)	Transmissive
CONTROLLER/DRIVER IC(控制/驱动 IC)	RA8835/SED1335/EQUIV
BACKLIGHT COLOR/TYPE (背光源类型/颜色)	LED/WHITE
DRAWING REV/NO./QUANTITY (图纸版本/数量)	
SPECIFICATION (规格书 份数)	
REMARKS: (备注)	
WRIT BY: _____ DATE: _____ APROV BY: _____ DATE: _____	
CUSTOMER'S APPROVAL (客户确认):	
1) FUNCTION (功能): <input type="checkbox"/> OK <input type="checkbox"/> N.G.	
2) DRIVER CONDITION (驱动条件): <input type="checkbox"/> OK <input type="checkbox"/> N.G.	
3) DISPLAY MODE (显示模式): <input type="checkbox"/> OK <input type="checkbox"/> N.G.	
4) VIEWING ANGLE (视角): <input type="checkbox"/> OK <input type="checkbox"/> N.G.	
5) BACKLIGHT (背光源): <input type="checkbox"/> OK <input type="checkbox"/> N.G.	
6) DISPLAYING PATTERN (显示效果): <input type="checkbox"/> OK <input type="checkbox"/> N.G.	
CUSTOMER'S CONCLUSIONS (客户意见): _____	
_____	
_____	
CUSTOMER'S SIGNATURE (客户签名): _____ DATE (日期): _____	