

CASE: NYLON 6/6, BLACK  
 FRAME/BACKET: STEEL, TIN OVER NICKEL  
 ACTUATOR BUTTON: PBT OR NYLON 6/6 (SEE TABLE), UL94HB, COLOR SEE TABLE  
 MOVING CONTACT: COPPER ALLOY, SILVER PLATE  
 FIXED CONTACT/TERMINALS: COPPER ALLOY, SILVER OVER NICKEL PLATE

ELECTRICAL:  
 MAX CONTACT RATING: 50MILLIAMPS@24V DC  
 MIN CONTACT RATING: 10MICROAMPS@1V DC  
 INITIAL CONTACT RESISTANCE: 100 MILLIOHMS MAX  
 INSULATION RESISTANCE: 100 MEGOHMS @ 100 VDC MIN.  
 DIELECTRIC STRENGTH: 500 VAC 50/60 Hz FOR 1 MINUTE  
 LIFE EXPECTANCY: 100,000 CYCLES

MECHANICAL:  
 ACTUATION FORCE: SEE TABLE  
 ACTUATION TRAVEL: 0.25±0.10[.010±.004]

ENVIRONMENTAL:  
 OPERATING TEMPERATURE: -35°C TO +85°C  
 STORAGE TEMPERATURE: -35°C TO +85°C  
 SOLDER HEAT RESISTANCE PER 109-202, CONDITION B  
 SOLDERABILITY PER EIA-364-52 CLASS II, CATEGORY 1

1 ALL MATERIALS AND FINISHES SHALL COMPLY WITH EH DIRECTIVE 2002/95/EC OF 27 JAN 2003 (ROHS)

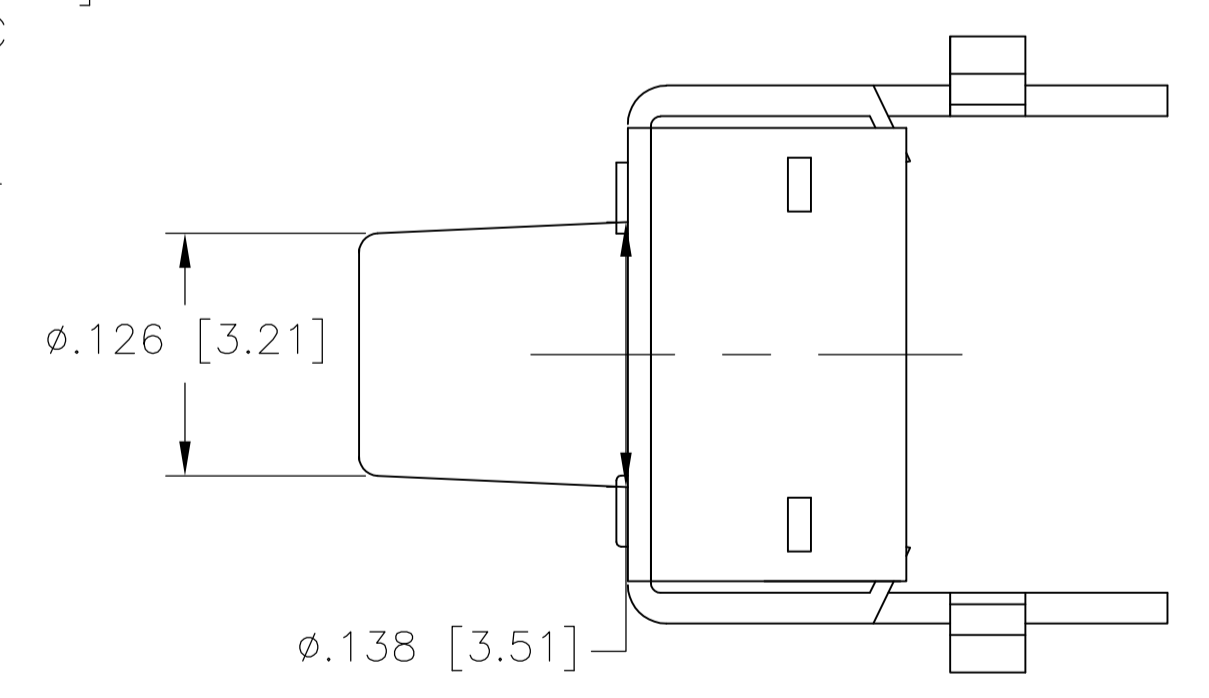
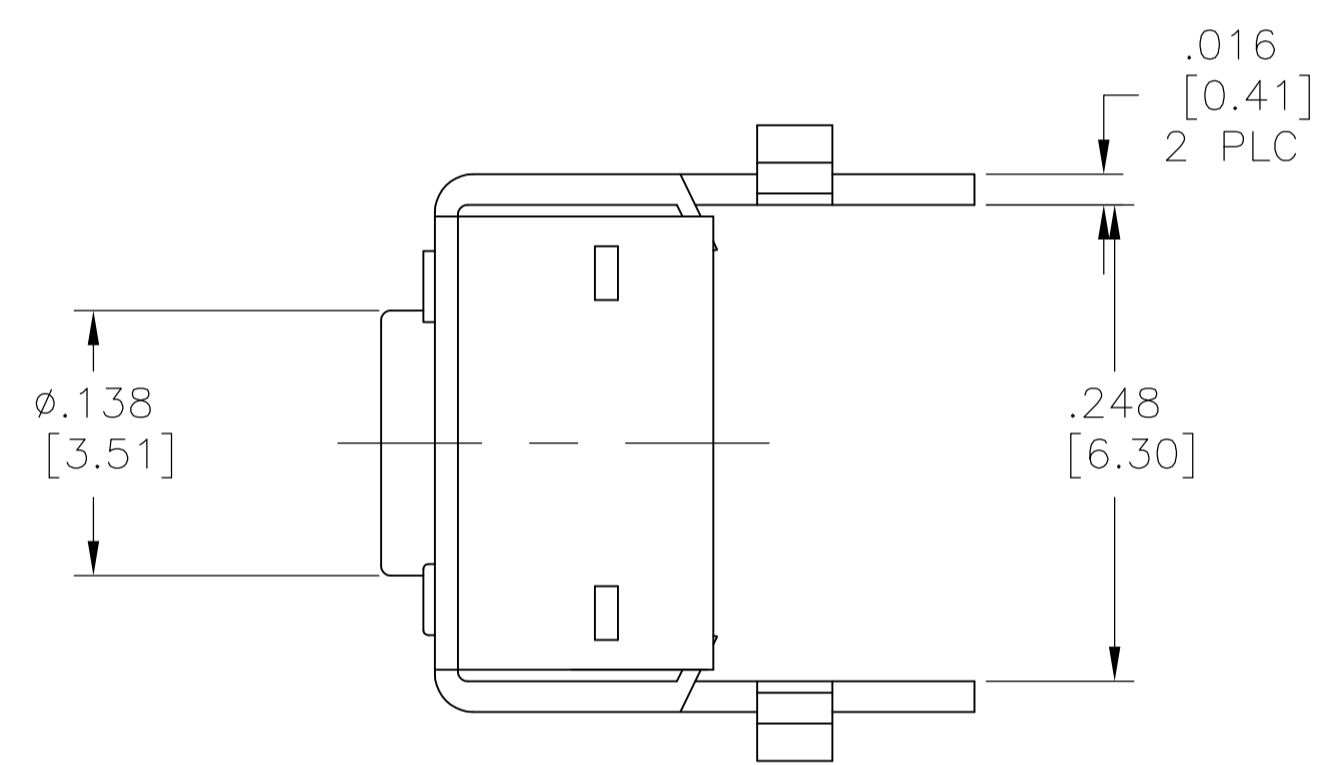
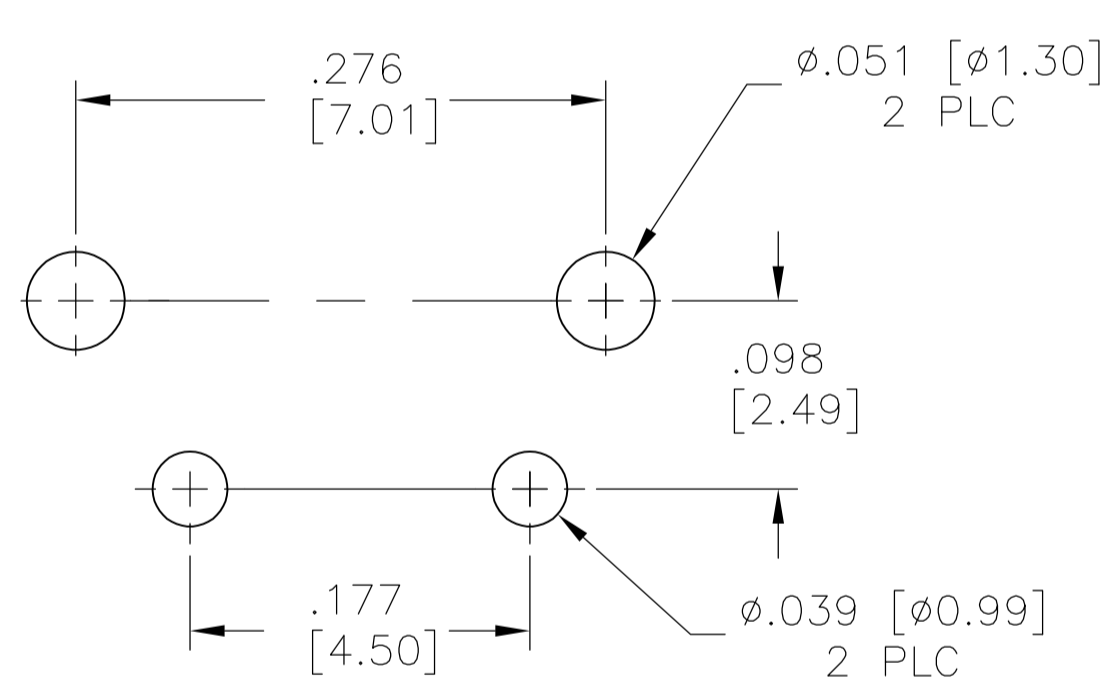

FSMRA5J

RECOMMENDED HOLE LAYOUT  
 TOLERANCE ±.002 UNLESS  
 OTHERWISE NOTED

CIRCUIT CHARACTERISTICS	
CONTACT POSITION	CIRCUIT DIAGRAM
OFF	
(ON) 1-2	

	ACTUATOR MATL	ACTUATOR COLOR	ACTUATION FORCE	DIM L	DIM A	ALCO PIN	TE PIN
	NYLON 6/6	RED	260 +/-50 GF	.624 (15.85)	.522 (13.25)	FSMRA8JHA	2-1825027-4
OBSOLETE	NYLON 6/6	BLACK	160 +/-50 GF	.624 (15.85)	.522 (13.25)	FSMRA8JH	2-1825027-3
OBSOLETE	NYLON 6/6	BROWN	100 +/-30 GF	.624 (15.85)	.522 (13.25)	FSMRA8JHL	2-1825027-2
OBSOLETE	NYLON 6/6	RED	260 +/-50 GF	.467 (11.85)	.364 (9.24)	FSMRA7JHA	2-1825027-1
	NYLON 6/6	BLACK	160 +/-50 GF	.467 (11.85)	.364 (9.24)	FSMRA7JH	2-1825027-0
OBSOLETE	NYLON 6/6	BROWN	100 +/-30 GF	.467 (11.85)	.364 (9.24)	FSMRA7JHL	1-1825027-9
OBSOLETE	NYLON 6/6	RED	260 +/-50 GF	.270 (6.85)	.167 (4.24)	FSMRA6JHA	1-1825027-8
	NYLON 6/6	WHITE	160 +/-50 GF	.270 (6.85)	.167 (4.24)	FSMRA6JH	1-1825027-7
OBSOLETE	NYLON 6/6	BROWN	100 +/-30 GF	.270 (6.85)	.167 (4.24)	FSMRA6JHL	1-1825027-6
OBSOLETE	NYLON 6/6	RED	260 +/-50 GF	.242 (6.15)	.140 (3.55)	FSMRA5JHA	1-1825027-5
	NYLON 6/6	IVORY	160 +/-50 GF	.242 (6.15)	.140 (3.55)	FSMRA5JH	1-1825027-4
OBSOLETE	NYLON 6/6	BROWN	100 +/-30 GF	.242 (6.15)	.140 (3.55)	FSMRA5JHL	1-1825027-3
	PBT	RED	260 +/-50 GF	.329 (8.35)	.226 (5.74)	FSMRA4JHA	1-1825027-2
	PBT	BLACK	160 +/-50 GF	.329 (8.35)	.226 (5.74)	FSMRA4JH	1-1825027-1
OBSOLETE	PBT	BROWN	100 +/-30 GF	.329 (8.35)	.226 (5.74)	FSMRA4JHL	1-1825027-0
OBSOLETE	NYLON 6/6	RED	260 +/-50 GF	.230 (5.85)	.128 (3.25)	FSMRA3JHA	1825027-9
	NYLON 6/6	BLUE	160 +/-50 GF	.230 (5.85)	.128 (3.25)	FSMRA3JH	1825027-8
OBSOLETE	NYLON 6/6	BROWN	100 +/-30 GF	.230 (5.85)	.128 (3.25)	FSMRA3JHL	1825027-7
	PBT	RED	260 +/-50 GF	.152 (3.86)	.049 (1.24)	FSMRA2JHA	1825027-6
	PBT	BLACK	160 +/-50 GF	.152 (3.86)	.049 (1.24)	FSMRA2JH	1825027-5
	PBT	BROWN	100 +/-30 GF	.152 (3.86)	.049 (1.24)	FSMRA2JHL	1825027-4
	PBT	RED	260 +/-50 GF	.124 (3.15)	.022 (0.56)	FSMRA1JHA	1825027-3
	PBT	BLACK	160 +/-50 GF	.124 (3.15)	.022 (0.56)	FSMRA1JH	1825027-2
	PBT	BROWN	100 +/-30 GF	.124 (3.15)	.022 (0.56)	FSMRA1JHL	1825027-1

THIS DRAWING IS A CONTROLLED DOCUMENT.

DIMENSIONS: INCHES [mm]	TOLERANCES UNLESS OTHERWISE SPECIFIED:	DIN M. BINNER 260CT04	Tyco Electronics Corporation Harrisburg, PA 17105-3608
0 PLC ± -	1 PLC ± -	M. SARVER 260CT04	
2 PLC ± -	3 PLC ± -	M. SARVER 260CT04	NAME
4 PLC ± -	ANGLES ± -		PRODUCT SPEC
			APPLICATION SPEC
MATERIAL	FINISH	WEIGHT	SIZE CASE CODE DRAWING NO
			A1 00779 1825027
		CUSTOMER DRAWING	RESTRICTED TO
		SCALE 10:1	SHEET 1 OF 1 REV G2