

## 2A Low Dropout Regulator with Enable

### Features

- Adjustable Output from 1.2V to 4.8V Using External Resistors
- 1.5V, 1.8V and 2.5V options by Setting ADJ Pin Below 0.2V
- Fixed 2.5V, 3.3V and 5V Output for TO-252
- Over current and over temperature protection
- 500mV dropout @2A
- Enable pin
- 10µA quiescent current in shutdown
- Output recovery mode in OTP
- Connect ADJ to GND for fixed output mode
- TO-252 and TO-252-5 Package

### General Description

The G962 is a high performance positive voltage regulator designed for use in applications requiring very low dropout voltage at up to 2 Amps. Since it has superior dropout characteristics compared to regular LDOs, it can be used to supply 2.5V on motherboards or 1.5V, 1.8V on peripheral cards from the 3.3V supply thus allowing the elimination of costly heatsinks. An enable pin further reduces power dissipation while shut down. The G962 provides excellent regulation over variations in line, load and temperature.

The G962 is available with 1.5V, 1.8V, 2.5V, 3.3V and 5V internally preset outputs.

### Applications

- Battery powered systems
- Motherboards
- Peripheral cards
- Set Top Boxes
- Notebook Computers

### Ordering Information

ORDER NUMBER (Pb free/Green)	MARKING	TEMP. RANGE	PACKAGE
G962-25T45Uf	G962-25	-40°C ~ +85°C	TO-252
G962-33T45Uf	G962-33	-40°C ~ +85°C	TO-252
G962-50T45Uf	G962-50	-40°C ~ +85°C	TO-252
G962-25T45D	G962-25	-40°C ~ +85°C	TO-252
G962-33T45D	G962-33	-40°C ~ +85°C	TO-252
G962-50T45D	G962-50	-40°C ~ +85°C	TO-252
G962-15ADJTJUf	G962-15	-40°C ~ +85°C	TO-252-5
G962-18ADJTJUf	G962-18	-40°C ~ +85°C	TO-252-5
G962-25ADJTJUf	G962-25	-40°C ~ +85°C	TO-252-5

Note: T4: TO-252      TJ:TO-252-5

U & D : Tape & Reel

e.g. 18 denotes the 1.8V output voltage.

### Pin Configuration

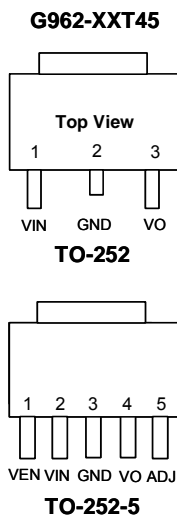

### Typical Application Circuit

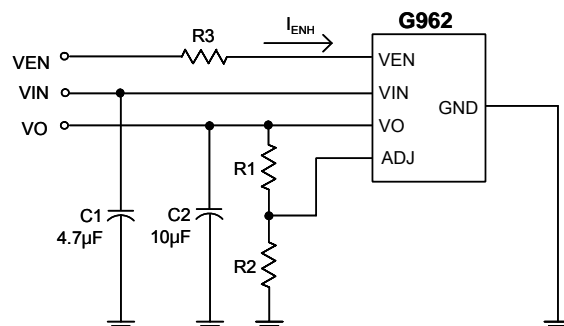

$$VO = \frac{1.2 (R1+R2)}{R2} \text{ Volts}$$

R2=12kΩ is recommended

R3 should be connected for current I<sub>ENH</sub> restriction as V<sub>EN</sub> > V<sub>IN</sub>+0.3V