

RoHS Compliant Product
A suffix of "-C" specifies halogen & lead-free

FEATURES

The 2SBA92 is designed for applications as a video output to drive color CRT, or as a dialer circuit in electronics telephone.

MARKING

A92

PACKAGE INFORMATION

Package	MPQ	Leader Size
SOT-89	1K	13' inch

SOT-89

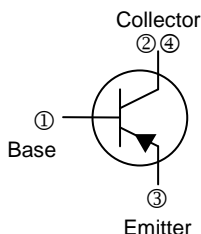
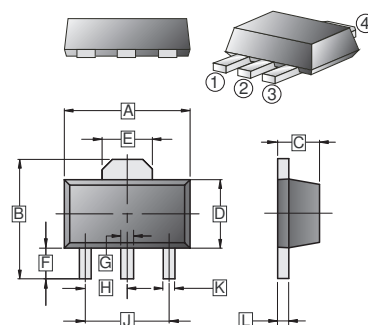

REF.	Millimeter		REF.	Millimeter	
	Min.	Max.		Min.	Max.
A	4.40	4.60	G	0.40	0.58
B	3.94	4.25	H	1.50	TYP
C	1.40	1.60	J	3.00	TYP
D	2.30	2.60	K	0.32	0.52
E	1.50	1.70	L	0.35	0.44
F	0.89	1.20			

ABSOLUTE MAXIMUM RATINGS ($T_A = 25^\circ\text{C}$ unless otherwise specified)

Parameter	Symbol	Rating	Unit
Collector-Base Voltage	V_{CBO}	-310	V
Collector-Emitter Voltage	V_{CEO}	-305	V
Emitter-Base Voltage	V_{EBO}	-5	V
Collector Current -Continuous	I_C	-0.2	A
Collector Current -Pulsed	I_{CM}	-0.5	A
Collector Power Dissipation	P_D	0.5	W
Thermal Resistance from Junction to Ambient	$R_{\theta JA}$	250	$^\circ\text{C} / \text{W}$
Junction & Storage Temperature	T_J, T_{STG}	150, -55~150	$^\circ\text{C}$

ELECTRICAL CHARACTERISTICS ($T_A = 25^\circ\text{C}$ unless otherwise specified)

Parameter	Symbol	Min.	Typ.	Max.	Unit	Test Conditions
Collector-base breakdown voltage	$V_{(BR)CBO}$	-310	-	-	V	$I_C = -100\mu\text{A}, I_E = 0$
Collector-emitter breakdown voltage	$V_{(BR)CEO}$	-305	-	-	V	$I_C = -1\text{mA}, I_B = 0$
Emitter-base breakdown voltage	$V_{(BR)EBO}$	-5	-	-	V	$I_E = -100\mu\text{A}, I_C = 0$
Collector cut-off current	I_{CBO}	-	-	-0.25	μA	$V_{CB} = -200\text{V}, I_E = 0$
Collector cut-off current	I_{CEO}	-	-	-0.25	μA	$V_{CE} = -200\text{V}, I_B = 0$
		-	-	-5		$V_{CE} = -300\text{V}, I_B = 0$
Emitter cut-off current	I_{EBO}	-	-	-0.1	μA	$V_{EB} = -5\text{V}, I_C = 0$
DC current gain	$h_{FE(1)}$	60	-	-		$V_{CE} = -10\text{V}, I_C = -1\text{mA}$
	$h_{FE(2)}$	100	-	300		$V_{CE} = -10\text{V}, I_C = -10\text{mA}$
	$h_{FE(3)}$	60	-	-		$V_{CE} = -10\text{V}, I_C = -80\text{mA}$
Collector-emitter saturation voltage	$V_{CE(sat)}$	-	-	-0.2	V	$I_C = -20\text{mA}, I_B = -2\text{mA}$
Base-emitter saturation voltage	$V_{BE(sat)}$	-	-	-0.9	V	$I_C = -20\text{mA}, I_B = -2\text{mA}$
Transition frequency	f_T	50	-	-	MHz	$V_{CE} = -20\text{V}, I_C = -10\text{mA}, f = 30\text{MHz}$