

PCB LAYOUT

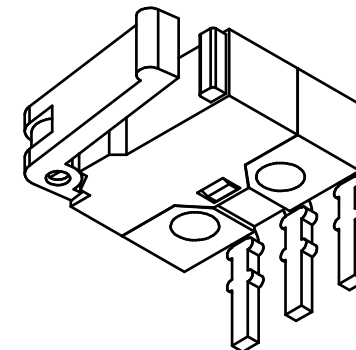

O.P. (MM)	P.T. (MM)
6.7 ±0.5	1.8 Max.

O.P. = OPERATING POINT
P.T. = PRE-TRAVEL

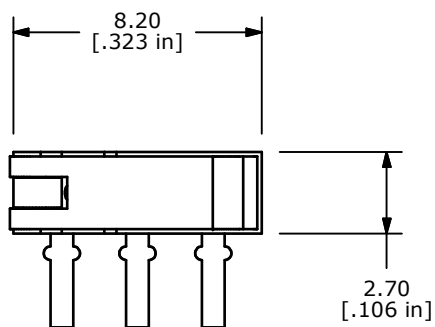
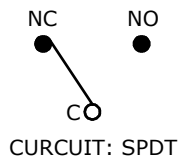
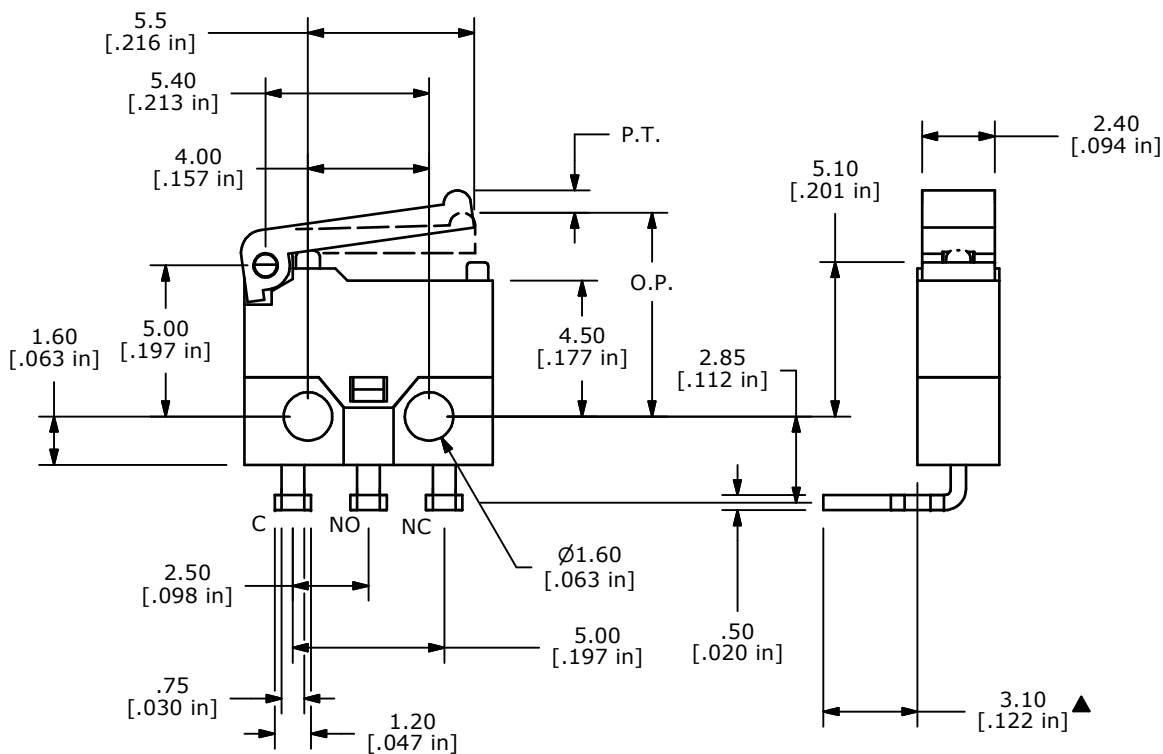

NOTES:

1. ALL DIMENSIONS IN MM [INCH]
2. GENERAL TOLERANCE: X.X±0.4
X.XX±0.25
3. RATING: 0.3A @ 6VDC
- ▲ 4. OPERATING FORCE: 20 ± 10gf
5. OPERATING TEMP: -25°C TO 85°C
6. ELECTRICAL LIFE: 50,000 CYCLES MIN.
7. INSULATION RESISTANCE: 100 MEGA-OHMS MIN.
8. DIELECTRIC STRENGTH: 250VAC 1 MINUTE (INITIAL VALUE)
9. CONTACT RESISTANCE: 50 MILLI -OHMS MAX.
10. ▲ DENOTES CRITICAL PARAMETER.
11. 2002/95/EC (ROHS) COMPLIANT

REV	PCR NO	DESCRIPTION	DATE	BY
D	18561	BODY CHANGED TO ADD STOP	6/18/09	BLR
C	18269	TITLE CHANGE FROM TS0101F030V3	10/6/08	BLR
B	17974	CHANGE OPERATING FORCE SPEC	2/15/08	BLR
A	17918	New Product Release	1/8/08	rc

THE INFORMATION CONTAINED IN THIS DOCUMENT IS PROPRIETARY TO E-SWITCH AND IS NOT TO BE COPIED OR TRANSFERRED



TITLE TS0101F020V3

SCALE	DATE	DR	DWG	REV
4=1	6/18/2009	BLR	Q980001	D