

SPIDER - TLE7232GS

SPI Driver for Enhanced Relay Control

Automotive Power



Never stop thinking

Table of Contents

1	Product Summary	3
2	Block Diagram	5
2.1	Terms	6
3	Pin Configuration	7
3.1	Pin Assignment	7
3.2	Pin Definitions and Functions	7
4	General Product Characteristics	9
4.1	Absolute Maximum Ratings	9
4.2	Thermal Resistance	10
5	Block Description and Electrical Characteristics	11
5.1	Power Stages	11
5.1.1	Power Supply	11
5.1.2	Input Circuit	12
5.1.3	Inductive Output Clamp	13
5.1.4	Timing Diagrams	13
5.1.5	Electrical Characteristics	14
5.1.6	Command Description	16
5.2	Protection Functions	17
5.2.1	Overload Protection	18
5.2.2	Overtemperature Protection	18
5.2.3	Reverse Polarity Protection	18
5.2.4	Electrical Characteristics	19
5.2.5	Command Description	19
5.3	Diagnostic Features	20
5.3.1	Diagnosis Timing	21
5.3.1.1	Open Load Behavior	21
5.3.1.2	Short to Ground Behavior	21
5.3.2	Electrical Characteristics	22
5.3.3	Command Description	22
5.4	Serial Peripheral Interface (SPI)	23
5.4.1	SPI Signal Description	23
5.4.2	Daisy Chain Capability	24
5.4.3	Timing Diagrams	25
5.4.4	Electrical Characteristics	25
5.4.5	SPI Protocol	27
5.4.6	Register Overview	28
6	Application Circuit	29
7	Package Outlines	30
8	Revision History	31

SPI Driver for Enhanced Relay Control Eight Channel Low-Side Switch

SPIDER - TLE7232GS



1 Product Summary

Features

- 16 bit SPI for diagnostics and control
- SPI providing daisy chain capability
- 3.3 V and 5 V compatible SPI
- 3 input pins offers complete flexibility for PWM operation
- Stable behavior at undervoltage
- Green Product (RoHS compliant)
- AEC Qualified

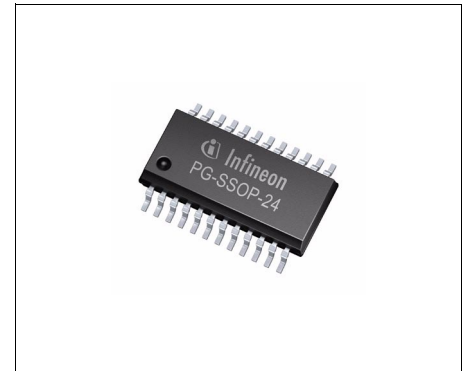

PG-SSOP-24-6

Table 1 Product Summary

Supply voltage	V_{DD}	4.5 ... 5.5 V
Supply voltage for SO buffer	V_{VSO}	3.0 ... 5.5 V
On-State Resistance at 150 °C	$R_{DS(ON, max)}$	2.1 Ω
Nominal load current	$I_{L(nom, min)}$	240 mA
Overload current limitation	$I_{DS(LIM, min)}$	1 A
Power supply reset current (quiescent current)	$I_{DD(RST, max)}$	5 μ A
Output leakage current per channel at 25 °C	$I_{DS(OFF, max)}$	1 μ A
Drain to source clamping voltage	$V_{DS(CL, min)}$	48 V
SPI clock frequency	$f_{SCLK(max)}$	5 MHz

Type	Package	Marking
SPIDER - TLE7232GS	PG-SSOP-24-6	TLE7232GS

Protective Functions

- Short circuit protection
- Overload protection, configurable behavior (limitation or shutdown)
- Thermal shutdown, configurable behavior (latch or restart)
- Electrostatic discharge protection (ESD)

Diagnostic Functions

- Diagnostic information via SPI
- Open load detection in OFF-state
- Shorted to GND detection in OFF-state
- Overtemperature in ON-state
- Overload in ON-state

Applications

- Especially designed for driving relays in automotive applications
- All types of capacitive, resistive and inductive loads

Description

The SPIDER - TLE7232GS is an eight channel low-side relay switch (typ. 1.0Ω per channel) in PG-SSOP-24-6 package providing embedded protective functions. The 16 bit serial peripheral interface (SPI) is utilized for control and diagnosis of the device and the loads. The SPI interface provides daisy-chain capability in order to assemble multiple devices in one SPI chain by using the same number of micro-controller pins.

The SPIDER - TLE7232GS is equipped with three input pins that can be individually routed to the output control of some channels (please refer to [Section 5.1.2](#) for details) thus offering complete flexibility in design and PCB-layout. The input mapping as well as the boolean operation between input signal and output control signal is configured via SPI.

The device provides full diagnosis of the load, which is open load, short to GND as well as short circuit to V_{bat} detection and overload / overtemperature indication. The SPI diagnosis flags indicate latched fault conditions that may have occurred.

Each output stage is protected against short circuit. In case of overload, the current of the affected channel is limited. There is a temperature sensor available for each channel to protect the device in case of overtemperature. The shut down behavior in case of overload or overtemperature can be configured via SPI for each channel individually.

2 Block Diagram

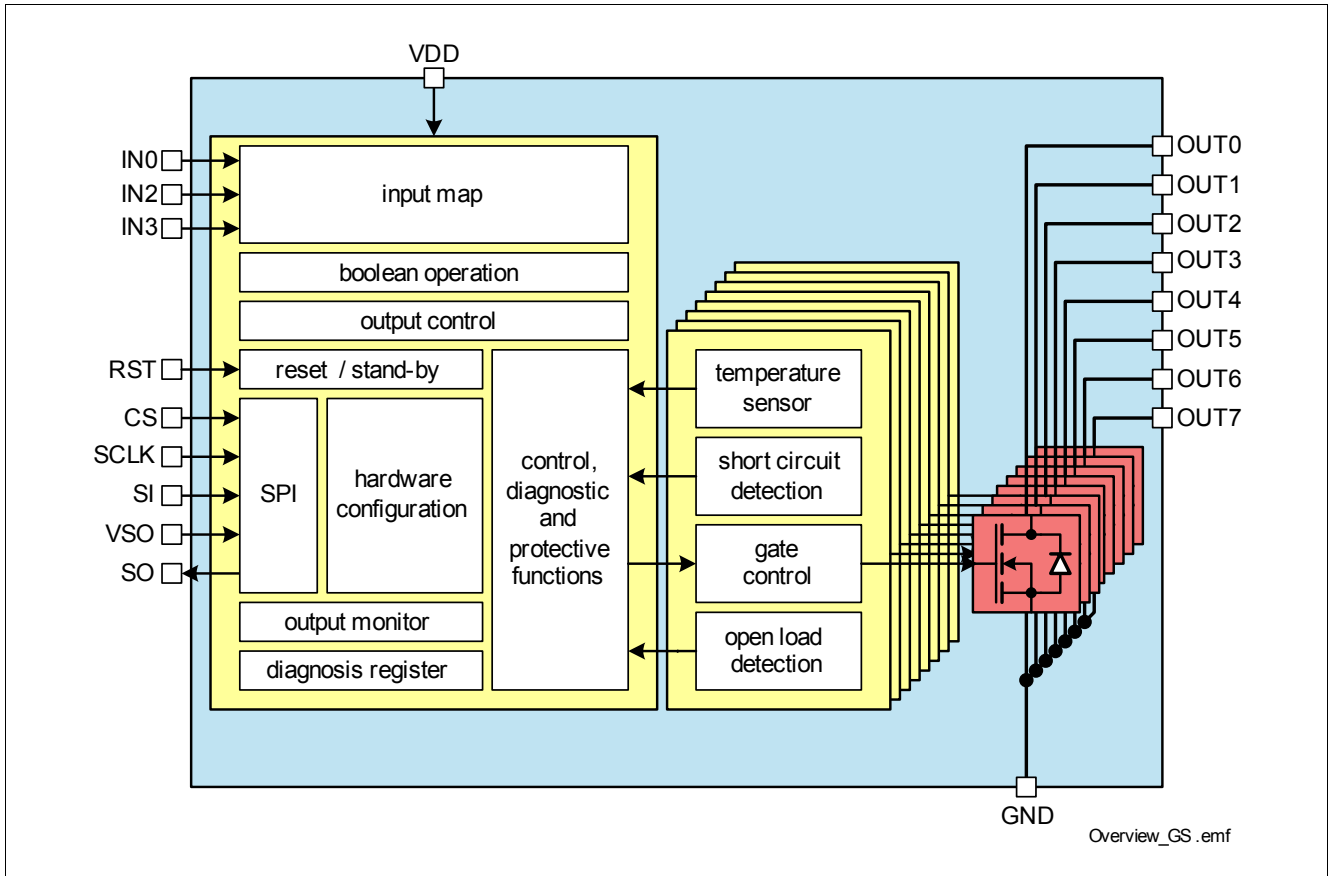

Figure 1 Block Diagram

2.1 Terms

Following figure shows all terms used in this data sheet.

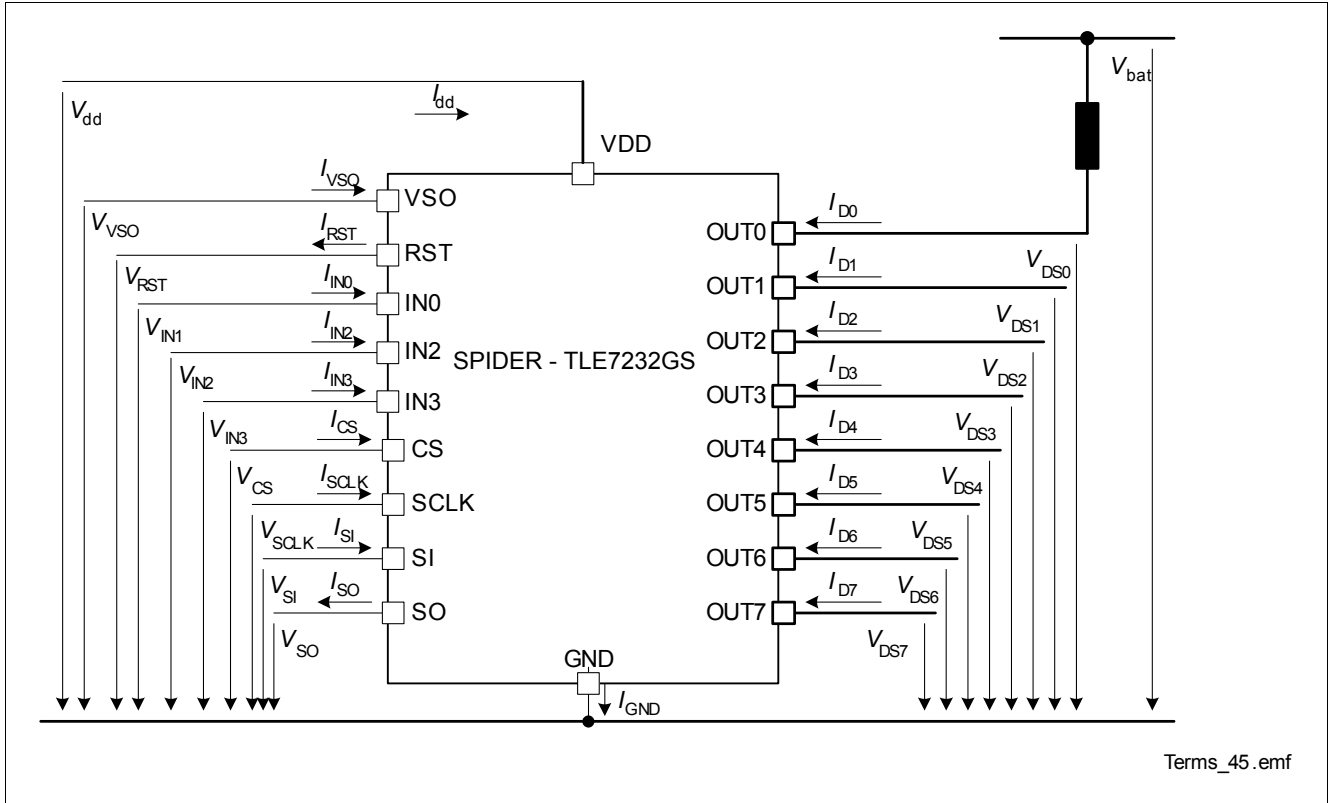

Figure 2 Terms

In all tables of electrical characteristics is valid: Channel related symbols without channel number are valid for each channel separately (e.g. V_{DS} specification is valid for $V_{DS0} \dots V_{DS7}$).

All SPI register bits are marked as follows: ADDR.PARAMETER (e.g. CTL.OUT0). In SPI register description, the values in bold letters (e.g. **0**) are default values.

3 Pin Configuration

3.1 Pin Assignment

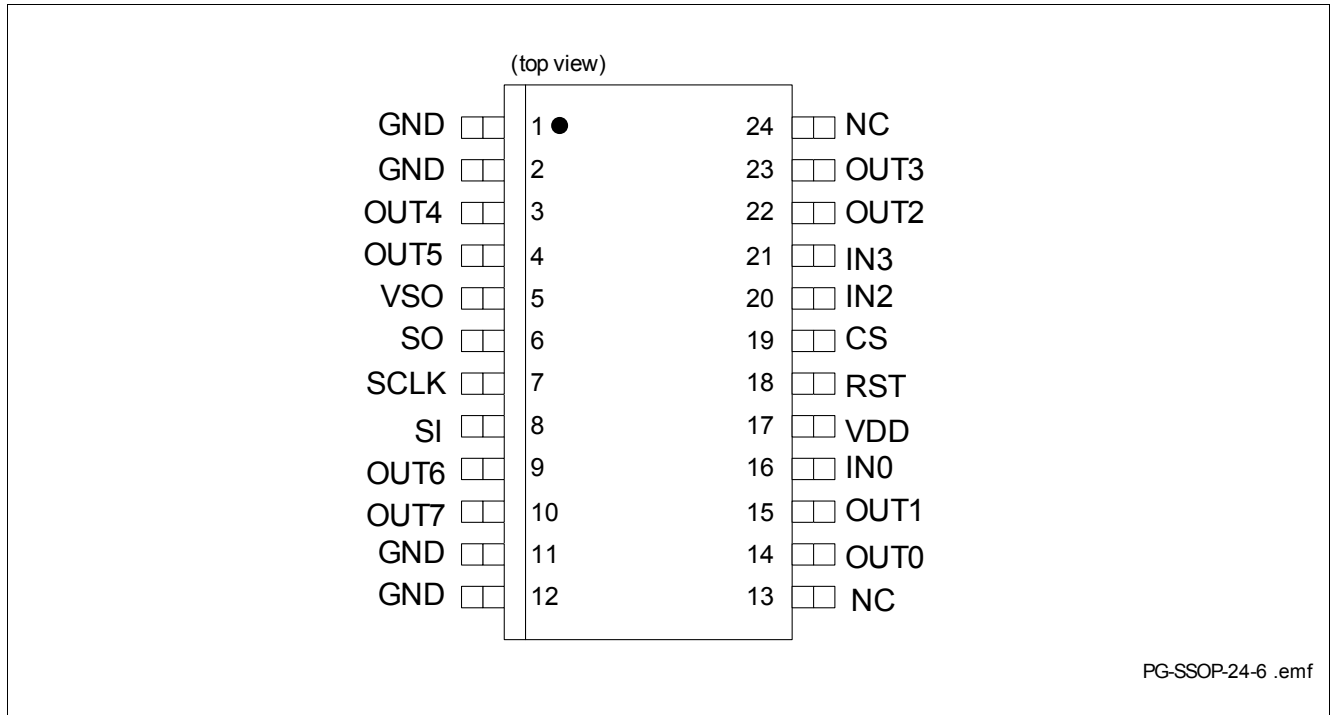

Figure 3 Pin Configuration

3.2 Pin Definitions and Functions

Pin	Symbol	I/O	Function
Power Supply			
17	V_{DD}	–	Power Supply
5	V_{SO}	–	Power Supply for SO buffer
1, 2, 11, 12	GND	–	Ground
Power Stages			
14	OUT0	O	Drain of power transistor channel 0
15	OUT1	O	Drain of power transistor channel 1
22	OUT2	O	Drain of power transistor channel 2
23	OUT3	O	Drain of power transistor channel 3
3	OUT4	O	Drain of power transistor channel 4
4	OUT5	O	Drain of power transistor channel 5
9	OUT6	O	Drain of power transistor channel 6
10	OUT7	O	Drain of power transistor channel 7

Pin	Symbol	I/O	Function
Inputs			
18	RST	I	Reset Input Pin (active low)
16	IN0	I	Input Multiplexer Input Pin for output Out0
20	IN2	I	Input Multiplexer Input Pin for output Out2
21	IN3	I	Mappable Input Pin for all outputs, default Out3
SPI			
19	CS	I	SPI Chip Select (active low)
7	SCLK	I	Serial Clock
8	SI	I	Serial Data In
6	SO	O	Serial Data Out
Not Used			
13, 24	NC	–	Not connected

4 General Product Characteristics

4.1 Absolute Maximum Ratings

Absolute Maximum Ratings ¹⁾

$T_j = -40\text{ °C}$ to 150 °C ; $V_{DD} = 4.5\text{ V}$ to 5.5 V ; all voltages with respect to ground, positive current flowing into pin (unless otherwise specified)

Pos.	Parameter	Symbol	Limit Values		Unit	Conditions
			Min.	Max.		
Power Supply						
4.1.1	Power supply voltage	V_{DD}	-0.3	5.5	V	–
4.1.2	V_{SO} supply voltage	V_{VSO}	-0.3	$V_{DD} + 0.3$	V	²⁾
4.1.3	Power supply voltage for full short circuit protection (single pulse)	$V_{bat(SC)}$	0 –	20 28	V	$OVL = 0$ ³⁾ $OVL = 1$

Power Stages

4.1.4	Load current	I_D	-1	1	A	–
4.1.5	Voltage at power transistor	V_{DS}	–	48	V	–
4.1.6	Maximum energy dissipation one channel single pulse	E_{AS}	–	65	mJ	⁴⁾ $T_{j(0)} = 85\text{ °C}$ $I_{D(0)} = 0.35\text{ A}$ $T_{j(0)} = 150\text{ °C}$ $I_{D(0)} = 0.25\text{ A}$
	–		30			
4.1.6	Maximum energy dissipation one channel repetitive pulses	E_{AR}	–	–	mJ	⁴⁾ $T_{j(0)} = 150\text{ °C}$ $I_{D(0)} = 0.20\text{ A}$ $I_{D(0)} = 0.17\text{ A}$
	$1 \cdot 10^4$ cycles		–	18		
	$1 \cdot 10^6$ cycles		–	13		

Logic Pins

4.1.7	Voltage at input pins	V_{IN}	-0.3	5.5	V	–
4.1.8	Voltage at reset pin	V_{RST}	-0.3	5.5	V	–
4.1.9	Voltage at chip select pin	V_{CS}	-0.3	5.5	V	–
4.1.10	Voltage at serial clock pin	V_{SCLK}	-0.3	5.5	V	–
4.1.11	Voltage at serial input pin	V_{SI}	-0.3	5.5	V	–
4.1.12	Voltage at serial output pin	V_{SO}	-0.3	5.5	V	–

Temperatures

4.1.13	Junction Temperature	T_j	-40	150	°C	–
4.1.14	Dynamic temperature increase while switching	ΔT_j	–	60	°C	–
4.1.15	Storage Temperature	T_{stg}	-55	150	°C	–

Absolute Maximum Ratings (cont'd)¹⁾

$T_j = -40\text{ °C to }150\text{ °C}$; $V_{DD} = 4.5\text{ V to }5.5\text{ V}$; all voltages with respect to ground, positive current flowing into pin (unless otherwise specified)

Pos.	Parameter	Symbol	Limit Values		Unit	Conditions
			Min.	Max.		

ESD Susceptibility

4.1.16	ESD capability of all pins versus GND	V_{ESD}	-2	2	kV	HBM ⁵⁾
--------	---------------------------------------	-----------	----	---	----	-------------------

1) Not subject to production test, specified by design.

2) $V_{DD} + 0.3\text{ V} < 5.5\text{ V}$

3) Details on configuration of protective function OLCR.OVL can be found in [Section 5.2.5](#)

4) Pulse shape represents inductive switch off: $I_D(t) = I_D(0) \times (1 - t / t_{\text{pulse}})$; $0 < t < t_{\text{pulse}}$

5) ESD susceptibility, HBM according to EIA/JESD 22-A114B

Note: Stresses above the ones listed here may cause permanent damage to the device. Exposure to absolute maximum rating conditions for extended periods may affect device reliability.

Note: Integrated protection functions are designed to prevent IC destruction under fault conditions described in the data sheet. Fault conditions are considered as "outside" normal operating range. Protection functions are not designed for continuous repetitive operation.

4.2 Thermal Resistance

Note: This thermal data was generated in accordance with JEDEC JESD51 standards. For more information, go to www.jedec.org.

Pos.	Parameter	Symbol	Limit Values			Unit	Conditions
			Min.	Typ.	Max.		
4.2.17	Junction to Solder Point	R_{thJSP}	–	–	25	K/W	pin 1, 2, 11, 12 ¹⁾
4.2.18	Junction to Ambient (1s0p+600mm ² Cu)	R_{thJA}	–	64	–	K/W	¹⁾²⁾
4.2.19	Junction to Ambient (2s2p)	R_{thJA}	–	55	–	K/W	¹⁾³⁾

1) Specified R_{thJSP} value is simulated at natural convection on a cold plate setup (all pins are fixed to ambient temperature). $T_a = 25\text{ °C}$. LS0 to LS7 are dissipating 1 W power (0.125 W each).

2) Specified R_{thJA} value is according to Jedec JESD51-2,-3 at natural convection on FR4 1s0p board; The product (Chip+Package) was simulated on a 76.2 x 114.3 x 1.5 mm board with additional heatspreading copper area of 600mm² and 70 μm thickness. $T_a = 25\text{ °C}$. LS0 to LS7 are dissipating 1 W power (0.125 W each).

3) Specified R_{thJA} value is according to Jedec JESD51-2,-7 at natural convection on FR4 2s2p board; The product (Chip+Package) was simulated on a 76.2 x 114.3 x 1.5 mm board with 2 inner copper layers (2 x 70 μm Cu, 2 x 35 μm Cu). $T_a = 25\text{ °C}$. LS0 to LS7 are dissipating 1 W power (0.125 W each).

5 Block Description and Electrical Characteristics

5.1 Power Stages

The SPIDER - TLE7232GS is an eight channel low-side relay switch. The power stages are built by N-channel vertical power MOSFET transistors.

5.1.1 Power Supply

The SPIDER - TLE7232GS is supplied by power supply line V_{DD} which is used for the digital as well as the analog functions of the device including the gate control of the power stages. There is a power-on reset function implemented for the supply line. After start-up of the power supply, all SPI registers are reset to their default values. A capacitor at pins V_{DD} to GND is recommended.

The pin V_{SO} is the supply pin of the digital output buffer at pin SO.

V_{SO} can therefore be used to vary the high state output voltage of the SO pin, in order to be compatible to 3.3 V and 5 V microcontrollers. If V_{SO} supply voltage is missing the device is fully functional, only the SO pin has no output.

There is a reset pin available. At low level at this pin, all registers are set to their default values and the quiescent supply current is minimized.

5.1.2 Input Circuit

There are three input pins available at SPIDER - TLE7232GS to control the output stages.

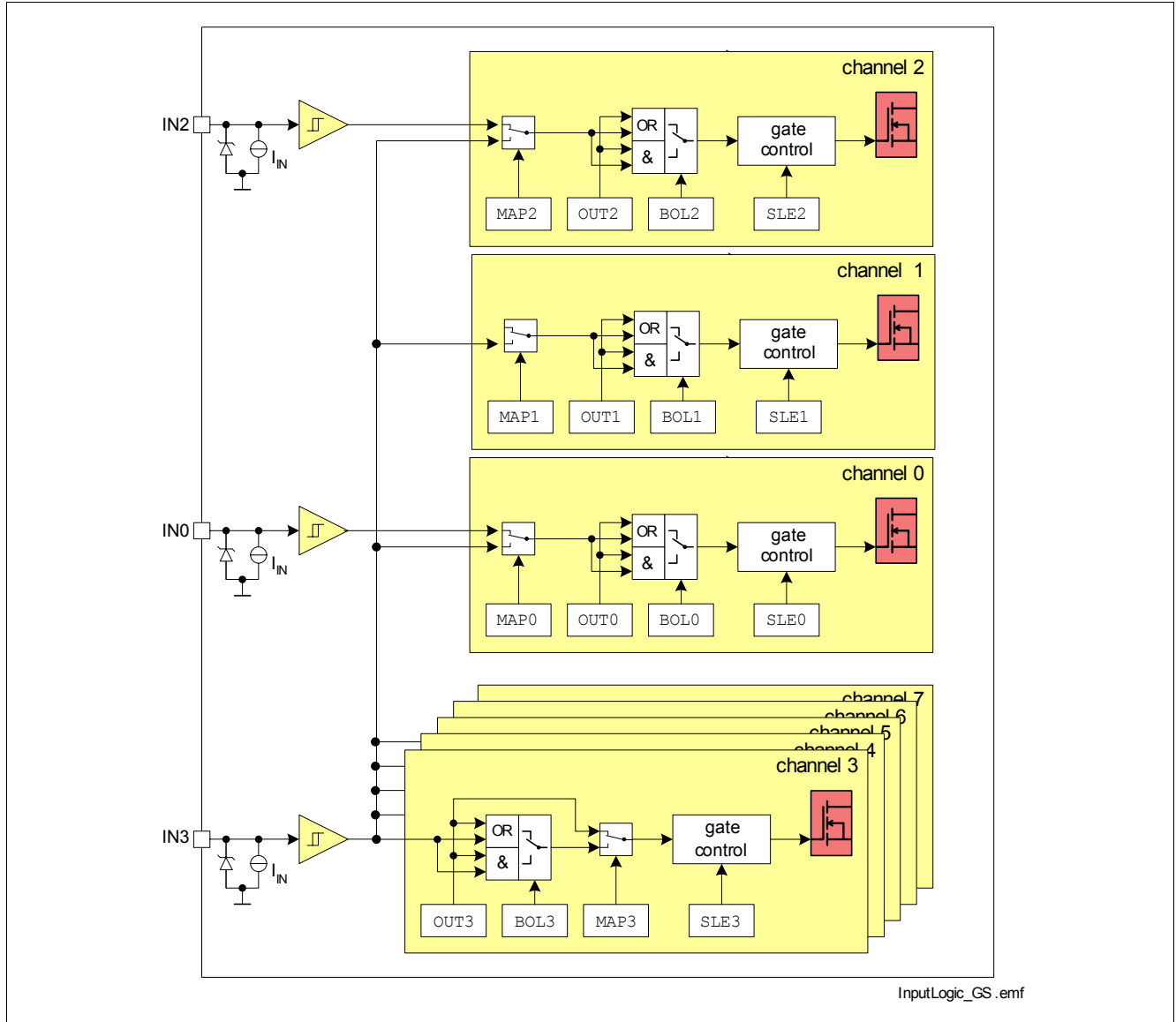

Figure 4 Input Mapping and Boolean Operator

The input signal of IN3 can be configured to be used as control signal of the output stages for each channel separately. The channels 0 to 2 differ from the channels 3 to 7 in the mapping behavior.

IN0 is a direct input to channel Out0, while IN2 is a direct input to Out2.

OUT0 can be switched with the SPI Flag MAP0 to the mappable input IN3, default is IN0.

OUT2 can be switched with the SPI Flag MAP2 to the mappable input IN3, default is IN2.

OUT3 is controlled by default with IN3, but IN3 can be programmed to each channel.

Therefore after power up the inputs are always mapped to their corresponding outputs.

Please refer to [Figure 4](#) for details.

The current sink to ground at the input pins ensures that the channels switch off in case of open pin. The zener diode protects the input circuit against ESD pulses.

5.1.3 Inductive Output Clamp

When switching off inductive loads, the potential at pin OUT rises to $V_{DS(CL)}$ potential, because the inductance intends to continue driving the current. The voltage clamping is necessary to prevent destruction of the device, see [Figure 5](#) for details. Nevertheless, the maximum allowed load inductance is limited.

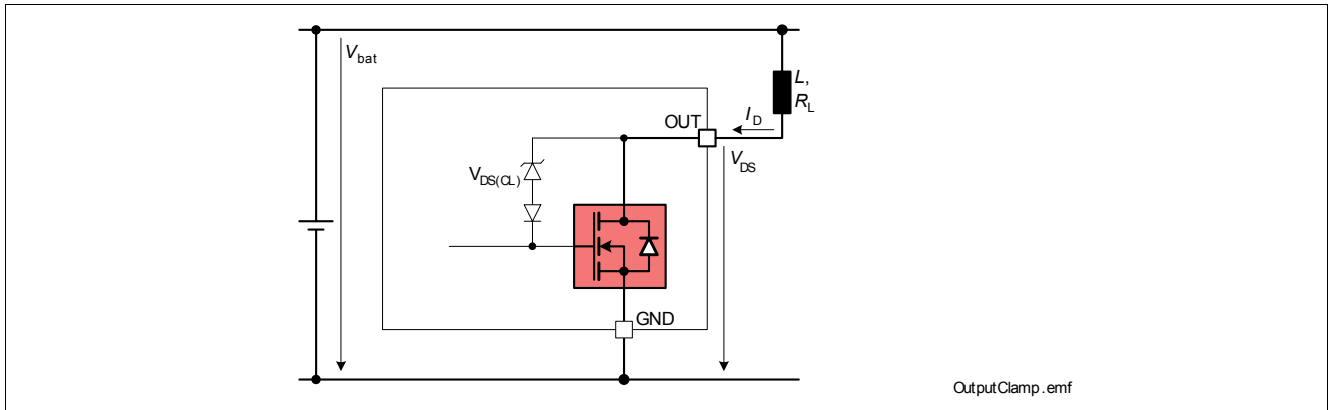

Figure 5 Output Clamp Implementation

Maximum Load Inductance

During demagnetization of inductive loads, energy has to be dissipated in the SPIDER - TLE7232GS. This energy can be calculated with following equation:

$$E = V_{DS(CL)} \cdot \left[\frac{V_{bat} - V_{DS(CL)}}{R_L} \cdot \ln\left(1 - \frac{R_L \cdot I_D}{V_{bat} - V_{DS(CL)}}\right) + I_D \right] \cdot \frac{L}{R_L} \quad (1)$$

The equation simplifies under the assumption of $R_L = 0$:

$$E = \frac{1}{2} L I_D^2 \cdot \left(1 - \frac{V_{bat}}{V_{bat} - V_{DS(CL)}}\right) \quad (2)$$

The energy, which is converted into heat, is limited by the thermal design of the component.

5.1.4 Timing Diagrams

The power transistors are switched on and off with a dedicated slope via the OUT bits of the serial peripheral interface SPI. The switching times t_{ON} and t_{OFF} are designed equally.

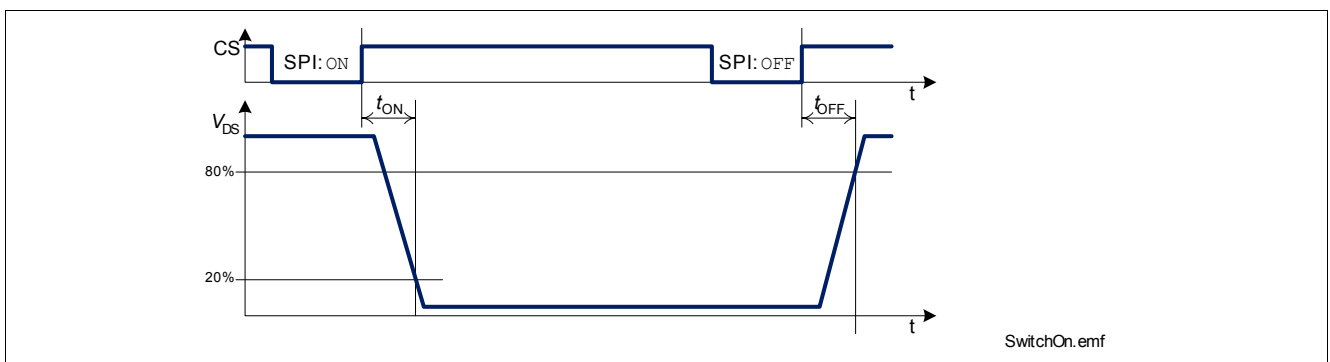

Figure 6 Switching a Resistive Load

When the input mapping is configured accordingly, a high signal at the input pin is equivalent to a SPI ON command.

5.1.5 Electrical Characteristics
Electrical Characteristics: Power Stages

$T_j = -40\text{ °C}$ to 150 °C ; $V_{DD} = 4.5\text{ V}$ to 5.5 V (unless otherwise specified); all voltages with respect to ground, positive current flowing into pin; typical values: $V_{DD} = 5.0\text{ V}$, $T_j = 25\text{ °C}$

Pos.	Parameter	Symbol	Limit Values			Unit	Conditions
			Min.	Typ.	Max.		

Power Supply

5.1.1	Power supply voltage	V_{DD}	4.5	–	5.5	V	–
5.1.2	Power supply current	$I_{DD(ON)}$	–	3	5	mA	all channels ON
5.1.3	Power supply reset current	$I_{DD(RST)}$	–	–	5	μA	$V_{RST} = 0\text{ V}$ $V_{IN} = 0\text{ V}$ $V_{SCLK} = 0\text{ V}$ $V_{SI} = 0\text{ V}$ $V_{CS} = V_{DD}$
5.1.4	Power-on reset threshold voltage	$V_{DD(PO)}$	–	–	4.5	V	–

Output Characteristics

5.1.5	On-State resistance per channel	$R_{DS(ON)}$	–	1.0	1.2 2.1	Ω	$T_j = 25\text{ °C}^{1)}$ $T_j = 150\text{ °C}$ $I_L = 500\text{ mA}$ $V_{DD} = 5\text{ V}$
5.1.6	Nominal load current	$I_{L(nom)}$	240	–	–	mA	¹⁾ all channels ON based on $R_{thJA} = 64\text{ K/W}$ $R_{DS(ON)} = 2.1\text{ }\Omega$ $T_A = 85\text{ °C}$ $T_{j,max} = 150\text{ °C}$
5.1.7	Output leakage current in stand-by mode (per channel)	$I_{D(RST)}$	–	–	1 2 5	μA	$V_{DS} = 13.5\text{ V}$ $T_j = 25\text{ °C}^{1)}$ $T_j = 125\text{ °C}$ $T_j = 150\text{ °C}^{1)}$
5.1.8	Output clamping voltage	$V_{DS(CL)}$	48	–	60	V	–

Input Characteristics

5.1.9	L level of pin IN	$V_{IN(L)}$	0	–	1.0	V	–
5.1.10	H level of pin IN	$V_{IN(H)}$	2.0	–	V_{DD}	V	–
5.1.11	Input voltage hysteresis at pin IN	ΔV_{IN}	–	0.1	–	V	¹⁾
5.1.12	L-input pull-down current through pin IN	$I_{IN(L)}$	10	–	100	μA	¹⁾ $V_{IN} = 1\text{ V}$
5.1.13	H-input pull-down current through pin IN	$I_{IN(H)}$	20	50	100	μA	$V_{IN} = 5\text{ V}$

Block Description and Electrical Characteristics

Electrical Characteristics: Power Stages (cont'd)

$T_j = -40\text{ °C}$ to 150 °C ; $V_{DD} = 4.5\text{ V}$ to 5.5 V (unless otherwise specified); all voltages with respect to ground, positive current flowing into pin; typical values: $V_{DD} = 5.0\text{ V}$, $T_j = 25\text{ °C}$

Pos.	Parameter	Symbol	Limit Values			Unit	Conditions
			Min.	Typ.	Max.		
Reset							
5.1.14	L level of pin RST	$V_{RST(L)}$	0	–	1	V	–
5.1.15	H level of pin RST	$V_{RST(H)}$	2	–	V_{DD}	V	–
5.1.16	L-input pull-up current through pin RST	$I_{RST(L)}$	0	–	10	μA	$V_{RST} = 1\text{ V}$
5.1.17	H-input pull-up current through pin RST	$I_{RST(H)}$	20	50	100	μA	$V_{RST} = 2\text{ V}$

Timings

5.1.18	Power-on wake-up time	$t_{wu(PO)}$	–	–	200	μs	–
5.1.19	Reset duration	$t_{RST(L)}$	10	–	–	μs	–
5.1.20	Turn-on time $V_{DS} = 20\% V_{bat}$	t_{ON}	–	–	15 60	μs	$V_{bat} = 14\text{ V}$ $I_{DS} = 500\text{ mA}$, resistive load $SLE = 0$ $SLE = 1$
5.1.21	Turn-off time $V_{DS} = 80\% V_{bat}$	t_{OFF}	–	–	15 60	μs	$V_{bat} = 14\text{ V}$ $I_{DS} = 500\text{ mA}$, resistive load $SLE = 0$ $SLE = 1$

1) Not subject to production test, specified by design.

Note: Characteristics show the deviation of parameter at the given supply voltage and junction temperature. Typical values show the typical parameters expected from manufacturing.

5.1.6 Command Description

IMCR

Input Mapping Configuration Register

Reset Value: 08_H

7	6	5	4	3	2	1	0
MAP7	MAP6	MAP5	MAP4	MAP3	MAP2	MAP1	MAP0
rw	rw	rw	rw	rw	rw	rw	rw

Field	Bits	Type	Description
MAPn (n = 7-0)	n	rw	<p>Input Mapping Configuration Channel n</p> <p>0 Channel n can not be controlled with mappable input pin IN0. OUT0 is controlled by IN0. OUT2 is controlled by IN2. OUT3 is controlled by the mappable IN3 (default value).</p> <p>1 Channel n can be controlled with mapable input pin IN3, depending on additional set-up.</p>

BOCR

Boolean Operator Configuration Register

Reset Value: 00_H

7	6	5	4	3	2	1	0
BOL7	BOL6	BOL5	BOL4	BOL3	BOL2	BOL1	BOL0
rw	rw	rw	rw	rw	rw	rw	rw

Field	Bits	Type	Description
BOLn (n = 7-0)	n	rw	<p>Boolean Operator Configuration Channel n</p> <p>0 Logic "OR" for channel n (default value). 1 Logic "AND" for channel n.</p>

SRCR

Slew Rate Configuration Register

Reset Value: 00_H

7	6	5	4	3	2	1	0
SLE7	SLE6	SLE5	SLE4	SLE3	SLE2	SLE1	SLE0
rw	rw	rw	rw	rw	rw	rw	rw

Field	Bits	Type	Description
SLEn (n = 7-0)	n	rw	<p>Slew Rate Configuration Channel n</p> <p>0 Channel n is switched fast (default value). 1 Channel n is switched slowly.</p>

CTL

Output Control Register

Reset Value: 00_H

7	6	5	4	3	2	1	0
OUT7	OUT6	OUT5	OUT4	OUT3	OUT2	OUT1	OUT0
rw	rw	rw	rw	rw	rw	rw	rw

Field	Bits	Type	Description
OUTn (n = 7-0)	n	rw	Output Control Channel n 0 Channel n is switched off (default value). 1 Channel n is switched on, depending on additional set-up.

5.2 Protection Functions

The device provides embedded protective functions. Integrated protection functions are designed to prevent IC destruction under fault conditions described in this Data Sheet. Fault conditions are considered as “outside” normal operating range. Protection functions are not designed for continuous repetitive operation.

There is an overload and overtemperature protection implemented in the SPIDER - TLE7232GS. The behavior of the protective functions can be set-up via SPI. Following figure gives an overview about the protective functions.

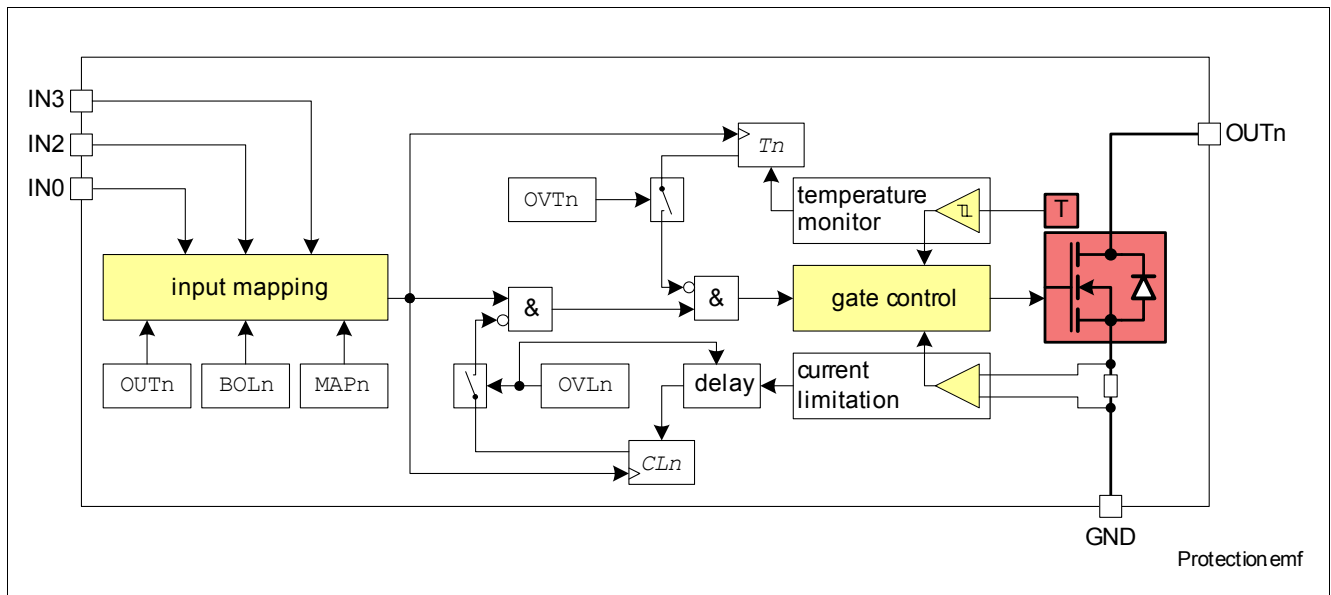

Figure 7 Protective Functions

5.2.1 Overload Protection

The SPIDER - TLE7232GS is protected in case of overload or short circuit of the load. The behavior in case of overload can be configured as follows:

1. The current is limited to $I_{DS(LIM)}$. After time $t_{d(fault)}$, the according overload flag CL_n is set. The channel may shut down due to overtemperature.
2. The current is limited to $I_{DS(LIM)}$. After time $t_{d(off)}$, the overloaded channel n switches off and the according overload flag CL_n is set.

The overload flag (CL_n) of the affected channel is cleared by a low-high transition of the input signal. For timing information, please refer to [Figure 8](#) for details.

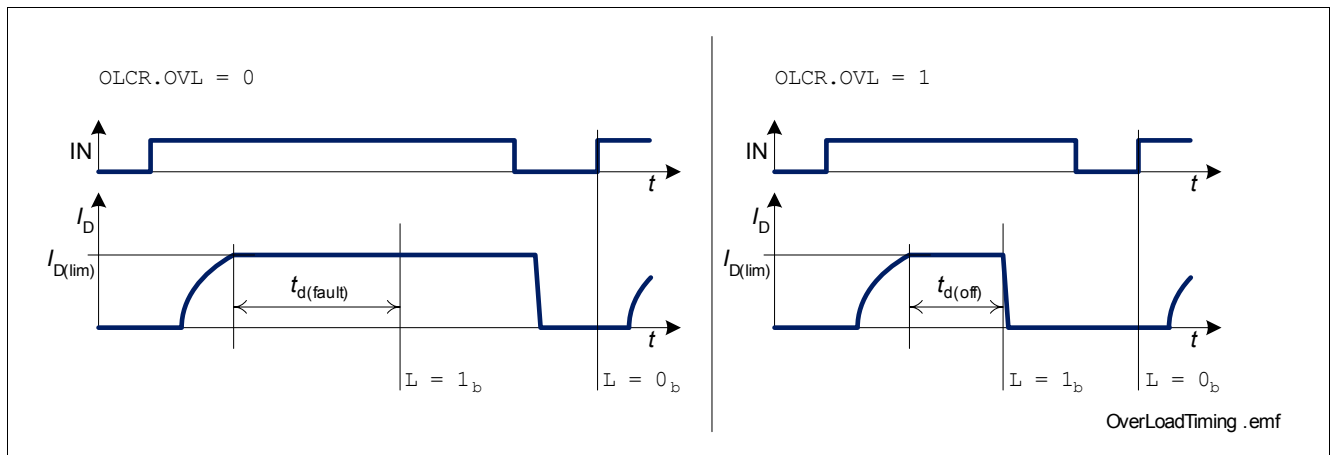

Figure 8 Overload Behavior

5.2.2 Overtemperature Protection

A temperature sensor for each channel causes an overheated channel n to switch off immediately to prevent destruction. The behavior in case of overtemperature can be configured as follows:

1. After cooling down, the channel is switched on again with thermal hysteresis ΔT_j .
2. The affected channel stays switched off until the overtemperature flag is cleared.

The overtemperature flag of the affected channel is cleared by a low-high transition of the input signal.

5.2.3 Reverse Polarity Protection

In case of reverse polarity, the intrinsic body diode of the power transistor causes power dissipation. The reverse current through the intrinsic body diode has to be limited by the connected load. The V_{DD} supply pin must be protected against reverse polarity externally. The overtemperature protection as well as other protective functions are not active during reverse polarity.

5.2.4 Electrical Characteristics

Electrical Characteristics: Protection Functions

$V_{DD} = 4.5\text{ V to }5.5\text{ V}$, $T_j = -40\text{ °C to }150\text{ °C}$, all voltages with respect to ground, positive current flowing into pin (unless otherwise specified); typical values: $V_{DD} = 5.0\text{ V}$, $T_j = 25\text{ °C}$

Pos.	Parameter	Symbol	Limit Values			Unit	Conditions
			Min.	Typ.	Max.		
Overload Protection							
5.2.1	Overload current limitation	$I_{D(lim)}$	1	–	2	A	OVL = 0
5.2.2	Overload shut-down delay time	$t_{d(off)}$	10	–	50	µs	OVL = 1
Overtemperature Protection							
5.2.3	Overtemperature shut-down threshold	$T_{j(OT)}$	170	–	200	°C	1)
5.2.4	Thermal hysteresis	$\Delta T_{j(OT)}$	–	10	–	K	1)

1) Not subject to production test, specified by design.

5.2.5 Command Description

OLCR

Overload Configuration Register

Reset Value: 00_H

7	6	5	4	3	2	1	0
OVL7	OVL6	OVL5	OVL4	OVL3	OVL2	OVL1	OVL0
rw	rw	rw	rw	rw	rw	rw	rw

Field	Bits	Type	Description
OVLn (n = 7-0)	n	rw	Overload Configuration Channel n 0 Channel n limits the current in case of overload (default value). 1 Channel n shuts down in case of overload.

OTCR

Overtemperature Configuration Register

Reset Value: 00_H

7	6	5	4	3	2	1	0
OVT7	OVT6	OVT5	OVT4	OVT3	OVT2	OVT1	OVT0
rw	rw	rw	rw	rw	rw	rw	rw

Field	Bits	Type	Description
OVTn (n = 7-0)	n	rw	Overtemperature Configuration Channel n 0 Autorestart (default value) 1 Latched shut down

5.3 Diagnostic Features

The SPI of SPIDER - TLE7232GS provides diagnosis information about the device and about the load. There are following diagnosis flags implemented:

- The diagnosis information of the protective functions (flags CL_n and T_n) of channel n is latched in the diagnosis flag P_n .
- The open load diagnosis of channel n is latched in the diagnosis flag OL_n .
- The short to GND monitor information of channel n is latched in the diagnosis flag SG_n .

All flags are cleared after a successful SPI transmission.

There is an output state monitor implemented in the device that indicates the switch state of the device in register STA . Depending on the voltage level at input pin and protective functions the bits are high or low.

Please see [Figure 9](#) for details:

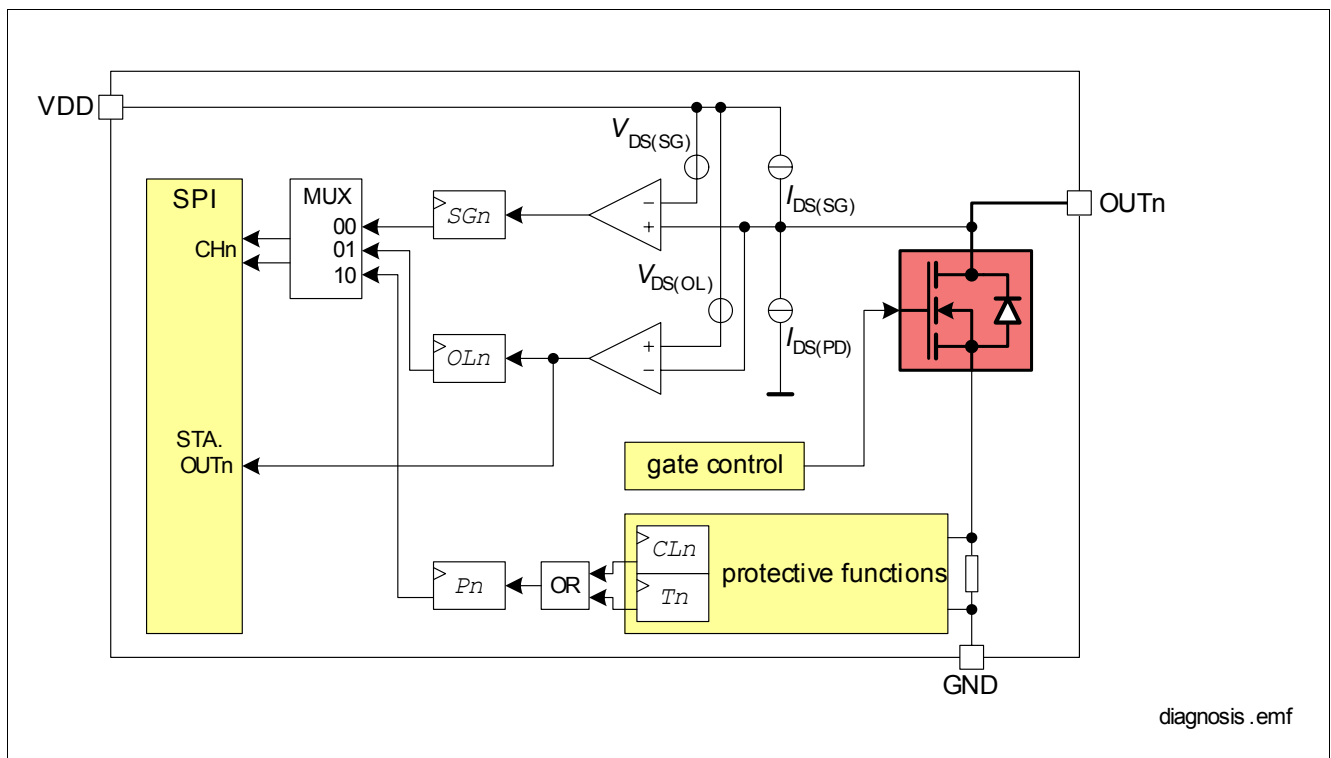

Figure 9 Block Diagram Diagnosis

5.3.1 Diagnosis Timing

The SPIDER - TLE7232GS offers 2 different diagnosis for each channel in OFF mode.

5.3.1.1 Open Load Behavior

The device offers a open load diagnosis for each channel in OFF mode.

The time $t_{d(\text{fault})}$ is applied to filter short time events.

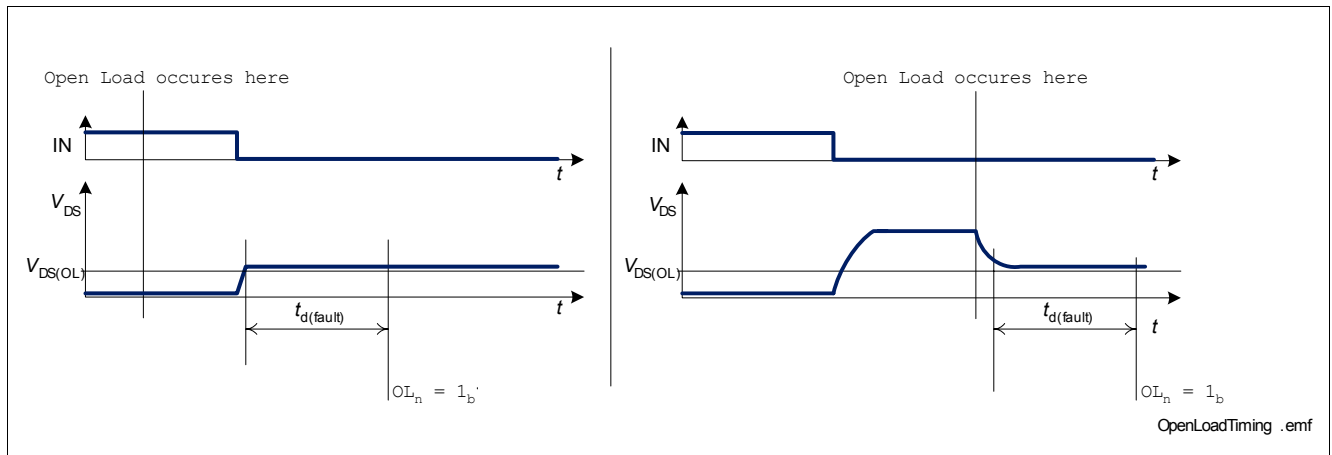

Figure 10 Open Load Timing

5.3.1.2 Short to Ground Behavior

The device offers a short to ground detection for each channel in OFF mode.

The time $t_{d(\text{fault})}$ is applied to filter short time events.

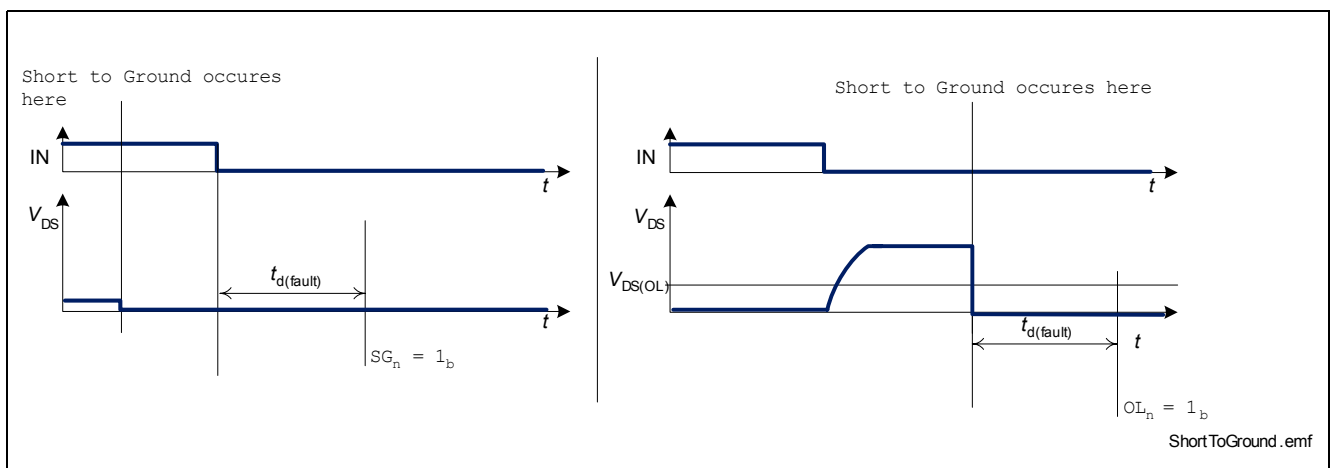

Figure 11 Short to Ground Timing

5.3.2 Electrical Characteristics

Electrical Characteristics: Diagnostic

$V_{DD} = 4.5\text{ V to }5.5\text{ V}$, $T_j = -40\text{ °C to }150\text{ °C}$, all voltages with respect to ground, positive current flowing into pin (unless otherwise specified); typical values: $V_{DD} = 5.0\text{ V}$, $T_j = 25\text{ °C}$

Pos.	Parameter	Symbol	Limit Values			Unit	Conditions
			Min.	Typ.	Max.		
OFF State Diagnosis							
5.3.1	Open load detection threshold voltage	$V_{DS(OL)}$	$V_{DD} - 2.5$	$V_{DD} - 2$	$V_{DD} - 1.3$	V	–
5.3.2	Output pull-down diagnosis current per channel	$I_{D(PD)}$	50	90	150	μA	–
5.3.3	Short to GND detection threshold voltage	$V_{DS(SG)}$	$V_{DD} - 3.4$	$V_{DD} - 3.0$	$V_{DD} - 2.6$	V	–
5.3.4	Output diagnosis current for short to GND per channel	$I_{D(SG)}$	-150	-100	-50	μA	$V_{DS} = 0\text{ V}$
5.3.5	Fault delay time	$t_{d(\text{fault})}$	50	100	200	μs	–

5.3.3 Command Description

STA

Output Status Monitor

Reset Value: 00_H

7	6	5	4	3	2	1	0
OUT7	OUT6	OUT5	OUT4	OUT3	OUT2	OUT1	OUT0
r	r	r	r	r	r	r	r

Field	Bits	Type	Description
OUTn (n = 7-0)	n	r	Output Status 0 Voltage level at channel n: $V_{DS} > V_{DS(OL)}$ 1 Voltage level at channel n: $V_{DS} < V_{DS(OL)}$

5.4 Serial Peripheral Interface (SPI)

The diagnosis and control interface is based on a serial peripheral interface (SPI).

The SPI is a full duplex synchronous serial slave interface, which uses four lines: SO, SI, SCLK and $\overline{\text{CS}}$. Data is transferred by the lines SI and SO at the data rate given by SCLK. The falling edge of $\overline{\text{CS}}$ indicates the beginning of a data access. Data is sampled in on line SI at the falling edge of SCLK and shifted out on line SO at the rising edge of SCLK. Each access must be terminated by a rising edge of $\overline{\text{CS}}$. A modulo 8 counter ensures that data is taken only, when a multiple of 8 bit has been transferred. The interface provides daisy chain capability.

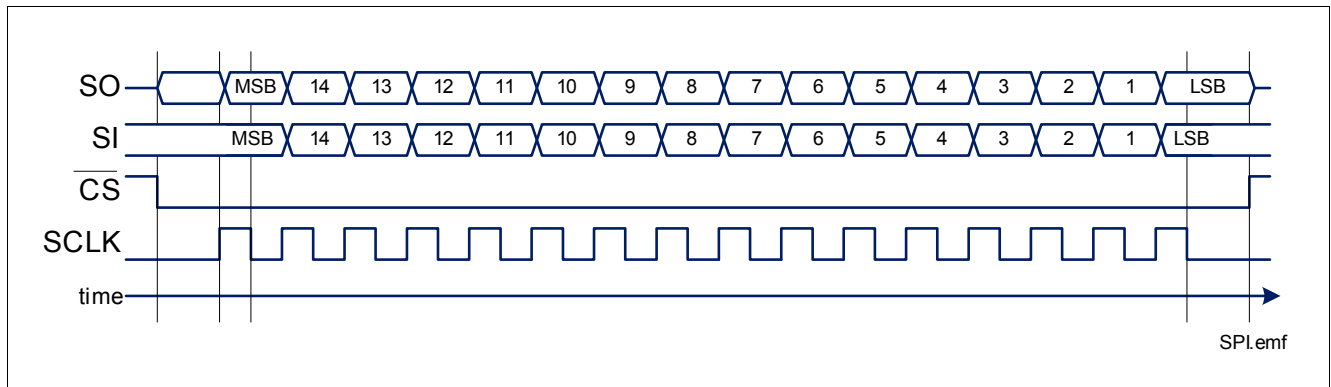

Figure 12 Serial Peripheral Interface

The SPI protocol is described in [Section 5.4.5](#). It is reset to the default values after power-on reset or a low signal at pin RST.

5.4.1 SPI Signal Description

$\overline{\text{CS}}$ - Chip Select: The system microcontroller selects the SPIDER - TLE7232GS by means of the $\overline{\text{CS}}$ pin. Whenever the pin is in low state, data transfer can take place. When $\overline{\text{CS}}$ is in high state, any signals at the SCLK and SI pins are ignored and SO is forced into a high impedance state.

$\overline{\text{CS}}$ High to Low Transition: 

- The diagnosis information is transferred into the shift register.

$\overline{\text{CS}}$ Low to High Transition: 

- Command decoding is only done, when after the falling edge of $\overline{\text{CS}}$ exactly a multiple (1, 2, 3, ...) of eight SCLK signals have been detected.
- Data from shift register is transferred into the input matrix register.
- The diagnosis flags are cleared.

SCLK - Serial Clock: This input pin clocks the internal shift register. The serial input (SI) transfers data into the shift register on the falling edge of SCLK while the serial output (SO) shifts diagnostic information out on the rising edge of the serial clock. It is essential that the SCLK pin is in low state whenever chip select $\overline{\text{CS}}$ makes any transition.

SI - Serial Input: Serial input data bits are shifted in at this pin, the most significant bit first. SI information is read on the falling edge of SCLK. The 16 bit input data consist of two parts (control and data). Please refer to [Section 5.4.5](#) for further information.

SO Serial Output: Data is shifted out serially at this pin, the most significant bit first. SO is in high impedance state until the $\overline{\text{CS}}$ pin goes to low state. New data will appear at the SO pin following the rising edge of SCLK. Please refer to [Section 5.4.5](#) for further information. The high state output voltage depends on the voltage at pin V_{SO} .

5.4.2 Daisy Chain Capability

The SPI of SPIDER - TLE7232GS provides daisy chain capability. In this configuration several devices are activated by the same \overline{CS} signal \overline{MCS} . The SI line of one device is connected with the SO line of another device (see Figure 13), which builds a chain. The ends of the chain are connected with the output and input of the master device, MO and MI respectively. The master device provides the master clock MCLK, which is connected to the SCLK line of each device in the chain.

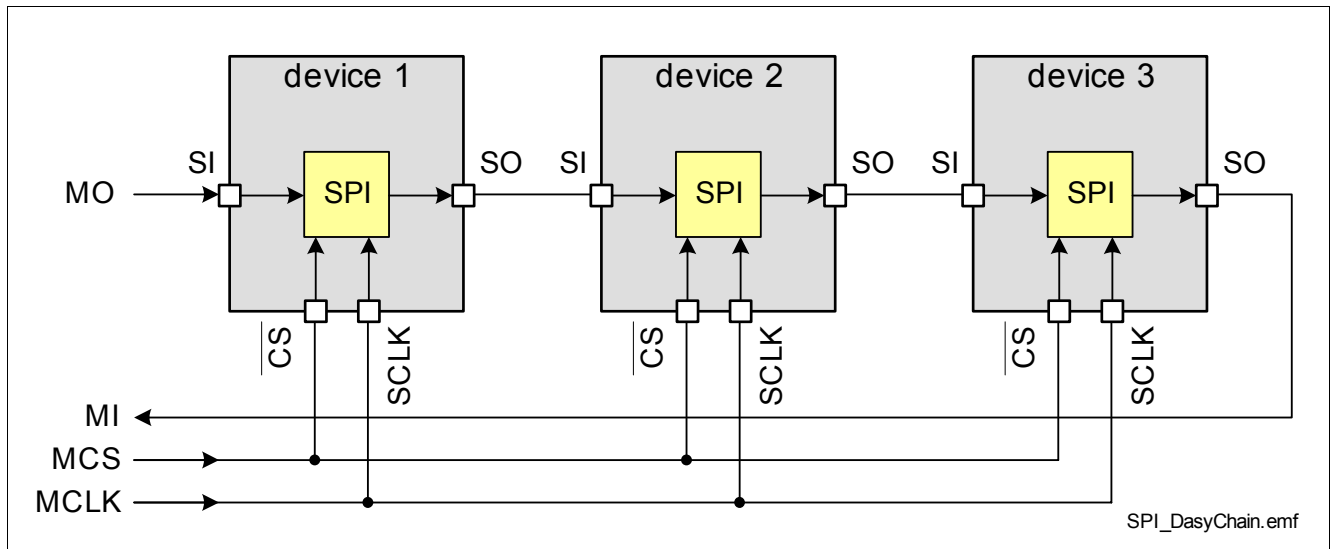

Figure 13 Daisy Chain Configuration

In the SPI block of each device, there is one shift register where one bit from SI line is shifted in each SCLK. The bit shifted out can be seen at SO. After 16 SCLK cycles, the data transfer for one device has been finished. In single chip configuration, the \overline{CS} line must go high to make the device accept the transferred data. In daisy chain configuration the data shifted out at device #1 has been shifted in to device #2. When using three devices in daisy chain, three times 16 bits have to be shifted through the devices. After that, the \overline{MCS} line must go high (see Figure 14).

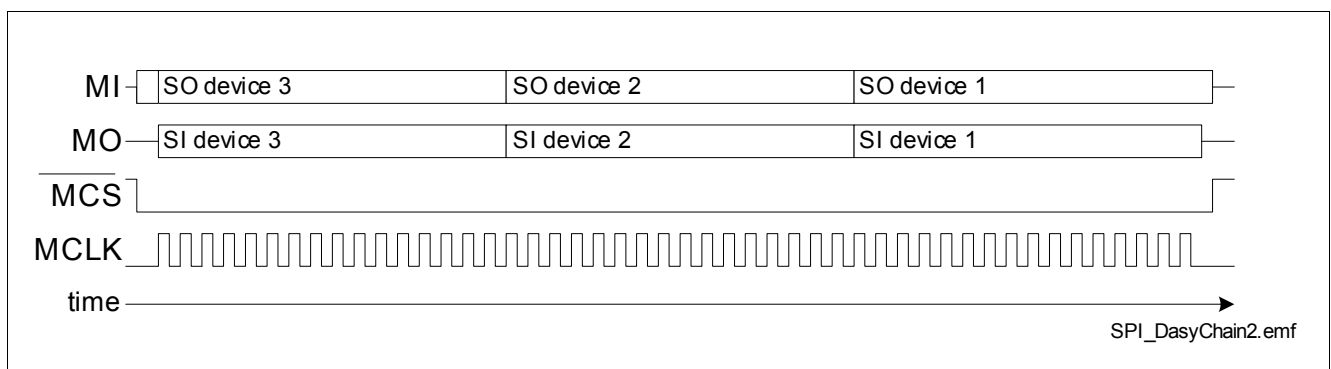

Figure 14 Data Transfer in Daisy Chain Configuration

5.4.3 Timing Diagrams

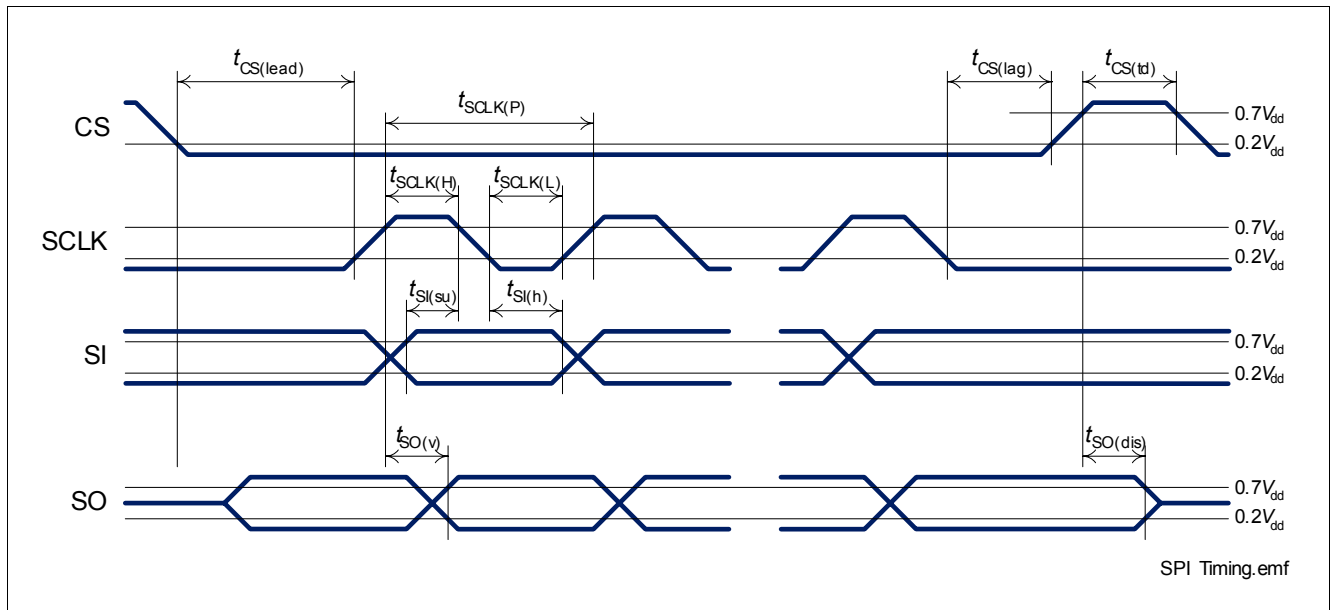

Figure 15 Timing Diagram

5.4.4 Electrical Characteristics

Electrical Characteristics: SPI

$V_{DD} = 4.5 \text{ V to } 5.5 \text{ V}$, $T_j = -40 \text{ }^\circ\text{C to } 150 \text{ }^\circ\text{C}$, all voltages with respect to ground, positive current flowing into pin (unless otherwise specified); typical values: $V_{DD} = 5.0 \text{ V}$, $T_j = 25 \text{ }^\circ\text{C}$

Pos.	Parameter	Symbol	Limit Values			Unit	Conditions
			Min.	Typ.	Max.		
Power Supply							
5.4.1	Power supply voltage for SO buffer	V_{VSO}	3.0	–	5.5	V	–
Input Characteristics (CS, SCLK, SI)							
5.4.2	L level of pin CS SCLK SI	$V_{CS(L)}$ $V_{SCLK(L)}$ $V_{SI(L)}$	0	–	1	V	–
5.4.3	H level of pin CS SCLK SI	$V_{CS(H)}$ $V_{SCLK(H)}$ $V_{SI(H)}$	2	–	V_{DD}	V	–
5.4.4	L-input pull-up current through CS	$I_{CS(L)}$	10	20	50	μA	$V_{CS} = 0 \text{ V}$
5.4.5	H-input pull-up current through CS	$I_{CS(H)}$	5	–	50	μA	¹⁾ $V_{CS} = 2 \text{ V}$
5.4.6	L-input pull-down current through pin SCLK SI	$I_{SCLK(L)}$ $I_{SI(L)}$	5 5	– –	50 50	μA	¹⁾ $V_{SCLK} = 1 \text{ V}$ $V_{SI} = 1 \text{ V}$

Block Description and Electrical Characteristics
Electrical Characteristics: SPI (cont'd)

$V_{DD} = 4.5\text{ V to }5.5\text{ V}$, $T_j = -40\text{ °C to }150\text{ °C}$, all voltages with respect to ground, positive current flowing into pin (unless otherwise specified); typical values: $V_{DD} = 5.0\text{ V}$, $T_j = 25\text{ °C}$

Pos.	Parameter	Symbol	Limit Values			Unit	Conditions
			Min.	Typ.	Max.		
5.4.7	H-input pull-down current through pin SCLK SI	$I_{SCLK(H)}$	10	20	50	μA	$V_{SCLK} = 5\text{ V}$ $V_{SI} = 5\text{ V}$
		$I_{SI(H)}$	10	20	50		

Output Characteristics (SO)

5.4.8	L level output voltage	$V_{SO(L)}$	0	–	0.4	V	$I_{SO} = -2.5\text{ mA}$
5.4.9	H level output voltage	$V_{SO(H)}$	–	–	–	–	$I_{SO} = 2\text{ mA}$ $V_{VSO} = 5\text{ V}$ $V_{VSO} = 3\text{ V}$
			4.6	–	5		
			2.4	–	3		
5.4.10	Output tristate leakage current	$I_{SO(OFF)}$	-10	–	10	μA	$V_{CS} = V_{DD}$

Timings

5.4.11	Serial clock frequency	f_{SCLK}	0	–	5	MHz	–
5.4.12	Serial clock period	$t_{SCLK(P)}$	200	–	–	ns	–
5.4.13	Serial clock high time	$t_{SCLK(H)}$	50	–	–	ns	–
5.4.14	Serial clock low time	$t_{SCLK(L)}$	50	–	–	ns	–
5.4.15	Enable lead time (falling \overline{CS} to rising SCLK)	$t_{SCLK(lead)}$	250	–	–	ns	–
5.4.16	Enable lag time (falling SCLK to rising \overline{CS})	$t_{SCLK(lag)}$	250	–	–	ns	–
5.4.17	Transfer delay time (rising \overline{CS} to falling \overline{CS})	$t_{CS(del)}$	250	–	–	ns	–
5.4.18	Data setup time (required time SI to falling SCLK)	$t_{SI(su)}$	20	–	–	ns	–
5.4.19	Data hold time (falling SCLK to SI)	$t_{SI(h)}$	20	–	–	ns	–

1) Not subject to production test, specified by design.

5.4.5 SPI Protocol

The SPI protocol of the SPIDER - TLE7232GS provides two types of registers. The control registers and the diagnosis registers. After power-on reset, all register bits set to default values.

SI

Reset Value: $xxxx_H$

15	14	13	12	11	10	9	8	7	6	5	4	3	2	1	0
CMD		0	0	0	ADDR			DATA							

Field	Bits	Type	Description
CMD	15:14		Command 00 Diagnosis only: The requested data is shifted out at SO. This command does not change any register setting. 01 Read register: The register content of the addressed register will be sent in the next frame. 10 Reset registers: All registers are reset to their default values. 11 Write register: The data of the SI word will be written to the addressed register.
ADDR	10:8		Address Pointer to register for read and write command
DATA	7:0		Data Data written to or read from register selected by address ADDR

SO

Standard Diagnosis

Reset Value: $xxxx_H$

15	14	13	12	11	10	9	8	7	6	5	4	3	2	1	0
CH7		CH6		CH5		CH4		CH3		CH2		CH1		CH0	

Field	Bits	Type	Description
CHn (n = 7-0)	(2n+1):2n		Standard Diagnosis for Channel n 00 Short circuit to GND 01 Open load 10 Overload, overtemperature 11 Normal operation

SO

Second Frame of Read Command

Reset Value: $xxxx_H$

15	14	13	12	11	10	9	8	7	6	5	4	3	2	1	0
0	1	0	0	0	ADDR			DATA							

Block Description and Electrical Characteristics

Field	Bits	Type	Description
ADDR	10:8		Address Pointer to register for read and write command
DATA	7:0		Data Data written to or read from register selected by address ADDR

Note: Reading a register needs two SPI frames. In the first frame the RD command is sent. In the second frame the output at SPI signal SO will contain the requested information. A new command can be executed in the second frame.

5.4.6 Register Overview

Name	W/R	Addr	7	6	5	4	3	2	1	0	Default ¹⁾
IMCR	W/R	001 _B	MAP7	MAP6	MAP5	MAP4	MAP3	MAP2	MAP1	MAP0	08 _H
BOCR	W/R	010 _B	BOL7	BOL6	BOL5	BOL4	BOL3	BOL2	BOL1	BOL0	00 _H
OLCR	W/R	011 _B	OVL7	OVL6	OVL5	OVL4	OVL3	OVL2	OVL1	OVL0	00 _H
OTCR	W/R	100 _B	OVT7	OVT6	OVT5	OVT4	OVT3	OVT2	OVT1	OVT0	00 _H
SRCR	W/R	101 _B	SLE7	SLE6	SLE5	SLE4	SLE3	SLE2	SLE1	SLE0	00 _H
STA	R	110 _B	OUT7	OUT6	OUT5	OUT4	OUT3	OUT2	OUT1	OUT0	00 _H
CTL	W/R	111 _B	OUT7	OUT6	OUT5	OUT4	OUT3	OUT2	OUT1	OUT0	00 _H

1) The default values are set after reset.

Due to the default value of the mapping register the IN3 is mapped to OUT3 after power up.

6 Application Circuit

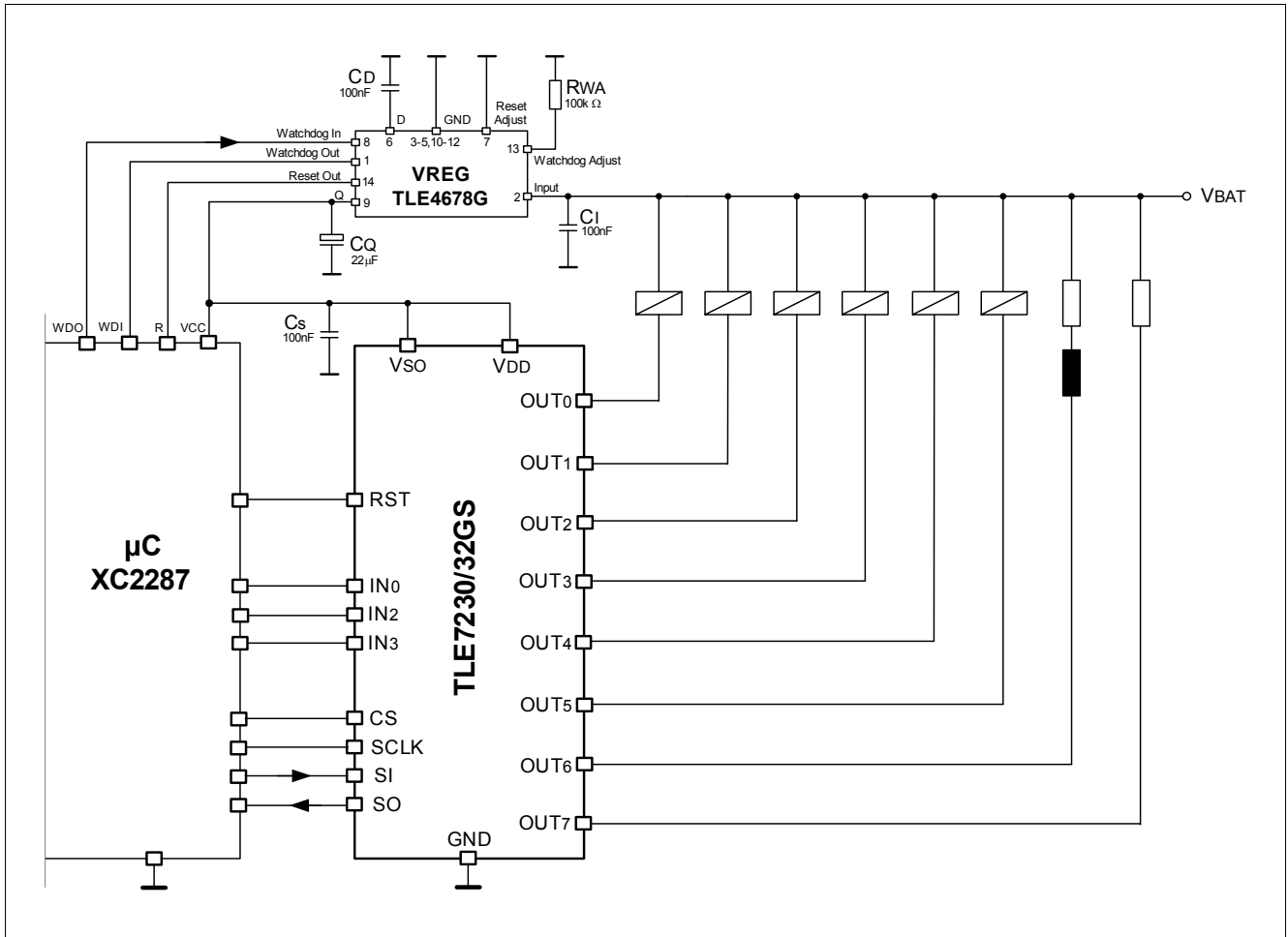

Figure 16 Application Circuit

8 Revision History

Revision	Date	Changes
Rev. 1.0	2007-12-18	layout completely updated (A4 page size)
		Application circuit added
		Nominal load current inserted (page 14)
		Thermal Resistance section (page 15) updated

Edition 2007-12-18

**Published by
Infineon Technologies AG
81726 Munich, Germany**

**© 2007 Infineon Technologies AG
All Rights Reserved.**

Legal Disclaimer

The information given in this document shall in no event be regarded as a guarantee of conditions or characteristics. With respect to any examples or hints given herein, any typical values stated herein and/or any information regarding the application of the device, Infineon Technologies hereby disclaims any and all warranties and liabilities of any kind, including without limitation, warranties of non-infringement of intellectual property rights of any third party.

Information

For further information on technology, delivery terms and conditions and prices, please contact the nearest Infineon Technologies Office (www.infineon.com).

Warnings

Due to technical requirements, components may contain dangerous substances. For information on the types in question, please contact the nearest Infineon Technologies Office.

Infineon Technologies components may be used in life-support devices or systems only with the express written approval of Infineon Technologies, if a failure of such components can reasonably be expected to cause the failure of that life-support device or system or to affect the safety or effectiveness of that device or system. Life support devices or systems are intended to be implanted in the human body or to support and/or maintain and sustain and/or protect human life. If they fail, it is reasonable to assume that the health of the user or other persons may be endangered.