

1.SCOPE

SHOULDER's SAW filter series have broad line up products meeting all broadcast standard including NTSC,PAL and SECAM systems. These filters are composed of two interdigital transducers on a single-crystal, piezoelectrical chip. they are used in electronic equipments such as TV and so on.

2.Construction

2.1 Dimension and materials

Type : BF42A1M

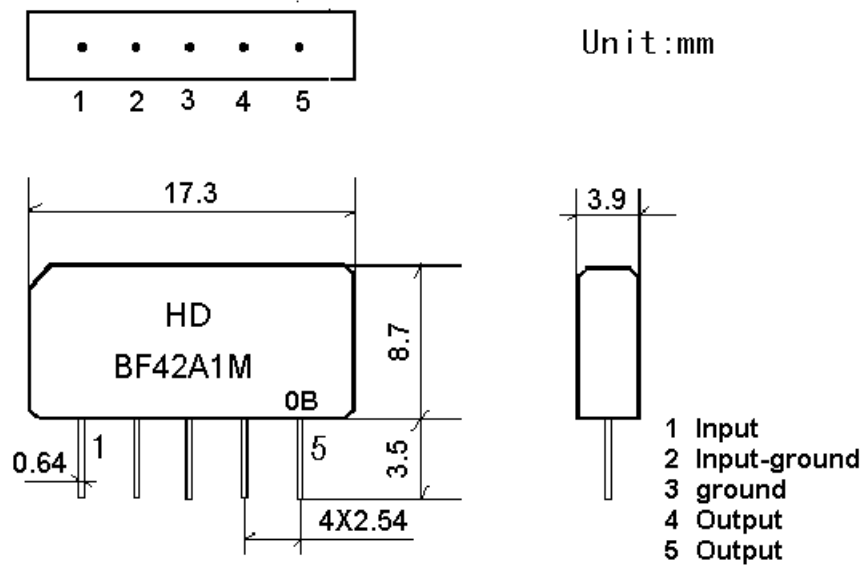

0: year(0,1,2,3,4,5,6,7,8,9)

B:product in this quarter(A:1~3,B:4~6,C:7~9,D:10~12)

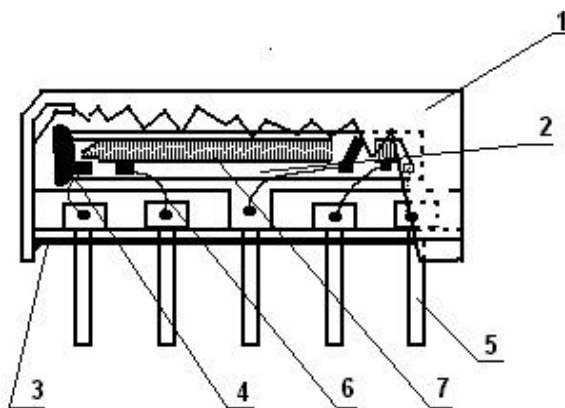

Components	Materials
1.Outer casing	PPS
2.Substrate	Lithium niobate
3.Base	Epoxy resin
4.Absorber	Epoxy resin
5.Lead	Cu alloy+Au plate
6.Bonding wire	AlSi alloy
7.Electrode	Al

2.2. Circuit construction, measurement circuit

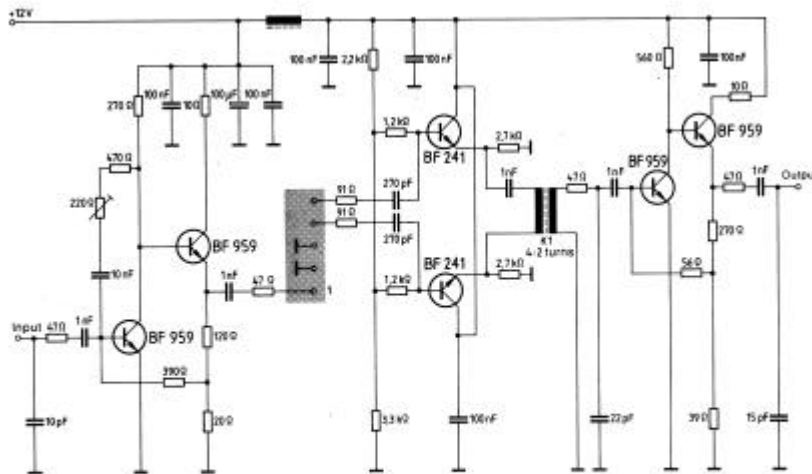

Test circuit for SIP-5 filter
Input impedance of the symmetrical post-amplifier: 2 kΩ in parallel with 3 pF

3.Characteristics

Standard atmospheric conditions

Unless otherwise specified , the standard rang of atmospheric conditions for making measurements and tests is as follows;

- Ambient temperature : 15 to 35
- Relative humidity : 25% to 85%
- Air pressure : 86kPa to 106kPa

Operating temperature rang

Operating temperature rang is the rang of ambient temperatures in which the filter can be operated continuously. -10 ~ +60

Storage temperature rang

Storage temperature rang is the rang of ambient temperatures at which the filter can be stored without damage.

Conditions are as specified elsewhere in these specifications. -40 ~ +70

Reference temperature +25

3.1 Maximum Rating

DC voltage	VDC	12	V	Between any terminals
AC voltage	Vpp	10	V	Between any terminals

3.2 Electrical Characteristics

Source impedance

$Z_s=50$

Load impedance

$Z_L=2k \ //3pF$

$T_A=25$

Item	Freq	min	typ	max	
Center frequency	Fo	-	42.0	-	MHz
Insertion attenuation Reference level	42.00MHz	-	14.5	-	dB
Pass bandwidth	B _{3dB}	6.0	-	-	MHz
	B _{30dB}	-	-	8.0	MHz
Sidelobe	32.00~37.00MHz	35.0	40.0		dB
	47.00~52.00MHz	35.0	40.0		dB
Temperature coefficient		-72			ppm/k

3.3 Environmental Performance Characteristics

Item Test condition	Allowable change of absolute Level at center frequency(dB)
High temperature test 70 16H ,	< 1.0
Low temperature test -25 2H	< 1.0
Humidity test 40 90-95% 100H	< 1.0
Thermal cycle -25 ==70 3cycle 30min. 5min. 30min.	< 1.0
Solder temperature test Sold temp.260 for 10 sec.	< 1.0
Soldering Immerse the pins melt solder at 260 +5/-0 for 5 sec.	More then 95% of total area of the pins should be covered with solder

3.4 Mechanical Test

Item Test condition	Allowable change of absolute Level at center frequency(dB)
Vibration test Frequency 10~55Hz amplitude 1.5mm 3 directions 2 H each	<1.0
Drop test On maple plate frome 1 m high 3 times	<1.0
Lead pull test Pull with 1 kg force for 30 seconds	<1.0
Lead bend test 90° bending with 500g weigh 2 times	<1.0

3.5 Voltage Discharge Test

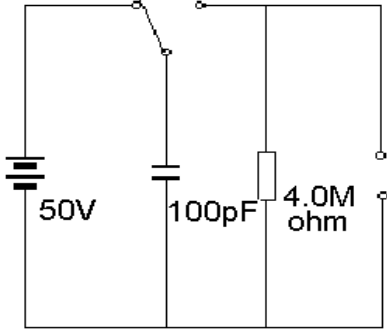
Item Test condition	Allowable change of absolute Level at center frequency(dB)
Surge test Between any two electrode 	<1.0