

17-30W DC/DC power modules 48V Input series

- Efficiency typ 90% from 30% to full load for 3.3V converter
- Output current up to 14A
- Meets lead-free soldering processes up to 260°C
- Low profile 7.5 mm (0.295 in.)
- 1500 Vdc isolation voltage
- MTBF >5,100,000 hours at +75°C case temperature
- Full power up to +70°C ambient at 1 m/s airflow
- Complete, no extra heatsinks required

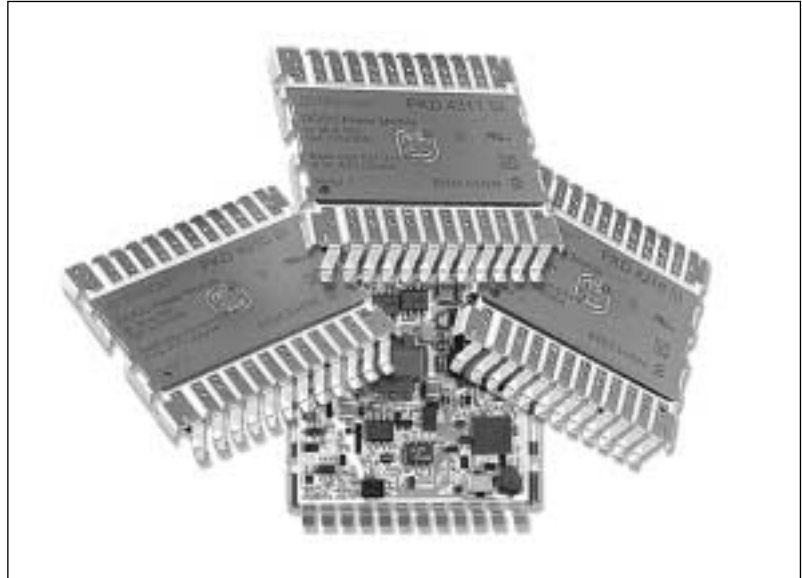

The PKD 4000 SI series of DC/DC power modules are intended to be used as distributed power sources in decentralized 48/60VDC power systems. The PKD series use a ceramic substrate with thickfilm technology and a high degree of silicon integration. That, together with the electrical design using synchronous rectification gives good thermal management, high reliability and high efficiency.

The high efficiency makes it possible to operate over a wide temperature range without a heatsink. At forced convection cooling >200lfm (1m/s), the PKD units

can deliver full power up to +70°C ambient temperature. The high reliability and the low profile of the PKD series makes them particularly suited for Information Technology and Telecom (IT&T) applications with board spacing down to 15mm (0.6 in.).

These products are manufactured using highly automated manufacturing lines with a world-class quality commitment and a five-year warranty.

Ericsson Power Modules AB is an ISO 9001/14001 certified supplier.

General

Absolute Maximum Ratings

Characteristics		min	max	Unit
T _C	Case temperature at max output power ¹⁾	-45	+100	°C
T _S	Storage temperature	-55	+125	°C
V _I	Input voltage	-0.5	+80	Vdc
V _{ISO}	Isolation voltage (Input to output test voltage)	1500		Vdc
V _{RO}	Remote on/off voltage pin 5	-0.5	+6 +9	Vdc
V _{adj}	Output adjust voltage pin 16 ²⁾	-0.5	2xV _{Oi}	Vdc

¹⁾ Measured on pin 22.

²⁾ V_{Oi} = initial output voltage setting.

Stress in excess of Absolute Maximum Ratings may cause permanent damage. Absolute Maximum Ratings, sometimes referred to as no destruction limits, are normally tested with one parameter at a time exceeding the limits of Output data or Electrical Characteristics. If exposed to stress above these limits, function and performance may degrade in an unspecified manner.

Input T_C < T_C max

Characteristics		Conditions	min	typ	max	Unit
V _I	Input voltage range ¹⁾		36		75	V
V _{Ioff}	Turn-off input voltage	(See operating information)	32			V
V _{Ion}	Turn-on input voltage	See operating information)			36	V
C _i	Input Capacitance			1.4		µF
P _{ii}	Input idling power	I _O = 0, V _I = 53 V		2.0		W
P _{Ist-by}	Input stand-by power ¹⁾	V _I = 53 V		0.5		W

¹⁾ With module inhibited with RC pin no 5.

Environmental Characteristics

Characteristics		Test procedure & conditions	
Random vibration	IEC 68-2-34 Ed	Frequency Spectral density Duration	10 ... 500 Hz 0.025 g ² /Hz 15 min each direction
Bump	IEC 68-2-29 Test Eb	Peak acceleration Duration Directions number of bumps	40 g 6 ms 6 1000/direction
Shock (Half sinus)	IEC 68-2-27	Peak acceleration Shock duration	200 g 0.5 ms
Temperature change	JESD 22-A104 (IEC 68-2-14 N _a)	Temperature Number of cycles	-40 ... +125 °C 300
Operational Lifetime test		Case temperature Load Input voltage Duration	100 °C Nominal Max 1000 h
Accelerated damp heat	IEC 68-2-3 Ca with bias. Nominal input voltage	Temperature Humidity Duration	85 °C 85 % RH 1000 hours
Resistance to cleaning solvents	IEC 68-2-45 XA Method 1	Water Isopropyl alcohol Glycol ether Method	+55 ±5 °C +35 ±5 °C +35 ±5 °C with rubbing
Moisture / Reflow sensitivity classification	IPC/JEDEC J-STD-020A	Level 1	High Temperature Reflow (See page 17)

Safety

The PKD 4000 SI Series DC/DC converters are designed in accordance with Safety standards IEC/EN/UL 60 950, *Safety of Information Technology Equipment*.

The PKD 4000 SI Series DC/DC converters are UL 60950 recognized and certified in accordance with EN 60 950.

The DC/DC converter should be installed in the end-use equipment in accordance with the requirements of the ultimate equipment. The input source must be isolated by minimum Basic Insulation from the primary circuit in accordance with IEC/EN/UL 60950.

If the input voltage to the DC/DC converter is 75 V dc or less, then the output remains SELV (Safety Extra Low Voltage) under normal and abnormal conditions.

Single fault testing in the input power source circuit should be performed with the DC/DC converter connected to demonstrate that the input voltage does not exceed 75 V dc. If the input power source circuit is a DC power system, the source may be treated as a TNV2 circuit and testing has demonstrated compliance with SELV limits and isolation requirements equivalent to Basic Insulation in accordance with IEC/EN/UL 60 950.

It is recommended that a fast blow fuse with a rating of 2.5 A be used at the input of each DC/DC converter. The PKD 4000 SI series DC/DC converters are approved for a maximum fuse rating of 15 A. If a fault occurs in the DC/DC converter that imposes a short circuit on the input power source, this fuse will provide the following functions

- Isolate the faulty DC/DC converter from the input power source not to affect the operation of other parts of the system.
- Protect the distribution wiring from excessive current and power loss thus preventing hazardous overheating

The galvanic isolation is verified in an electric strength test. The test voltage (V_{ISO}) between input and output is 1,500 V dc for 60 s. Leakage current is less than 1 µA at nominal input voltage.

The flammability rating for all construction parts of the DC/DC converter meets UL 94V-0.

Note:

1) The input voltage range 36...75 V meets the requirements in the European Telecom Standard prETS 300 132-2 for Normal input voltage range in 48 V and 60 V DC power systems, -40.5...-57.0 V and -50.0...-72.0 V respectively.

Mechanical Data

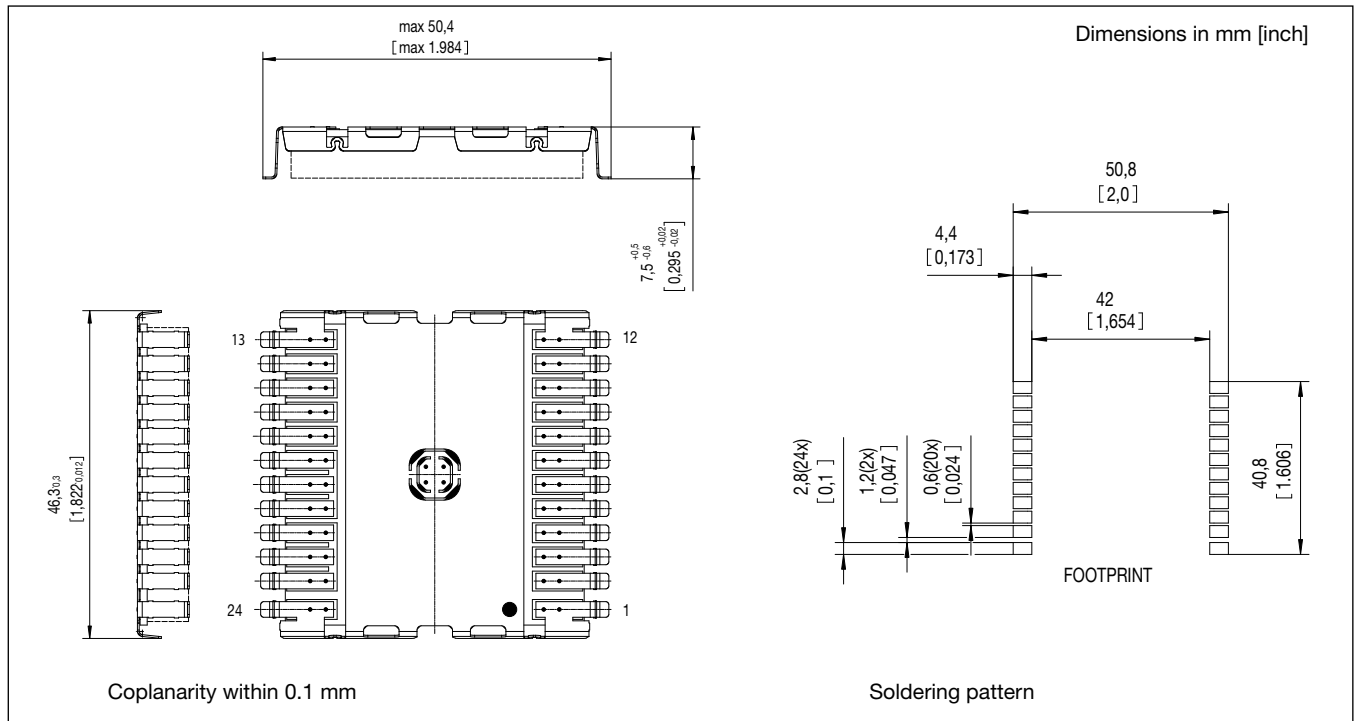

Connections

Pin	Designation	Function
1	Case	Case connection. ¹⁾
2	+In	Positive input
3	-In	Negative input
4	NC	Not connected
5	RC	Remote control pin
6	RCS	For SI versions - Do not connect For SIN versions - Connect to -In
7-11	NC	Not connected
12	Case	Case connection. ¹⁾
13	Case	Case connection. ¹⁾
14	NC	Not connected
15	+Sen	Positive remote sense
16	Vadj	Output voltage adjust
17	-Sen	Negative remote sense
18-20	-Out	Negative output
21-23	+Out	Positive output
24	Case	Case connection. ¹⁾

¹⁾ Case is floating and may be connected either to +V_{In} ; -V_{In} ; +V_{out} ; -V_{out} to optimize EMI performance.

Weight

Maximum: 22g.

Case

The cover is a part of the leadframe and functions as the pick and place surface, shielding and additional heatsinking.

Electrical Data

Fundamental circuit diagram Single output

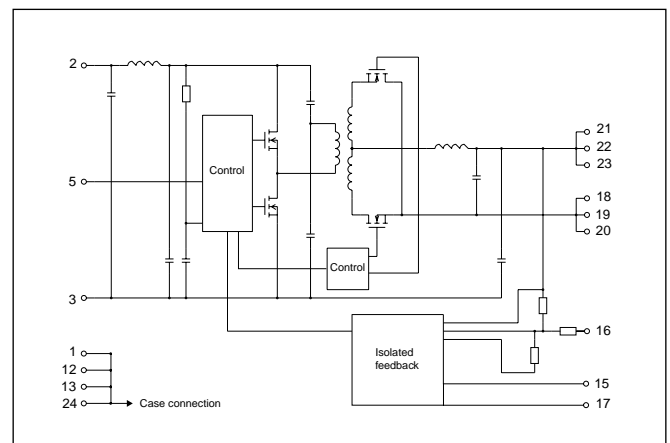

PKD 4118 SIOD

$T_C = -25 \dots +90^\circ\text{C}$, $V_I = 36 \dots 75\text{V}$ unless otherwise specified.

Output

Characteristics		Conditions		Output 1			Unit
				min	typ	max	
V_{O_i}	Output voltage initial setting and accuracy	$T_C = +25^\circ\text{C}$, $I_O = I_{O_{\max}}$, $V_I = 53\text{V}$		1.19	1.20	1.21	V
	Output adjust range ¹⁾			1.08		1.32	
V_O	Output voltage tolerance band	Long term drift included	$I_O = 0.1 \dots 1.0 \times I_{O_{\max}}$	1.15		1.25	V
	Idling voltage	$I_O = 0$		1.15		1.25	
	Line regulation	$I_O = I_{O_{\max}}$				5	mV
	Load regulation	$I_O = 0.01 \dots 1.0 \times I_{O_{\max}}$, $V_I = 53\text{V}$				5	mV
t_{tr}	Load transient recovery time	$I_O = 0.1 \dots 1.0 \times I_{O_{\max}}$, $V_I = 53\text{V}$ load step = $0.5 \times I_{O_{\max}}$			100		μs
V_{tr}	Load transient voltage	$I_O = 0.1 \dots 1.0 \times I_{O_{\max}}$, $V_I = 53\text{V}$ load step = $0.5 \times I_{O_{\max}}$ $di/dt = 5\text{A}/\mu\text{s}$			± 350		mV
T_{coeff}	Temperature coefficient	$I_O = I_{O_{\max}}$, $T_C < T_{C_{\max}}$		0	± 0.011	± 0.25	mV/ $^\circ\text{C}$
t_r	Ramp-up time	$I_O = 0.1 \dots 1.0 \times I_{O_{\max}}$ $V_I = 53\text{V}$	$0.1 \dots 0.9 \times V_O$		20		ms
t_s	Start-up time		From V_I connection to $V_O = 0.9 \times V_{O_i}$		25		
I_O	Output current			0		14	A
$P_{O_{\max}}$	Max output power ²⁾	Calculated value		16.8			W
I_{lim}	Current limiting threshold	$T_C < T_{C_{\max}}$			16.5		A
I_{sc}	Short circuit current	$T_C = +25^\circ\text{C}$				20	A
$V_{O_{ac}}$	Output ripple & noise	$I_O = I_{O_{\max}}$	20 Hz...5 MHz		30	60	mV _{p-p}
SVR	Supply Voltage Rejection (ac)	$f = 100\text{Hz}$ sine wave, 1V_{p-p} , $V_I = 53\text{V}$ ($\text{SVR} = 20 \log(1\text{V}_{p-p}/V_{O_{p-p}})$)			70		dB

1) See Operating information.

2) See also Typical Characteristics, Power derating.

Miscellaneous

Characteristics		Conditions		min	typ	max	Unit
η	Efficiency	$I_O = I_{O_{\max}}$, $V_I = 53\text{V}$, $T_C = +25^\circ\text{C}$		82	85		%
P_d	Power dissipation	$I_O = I_{O_{\max}}$, $V_I = 53\text{V}$, $T_C = +25^\circ\text{C}$				3.2	W
f_s	Switching frequency			145	150	165	kHz

Typical Characteristics

PKD 4118 S10D

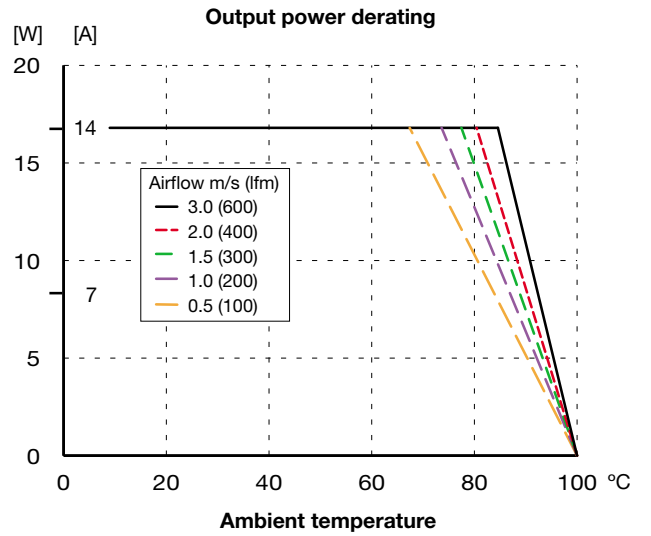
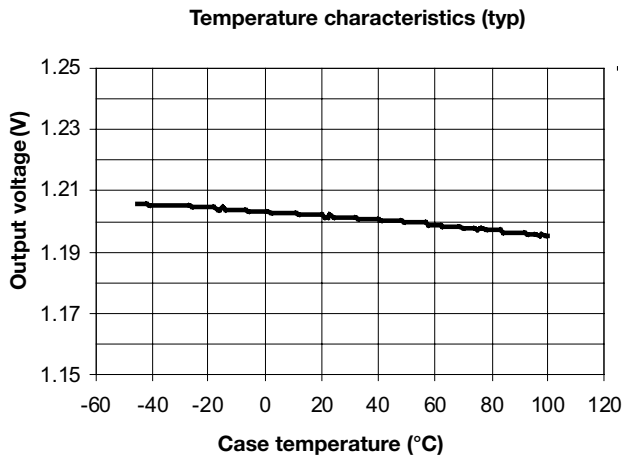
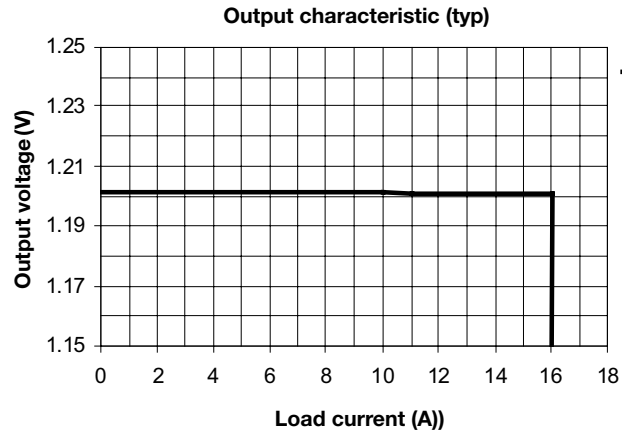
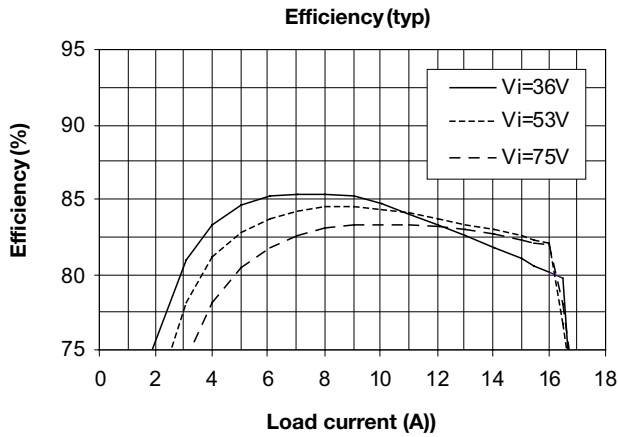

See page 17 for test conditions

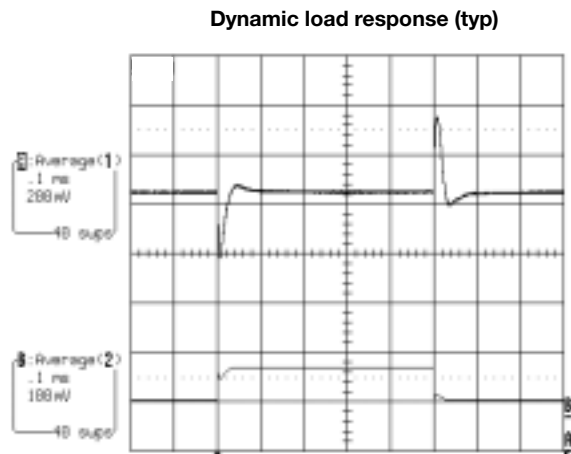

$V_i = 53\text{ V}$
 Load change: $0.25 \times I_{O\text{nom}} \dots 0.75 \times I_{O\text{nom}}$
 $I_{O\text{nom}} = 14\text{ A}$

PKD 4218 SIOA

$T_C = -25 \dots +90^\circ\text{C}$, $V_I = 36 \dots 75\text{V}$ unless otherwise specified.

Output

Characteristics		Conditions		Output 1			Unit	
				min	typ	max		
V_{O_i}	Output voltage initial setting and accuracy	$T_C = +25^\circ\text{C}$, $I_O = I_{O\text{max}}$, $V_I = 53\text{V}$		1.49	1.50	1.51	V	
	Output adjust range ¹⁾			1.35		1.65		
V_O	Output voltage tolerance band	Long term drift included	$I_O = 0.1 \dots 1.0 \times I_{O\text{max}}$	1.45		1.55	V	
	Idling voltage	$I_O = 0$		1.49		1.51		
	Line regulation	$I_O = I_{O\text{max}}$				5		mV
	Load regulation	$I_O = 0.01 \dots 1.0 \times I_{O\text{max}}$, $V_I = 53\text{V}$				5		mV
t_{tr}	Load transient recovery time	$I_O = 0.1 \dots 1.0 \times I_{O\text{max}}$, $V_I = 53\text{V}$ load step = $0.5 \times I_{O\text{max}}$			100		μs	
V_{tr}	Load transient voltage	$I_O = 0.1 \dots 1.0 \times I_{O\text{max}}$, $V_I = 53\text{V}$ load step = $0.5 \times I_{O\text{max}}$ $di/dt = 5\text{A}/\mu\text{s}$			± 350		mV	
T_{coeff}	Temperature coefficient	$I_O = I_{O\text{max}}$, $T_C < T_{C\text{max}}$		0	± 0.025	± 0.25	mV/ $^\circ\text{C}$	
t_r	Ramp-up time	$I_O = 0.1 \dots 1.0 \times I_{O\text{max}}$ $V_I = 53\text{V}$	$0.1 \dots 0.9 \times V_O$		20		ms	
t_s	Start-up time		From V_I connection to $V_O = 0.9 \times V_{O_i}$		25			
I_O	Output current			0		14	A	
$P_{O\text{max}}$	Max output power ²⁾	Calculated value		21			W	
I_{lim}	Current limiting threshold	$T_C < T_{C\text{max}}$			16.5		A	
I_{sc}	Short circuit current	$T_C = +25^\circ\text{C}$				20	A	
$V_{O\text{ac}}$	Output ripple & noise	$I_O = I_{O\text{max}}$	20 Hz...5 MHz		30	60	mV _{p-p}	
SVR	Supply Voltage Rejection (ac)	$f = 100\text{Hz}$ sine wave, 1V_{p-p} , $V_I = 53\text{V}$ ($\text{SVR} = 20 \log(1\text{V}_{p-p}/V_{O\text{p-p}})$)			70		dB	

1) See Operating information.

2) See also Typical Characteristics, Power derating.

Miscellaneous

Characteristics		Conditions	min	typ	max	Unit
η	Efficiency	$I_O = I_{O\text{max}}$, $V_I = 53\text{V}$, $T_C = +25^\circ\text{C}$	85	86		%
P_d	Power dissipation	$I_O = I_{O\text{max}}$, $V_I = 53\text{V}$, $T_C = +25^\circ\text{C}$			3.7	W
f_s	Switching frequency		165	170	175	kHz

Typical Characteristics

PKD 4218 SIOA

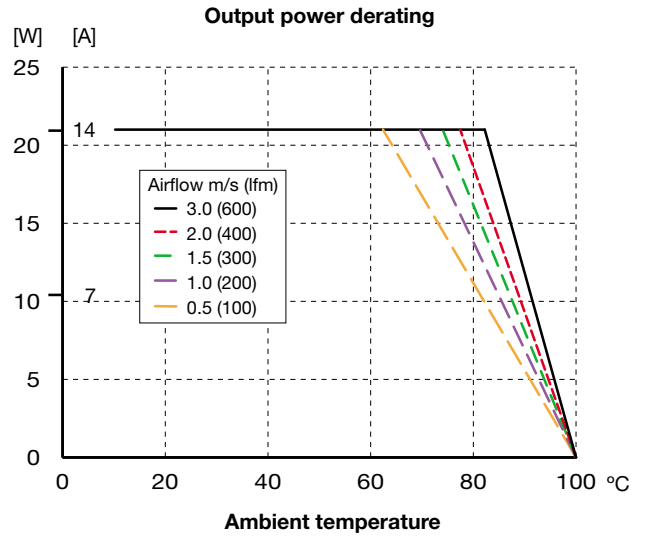
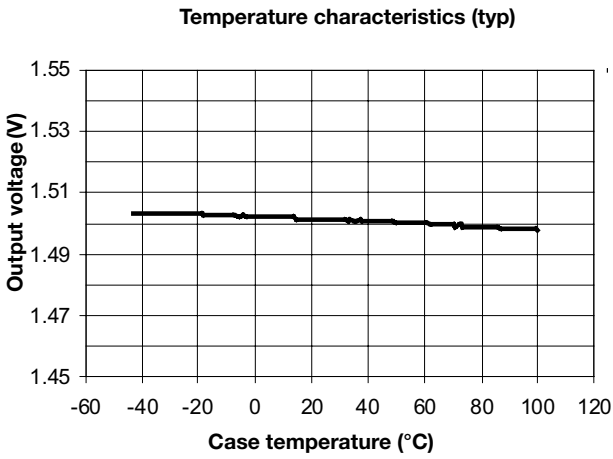
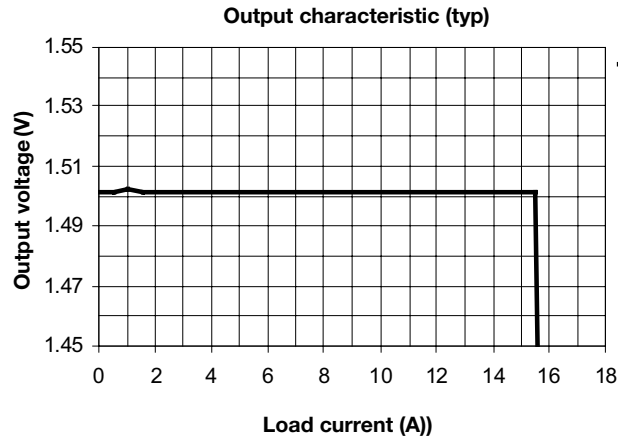
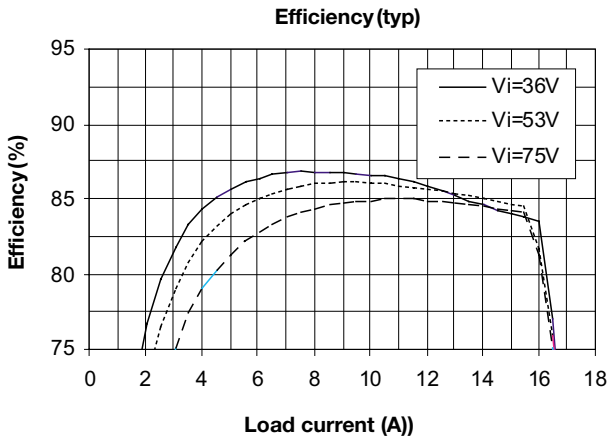

See page 17 for test conditions

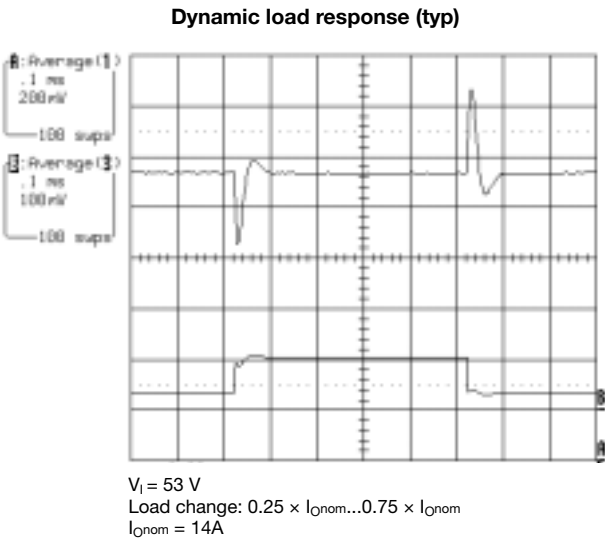

PKD 4218 SI

$T_C = -25...+90^\circ\text{C}$, $V_I = 36 \dots 75\text{V}$ unless otherwise specified.

Output

Characteristics		Conditions		Output 1			Unit
				min	typ	max	
V_{O_i}	Output voltage initial setting and accuracy	$T_C = +25^\circ\text{C}$, $I_O = I_{O_{\max}}$, $V_I = 53\text{V}$		1.79	1.80	1.81	V
	Output adjust range ¹⁾			1.82		1.98	
V_O	Output voltage tolerance band	Long term drift included	$I_O = 0.1 \dots 1.0 \times I_{O_{\max}}$	1.75		1.85	V
	Idling voltage	$I_O = 0$		1.75		1.85	
	Line regulation	$I_O = I_{O_{\max}}$				5	mV
	Load regulation	$I_O = 0.01 \dots 1.0 \times I_{O_{\max}}$, $V_I = 53\text{V}$				5	mV
t_{tr}	Load transient recovery time	$I_O = 0.1 \dots 1.0 \times I_{O_{\max}}$, $V_I = 53\text{V}$ load step = $0.5 \times I_{O_{\max}}$			100		μs
V_{tr}	Load transient voltage	$I_O = 0.1 \dots 1.0 \times I_{O_{\max}}$, $V_I = 53\text{V}$ load step = $0.5 \times I_{O_{\max}}$ $di/dt = 5\text{A}/\mu\text{s}$			± 350		mV
T_{coeff}	Temperature coefficient	$I_O = I_{O_{\max}}$, $T_C < T_{C_{\max}}$		0	± 0.025	± 0.25	mV/ $^\circ\text{C}$
t_r	Ramp-up time	$I_O = 0.1 \dots 1.0 \times I_{O_{\max}}$ $V_I = 53\text{V}$	$0.1 \dots 0.9 \times V_O$		20		ms
t_s	Start-up time		From V_I connection to $V_O = 0.9 \times V_{O_i}$		25		
I_O	Output current			0		14	A
$P_{O_{\max}}$	Max output power ²⁾	Calculated value		25.2			W
I_{lim}	Current limiting threshold	$T_C < T_{C_{\max}}$			16.5		A
I_{sc}	Short circuit current	$T_C = +25^\circ\text{C}$				20	A
$V_{O_{ac}}$	Output ripple & noise	$I_O = I_{O_{\max}}$	20 Hz...5 MHz		30	60	mV _{p-p}
SVR	Supply Voltage Rejection (ac)	$f = 100\text{Hz}$ sine wave, $1 V_{p-p}$, $V_I = 53\text{V}$ ($\text{SVR} = 20 \log(1 V_{p-p}/V_{O_{p-p}})$)			70		dB

1) See Operating information.

2) See also Typical Characteristics, Power derating.

Miscellaneous

Characteristics		Conditions		min	typ	max	Unit
η	Efficiency	$I_O = I_{O_{\max}}$, $V_I = 53\text{V}$, $T_C = +25^\circ\text{C}$		84	86.5		%
P_d	Power dissipation	$I_O = I_{O_{\max}}$, $V_I = 53\text{V}$, $T_C = +25^\circ\text{C}$				4.8	W
f_s	Switching frequency			195	200	205	kHz

Typical Characteristics

PKD 4218 SI

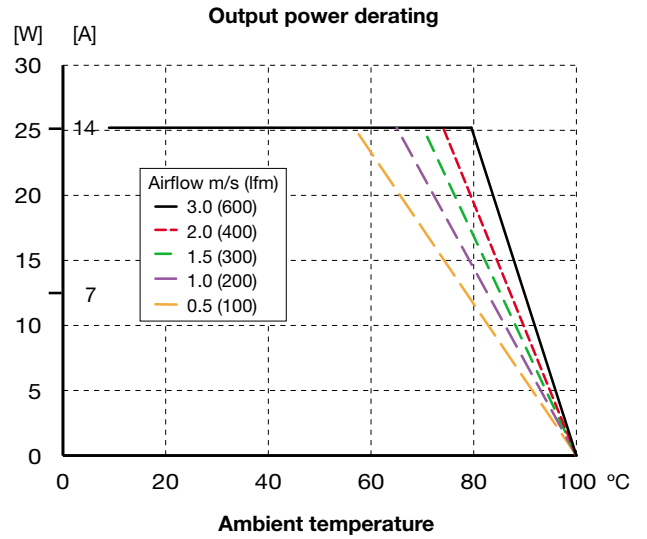
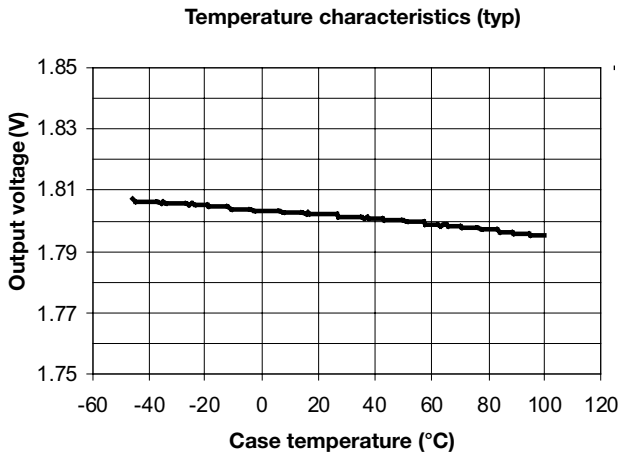
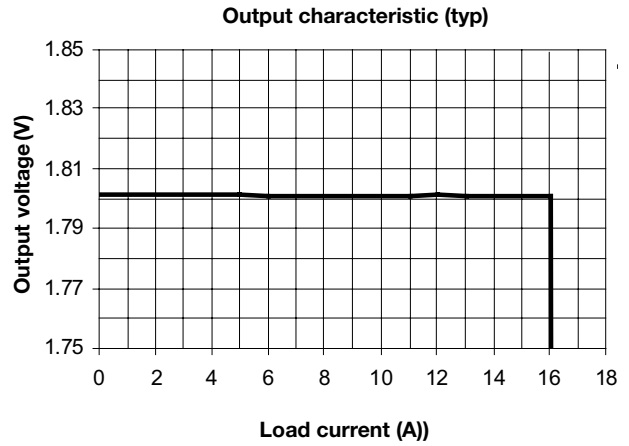
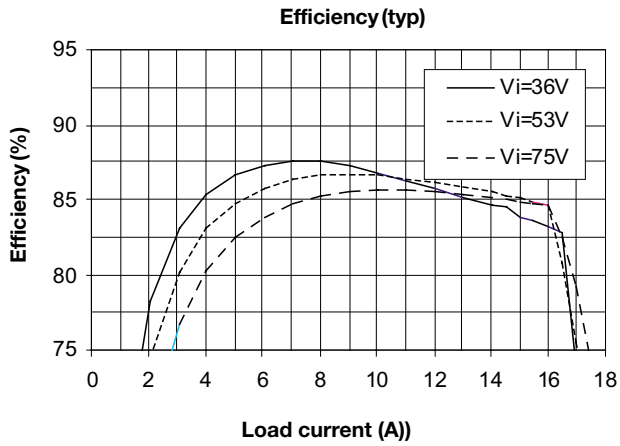

See page 17 for test conditions

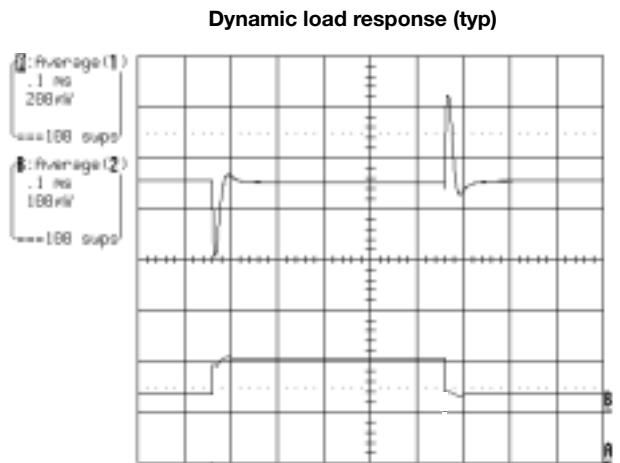

$V_i = 53\text{ V}$
 Load change: $0.25 \times I_{O\text{nom}} \dots 0.75 \times I_{O\text{nom}}$
 $I_{O\text{nom}} = 14\text{ A}$

PKD 4319 SI

$T_C = -25 \dots +90^\circ\text{C}$, $V_I = 36 \dots 75\text{V}$ unless otherwise specified.

Output

Characteristics		Conditions		Output 1			Unit
				min	typ	max	
V_{O_i}	Output voltage initial setting and accuracy	$T_C = +25^\circ\text{C}$, $I_O = I_{O\text{max}}$, $V_I = 53\text{V}$		2.48	2.50	2.52	V
	Output adjust range ¹⁾			2.25		2.75	
V_O	Output voltage tolerance band	Long term drift included	$I_O = 0.1 \dots 1.0 \times I_{O\text{max}}$	2.45		2.55	V
	Idling voltage	$I_O = 0$		2.45		2.55	
	Line regulation	$I_O = I_{O\text{max}}$				5	mV
	Load regulation	$I_O = 0.01 \dots 1.0 \times I_{O\text{max}}$, $V_I = 53\text{V}$				5	mV
t_{tr}	Load transient recovery time	$I_O = 0.1 \dots 1.0 \times I_{O\text{max}}$, $V_I = 53\text{V}$ load step = $0.5 \times I_{O\text{max}}$			100		μs
V_{tr}	Load transient voltage	$I_O = 0.1 \dots 1.0 \times I_{O\text{max}}$, $V_I = 53\text{V}$ load step = $0.5 \times I_{O\text{max}}$ $di/dt = 5\text{A}/\mu\text{s}$			± 350		mV
T_{coeff}	Temperature coefficient	$I_O = I_{O\text{max}}$, $T_C < T_{C\text{max}}$		0	± 0.025	± 0.25	mV/ $^\circ\text{C}$
t_r	Ramp-up time	$I_O = 0.1 \dots 1.0 \times I_{O\text{max}}$ $V_I = 53\text{V}$	$0.1 \dots 0.9 \times V_O$		25		ms
t_s	Start-up time		From V_I connection to $V_O = 0.9 \times V_{O_i}$		30		
I_O	Output current			0		12	A
$P_{O\text{max}}$	Max output power ²⁾	Calculated value		30			W
I_{lim}	Current limiting threshold	$T_C < T_{C\text{max}}$			14		A
I_{sc}	Short circuit current	$T_C = +25^\circ\text{C}$				19	A
$V_{O\text{ac}}$	Output ripple & noise	$I_O = I_{O\text{max}}$	20 Hz...5 MHz		30	60	mV _{p-p}
SVR	Supply Voltage Rejection (ac)	$f = 100\text{Hz}$ sine wave, $1 V_{p-p}$, $V_I = 53\text{V}$ ($\text{SVR} = 20 \log(1 V_{p-p}/V_{O\text{p-p}})$)			70		dB

1) See Operating information.

2) See also Typical Characteristics, Power derating.

Miscellaneous

Characteristics		Conditions	min	typ	max	Unit
η	Efficiency	$I_O = I_{O\text{max}}$, $V_I = 53\text{V}$, $T_C = +25^\circ\text{C}$	87	88		%
P_d	Power dissipation	$I_O = I_{O\text{max}}$, $V_I = 53\text{V}$, $T_C = +25^\circ\text{C}$			4.5	W
f_s	Switching frequency		145	150	155	kHz

Typical Characteristics

PKD 4319 SI

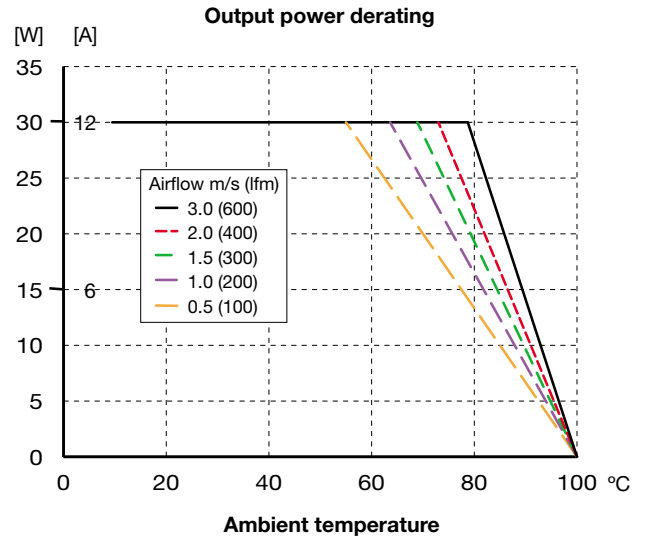
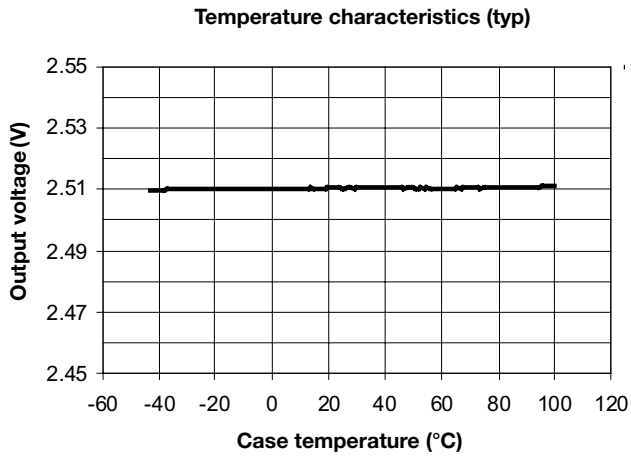
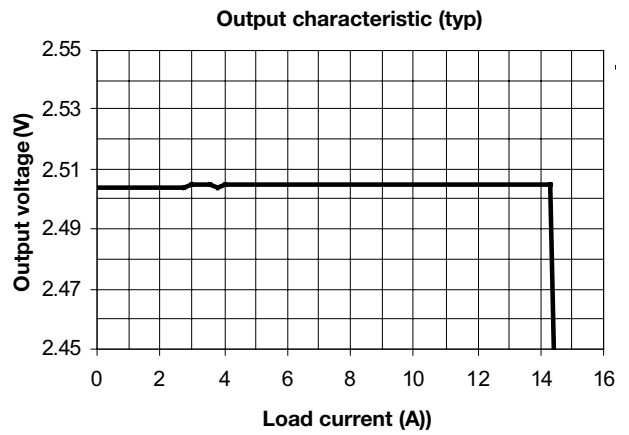
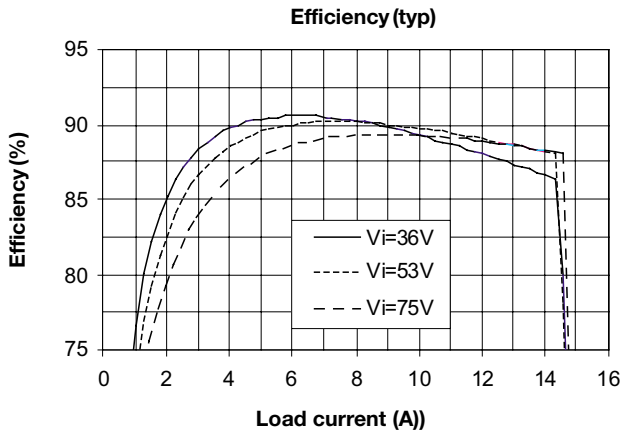

See page 17 for test conditions

Dynamic load response (typ)

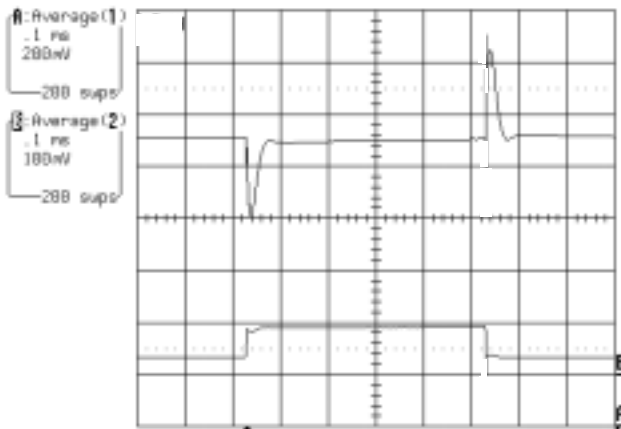

$V_i = 53\text{ V}$
 Load change: $0.25 \times I_{Onom} \dots 0.75 \times I_{Onom}$
 $I_{Onom} = 12\text{ A}$

PKD 4210 SI

$T_C = -25 \dots +90^\circ\text{C}$, $V_I = 36 \dots 75\text{V}$ unless otherwise specified.

Output

Characteristics		Conditions		Output 1			Unit
				min	typ	max	
V_{O_i}	Output voltage initial setting and accuracy	$T_C = +25^\circ\text{C}$, $I_O = I_{O_{\max}}$, $V_I = 53\text{V}$		3.28	3.30	3.32	V
	Output adjust range ¹⁾			3.0		3.5	
V_O	Output voltage tolerance band	Long term drift included	$I_O = 0.1 \dots 1.0 \times I_{O_{\max}}$	3.25		3.35	V
	Idling voltage	$I_O = 0$		3.25		3.35	
	Line regulation	$I_O = I_{O_{\max}}$				5	mV
	Load regulation	$I_O = 0.01 \dots 1.0 \times I_{O_{\max}}$, $V_I = 53\text{V}$				5	mV
t_{tr}	Load transient recovery time	$I_O = 0.1 \dots 1.0 \times I_{O_{\max}}$, $V_I = 53\text{V}$ load step = $0.5 \times I_{O_{\max}}$			100		μs
V_{tr}	Load transient voltage	$I_O = 0.1 \dots 1.0 \times I_{O_{\max}}$, $V_I = 53\text{V}$ load step = $0.5 \times I_{O_{\max}}$ $di/dt = 5\text{A}/\mu\text{s}$			± 300		mV
T_{coeff}	Temperature coefficient	$I_O = I_{O_{\max}}$, $T_C < T_{C_{\max}}$		0	± 0.05	± 0.50	mV/ $^\circ\text{C}$
t_r	Ramp-up time	$I_O = 0.1 \dots 1.0 \times I_{O_{\max}}$ $V_I = 53\text{V}$	$0.1 \dots 0.9 \times V_O$		20		ms
t_s	Start-up time		From V_I connection to $V_O = 0.9 \times V_{O_i}$		25		
I_O	Output current			0		8	A
$P_{O_{\max}}$	Max output power ²⁾	Calculated value		26.5			W
I_{lim}	Current limiting threshold	$T_C < T_{C_{\max}}$			10.5		A
I_{sc}	Short circuit current	$T_C = +25^\circ\text{C}$				16	A
$V_{O_{\text{ac}}}$	Output ripple & noise	$I_O = I_{O_{\max}}$	20 Hz ... 5 MHz		50	100	mV _{p-p}
SVR	Supply Voltage Rejection (ac)	$f = 100\text{Hz}$ sine wave, $1 V_{p-p}$, $V_I = 53\text{V}$ ($\text{SVR} = 20 \log(1 V_{p-p}/V_{O_{p-p}})$)			70		dB

1) See Operating information.

2) See also Typical Characteristics, Power derating.

Miscellaneous

Characteristics		Conditions	min	typ	max	Unit
η	Efficiency	$I_O = I_{O_{\max}}$, $V_I = 53\text{V}$, $T_C = +25^\circ\text{C}$	88	90		%
P_d	Power dissipation	$I_O = I_{O_{\max}}$, $V_I = 53\text{V}$, $T_C = +25^\circ\text{C}$			3.6	W
f_s	Switching frequency		190	200	210	kHz

Typical Characteristics

PKD 4210 SI

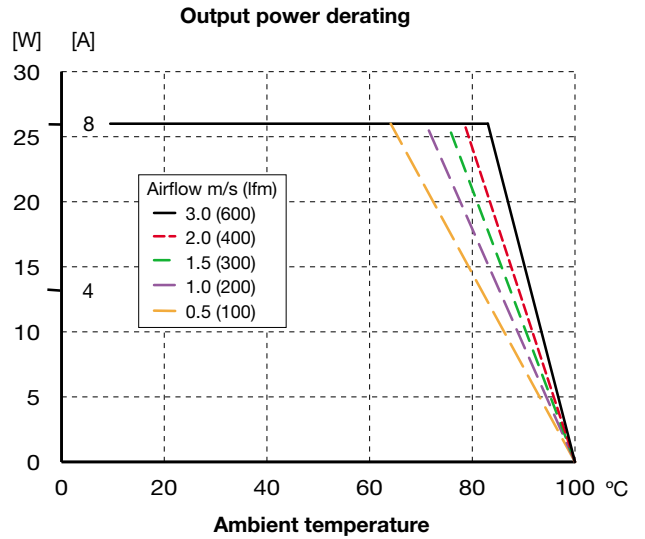
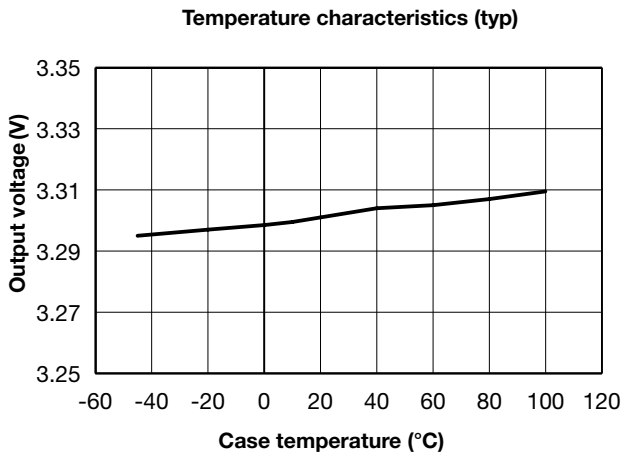
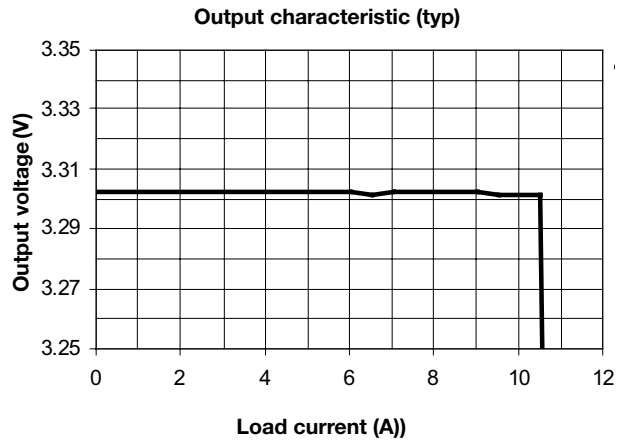
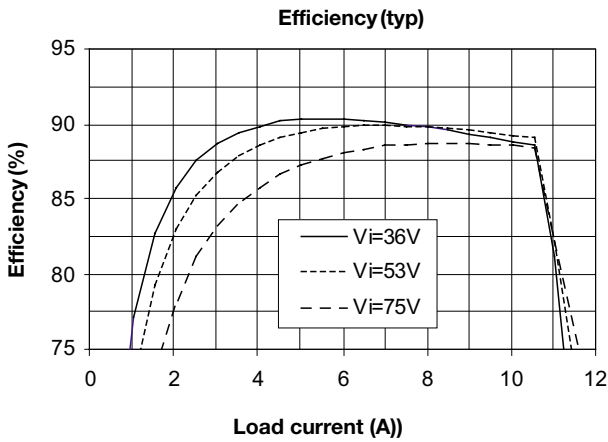

See page 17 for test conditions

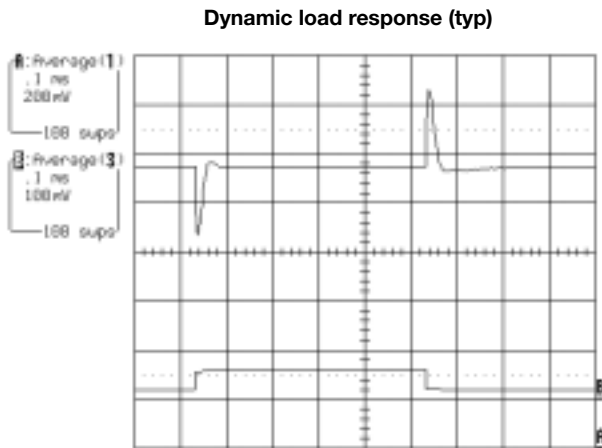

$V_i = 53\text{ V}$
 Load change: $0.25 \times I_{O\text{nom}} \dots 0.75 \times I_{O\text{nom}}$
 $I_{O\text{nom}} = 8\text{ A}$

PKD 4311 SI

$T_C = -25...+90^{\circ}\text{C}$, $V_I = 36 \dots 75\text{V}$ unless otherwise specified.

Output

Characteristics		Conditions		Output 1			Unit
				min	typ	max	
V_{O_i}	Output voltage initial setting and accuracy	$T_C = +25^{\circ}\text{C}$, $I_O = I_{O\text{max}}$, $V_I = 53\text{V}$		4.97	5.00	5.03	V
	Output adjust range ¹⁾			4.5		5.5	
V_O	Output voltage tolerance band	Long term drift included	$I_O = 0.1 \dots 1.0 \times I_{O\text{max}}$	4.92		5.08	V
	Idling voltage	$I_O = 0$		4.92		5.08	
	Line regulation	$I_O = I_{O\text{max}}$				5	mV
	Load regulation	$I_O = 0.01 \dots 1.0 \times I_{O\text{max}}$, $V_I = 53\text{V}$				5	mV
t_{tr}	Load transient recovery time	$I_O = 0.1 \dots 1.0 \times I_{O\text{max}}$, $V_I = 53\text{V}$ load step = $0.5 \times I_{O\text{max}}$			100		μs
V_{tr}	Load transient voltage	$I_O = 0.1 \dots 1.0 \times I_{O\text{max}}$, $V_I = 53\text{V}$ load step = $0.5 \times I_{O\text{max}}$ $dl / dt = 5\text{A} / \mu\text{s}$			± 300		mV
T_{coeff}	Temperature coefficient	$I_O = I_{O\text{max}}$, $T_C < T_{C\text{max}}$		0	± 0.3	± 0.8	mV/ $^{\circ}\text{C}$
t_r	Ramp-up time	$I_O = 0.1 \dots 1.0 \times I_{O\text{max}}$ $V_I = 53\text{V}$	$0.1 \dots 0.9 \times V_O$		22		ms
t_s	Start-up time		From V_I connection to $V_O = 0.9 \times V_{O_i}$		28		
I_O	Output current			0		6	A
$P_{O\text{max}}$	Max output power ²⁾	Calculated value		30			W
I_{lim}	Current limiting threshold	$T_C < T_{C\text{max}}$			7.5		A
I_{sc}	Short circuit current	$T_C = +25^{\circ}\text{C}$				10	A
$V_{O\text{ac}}$	Output ripple & noise	$I_O = I_{O\text{max}}$	20 Hz...5 MHz		80	120	mV _{p-p}
SVR	Supply Voltage Rejection (ac)	$f = 100\text{Hz}$ sine wave, $1 V_{p-p}$, $V_I = 53\text{V}$ ($\text{SVR} = 20 \log(1 V_{p-p} / V_{O\text{p-p}})$)			70		dB

1) See Operating information.

2) See also Typical Characteristics, Power derating.

Miscellaneous

Characteristics		Conditions	min	typ	max	Unit
η	Efficiency	$I_O = I_{O\text{max}}$, $V_I = 53\text{V}$, $T_C = +25^{\circ}\text{C}$	88	90		%
P_d	Power dissipation	$I_O = I_{O\text{max}}$, $V_I = 53\text{V}$, $T_C = +25^{\circ}\text{C}$			4	W
f_s	Switching frequency		190	200	210	kHz

Typical Characteristics

PKD 4311 SI

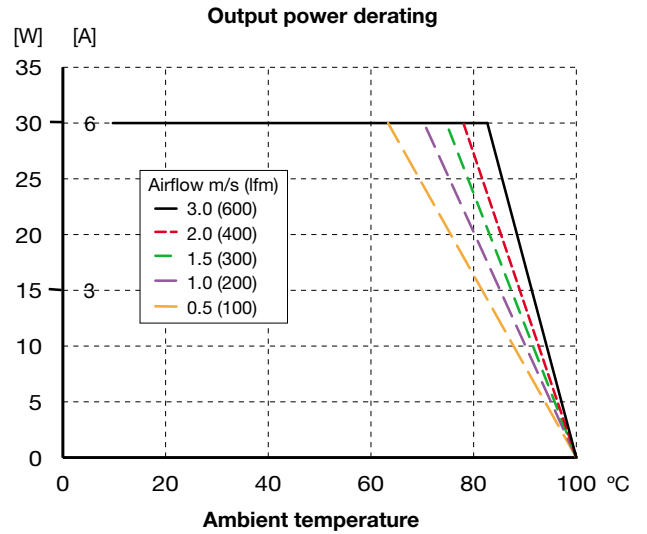
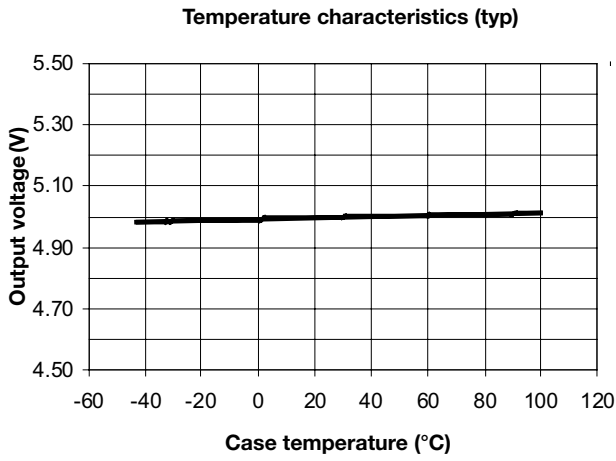
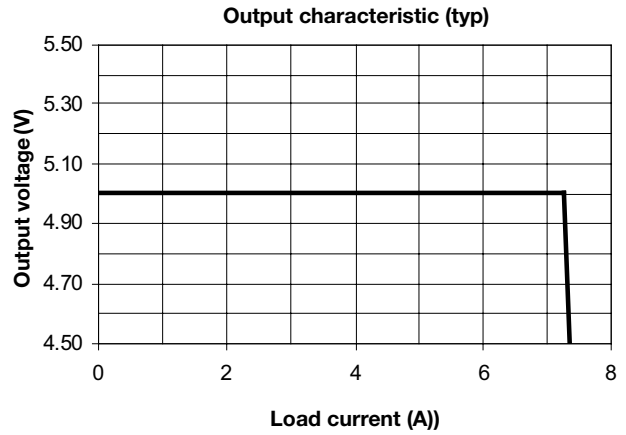
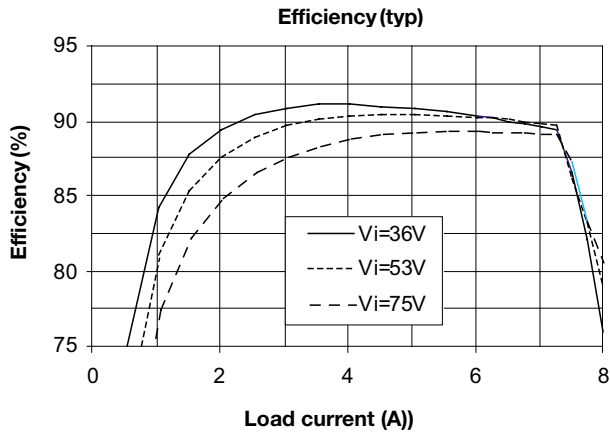

Dynamic load response (typ)

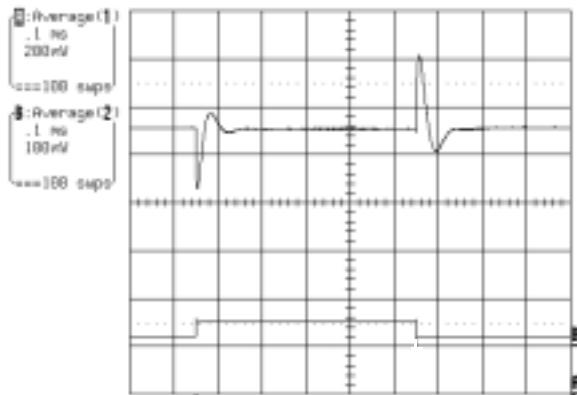

Vi = 53 V
 Load change: $0.25 \times I_{O\text{nom}} \dots 0.75 \times I_{O\text{nom}}$
 $I_{O\text{nom}} = 6\text{A}$

See page 17 for test conditions

EMC Specifications

The conducted EMI measurement was performed using a module placed directly on the test bench.

The fundamental switching frequency is $200\text{kHz} \pm 5\%$ for PKD 4210 SI @ $V_I = 53\text{V}$, $I_O = (0.1 \dots 1.0) \times I_{Omax}$.

Conducted EMI Input terminal value (typ)

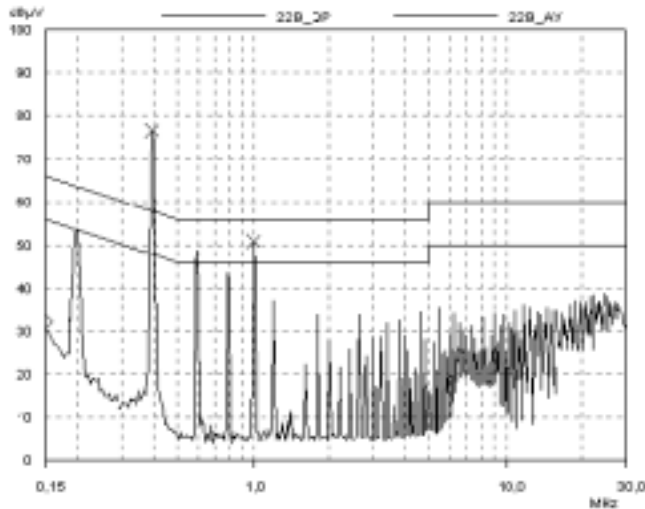

PKD 4210 without filter.

External filter (class B)

Required external input filter in order to meet class B in EN 55022, CISPR 22 and FCC part 15J.

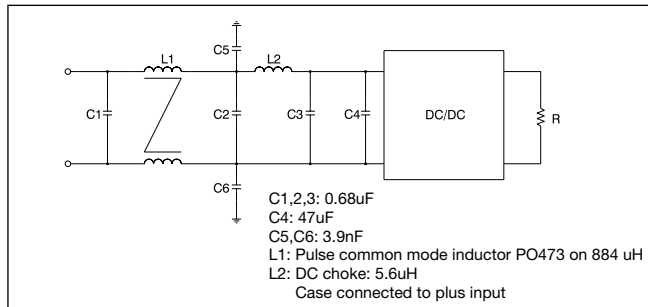

The capacitors are ceramic type. Low ESR is critical for achieving these results.

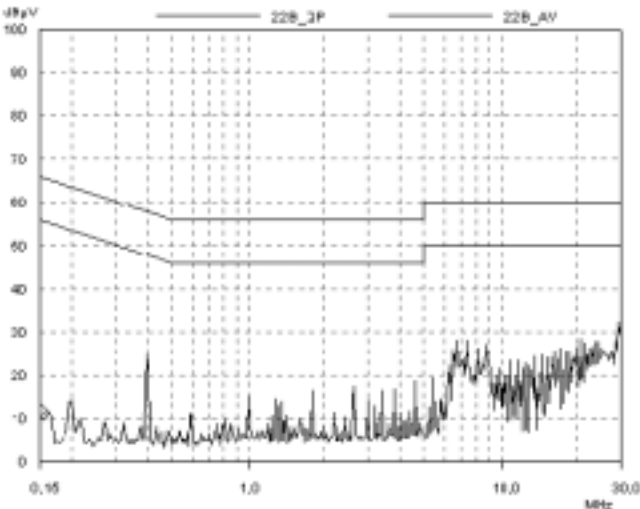

PKD 4210 with filter.

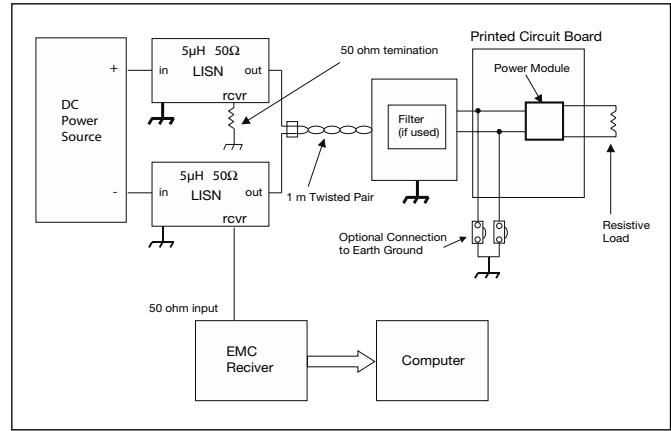

Test set-up.

Radiated susceptibility (EMS)

(Electro-Magnetic Fields)

Radiated EMS is measured according to test methods in EN/IEC Standard 61000-4-3. No deviation outside the V_O tolerance band will occur under the following conditions:
 Frequency range Voltage level
 $30 \dots 990\ \text{MHz } 10\text{V/m}$

ESD

Electro Static Discharge is tested according to EN 61000-4-2.

No destruction will occur if the following voltage levels are applied to any of the terminal pins:
 Direct discharge of max 8kV.

EFT

According to EN 61000-4-4.

Test signal: 1-2-3-4kV

The module will work properly after the transients.

A voltage dip up to 250mV may occur during transients.

Output ripple & noise (V_{Oac})

Output ripple is measured as the peak to peak voltage of the fundamental switching frequency

Operating information

Maximum capacitive load

The PKD series of converters has no limitation of maximum connected capacitance on the output. Capacitance on the output will affect the ramp-up and the start-up time.

Parallel operation

For safe parallel operation a low voltage drop diode must be connected in series with each output.

Series operation

If sense pins are directly connected to output on each module it is possible to connect modules in series.

Case to ambient thermal resistance

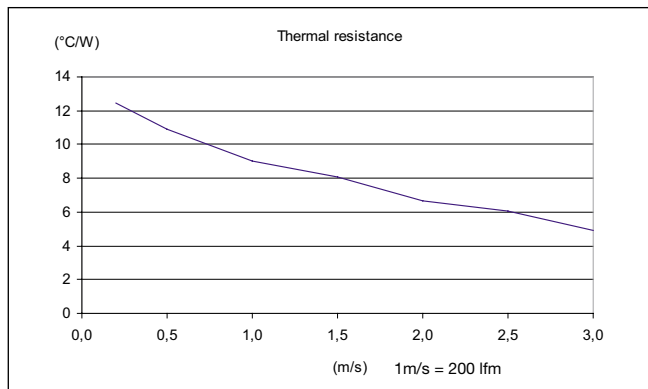

Tested in windtunnel with a cross section of 305×305mm mounted on a 2 layer PCB with a size of 230×160mm. Airspeed measured at module.

Calculation of temperature increase of case

1. First we need to know the powerloss by using the formula:

$$\left(\frac{1}{\eta} - 1\right) \times \text{output power} = \text{losses.}$$

η = efficiency of converter. E.g 89% = 0.89

2. Then we take the powerlosses × thermal resistance at the air speed in your system. This gives the temperature increase.

3. Max allowed ambient temperature, is max allowed case temperature (100°C) – temperature increase.

E.g PKD 4210 at 1m/s:

A. $\left(\frac{1}{0.89} - 1\right) \times 26.5W = 3.275W$

B. $3.275W \times 9.0^{\circ}C/W = 29.5^{\circ}C$

C. $100^{\circ}C - 29.5^{\circ}C = \text{max ambient temperature is } 70.5^{\circ}C$

The real temperature will be dependent on several factors like PCB size, direction of air flow, air turbulence etc. Please always verify by testing.

Soldering information

The PKD series of DC/DC power modules are manufactured in surface mount technology. Extra precautions must therefore be taken when reflow soldering. Neglecting the soldering information given below may result in permanent damage or significant degradation of power module performance.

The PKD series can be reflow soldered using Natural Convection, Forced Convection Technologies. The high thermal mass of the component and its effect on temperature requires that particular attention be paid to other temperature sensitive components.

Please measure temperatures on pin: 22

Ramp and slope: max 4°C per second.

Low temperature solder ¹⁾

Peak 210-235°C
Min 10 s over 200°C
30-100 s over 183°C

High temperature solder ²⁾

Peak 235-260°C
Min 20 s over 230°C
30-100 s over 221°C

Input and output impedance

Both the source impedance of the power feeding and the load impedance will interact with the impedance of the

DC/DC power module. It is most important to have the ratio between L and C as low as possible, i.e. a low characteristic impedance, both at the input and output, as the power modules have a low energy storage capability. Use an electrolytic capacitor across the input if the source inductance is larger than 10 μH.

The equivalent series resistance of these capacitors together with the capacitance acts as a lossless damping filter. Suitable capacitor values are in the range 10 –100 μF.

Protection and control function

Remote Control pin (RC)

The PKD power modules are offered with either positive or negative logic to turn the converter on or off.

The SI version has positive logic and the converter will turn on if the input voltage is applied with the RC pin open. Turn off is achieved by connecting the RC pin to the minus input. To ensure safe turn off of the SI version the voltage difference between negative input pin (-In) and the remote control pin (RC) shall be less than 0.6V. The converter will restart when this connection is opened.

The SIN version has negative logic and will be off until the RC pin is connected to the minus input.

To turn on the SIN version the voltage between RC pin and minus input should be less than 1V.

To turn off the SIN version the RC pin should be left open, or should be connected to a voltage higher than 4V referenced to minus input. RC is CMOS open drain compatible. Current is less than 1mA and voltage less than 15V.

1) Solder with a melting point approximately 180°C.

2) Solder with a melting point approximately 220°C.

Output voltage adjust (V_{adj})¹⁾

Output voltage, V_O , can be adjusted by using an external resistor. To decrease the output voltage the resistor should be connected between pin 16 and pin 15 (+Sense). To increase the output voltage the resistor should be connected between pin 16 and pin 17 (-Sense).

Please consult our application note AN 108D.

Sense leads¹⁾

All PKD series DC/DC power modules have remote sense that can be used to compensate for moderate amounts of resistance in the distribution system and allow for voltage regulation at the load or other selected point. The remote sense lines will carry a current less than 50mA, and do not need a large cross sectional area. However, the sense lines on a PCB should be located close to a ground trace or ground plane. In a discrete wiring situation, the usage of twisted pair wires or other technique for reducing noise susceptibility is recommended.

The power module will compensate for up to 10% voltage drop between the sensor voltage and the voltage at the power module output pins. If the remote sense is not needed the -Sense should be connected to -Out and +Sense should be connected to +Out.

Over Temperature Protection (OTP)

The PKD DC/DC power modules are protected from thermal over load by an internal over-temperature shutdown circuit. When the case temperature exceeds $+130^{\circ}\text{C} \pm 15^{\circ}\text{C}$ the converter will automatically shut down. The converter will automatically restart when temperature is below $+115^{\circ}\text{C}$.

Layout recommendation

The radiated EMI performance of the power module will be optimized by including a ground plane in the PCB area under the module. This approach will return switching noise to ground as directly as possible, with improvements to both emissions and susceptibility. If one ground trace is used, it should be connected to the input return. Alternatively, two ground traces may be used, with the trace under the input side of the module connected to input return and the trace under the output side of the module connected to the output return. Make sure to use appropriate safety isolation spacing between these two return traces. The use of two traces as described will provide the capability of routing the input noise and output noise back to their respective returns.

¹⁾ When using the output voltage adjust or the sense pins to increase the output voltage, full positive adjust range, can only be guaranteed above 40V input voltage.

Delivery Package Information

Trays

PKD series can be delivered in trays (designated by /B) on request, see figure 1 below. For more information, please contact your local Ericsson sales office.

Specification

Material:	Polypropylene (PP)
Max temperature:	125 °C
Max surface resistance:	10 ⁵ Ω/□
Color:	Black
Capacity:	10 pcs/tray
Stacking pitch:	64,25 mm
Weight:	230g
Min. order quantity:	50 pcs (one box contains 5 full trays)

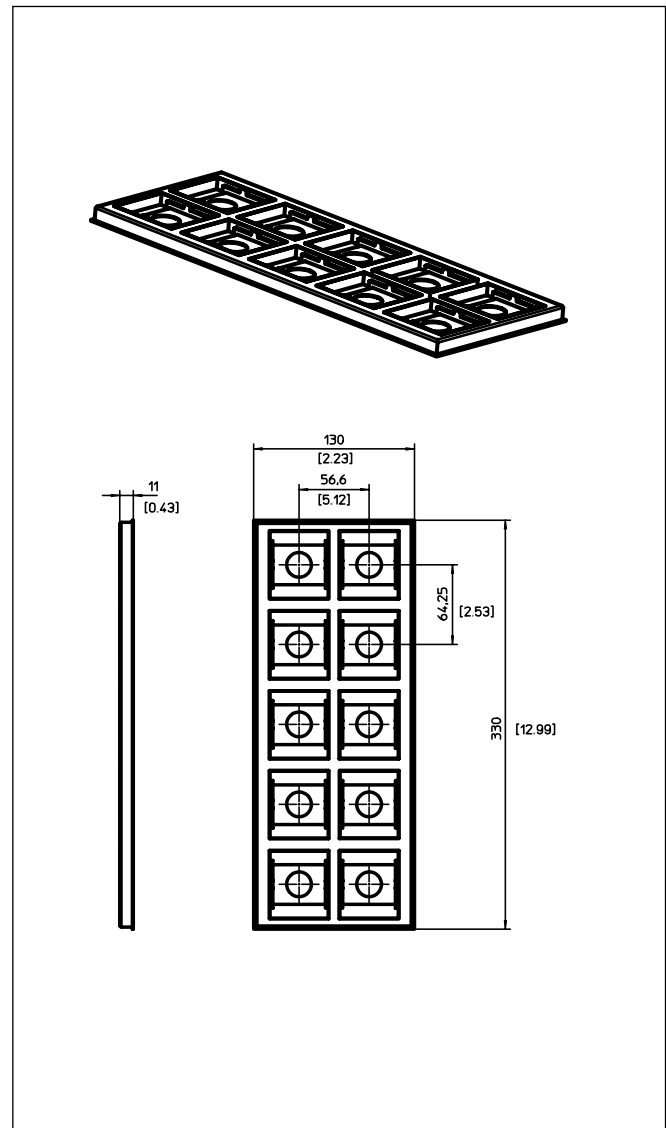

Fig 1.

Tape & Reel

PKD series can be delivered in standard tape & reel package (designated by /C) on request, see figure 2 below. For more information on availability, please contact your local Ericsson sales office.

Specification

Tape material:	Conductive polystyrene (PS)
Tape with:	72 mm
Tape pitch:	54 mm
Max surface resistance:	$10^5 \Omega/\square$
Tape color:	Black
Cover tape color:	Transparent
Reel diameter:	13"
Reel hub diameter:	7"
Reel capacity:	100 pcs/reel
Full reel weight:	Typ. 2.7 kg
Min.order quantity:	200 pcs (one box contains two reels)

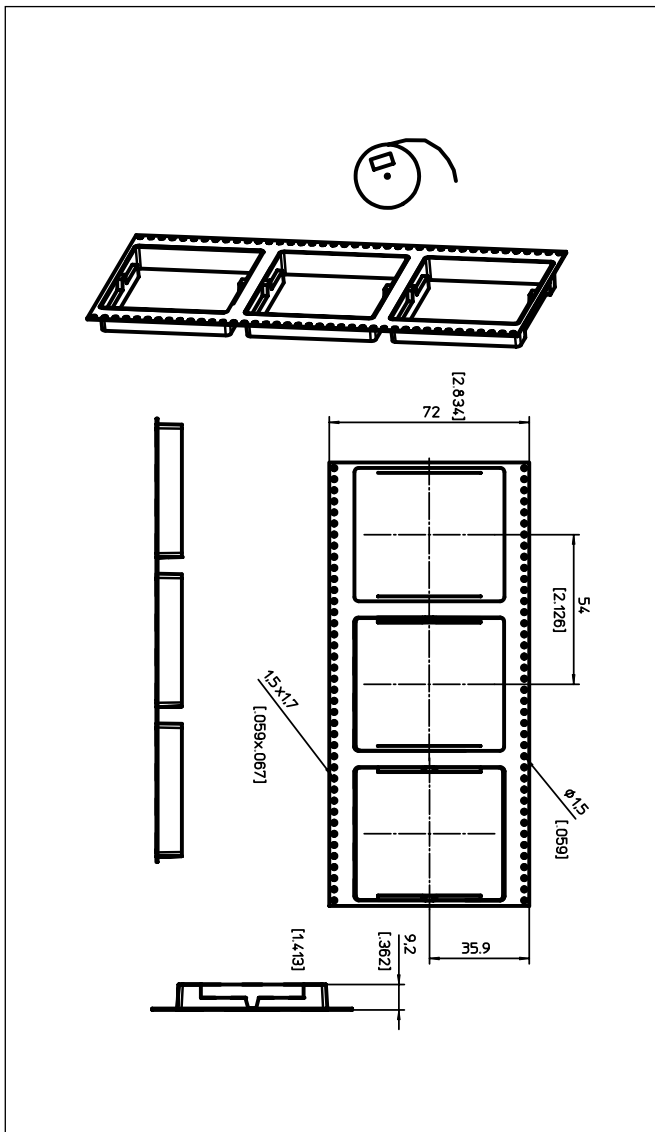

Fig 2.

Quality

Reliability

Mean time between failure (MTBF) is calculated to $>5,100,000$ hours at full output power and a case temperature of $+75^\circ\text{C}$ ($T_A = +40^\circ\text{C}$), using the Ericsson failure rate data system. The Ericsson failure rate data system is based on field failure rates and is continuously updated. The data corresponds to actual failure rates of component used in Information Technology and Telecom equipment in temperature controlled environments ($T_A = -5 \dots +65^\circ\text{C}$). The data is considered to have a confidence level of 90%. For more information see Design Note 002.

Quality statement

The products are designed and manufactured in an industrial environment where quality systems and methods such as ISO 9000, 6σ and SPC, are intensively in use to boost the continuous improvements strategy. Infant mortality or early failures in the products are screened out by a burn-in procedure and an ATE-based final test.

Conservative design rules, design reviews and product qualifications, as well as the high competence of an engaged work force, contribute to the high quality of our products.

Warranty

Ericsson Power Modules warrants to the original purchaser or end user that the products conform to this Data Sheet and are free from material and workmanship defects for a period of five (5) years from the date of manufacture, if the product is used within specified conditions and not modified. In case the product is discontinued, claims will be accepted up to three (3) years from the date of the discontinuation.

For additional details on this limited warranty we refer to Ericsson Power Modules AB's "General Terms and Conditions of Sales", or individual contract documents.

Limitation of liability

Ericsson Power Modules does not make any other warranties, expressed or implied including any warranty of merchantability or fitness for a particular purpose (including, but not limited to, use in life support applications, where malfunctions of product can cause injury to a person's health or life).

Product program

V_i	V_o/I_o max	P_O max	Ordering No.
	Output 1		
48/60 V	1.2 V/14 A	16.8 W	PKD 4118 SIOD
48/60 V	1.5 V/14 A	21 W	PKD 4218 SIOA
48/60 V	1.8 V/14 A	25.2 W	PKD 4218 SI
48/60 V	2.5 V/12 A	30 W	PKD 4319 SI
48/60 V	3.3 V/8 A	26 W	PKD 4210 SI
48/60 V	3.3 V/8 A	26 W	PKD 4210 SIN
48/60 V	5.0 V/6 A	30 W	PKD 4311 SI

SI version has positive logic on remote control pin.
SIN version has negative logic on remote control pin.

Information given in this data sheet is believed to be accurate and reliable. No responsibility is assumed for the consequences of its use nor for any infringement of patents or other rights of third parties which may result from its use. No license is granted by implication or otherwise under any patent or patent rights of Ericsson Power Modules. These products are sold only according to Ericsson Power Modules' general conditions of sale, unless otherwise confirmed in writing. Specifications subject to change without notice.

Ericsson Power Modules

Månskärsvägen 9
SE-141 75 Kungens Kurva, Sweden
Phone: +46 8 568 69620
www.ericsson.com/powermodules

For local sales contacts, please refer to our website
or call: Int. +46 8 568 69620, Fax: +46 8 568 69599

The latest and most complete information can be found on our website

Data Sheet

EN/LZT 146 120 R2B
© Ericsson Power Modules AB, March 2003