

FEATURES

- ◆ Super high dense cell design for low $R_{DS(ON)}$.
- ◆ Rugged and reliable.
- ◆ SOP-8 package.
- ◆ Pb Free.

Product Summary		
V_{DS} (V)	I_D (A)	$R_{DS(ON)}$ (mΩ) Max
20V	6A	32 @ $V_{GS} = 4.0V$
		43 @ $V_{GS} = 2.5V$

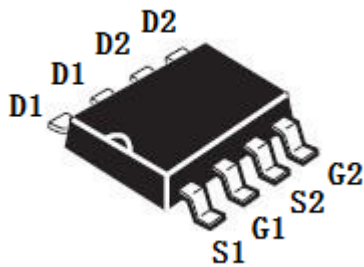

SOP-8

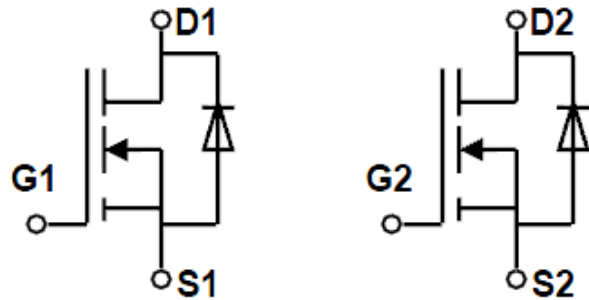

ABSOLUTE MAXIMUM RATINGS (TA = 25 °C unless otherwise noted)

Parameter	Symbol	Limit	Unit
Drain-Source Voltage	V_{DS}	20	V
Gate-Source Voltage	V_{GS}	±10	V
Drain Current-Continuous @ $T_C = 25\text{ C}$	I_D	6	A
-Pulse d^b	I_{DM}	35	A
Drain-Source Diode Forward Current ^a	I_S	1.7	A
Maximum Power Dissipation ^a	P_D	2	W
Operating Junction and Storage Temperature Range	T_J, T_{STG}	-55 to 150	°C

THERMAL CHARACTERISTICS

Thermal Resistance, Junction-to-Ambient ^a	$R_{\theta JA}$	62.5	°C/W
--	-----------------	------	------

ELECTRICAL CHARACTERISTICS (TA = 25 °C unless otherwise noted)

Parameter	Symbol	Condition	Min	Typc	Max	Unit
Drain-Source Breakdown Voltage	BV_{DSS}	$V_{GS}=0V, I_D=250\mu A$	20			V
Zero Gate Voltage Drain Current	I_{DSS}	$V_{DS}=16V, V_{GS}=0V$			1	μA
Gate-Body Leakage	I_{GSS}	$V_{GS}=\pm 10V, V_{DS}=0V$			± 100	nA
Gate Threshold Voltage	$V_{GS(th)}$	$V_{DS}=V_{GS}, I_D=250\mu A$	0.5	0.8	1.5	V
Drain-Source On-State Resistance	$R_{DS(ON)}$	$V_{GS}=4.0V, I_D=6A$		25	32	m Ω
		$V_{GS}=2.5V, I_D=3A$		35	43	
On-State Drain Current	$I_{D(ON)}$	$V_{DS}=5V, V_{GS}=4V$	30			A
Forward Transconductance	g_{FS}	$V_{DS}=5V, I_D=4A$		12		S
Input Capacitance	C_{ISS}	$V_{DS}=8V$		810		pF
Output Capacitance	C_{OSS}	$V_{GS}=0V$		155		
Reverse Transfer Capacitance	C_{RSS}	$f=1.0MHz$		125		
Turn-On Delay Time	$t_{D(ON)}$	$V_{DD}=10V,$ $I_D=1A,$ $V_{GEN}=4.5V,$ $R_{GEN}=10\Omega,$ $R_L=10\Omega$		18		ns
Rise Time	t_r			5		
Turn-Off Delay Time	$t_{D(OFF)}$			44		
Fall Time	t_f			20		
Total Gate Charge	Q_g	$V_{DS}=10V,$ $I_D=4A,$ $V_{GS}=4.5V$		11		nC
Gate-Source Charge	Q_{gs}			3		
Gate-Drain Charge	Q_{gd}			2.5		
Diode Forward Voltage	V_{SD}	$V_{GS}=0V, I_D=1A$		0.8	1.2	V

Notes:

- Surface Mounted on FR4 Board, $t \leq 10$ sec.
- Pulse Test: Pulse Width $\leq 300 \mu s$, Duty Cycle $\leq 2\%$.
- Guaranteed by design, not subject to production testing.

HT9926

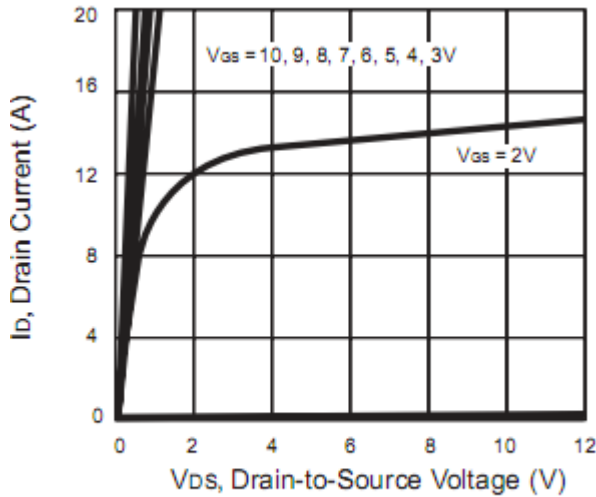

Figure 1. Output Characteristics

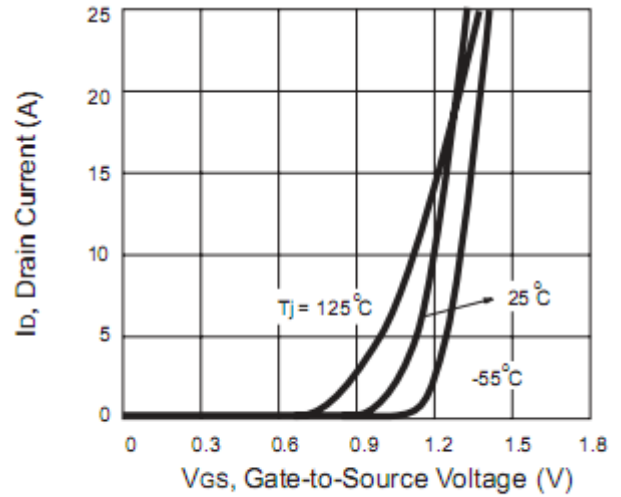

Figure 2. Transfer Characteristics

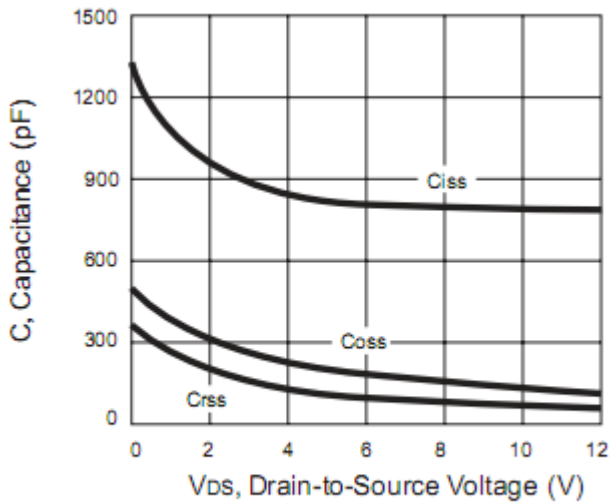

Figure 3. Capacitance

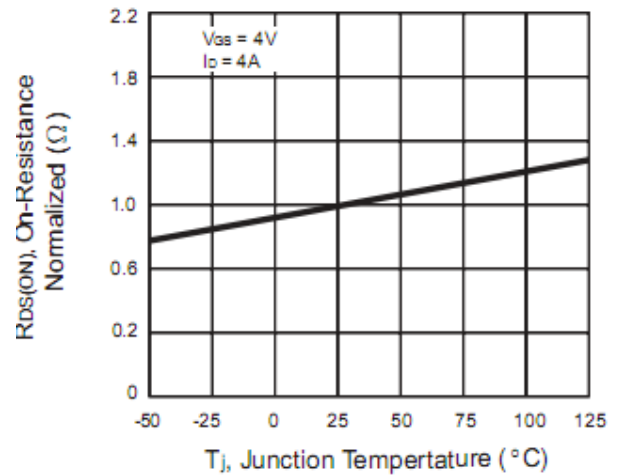

Figure 4. On-Resistance Variation with Temperature

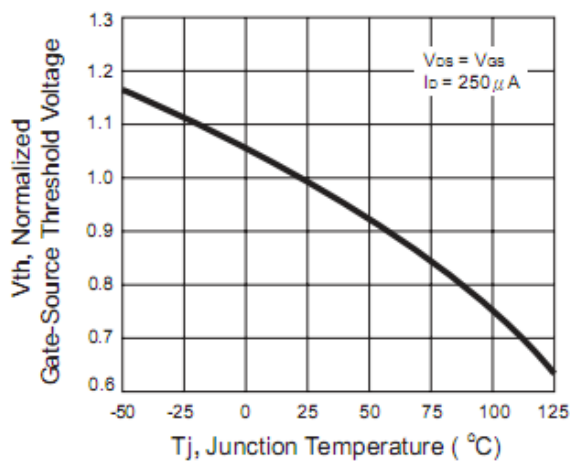

Figure 5. Gate Threshold Variation with Temperature

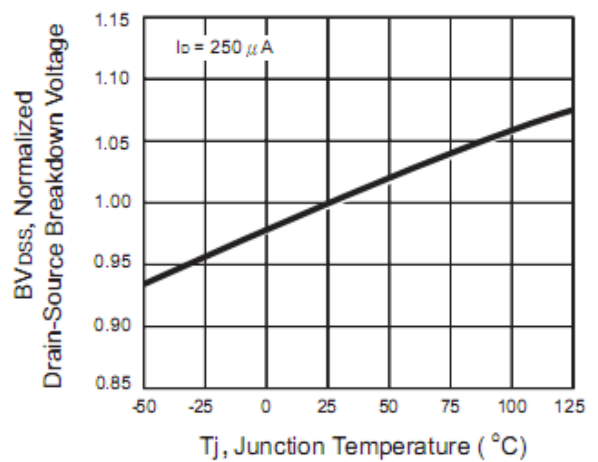

Figure 6. Breakdown Voltage Variation with Temperature

HT9926

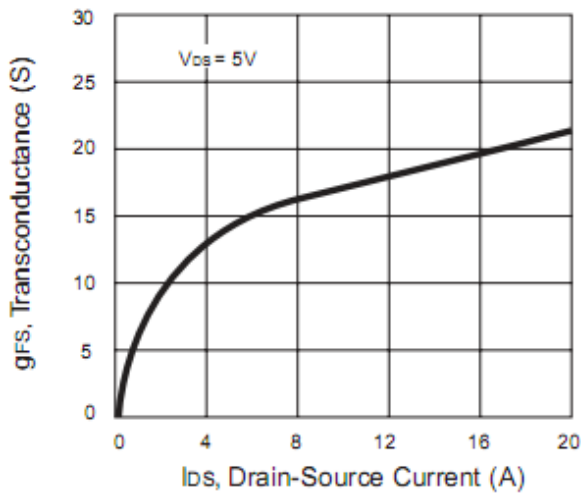

Figure 7. Transconductance Variation with Drain Current

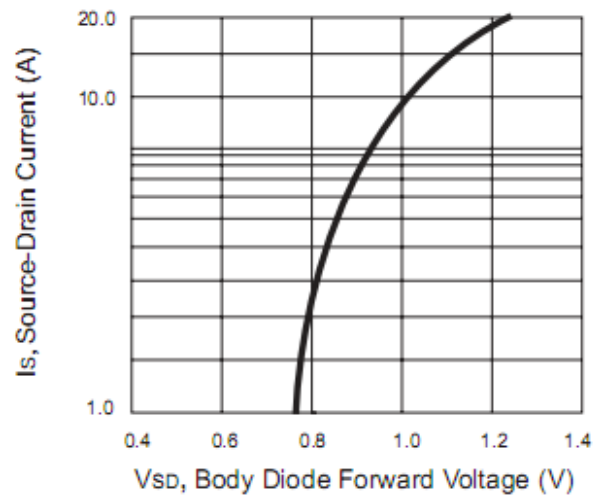

Figure 8. Body Diode Forward Voltage Variation with Source Current

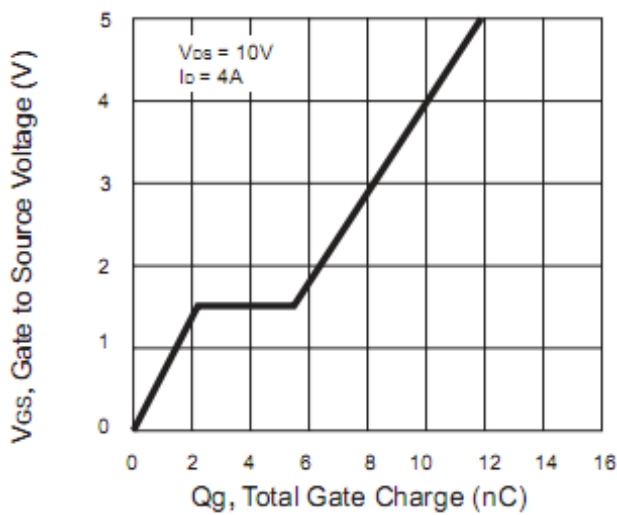

Figure 9. Gate Charge

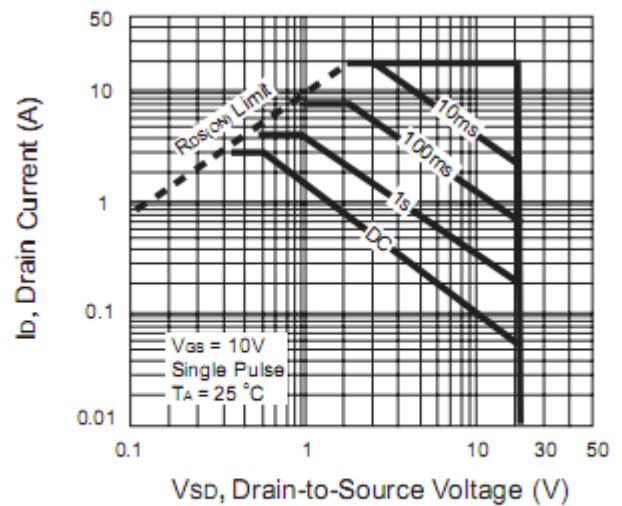

Figure 10. Maximum Safe Operating Area

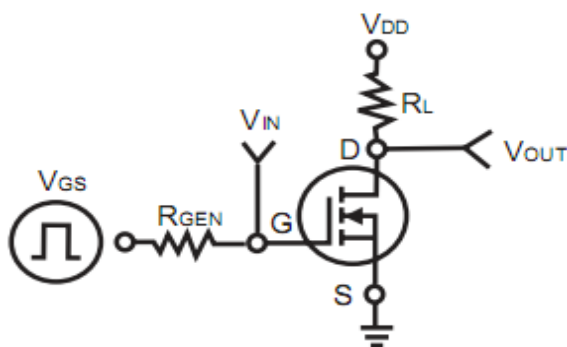

Figure 11. Switching Test Circuit

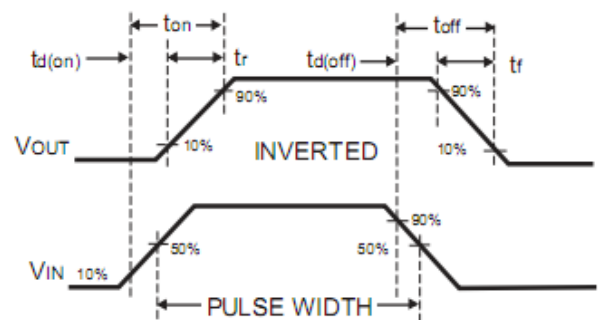

Figure 12. Switching Waveforms

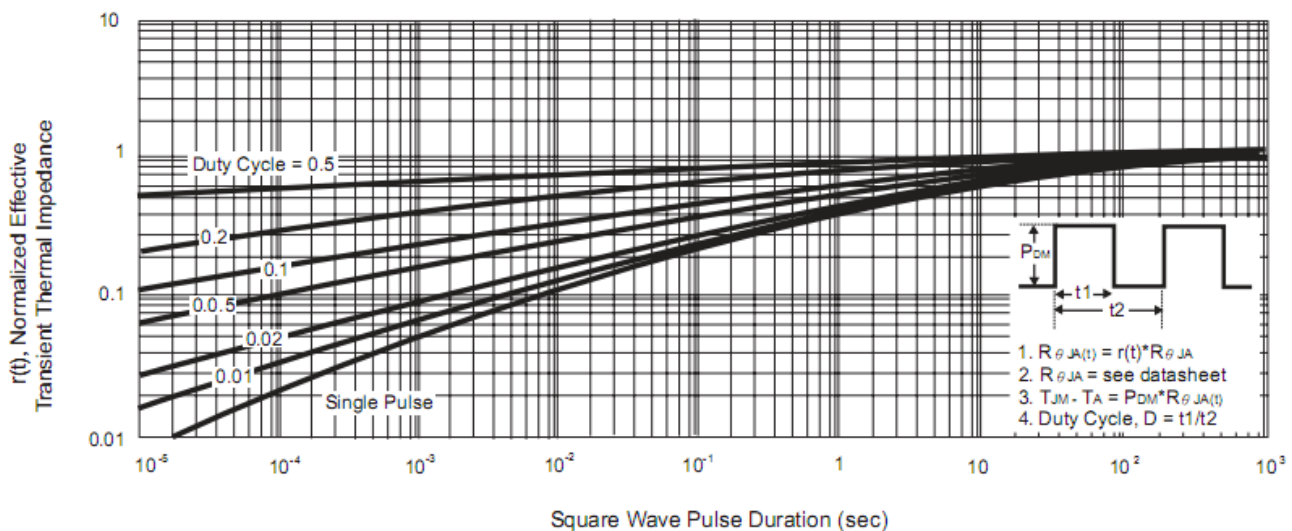

Figure 13. Normalized Thermal Transient Impedance Curve