

256Mb M-die MLC NOR Specification

INFORMATION IN THIS DOCUMENT IS PROVIDED IN RELATION TO SAMSUNG PRODUCTS, AND IS SUBJECT TO CHANGE WITHOUT NOTICE.

NOTHING IN THIS DOCUMENT SHALL BE CONSTRUED AS GRANTING ANY LICENSE, EXPRESS OR IMPLIED, BY ESTOPPEL OR OTHERWISE,

TO ANY INTELLECTUAL PROPERTY RIGHTS IN SAMSUNG PRODUCTS OR TECHNOLOGY. ALL INFORMATION IN THIS DOCUMENT IS PROVIDED

ON AS "AS IS" BASIS WITHOUT GUARANTEE OR WARRANTY OF ANY KIND.

1. For updates or additional information about Samsung products, contact your nearest Samsung office.
2. Samsung products are not intended for use in life support, critical care, medical, safety equipment, or similar applications where Product failure could result in loss of life or personal or physical harm, or any military or defense application, or any governmental procurement to which special terms or provisions may apply.

* Samsung Electronics reserves the right to change products or specification without notice.

Document Title**256M Bit (16M x16) Muxed Burst , Multi Bank MLC NOR Flash Memory**Revision History

<u>Revision No.</u>	<u>History</u>	<u>Draft Date</u>	<u>Remark</u>
0.0	Initial	October 17, 2005	Preliminary
0.1	Revision tCEZ is changed. 20ns==>15ns 44FBGA PKG diagram is added	October 19, 2005	Preliminary
0.2	Package diagram is added (New format)	October 26,2005	Preliminary
0.3	DPD pin assignment is changed D6 ==> C7 AC parameters are changed tBA : 8ns ==> 9ns (@83MHz) tBDH : 1.5ns ==> 3ns (@66Mhz, 83MHz), 2ns (@133Mhz) tOE : 20ns ==> 15ns tRDYA : 8ns ==> 9ns (@83MHz) tRDYS : 4ns (@66Mhz, 83MHz), 1.5ns (@133Mhz) ==> 3ns (@66Mhz, 83MHz), 2ns (@133Mhz) tOER : 20ns ==> 11ns (@66Mhz), 9ns (@83MHz), 6ns (@133Mhz) Active write current 15mA (Typ.), 30mA (Max.) ==> 25mA (Typ.), 40mA (Max.)	November 10,2005	Preliminary
0.4	Correct typo Add Speed characteristic for 108Mhz Sync Burst Read Add Ordering Information for Density ==> 56 : 256Mb for 66/83MHz ==> 57 : 267Mb for 108/133Mhz Add Product Classification Table (Table 1-1) Change tAVDH(AVD Hold Time from CLK) 6ns(@66MHz) ==> 2ns(@66MHz) 5ns(@83MHz) ==> 2ns(@83MHz) Change tAAVDH(Address Hold Time from Rising Edge of AVD) 7ns(@66MHz) ==> 2ns(@66MHz) 5ns(@83MHz) ==> 2ns(@83MHz) Change tCES(CE Setup Time to CLK) 4.5ns(@83/133MHz) ==> 6ns(@83/133MHz) Change tOEZ(Output Disable to High Z 10ns(@66/83MHz) ==> 15ns(@66/83MHz) Add Description and Figure of DPD	December 20,2005	Preliminary
0.5	Correct typo Move address tables to the end of specification Correct note number on Command Sequence table Change t _{GHWL} (Read Recovery Time Before Write) 0ns(typ.) ==> 0ns(min.) Change t _{W_P} (WE Pulse Width) 60ns(typ.) ==> 60ns(min.) Change t _{W_{PH}} (WE Pulse Width High) 40ns(typ.) ==> 40ns(min.)	January 05,2006	Preliminary

<u>Revision No.</u>	<u>History</u>	<u>Draft Date</u>	<u>Remark</u>
0.6	CFI note is added (Max Operation frequency : Data 53H is in 66/83Mhz part	April 04, 2006	Preliminary
1.0	tOEZ value is changed min 15ns to max 15ns Specification is finalized	April 20,2006	
1.1	Active Asynchronous read Current(@1Mhz) is changed 3mA(typ.),5mA(max.) to 8mA(typ.), 10mA(max.) 'In erase/program suspend followed by resume operation, min. 200ns is needed for checking the busy status' is added Frequency information is added to Programmable Wait State at Burst Mode Configuration Register Table. " Asynchronous mode may not support read following four sequential invalid read condition within 200ns." is added	September 08, 2006	
1.2	Correct typo	September 28, 2006	

256M Bit (16M x16) Muxed Burst , Multi Bank MLC NOR Flash Memory

FEATURES

- Single Voltage, 1.7V to 1.95V for Read and Write operations
- Organization
 - 16,777,216 x 16 bit (Word Mode Only)
- Multiplexed Data and Address for reduction of interconnections
 - A/DQ0 ~ A/DQ15
- Read While Program/Erase Operation
- Multiple Bank Architecture
 - 16 Banks (16Mb Partition)
- OTP Block : Extra 512-Word block
- Read Access Time (@ $C_L=30pF$)
 - Asynchronous Random Access Time : 100ns
 - Synchronous Random Access Time : 100ns
 - Burst Access Time :
 - 11ns (66MHz), 9ns(83MHz), 7ns (108MHz), 6ns(133MHz)
- Burst Length :
 - Continuous Linear Burst
 - Linear Burst : 8-word & 16-word with No-wrap & Wrap
- Block Architecture
 - Four 16Kword blocks and two hundreds fifty-five 64Kword blocks
 - Bank 0 contains four 16 Kword blocks and fifteen 64Kword blocks
 - Bank 1 ~ Bank 15 contain two hundred forty 64Kword blocks
- Reduce program time using the V_{PP}
- Support 32 words Buffer Program
- Power Consumption (Typical value, $C_L=30pF$)
 - Synchronous Read Current : 35mA at 133MHz
 - Program/Erase Current : 25mA
 - Read While Program/Erase Current : 45mA
 - Standby Mode/Auto Sleep Mode : 30uA
- Block Protection/Unprotection
 - Using the software command sequence
 - Last two boot blocks are protected by $\overline{WP}=V_{IL}$
 - All blocks are protected by $V_{PP}=V_{IL}$
- Handshaking Feature
 - Provides host system with minimum latency by monitoring RDY
- Erase Suspend/Resume
- Program Suspend/Resume
- Unlock Bypass Program/Erase
- Hardware Reset (\overline{RESET})
- Data Polling and Toggle Bits
 - Provides a software method of detecting the status of program or erase completion
- Endurance
 - 100K Program/Erase Cycles Minimum
- Data Retention : 10 years
- Extended Temperature : -25°C ~ 85°C
- Support Common Flash Memory Interface
- Low V_{cc} Write Inhibit
- Package : 88 - ball FBGA Type (8mm x 11mm),
 - 0.8 mm ball pitch,
 - 1.2mm (Max.) Thickness
- 44 - ball FBGA Type (8mm x 9mm),
 - 0.5 mm ball pitch,
 - 1.0mm (Max.) Thickness

GENERAL DESCRIPTION

The K8F56(57)15E featuring single 1.8V power supply is a 256Mbit Muxed Burst Multi Bank Flash Memory organized as 16Mx16. The memory architecture of the device is designed to divide its memory arrays into 259 blocks with independent hardware protection. This block architecture provides highly flexible erase and program capability. The K8F56(57)15E NOR Flash consists of sixteen banks. This device is capable of reading data from one bank while programming or erasing in the other bank.

Regarding read access time, the K8F5615E provides an 11ns burst access time and an 100ns initial access time at 66MHz. At 83MHz, the K8F5615E provides an 9ns burst access time and an 100ns initial access time. At 108MHz, the K8F5715E provides an 7ns burst access time and an 100ns initial access time. At 133MHz, the K8F5715E provides an 6ns burst access time and an 100ns initial access time. The device performs a program operation in units of 16 bits (Word) and erases in units of a block. Single or multiple blocks can be erased. The block erase operation is completed within typically 0.6sec. The device requires 25mA as program/erase current in the extended temperature ranges.

The K8F56(57)15E NOR Flash Memory is created by using Samsung's advanced CMOS process technology. This device is available in 44ball / 88 ball FBGA package.

PIN DESCRIPTION

Pin Name	Pin Function
A16 - A23	Address Inputs
A/DQ0 - A/DQ15	Multiplexed Address/Data input/output
\overline{CE}	Chip Enable
\overline{OE}	Output Enable
\overline{RESET}	Hardware Reset
V _{PP}	Accelerates Programming
\overline{WE}	Write Enable
\overline{WP}	Hardware Write Protection Input
CLK	Clock
RDY	Ready Output
\overline{AVD}	Address Valid Input
DPD	Deep Power Down
V _{cc}	Power Supply
V _{ss}	Ground

SAMSUNG ELECTRONICS CO., LTD. reserves the right to change products and specifications without notice.

88 Ball FBGA TOP VIEW (BALL DOWN)

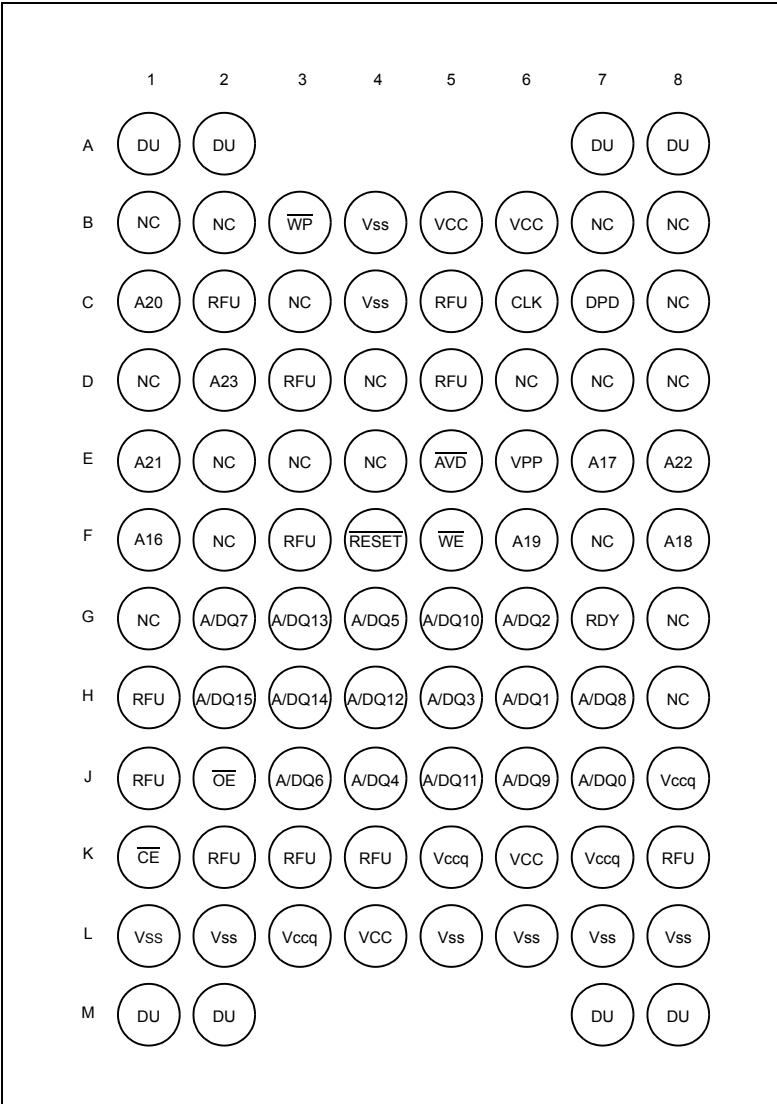

44 Ball FBGA TOP VIEW (BALL DOWN)

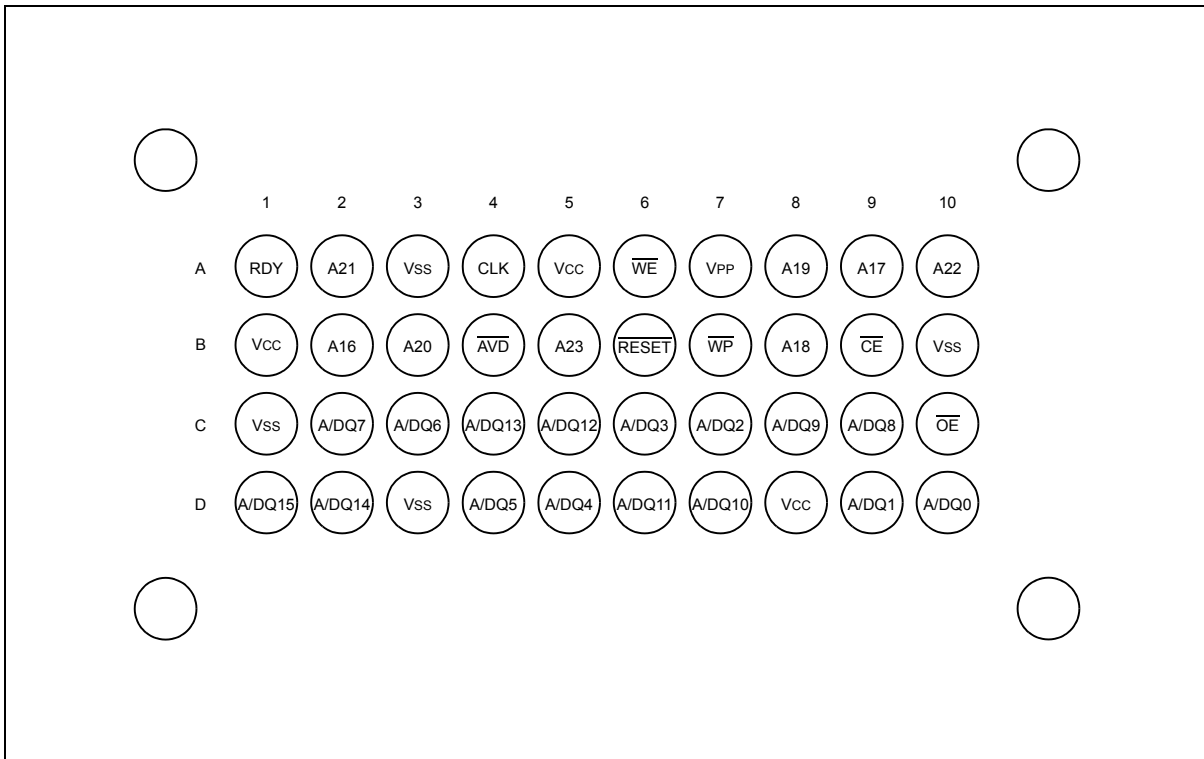

FUNCTIONAL BLOCK DIAGRAM

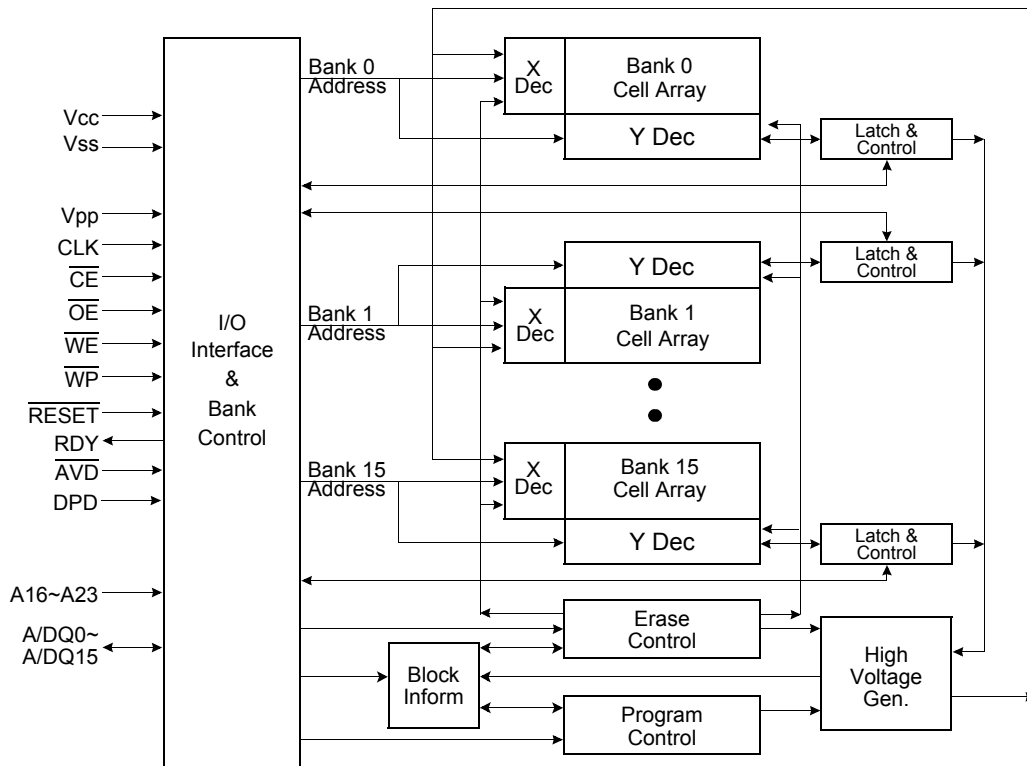

ORDERING INFORMATION

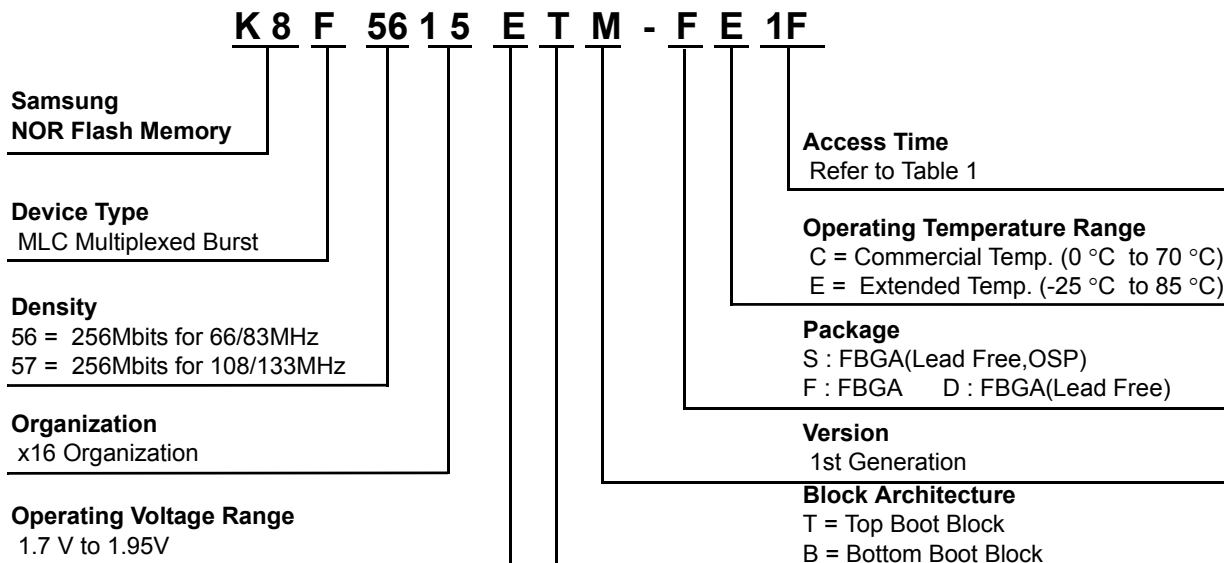

Table 1. PRODUCT LINE-UP

K8F56(57)15ET						
	Mode	Speed Option	1C (66MHz)	1D (83MHz)	1E (108MHz)	1F (133MHz)
Vcc=1.7V -1.95V	Synchronous/Burst	Max. Initial Access Time (t _{IA} , ns)	100	100	100	100
		Max. Burst Access Time (t _{BA} , ns)	11	9	7	6
	Asynchronous	Max. Access Time (t _{AA} , ns)	100	100	100	100
		Max. \overline{CE} Access Time (t _{CE} , ns)	100	100	100	100
		Max. \overline{OE} Access Time (t _{OE} , ns)	15	15	15	15

Table 1-1. PRODUCT Classification

Speed/Boot Option	Top	Bottom
256Mb for 66/83MHz	K8F5615ETM	K8F5615EBM
256Mb for 108/133MHz	K8F5715ETM	K8F5715EBM

Table 2. K8F56(57)15E DEVICE BANK DIVISIONS

Bank 0		Bank 1 ~ Bank 15	
Mbit	Block Sizes	Mbit	Block Sizes
16 Mbit	Four 16Kwords, fifteen 64Kwords	240 Mbit	Two hundred forty 64Kwords

Table 3-1. K8F56(57)15ETM DEVICE BANK DIVISIONS (Top Boot Block)

Bank	Quantity of Blocks	Block Size
0	4	16 Kwords
	15	64 Kwords
1	16	64 Kwords
2	16	64 Kwords
3	16	64 Kwords
4	16	64 Kwords
5	16	64 Kwords
6	16	64 Kwords
7	16	64 Kwords
8	16	64 Kwords
9	16	64 Kwords
10	16	64 Kwords
11	16	64 Kwords
12	16	64 Kwords
13	16	64 Kwords
14	16	64 Kwords
15	16	64 Kwords

Table 3-2. K8F56(57)15EBM DEVICE BANK DIVISIONS (Bottom Boot Block)

Bank	Quantity of Blocks	Block Size
15	16	64 Kwords
14	16	64 Kwords
13	16	64 Kwords
12	16	64 Kwords
11	16	64 Kwords
10	16	64 Kwords
9	16	64 Kwords
8	16	64 Kwords
7	16	64 Kwords
6	16	64 Kwords
5	16	64 Kwords
4	16	64 Kwords
3	16	64 Kwords
2	16	64 Kwords
1	16	64 Kwords
0	15	64 Kwords
	4	16 Kwords

PRODUCT INTRODUCTION

The K8F56(57)15E is an 256Mbit (268,435,456 bits) NOR-type Burst Flash memory. The device features 1.8V single voltage power supply operating within the range of 1.7V to 1.95V. The device is programmed by using the Channel Hot Electron (CHE) injection mechanism which is used to program EPROMs. The device is erased electrically by using Fowler-Nordheim tunneling mechanism. To provide highly flexible erase and program capability, the device adapts a block memory architecture that divides its memory array into 259 blocks (64-Kword x255, 16-Kword x 4,). Programming is done in units of 16 bits (Word). All bits of data in one or multiple blocks can be erased when the device executes the erase operation. To prevent the device from accidental erasing or over-writing the programmed data, 259 memory blocks can be hardware protected. Regarding read access time, at 66MHz, the K8F5615E provides a burst access of 11ns with initial access times of 100ns at 30pF. At 83MHz, the K8F5615E provides a burst access of 9ns with initial access times of 100ns at 30pF. At 108MHz, the K8F5715E provides a burst access of 7ns with initial access times of 100ns at 30pF. At 133MHz, the K8F5715E provides a burst access of 6ns with initial access times of 100ns at 30pF. The command set of K8F56(57)15E is compatible with standard Flash devices. The device uses Chip Enable (\overline{CE}), Write Enable (\overline{WE}), Address Valid (\overline{AVD}) and Output Enable (\overline{OE}) to control asynchronous read and write operation. For burst operations, the device additionally requires Ready (RDY) and Clock (CLK). Device operations are executed by selective command codes. The command codes to be combined with addresses and data are sequentially written to the command registers using microprocessor write timing. The command codes serve as inputs to an internal state machine which controls the program/erase circuitry. Register contents also internally latch addresses and data necessary to execute the program and erase operations. The K8F56(57)15E is implemented with Internal Program/Erase Routines to execute the program/erase operations. The Internal Program/Erase Routines are invoked by program/erase command sequences. The Internal Program Routine automatically programs and verifies data at specified addresses. The Internal Erase Routine automatically pre-programs the memory cell which is not programmed and then executes the erase operation. The K8F56(57)15E has means to indicate the status of completion of program/erase operations. The status can be indicated via Data polling of DQ7, or the Toggle bit (DQ6). Once the operations have been completed, the device automatically resets itself to the read mode. The device requires only 35 mA as burst and asynchronous mode read current and 25mA for Buffer program/erase operations.

Table 4. Device Bus Operations

Operation	\overline{CE}	\overline{OE}	\overline{WE}	A16-23	A/DQ0-15	\overline{RESET}	CLK	\overline{AVD}
Asynchronous Read Operation	L	L	H	Add In	Add In/ DOUT	H	L	
Write	L	H	L	Add In	Add In / DIN	H	L	
Standby	H	X	X	X	High-Z	H	X	X
Hardware Reset	X	X	X	X	High-Z	L	X	X
Load Initial Burst Address	L	H	H	Add In	Add In	H		
Burst Read Operation	L	L	H	X	Burst DOUT	H		H
Terminate Burst Read Cycle	H	X	X	X	High-Z	H	X	X
Terminate Burst Read Cycle via \overline{RESET}	X	X	X	X	High-Z	L	X	X
Terminate Current Burst Read Cycle and Start New Burst Read Cycle	L	H	H	Add In	Add In	H		

Note : L=V_{IL} (Low), H=V_{IH} (High), X=Don't Care.

COMMAND DEFINITIONS

The K8F56(57)15E operates by selecting and executing its operational modes. Each operational mode has its own command set. In order to select a certain mode, a proper command with specific address and data sequences must be written into the command register. Writing incorrect information which include address and data or writing an improper command will reset the device to the read mode. The defined valid register command sequences are stated in Table 5.

Table 5. Command Sequences

Command Definitions		Cycle	1st Cycle	2nd Cycle	3rd Cycle	4th Cycle	5th Cycle	6th Cycle
Asynchronous Read	Add	1	RA					
	Data		RD					
Reset(Note 5)	Add	1	XXXH					
	Data		F0H					
Autoselect Manufacturer ID(Note 6)	Add	4	555H	2AAH	(DA)555H	(DA)X00H		
	Data		AAH	55H	90H	ECH		
Autoselect Device ID(Note 6)	Add	4	555H	2AAH	(DA)555H	(DA)X01H		
	Data		AAH	55H	90H	Note 6		
Autoselect Block Protection Verify(Note 7)	Add	4	555H	2AAH	(BA)555H	(BA)X02H		
	Data		AAH	55H	90H	00H/01H		
Program	Add	4	555H	2AAH	555H	PA		
	Data		AAH	55H	A0H	PD		
Unlock Bypass	Add	3	555H	2AAH	555H			
	Data		AAH	55H	20H			
Unlock Bypass Program(Note 8)	Add	2	XXX	PA				
	Data		A0H	PD				
Unlock Bypass Block Erase(Note 8)	Add	2	XXX	BA				
	Data		80H	30H				
Unlock Bypass Chip Erase(Note 8)	Add	2	XXXH	XXXH				
	Data		80H	10H				
Unlock Bypass Reset	Add	2	XXXH	XXXH				
	Data		90H	00H				
Chip Erase	Add	6	555H	2AAH	555H	555H	2AAH	555H
	Data		AAH	55H	80H	AAH	55H	10H
Block Erase	Add	6	555H	2AAH	555H	555H	2AAH	BA
	Data		AAH	55H	80H	AAH	55H	30H
Erase Suspend (Note 9)	Add	1	(DA)XXXH					
	Data		B0H					
Erase Resume (Note 10)	Add	1	(DA)XXXH					
	Data		30H					
Program Suspend (Note 11)	Add	1	(DA)XXXH					
	Data		B0H					
Program Resume (Note 10)	Add	1	(DA)XXXH					
	Data		30H					
Block Protection/Unprotection (Note 12)	Add	3	XXX	XXX	ABP			
	Data		60H	60H	60H			
CFI Query (Note 13)	Add	1	(DA)X55H					
	Data		98H					

Table 5. Command Sequences (Continued)

Command Definitions		Cycle	1st Cycle	2nd Cycle	3rd Cycle	4th Cycle	5th Cycle	6th Cycle
Write to Buffer (Note 14)	Add	3	555H	2AAH	BA	BA	PA	WBL
	Data		AAH	55H	25H	WC	PD	PD
Program buffer to Flash (Note 14)	Add	1	BA					
	Data		29H					
Write to Buffer Abort Reset (Note 15)	Add	3	555H	2AAH	XXX			
	Data		AAH	55H	F0H			
Set Burst Mode Configuration Register (Note 16)	Add	3	555H	2AAH	Note 17			
	Data		AAH	55H	C0H			
Enter OTP Block Region	Add	3	555H	2AAH	XXX			
	Data		AAH	55H	70H			
Exit OTP Block Region	Add	4	555H	2AAH	555H	XXX		
	Data		AAH	55H	75H	00H		

Notes:

- RA : Read Address , PA : Program Address, RD : Read Data, PD : Program Data , BA : Block Address (A23 ~ A14), DA : Bank Address (A23 ~ A20)
ABP : Address of the block to be protected or unprotected , DI : Die revision ID, CR : Configuration Register Setting,
WBL : Write Buffer Location, WC : Word Count
- The 4th cycle data of autoselect mode and RD are output data. The others are input data.
- Data bits DQ15–DQ8 are don't care in command sequences, except for RD, PD and Device ID.
- Unless otherwise noted, address bits A23–A11 are don't cares.
- The reset command is required to return to read mode.
If a bank entered the autoselect mode during the erase suspend mode, writing the reset command returns that bank to the erase suspend mode.
If a bank entered the autoselect mode during the program suspend mode, writing the reset command returns that bank to the program suspend mode.
If DQ5 goes high during the program or erase operation, writing the reset command returns that bank to read mode or erase suspend mode if that bank was in erase suspend mode.
- The 3rd and 4th cycle bank address of autoselect mode must be same.
Device ID Data : "2208H" for Top Boot Block Device, "2209H" for Bottom Boot Block Device
- Normal Block Protection Verify : 00H for an unprotected block and 01H for a protected block.
OTP Block Protect verify (with OTP Block Address after Entering OTP Block) : 00H for unlocked, and 01H for locked.
- The unlock bypass command sequence is required prior to this command sequence.
- The system may read and program in non-erasing blocks when in the erase suspend mode.
The system may enter the autoselect mode when in the erase suspend mode.
The erase suspend command is valid only during a block erase operation, and requires the bank address.
- The erase/program resume command is valid only during the erase/program suspend mode, and requires the bank address.
- This mode is used only to enable Data Read by suspending the Program operation.
- Set block address(BA) as either A6 = VIH, A1 = VIH and A0 = VIL for unprotected or A6 = VIL, A1 = VIH and A0 = VIL for protected.
- Command is valid when the device is in Read mode or Autoselect mode.
- For Buffer Program, Firstly Enter "Write to Buffer" Command sequence and then Enter Block Address and Word Count which is the number of word data will be programmed. Word Count is smaller than the number of data wanted to program by one, Example if 15 words need to be programmed WC (Word Count) should be 14. After Entering Command, Enter PA/PD's (Program Addresses/ Program Data). Finally Enter "Program buffer to Flash" Command sequence, This starts a buffer program operation. This Device supports 32 words Buffer Program.
There is some caution points.
- The number of PA/PD's which are entered must be WC+1
- PA's which are entered must be same A23~A5 address bits because Buffer Address is A23~A5 address and decided by PA entered firstly.
- If PA which are entered isn't same Buffer Address, then PA/PD which is entered may not be counted and not stored to Buffer.
- Overwrite for program buffer is also prohibited.
- Command sequence resets device for next command after aborted write-to-buffer operation.
- See "Set Burst Mode Configuration Register" for details.
- On the third cycle, the data should be "C0h", address bits A10-A0 should be 101_0101_0101b, and address bits A18-A11 set the code to be latched.

DEVICE OPERATION

The device has inputs/outputs that accept both address and data information. To write a command or command sequence (which includes programming data to the device and erasing blocks of memory), the system must drive CLK, \overline{AVD} and \overline{CE} to V_{IL} and \overline{OE} to V_{IH} when providing an address to the device, and drive CLK, WE and CE to V_{IL} and \overline{OE} to V_{IH} when writing commands or data.

The device provide the unlock bypass mode to save its program time for program operation. Unlike the standard program command sequence which is comprised of four bus cycles, only two program cycles are required to program a word in the unlock bypass mode. One block, multiple blocks, or the entire device can be erased. Table 12 indicates the address space that each block occupies. The device's address space is divided into sixteen banks: Bank 0 contains the boot/parameter blocks, and the other banks(from Bank 1 to 15) consist of uniform blocks. A "bank address" is the address bits required to uniquely select a bank. Similarly, a "block address" is the address bits required to uniquely select a block. Icc2 in the DC Characteristics table represents the active current specification for the write mode. The AC Characteristics section contains timing specification tables and timing diagrams for write operations.

Read Mode

The device automatically enters to asynchronous read mode after device power-up. No commands are required to retrieve data in asynchronous mode. After completing an Internal Program/Erase Routine, each bank is ready to read array data. The reset command is required to return a bank to the read(or erase-suspend-read)mode if DQ5 goes high during an active program/erase operation, or if the bank is in the autoselect mode.

The synchronous(burst) mode will **automatically** be enabled on the first rising edge on the CLK input while \overline{AVD} is held low. That means device enters from asynchronous read mode to burst read mode using CLK and \overline{AVD} signal. When the burst read is terminated, the device return to asynchronous read mode automatically.

Asynchronous Read Mode

For the asynchronous read mode a valid address should be asserted on A/DQ0-A/DQ15 and A16-A23, while driving \overline{AVD} and \overline{CE} to V_{IL} . \overline{WE} and \overline{OE} should remain at V_{IH} . Note that CLK must remain low for asynchronous read mode. The address is latched at the rising edge of \overline{AVD} , and then the system can drive \overline{OE} to V_{IL} . The data will appear on A/DQ0-A/DQ15. Since the memory array is divided into sixteen banks, each bank remains enabled for read access until the command register contents are altered.

Address access time (t_{AA}) is equal to the delay from valid addresses to valid output data. The chip enable access time(t_{CE}) is the delay from the falling edge of \overline{CE} to valid data at the outputs. The output enable access time(t_{OE}) is the delay from the falling edge of \overline{OE} to valid data at the output. The asynchronous access time is measured from a valid address, falling edge of \overline{AVD} or falling edge of \overline{CE} whichever occurs last. To prevent the memory content from spurious altering during power transition, the initial state machine is set for reading array data upon device power-up, or after a hardware reset.

Synchronous (Burst) Read Mode

The device is capable of continuous linear burst operation and linear burst operation of a preset length. For the burst mode, the system should determine how many clock cycles are desired for the initial word(t_{IAA}) of each burst access and what mode of burst operation is desired using "Burst Mode Configuration Register" command sequences. See "Set Burst Mode Configuration" for further details. The status data also can be read by synchronous read mode with a bank address which is programming or erasing. This status data by synchronous read mode can be output just once and then synchronous read mode will be terminated. Refer to Figure 8. To initiate the synchronous read again, a new address and \overline{AVD} pulse is needed after the host has completed status reads or the device has completed the program or erase operation.

Continuous Linear Burst Read

The synchronous(burst) mode will **automatically** be enabled on the first rising edge on the CLK input while \overline{AVD} is held low. Note that the device is enabled for asynchronous mode when it first powers up. The initial word is output t_{IAA} after the rising edge of the first CLK cycle. Subsequent words are output t_{BA} after the rising edge of each successive clock cycle, which automatically increments the internal address counter. Note that the device has internal address boundary that occurs every 16 words. When the device is crossing the first word boundary, additional clock cycles are needed before data appears for the next address. The number of additional clock cycle can vary from zero to fourteen cycles, and the exact number of additional clock cycle depends on the starting address of burst read.(Refer to Figure 18) The RDY output indicates this condition to the system by pulsing low. The device will continue to output sequential burst data, wrapping around to address 000000h after it reaches the highest addressable memory location until the system asserts \overline{CE} high, RESET low or \overline{AVD} low in conjunction with a new address.(See Table 4.) The reset command does not terminate the burst read operation. When it accesses the bank is programming or erasing, continuous burst read mode will be terminated after status data output once.

Note that at least 10ns is needed to start next burst read operation from terminating previous burst read operation in the case of asserting CE high.

8-, 16-Word Linear Burst Read

As well as the Continuous Linear Burst Mode, there are two(8 & 16 word) linear wrap & no-wrap mode, in which a fixed number of words are read from consecutive addresses. In these modes, the addresses for burst read are determined by the group within which the starting address falls. The groups are sized according to the number of words read in a single burst sequence for a given mode.(See Table. 6)

Table 6. Burst Address Groups(Wrap mode only)

Burst Mode	Group Size	Group Address Ranges
8 word	8 words	0-7h, 8-Fh, 10-17h,
16 word	16words	0-Fh, 10-1Fh, 20-2Fh,

As an example: In wrap mode case, if the starting address in the 8-word mode is 2h, the address range to be read would be 0-7h, and the wrap burst sequence would be 2-3-4-5-6-7-0-1h. The burst sequence begins with the starting address written to the device, but wraps back to the first address in the selected group. In a similar manner, 16-word wrap mode begin their burst sequence on the starting address written to the device, and then wrap back to the first address in the selected address group.

In no-wrap mode case, if the starting address in the 8-word mode is 2h, the no-wrap burst sequence would be 2-3-4-5-6-7-8-9h. The burst sequence begins with the starting address written to the device, and continue to the 8th address from starting address. In a similar manner, 16-word no-wrap mode begin their burst sequence on the starting address written to the device, and continue to the 16th address from starting address. Also, when the address cross the word boundary in no-wrap mode, same number of additional clock cycles as continuous linear mode is needed.

Programmable Wait State

The programmable wait state feature indicates to the device the number of additional clock cycles that must elapse after \overline{AVD} is driven from low to high for burst read mode. Upon power up, the number of total initial access cycles defaults to fourteen.

Handshaking

The handshaking feature allows the host system to simply monitor the RDY signal from the device to determine when the initial word of burst data is ready to be read. To set the number of initial cycle for optimal burst mode, the host should use the programmable wait state configuration.(See "Set Burst Mode Configuration Register" for details.) The rising edge of RDY after \overline{OE} goes low indicates the initial word of valid burst data. Using the autoselect command sequence the handshaking feature may be verified in the device.

Set Burst Mode Configuration Register

The device uses a configuration register to set the various burst parameters : the number of initial cycles for burst and burst read mode. The burst mode configuration register must be set before the device enter burst mode.

The burst mode configuration register is loaded with a three-cycle command sequences. On the third cycle, the data should be C0h, address bits A10-A0 should be 101_0101_0101b, and address bits A18-A11 set the code to be latched. The device will power up or after a hardware reset with the default setting.

Table 7. Burst Mode Configuration Register Table

Address Bit	Function	Settings(Binary)
A18	RDY Active	1 = RDY active one clock cycle before data 0 = RDY active with data(default)
A17	Burst Read Mode	000 = Continuous(default)
A16		001 = 8-word linear with wrap
A15		010 = 16-word linear with wrap 011 = 8-word linear with no-wrap 100 = 16-word linear with no-wrap 101~111 = Reserve
A14	Programmable Wait State	0000 = Data is valid on the 4th active CLK edge after \overline{AVD} transition to V_{IH} (40MHz)
A13		0001 = Data is valid on the 5th active CLK edge after \overline{AVD} transition to V_{IH} (50MHz)
A12		0010 = Data is valid on the 6th active CLK edge after \overline{AVD} transition to V_{IH} (54/60MHz)
A11		0011 = Data is valid on the 7th active CLK edge after \overline{AVD} transition to V_{IH} (66/70MHz)
		0100 = Data is valid on the 8th active CLK edge after \overline{AVD} transition to V_{IH} (80MHz)
		0101 = Data is valid on the 9th active CLK edge after \overline{AVD} transition to V_{IH} (83/90MHz)
		0110 = Data is valid on the 10th active CLK edge after \overline{AVD} transition to V_{IH} (100MHz)
	0111 = Data is valid on the 11th active CLK edge after \overline{AVD} transition to V_{IH} (108/110MHz)	
	1000 = Data is valid on the 12th active CLK edge after \overline{AVD} transition to V_{IH} (120MHz)	
	1001 = Data is valid on the 13th active CLK edge after \overline{AVD} transition to V_{IH}	
	1010 = Data is valid on the 14th active CLK edge after \overline{AVD} transition to V_{IH} (default, at 133MHz)	
	1011 = Data is valid on the 15th active CLK edge after \overline{AVD} transition to V_{IH}	
	1100~1111 = Reserve	

Note:

Initial wait state should be set according to it's clock frequency. Table7 recommend the program wait state for each clock frequencies.

Not 100% tested

Programmable Wait State Configuration

This feature informs the device the number of clock cycles that must elapse after \overline{AVD} is driven from low to high before data will be available. This value is determined by the input frequency of the device. Address bits A14-A11 determine the setting. (See Burst Mode Configuration Register Table) The Programmable wait state setting instructs the device to set a particular number of clock cycles for the initial access in burst mode. Note that hardware reset will set the wait state to the default setting, that is 14 initial cycles.

Burst Read Mode Setting

The device supports five different burst read modes : continuous linear mode, 8 and 16 word linear burst modes with wrap and 8 and 16 word linear burst modes with no-wrap.

RDY Configuration

By default, the RDY pin will be high whenever there is valid data on the output. The device can be set so that RDY goes active one data cycle before active data. Address bit A18 determine this setting. The RDY pin behaves same way in word boundary crossing case.

Table 8. Burst Address Sequences

	Start Addr.	Burst Address Sequence(Decimal)		
		Continuous Burst	8-word Burst	16-word Burst
Wrap	0	0-1-2-3-4-5-6...	0-1-2-3-4-5-6-7	0-1-2-3 ... -D-E-F
	1	1-2-3-4-5-6-7...	1-2-3-4-5-6-7-0	1-2-3-4 ... -E-F-0
	2	2-3-4-5-6-7-8...	2-3-4-5-6-7-0-1	2-3-4-5 ... -F-0-1

No-wrap	0	0-1-2-3-4-5-6...	0-1-2-3-4-5-6-7	0-1-2-3 ... -D-E-F
	1	1-2-3-4-5-6-7...	1-2-3-4-5-6-7-8	1-2-3-4 ... -E-F-10
	2	2-3-4-5-6-7-8...	2-3-4-5-6-7-8-9	2-3-4-5 ... -F-10-11

Autoselect Mode

By writing the autoselect command sequences to the system, the device enters the autoselect mode. This mode can be read only by asynchronous read mode. The system can then read autoselect codes from the internal register(which is separate from the memory array). Standard asynchronous read cycle timings apply in this mode. The device offers the Autoselect mode to identify manufacturer and device type by reading a binary code. In addition, this mode allows the host system to verify the block protection or unprotection. Table 5 shows the address and data requirements. The autoselect command sequence may be written to an address within a bank that is in the read mode, erase-suspend-read mode or program-suspend-read mode. The autoselect command may not be written while the device is actively programming or erasing in the device. The autoselect command sequence is initiated by first writing two unlock cycles. This is followed by a third write cycle that contains the address and the autoselect command. Note that the block address is needed for the verification of block protection. The system may read at any address within the same bank any number of times without initiating another autoselect command sequence. And the burst read should be prohibited during Autoselect Mode. To terminate the autoselect operation, write Reset command(FOH) into the command register.

Table 9. Autoselect Mode Description

Description	Address	Read Data
Manufacturer ID	(DA) + 00H	ECH
Device ID	(DA) + 01H	2208H(Top Boot Block), 2209H(Bottom Boot Block)
Block Protection/Unprotection	(BA) + 02H	01H (protected), 00H (unprotected)

Standby Mode

When the CE inputs is held at $V_{CC} \pm 0.2V$, and the system is not reading or writing, the device enters Stand-by mode to minimize the power consumption. In this mode, the device outputs are placed in the high impedance state, independent of the OE input. When the device is in either of these standby modes, the device requires standard access time (tCE) for read access before it is ready to read data. If the device is deselected during erasure or programming, the device draws active current until the operation is completed. I_{CCS} in the DC Characteristics table represents the standby current specification.

Automatic Sleep Mode

The device features Automatic Sleep Mode to minimize the device power consumption during both asynchronous and burst mode. When addresses remain stable for $t_{AA}+60ns$, the device automatically enables this mode. The Automatic sleep mode is depends on the \overline{CE} , \overline{WE} and \overline{OE} signal, so \overline{CE} , \overline{WE} and \overline{OE} signals are held at any state. In a sleep mode, output data is latched and always available to the system. When \overline{OE} is active, the device provides new data without wait time. Automatic sleep mode current is equal to standby mode current.

Output Disable Mode

When the \overline{OE} input is at V_{IH} , output from the device is disabled. The outputs are placed in the high impedance state.

Block Protection & Unprotection

To protect the block from accidental writes, the block protection/unprotection command sequence is used. On power up, all blocks in the device are protected. To unprotect a block, the system must write the block protection/unprotection command sequence. The first two cycles are written: addresses are don't care and data is 60h. Using the third cycle, the block address (ABP) and command (60h) is written, while specifying with addresses A6, A1 and A0 whether that block should be protected (A6 = V_{IL} , A1 = V_{IH} , A0 = V_{IL}) or unprotected (A6 = V_{IH} , A1 = V_{IH} , A0 = V_{IL}). After the third cycle, the system can continue to protect or unprotect additional cycles, or exit the sequence by writing F0h (reset command).

The device offers three types of data protection at the block level:

- The block protection/unprotection command sequence disables or re-enables both program and erase operations in any block.
- When \overline{WP} is at V_{IL} , the two outermost blocks are protected.
- When V_{PP} is at V_{IL} , all blocks are protected.

Note that user never float the V_{pp} and \overline{WP} , that is, V_{pp} is always connected with V_{IH} , V_{IL} or V_{ID} and \overline{WP} is V_{IH} or V_{IL} .

Hardware Reset

The device features a hardware method of resetting the device by the \overline{RESET} input. When the \overline{RESET} pin is held low(V_{IL}) for at least a period of t_{RP} , the device immediately terminates any operation in progress, tristates all outputs, and ignores all read/write commands for the duration of the \overline{RESET} pulse. The device also resets the internal state machine to asynchronous read mode. To ensure data integrity, the interrupted operation should be reinitiated once the device is ready to accept another command sequence. As previously noted, when \overline{RESET} is held at $V_{SS} \pm 0.2V$, the device enters standby mode. The \overline{RESET} pin may be tied to the system reset pin. If a system reset occurs during the Internal Program or Erase Routine, the device will be automatically reset to the asynchronous read mode; this will enable the systems microprocessor to read the boot-up firmware from the Flash memory. If \overline{RESET} is asserted during a program or erase operation, the device requires a time of t_{READY} (during Internal Routines) before the device is ready to read data again. If \overline{RESET} is asserted when a program or erase operation is not executing, the reset operation is completed within a time of t_{READY} (not during Internal Routines). t_{RH} is needed to read data after \overline{RESET} returns to V_{IH} . Refer to the AC Characteristics tables for \overline{RESET} parameters and to Figure 10 for the timing diagram.

Software Reset

The reset command provides that the bank is reseted to read mode, erase-suspend-read mode or program-suspend-read mode. The addresses are in Don't Care state. The reset command may be written between the sequence cycles in an erase command sequence before erasing begins, or in an program command sequence before programming begins. If the device begins erasure or programming, the reset command is ignored until the operation is completed. If the program command sequence is written to a bank that is in the Erase Suspend mode, writing the reset command returns that bank to the erase-suspend-read mode. The reset command valid between the sequence cycles in an autoselect command sequence. In an autoselect mode, the reset command must be written to return to the read mode. If a bank entered the autoselect mode while in the Erase Suspend mode, writing the reset command returns that bank to the erase-suspend-read mode. Also, if a bank entered the autoselect mode while in the Program Suspend mode, writing the reset command returns that bank to the program-suspend-read mode. If DQ5 goes high during a program or erase operation, writing the reset command returns the banks to the read mode. (or erase-suspend-read mode if the bank was in Erase Suspend)

Program

The K8F56(57)15E can be programmed in units of a word. Programming is writing 0's into the memory array by executing the Internal Program Routine. In order to perform the Internal Program Routine, a four-cycle command sequence is necessary. The first two cycles are unlock cycles. The third cycle is assigned for the program setup command. In the last cycle, the address of the memory location and the data to be programmed at that location are written. The device automatically generates adequate program pulses and verifies the programmed cell margin by the Internal Program Routine. During the execution of the Routine, the system is not required to provide further controls or timings. During the Internal Program Routine, commands written to the device will be ignored. Note that a hardware reset during a program operation will cause data corruption at the corresponding location.

Accelerated Program

The device provides accelerated program operations through the Vpp input. Using this mode, faster manufacturing throughput at the factory is possible. When VID is asserted on the Vpp input, the device automatically enters the Unlock Bypass mode, temporarily unprotects any protected blocks, and uses the higher voltage on the input to reduce the time required for program operations. In accelerated program mode, the system would use a two-cycle program command sequence for only a word program. By removing VID returns the device to normal operation mode.

Note that Read While Accelerated Program and Program suspend mode are not guaranteed.

- Program/Erase cycling must be limited below 100cycles for optimum performance.
- Ambient temperature requirements : $T_A = 30^{\circ}\text{C} \pm 10^{\circ}\text{C}$

Single word accelerated program operation

The system would use two-cycle program sequence (One-cycle (XXX - A0H) is for single word program command, and Next one-cycle (PA - PD) is for program address and data)

Writer Buffer Programming

Write Buffer Programming allows the system write to a maximum of 32 words in one programming operation. This results in faster effective programming time than the standard programming algorithms. The Write Buffer Programming command sequence is initiated by first writing two unlock cycles. This is followed by a third write cycle containing the Write Buffer Load command written at the block address in which programming will occur. The fourth cycle writes the block address and the number of word locations, minus one, to be programmed. For example, if the system will program 19 unique address locations, then 12h should be written to the device. This tells the device how many write buffer addresses will be loaded with data. The number of locations to program cannot exceed the size of the write buffer or the operation will abort. The fifth cycle writes the first address location and data to be programmed. **The write-buffer-page is selected by address bits A23(max.) ~ A5 entered at fifth cycle. All subsequent address/data pairs must fall within the selected write-buffer-page, so that all subsequent addresses must have the same address bit A23(max.) ~ A5 as those entered at fifth cycle. Write buffer locations may be loaded in any order.**

Once the specified number of write buffer locations have been loaded, the system must then write the "Program Buffer to Flash" command at the block address. Any other command address/data combination aborts the Write Buffer Programming operation. The device then begins programming. Data polling should be used while monitoring the last address location loaded into the write buffer. DQ7, DQ6, DQ5, and DQ1 should be monitored to determine the device status during Write Buffer Programming. The write-buffer programming operation can be suspended using the standard program suspend/resume commands. Upon successful completion of the Write Buffer Programming operation, the device is ready to execute the next command. Note also that an address location cannot be loaded more than once into the write-buffer-page.

The Write Buffer Programming Sequence can be aborted in the following ways:

- Loading a value that is greater than the buffer size(32-words) during then number of word locations to Program step.
(In case, WC > 1FH @Table5)
- The number of Program address/data pairs entered is different to the number of word locations initially defined with WC (@Table5)
- Writing a Program address to have a different write-buffer-page with selected write-buffer-page
(Address bits A23(max) ~ A5 are different)
- Writing non-exact "Program Buffer to Flash" command

The abort condition is indicated by DQ1 = 1, DQ7 = $\overline{\text{DATA}}$ (for the last address location loaded), DQ6 = toggle, and DQ5=0. A "Write-to-Buffer-Abort Reset" command sequence must be written to reset the device for the next operation. Note that the third cycle of Write-to-Buffer-Abort Reset command sequence(XXXh-F0h) is required when using Write-Buffer-Programming features in Unlock Bypass mode. And from the third cycle to the last cycle of Write to Buffer command is also required when using Write-Buffer-Programming features in Unlock Bypass mode. A bit cannot be programmed from "0" back to a "1." Attempting to do so may cause the device to set DQ5 = 1, or cause the DQ7 and DQ6 status bits to indicate the operation was successful. However, a succeeding read will show that the data is still "0." Only erase operations can convert a "0" to a "1."

Accelerated Write Buffer Programming

The device provides accelerated Write Buffer Program operations through the Vpp input. Using this mode, faster manufacturing throughput at the factory is possible. When VID is asserted on the Vpp input, the device temporarily unprotects any protected blocks, and uses the higher voltage on the input to reduce the time required for program operations. In accelerated Write Buffer Program mode, the system must enter "Write to Buffer" and "Program Buffer to Flash" command sequence to be same as them of normal Write Buffer Programming and only can reduce the program time. Note that the third cycle of "Write to Buffer Abort Reset" command sequence(XXXh-F0h) is required to reset the device for the next operation in an Accelerated mode.

Note that Read While Accelerated Write Buffer Program and Program suspend mode are not guaranteed.

- Program/Erase cycling must be limited below 100cycles for optimum performance.

Chip Erase

To erase a chip is to write 1's into the entire memory array by executing the Internal Erase Routine. The Chip Erase requires six bus cycles to write the command sequence. The erase set-up command is written after first two "unlock" cycles. Then, there are two more write cycles prior to writing the chip erase command. The Internal Erase Routine automatically pre-programs and verifies the entire memory for an all zero data pattern prior to erasing. The automatic erase begins on the rising edge of the last \overline{WE} pulse in the command sequence and terminates when DQ7 is "1". After that the device returns to the read mode.

Block Erase

To erase a block is to write 1's into the desired memory block by executing the Internal Erase Routine. The Block Erase requires six bus cycles to write the command sequence shown in Table 5. After the first two "unlock" cycles, the erase setup command (80H) is written at the third cycle. Then there are two more "unlock" cycles followed by the Block Erase command. The Internal Erase Routine automatically pre-programs and verifies the entire memory prior to erasing it. The block address is latched on the rising edge of \overline{AVD} , while the Block Erase command is latched on the rising edge of \overline{WE} . Multiple blocks can be erased sequentially by writing the sixth bus-cycle. Upon completion of the last cycle for the Block Erase, additional block address and the Block Erase command (30H) can be written to perform the Multi-Block Erase. For the Multi-Block Erase, only sixth cycle(block address and 30H) is needed.(Similarly, only second cycle is needed in unlock bypass block erase.) An 50us (typical) "time window" is required between the Block Erase command writes. The Block Erase command must be written within the 50us "time window", otherwise the Block Erase command will be ignored. The 50us "time window" is reset when the falling edge of the \overline{WE} occurs within the 50us of "time window" to latch the Block Erase command. During the 50us of "time window", any command other than the Block Erase or the Erase Suspend command written to the device will reset the device to read mode. After the 50 us of "time window", the Block Erase command will initiate the Internal Erase Routine to erase the selected blocks. Any Block Erase address and command following the exceeded "time window" may or may not be accepted. No other commands will be recognized except the Erase Suspend command during Block Erase operation.

The device provides accelerated erase operations through the Vpp input. When VID is asserted on the Vpp input, the device automatically enters the Unlock Bypass mode, temporarily unprotects any protected blocks, and uses the higher voltage on the input to reduce the time required for erase. By removing VID returns the device to normal operation mode.

Unlock Bypass

The K8F56(57)15E provides the unlock bypass mode to save its operation time. This mode is possible for program, block erase and chip erase operation. There are two methods to enter the unlock bypass mode. The mode is invoked by the unlock bypass command sequence or the assertion of VID on VPP pin. Unlike the standard program/erase command sequence that contains four bus cycles, the unlock bypass program/erase command sequence comprises only two bus cycles. The unlock bypass mode is engaged by issuing the unlock bypass command sequence which is comprised of three bus cycles. Writing first two unlock cycles is followed by a third cycle containing the unlock bypass command (20H). Once the device is in the unlock bypass mode, the unlock bypass program/erase command sequence is necessary. The unlock bypass program command sequence is comprised of only two bus cycles; writing the unlock bypass program command (A0H) is followed by the program address and data. This command sequence is the only valid one for programming the device in the unlock bypass mode. Also, The unlock bypass erase command sequence is comprised of two bus cycles; writing the unlock bypass block erase command(80H-30H) or writing the unlock bypass chip erase command(80H-10H). This command sequences are the only valid ones for erasing the device in the unlock bypass mode. The unlock bypass reset command sequence is the only valid command sequence to exit the unlock bypass mode. The unlock bypass reset command sequence consists of two bus cycles. The first cycle must contain the data (90H). The second cycle contains only the data (00H). Then, the device returns to the read mode.

To enter the unlock bypass mode in hardware level, the VID also can be used. By assertion VID on the VPP pin, the device enters the unlock bypass mode. Also, the all blocks are temporarily unprotected when the device using the VID for unlock bypass mode. To exit the unlock bypass mode, just remove the asserted VID from the VPP pin.(Note that user never float the Vpp, that is, Vpp is always connected with VIH, VIL or VID.).

Erase Suspend / Resume

The Erase Suspend command interrupts the Block Erase to read or program data in a block that is not being erased. Also, it is possible to protect or unprotect of the block that is not being erased in erase suspend mode. The Erase Suspend command is only valid during the Block Erase operation including the time window of 50 us. The Erase Suspend command is not valid while the Chip Erase or the Internal Program Routine sequence is running. When the Erase Suspend command is written during a Block Erase operation, the device requires a maximum of 20 us(recovery time) to suspend the erase operation. Therefore system must wait for 20us(recovery time) to read the data from the bank which include the block being erased. Otherwise, system can read the data immediately from a bank which don't include the block being erased without recovery time(max. 20us) after Erase Suspend command. And, after the maximum 20us recovery time, the device is available for programming data in a block that is not being erased. But, when the Erase Suspend command is written during the block erase time window (50 us), the device immediately terminates the block erase time window and suspends the erase operation. The system may also write the autoselect command sequence when the device is in the Erase Suspend mode. When the Erase Resume command is executed, the Block Erase operation will resume. When the Erase Suspend or Erase Resume command is executed, the addresses are in Don't Care state.

In erase suspend followed by resume operation, min. 200ns is needed for checking the busy status.

Program Suspend / Resume

The device provides the Program Suspend/Resume mode. This mode is used to enable Data Read by suspending the Program operation. The device accepts a Program Suspend command in Program mode(including Program operations performed during Erase Suspend) but other commands are ignored. After input of the Program Suspend command, 5us is needed to enter the Program Suspend Read mode. Therefore system must wait for 5us(recovery time) to read the data from the bank which include the block being programmed. Otherwise, system can read the data immediately from a bank which don't include block being programmed without recovery time(max. 5us) after Program Suspend command. Like an Erase Suspend mode, the device can be returned to Program mode by using a Program Resume command. **In the program suspend mode, protect/unprotect command is prohibited.** In program suspend followed by resume operation, min. 200ns is needed for checking the busy status.

Read While Write Operation

The device is capable of reading data from one bank while writing in the other banks. This is so called the Read While Write operation. An erase operation may also be suspended to read from or program to another location within the same bank(except the block being erased). The Read While Write operation is prohibited during the chip erase operation. Figure 17 shows how read and write cycles may be initiated for simultaneous operation with zero latency. Refer to the DC Characteristics table for read-while-write current specifications.

OTP Block Region

The OTP Block feature provides a 512-word Flash memory region that enables permanent part identification through an Electronic Serial Number (ESN). The OTP Block is customer lockable and shipped with itself unlocked, allowing customers to utilize the that block in any manner they choose. The customer-lockable OTP Block has the Protection Verify Bit (DQ0) set to a "0" for Unlocked state or a "1" for Locked state.

The system accesses the OTP Block through a command sequence (see "Enter OTP Block / Exit OTP Block Command sequence" at Table 5). After the system has written the "Enter OTP Block" Command sequence, it may read the OTP Block by using the addresses (FFFF80h~FFFFFFh) normally and may check the Protection Verify Bit (DQ0) by using the "Autoselect Block Protection Verify" Command sequence with OTP Block address. This mode of operation continues until the system issues the "Exit OTP Block" Command sequence, a hardware reset or until power is removed from the device. On power-up, or following a hardware reset, the device reverts to sending commands to main blocks. Note that the Accelerated function and unlock bypass modes are not available when the OTP Block is enabled.

Customer Lockable

In a Customer lockable device, The OTP Block is one-time programmable and can be locked only once. Note that the Accelerated function and Unlock bypass functions are not available when programming the OTP Block. Locking operation to the OTP Block is started by writing the "Enter OTP Block" Command sequence, and then the "Block Protection" Command sequence (Table 5) with an OTP Block address. "Exit OTP Block" command sequence makes exiting from OTP Block. The Locking operation has to be above 100us. "Exit OTP Block" command sequence and Hardware reset makes locking operation finished and then exiting from OTP Block.

The OTP Block Lock operation must be used with caution since, once locked, there is no procedure available for unlocking and none of the bits in the OTP Block space can be modified in any way.

The OTP Block access is prohibited during program or erase suspend mode.

Low Vcc Write Inhibit

To avoid initiation of a write cycle during Vcc power-up and power-down, a write cycle is locked out for Vcc less than VLKO. If the Vcc < VLKO (Lock-Out Voltage), the command register and all internal program/erase circuits are disabled. Under this condition the device will reset itself to the read mode. Subsequent writes will be ignored until the Vcc level is greater than VLKO. It is the user's responsibility to ensure that the control pins are logically correct to prevent unintentional writes when Vcc is above VLKO.

Write Pulse "Glitch" Protection

Noise pulses of less than 5ns (typical) on \overline{OE} , \overline{CE} , \overline{AVD} or \overline{WE} do not initiate a write cycle.

Logical Inhibit

Write cycles are inhibited by holding any one of $\overline{OE} = V_{IL}$, $\overline{CE} = V_{IH}$ or $\overline{WE} = V_{IH}$. To initiate a write cycle, \overline{CE} and \overline{WE} must be a logical zero while \overline{OE} is a logical one.

FLASH MEMORY STATUS FLAGS

The K8F56(57)15E has means to indicate its status of operation in the bank where a program or erase operation is in processes. Address must include bank address being executed internal routine operation. The status is indicated by raising the device status flag via corresponding DQ pins. The status data can be read during burst read mode by using \overline{AVD} signal with a bank address. That means status read is supported in synchronous mode. If status read is performed, the data provided in the burst read is identical to the data in the initial access. To initiate the synchronous read again, a new address and \overline{AVD} pulse is needed after the host has completed status reads or the device has completed the program or erase operation. The corresponding DQ pins are DQ7, DQ6, DQ5, DQ3, DQ2 and DQ1.

Table 10. Hardware Sequence Flags

	Status	DQ7	DQ6	DQ5	DQ3	DQ2	DQ1	
In Progress	Programming	$\overline{DQ7}$	Toggle	0	0	1	0	
	Block Erase or Chip Erase	0	Toggle	0	1	Toggle	0	
	Erase Suspend Read	Erase Suspended Block	1	1	0	0	Toggle (Note 1)	0
	Erase Suspend Read	Non-Erase Suspended Block	Data	Data	Data	Data	Data	Data
	Erase Suspend Program	Non-Erase Suspended Block	$\overline{DQ7}$	Toggle	0	0	1	0
	Program Suspend Read	Program Suspended Block	DQ7	1	0	0	Toggle (Note 1)	0
	Program Suspend Read	Non-program Suspended Block	Data	Data	Data	Data	Data	Data
Exceeded Time Limits	Programming	$\overline{DQ7}$	Toggle	1	0	No Toggle	0	
	Block Erase or Chip Erase	0	Toggle	1	1	(Note 2)	0	
	Erase Suspend Program	$\overline{DQ7}$	Toggle	1	0	No Toggle	0	
Write-to-Buffer (Note3)	BUSY state	$\overline{DQ7}$	Toggle	0	0	No Toggle	0	
	Exceeded Timing Limits	$\overline{DQ7}$	Toggle	1	0	No Toggle	0	
	ABORT State	$\overline{DQ7}$	Toggle	0	0	No Toggle	1	

Notes :

1. DQ2 will toggle when the device performs successive read operations from the erase/program suspended block.
2. If DQ5 is High (exceeded timing limits), successive reads from a problem block will cause DQ2 to toggle.
3. Note that $\overline{DQ7}$ during Write-to-Buffer-Programming indicates the data-bar for DQ7 data for the last loaded write-buffer address location.

DQ7 : $\overline{DQ7}$ Data Polling

When an attempt to read the device is made while executing the Internal Program, the complement of the data is written to DQ7 as an indication of the Routine in progress. When the Routine is completed an attempt to access to the device will produce the true data written to DQ7. When a user attempts to read the block being erased, DQ7 will be low. If the device is placed in the Erase/Program Suspend Mode, the status can be detected via the DQ7 pin. If the system tries to read an address which belongs to a block that is being erase suspended, DQ7 will be high. And, if the system tries to read an address which belongs to a block that is being program suspended, the output will be the true data of DQ7 itself. If a non-erase-suspended or non-program-suspended block address is read, the device will produce the true data to DQ7. If an attempt is made to program a protected block, DQ7 outputs complements the data for approximately 1 μ s and the device then returns to the Read Mode without changing data in the block. If an attempt is made to erase a protected block, DQ7 outputs complement data in approximately 100 μ s and the device then returns to the Read Mode without erasing the data in the block.

DQ6 : Toggle Bit

Toggle bit is another option to detect whether an Internal Routine is in progress or completed. Once the device is at a busy state, DQ6 will toggle. Toggling DQ6 will stop after the device completes its Internal Routine. If the device is in the Erase/Program Suspend Mode, an attempt to read an address that belongs to a block that is being erased or programmed will produce a high output of DQ6. If an address belongs to a block that is not being erased or programmed, toggling is halted and valid data is produced at DQ6. If an attempt is made to program a protected block, DQ6 toggles for approximately 1 μ s and the device then returns to the Read Mode without changing the data in the block. If an attempt is made to erase a protected block, DQ6 toggles for approximately 100 μ s and the device then returns to the Read Mode without erasing the data in the block.

DQ5 : Exceed Timing Limits

If the Internal Program/Erase Routine extends beyond the timing limits, DQ5 will go High, indicating program/erase failure.

DQ3 : Block Erase Timer

The status of the multi-block erase operation can be detected via the DQ3 pin. DQ3 will go High if 50µs of the block erase time window expires. In this case, the Internal Erase Routine will initiate the erase operation. Therefore, the device will not accept further write commands until the erase operation is completed. DQ3 is Low if the block erase time window is not expired. Within the block erase time window, an additional block erase command (30H) can be accepted. To confirm that the block erase command has been accepted, the software may check the status of DQ3 following each block erase command.

DQ2 : Toggle Bit 2

The device generates a toggling pulse in DQ2 only if an Internal Erase Routine or an Erase/Program Suspend is in progress. When the device executes the Internal Erase Routine, DQ2 toggles only if an erasing block is read. Although the Internal Erase Routine is in the Exceeded Time Limits, DQ2 toggles only if an erasing block in the Exceeded Time Limits is read. When the device is in the Erase/Program Suspend mode, DQ2 toggles only if an address in the erasing or programming block is read. If a non-erasing or non-programmed block address is read during the Erase/Program Suspend mode, then DQ2 will produce valid data. DQ2 will go High if the user tries to program a non-erase suspend block while the device is in the Erase Suspend mode.

DQ1 : Buffer Program Abort Indicator

DQ1 indicates whether a Write-to-Buffer operation was aborted. Under these conditions DQ1 produces a "1". The system must issue the Write-to-Buffer-Abort-Reset command sequence to return the device to reading array data.

RDY: Ready

Normally the RDY signal is used to indicate if new burst data is available at the rising edge of the clock cycle or not. If RDY is low state, data is not valid at expected time, and if high state, data is valid. Note that, if CE is low and OE is high, the RDY is high state.

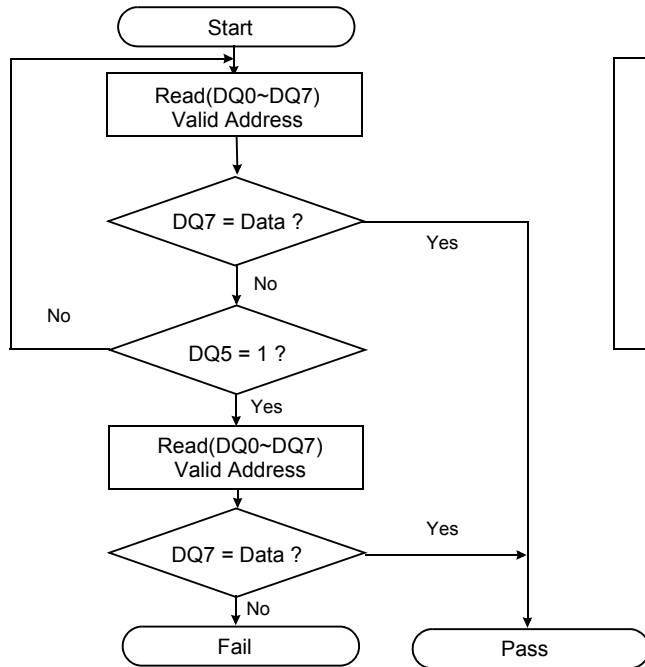

Figure 1. Data Polling Algorithms

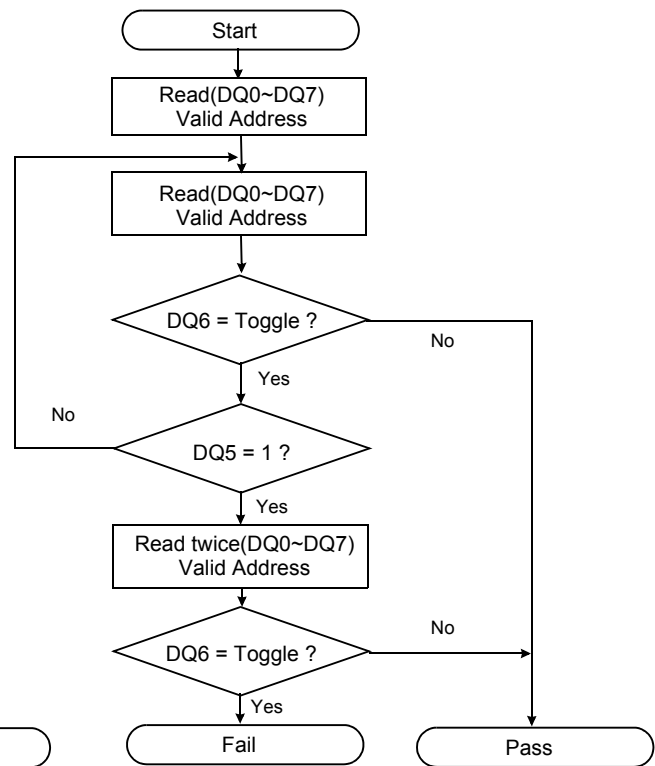

Figure 2. Toggle Bit Algorithms

Deep Power Down

In order to reduce the power consumption of the device, it shall a deep power down mode implemented on a seperate pin. The deep power down mode is active when the deep power down signal is activated, high state. In deep power down the device shall turn off all circuitry in order to reach a power consumption of 2uA(Tpy). The device shall exit the deep power down mode within 75us after that the deep power down signal has been de-activated, set to low. In deep power down the state of the device chip select shall have no impact on the device power consumption. All programming capabilities of the device are inhibited.

At the power up, the device shall accept any order of activation of the reset and deep power down signal. The device shall respond within the specified time for the signal that was deactivated/activated latest. The deep power down mode is activated when DPD pin high state only. If DPD is asserted during a program or erase operation, the device requires a time of tDP(During Internal Routines) before the device is ready to enter DPD mode.

Deep Power Down (DPD)

Parameter	Symbol	All Speed Options			Unit
		Min	Typ	Max	
DPD Pin High(NOT During Internal Routines) to DPD Mode (Note)	tDP	100	-	-	ns
DPD Pin High(During Internal Routines) to DPD Mode (Note)	tDP	20	-	-	μs
DPD Low Time Before Read (Note)	twkup	75	-	-	μs

Note: Not 100% tested.

SWITCHING WAVEFORMS

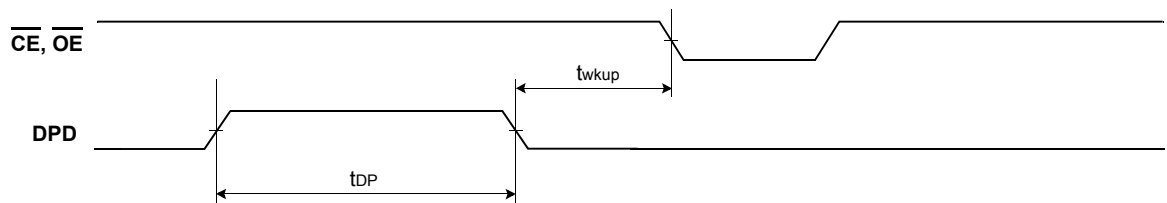

Reset Timings NOT during Internal Routines

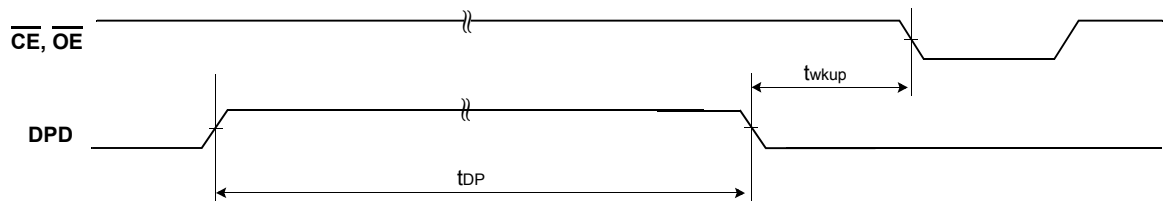

Reset Timings during Internal Routines

Figure 3. DPD Timings

Common Flash Memory Interface

Common Flash Memory Interface is contrived to increase the compatibility of host system software. It provides the specific information of the device, such as memory size and electrical features. Once this information has been obtained, the system software will know which command sets to use to enable flash writes, block erases, and control the flash component.

When the system writes the CFI command(98H) to address 55H, the device enters the CFI mode. And then if the system writes the address shown in Table 11, the system can read the CFI data. Query data are always presented on the lowest-order data outputs(DQ0-7) only. In word(x16) mode, the upper data outputs(DQ8-15) is 00h. To terminate this operation, the system must write the reset command.

Table 11. Common Flash Memory Interface Code

Description	Addresses (Word Mode)	Data
Query Unique ASCII string "QRY"	10H 11H 12H	0051H 0052H 0059H
Primary OEM Command Set	13H 14H	0002H 0000H
Address for Primary Extended Table	15H 16H	0040H 0000H
Alternate OEM Command Set (00h = none exists)	17H 18H	0000H 0000H
Address for Alternate OEM Extended Table (00h = none exists)	19H 1AH	0000H 0000H
Vcc Min. (write/erase) D7-D4: volt, D3-D0: 100 millivolt	1BH	0017H
Vcc Max. (write/erase) D7-D4: volt, D3-D0: 100 millivolt	1CH	0019H
Vpp(Acceleration Program) Supply Minimum 00 = Not Supported, D7 - D4 : Volt, D3 - D0 : 100mV	1DH	0085H
Vpp(Acceleration Program) Supply Maximum 00 = Not Supported, D7 - D4 : Volt, D3 - D0 : 100mV	1EH	0095H
Typical timeout per single word write 2^N us	1FH	0008H
Typical timeout for Max buffer write 2^N us(00H = not supported)	20H	0009H
Typical timeout per individual block erase 2^N ms	21H	000AH
Typical timeout for full chip erase 2^N ms(00H = not supported)	22H	0012H
Max. timeout for word write 2^N times typical	23H	0001H
Max. timeout for buffer write 2^N times typical	24H	0001H
Max. timeout per individual block erase 2^N times typical	25H	0004H
Max. timeout for full chip erase 2^N times typical(00H = not supported)	26H	0000H
Device Size = 2^N byte	27H	0019H
Flash Device Interface description	28H 29H	0000H 0000H
Max. number of byte in multi-byte write = 2^N	2AH 2BH	0006H 0000H
Number of Erase Block Regions within device	2CH	0002H

Table 11. Common Flash Memory Interface Code (Continued)

Description	Addresses (Word Mode)	Data
Erase Block Region 1 Information Bits 0~15: y+1=block number Bits 16~31: block size= z x 256bytes	2DH 2EH 2FH 30H	0003H 0000H 0080H 0000H
Erase Block Region 2 Information	31H 32H 33H 34H	00FEH 0000H 0000H 0002H
Erase Block Region 3 Information	35H 36H 37H 38H	0000H 0000H 0000H 0000H
Erase Block Region 4 Information	39H 3AH 3BH 3CH	0000H 0000H 0000H 0000H
Query-unique ASCII string "PRI"	40H 41H 42H	0050H 0052H 0049H
Major version number, ASCII	43H	0030H
Minor version number, ASCII	44H	0030H
Address Sensitive Unlock(Bits 1-0) 0 = Required, 1= Not Required Silcon Revision Number(Bits 7-2)	45H	0000H
Erase Suspend 0 = Not Supported, 1 = To Read Only, 2 = To Read & Write	46H	0002H
Block Protect 00 = Not Supported, 01 = Supported	47H	0001H
Block Temporary Unprotect 00 = Not Supported, 01 = Supported	48H	0000H
Block Protect/Unprotect scheme 00 = Not Supported, 01 = Supported	49H	0001H
Simultaneous Operation 00 = Not Supported, 01 = Supported	4AH	0001H
Burst Mode Type 00 = Not Supported, 01 = Supported	4BH	0001H
Page Mode Type 00 = Not Supported, 01 = 4 Word Page 02 = 8 Word Page	4CH	0000H
Top/Bottom Boot Block Flag 02H = Bottom Boot Device, 03H = Top Boot Device	4DH	0003H
Max. Operating Clock Frequency (MHz)*	4EH	0085H
RWW(Read While Write) Functionality Restriction (00H = non exists , 01H = exists)	4FH	0000H
Handshaking 00 = Not Supported at both mode, 01 = Supported at Sync. Mode 10 = Supported at Async. Mode, 11 = Supported at both Mode	50H	0001H

* Max. Operating Clock Frequency : Data is 53H in 66/83Mhz part (K8F5615ET(B)M)

ABSOLUTE MAXIMUM RATINGS

Parameter	Symbol	Rating	Unit
Voltage on any pin relative to V _{SS}	V _{CC}	-0.5 to +2.5	V
	V _{PP}	-0.5 to +9.5	
	All Other Pins	-0.5 to +2.5	
Temperature Under Bias	Commercial	-10 to +125	°C
	Extended	-25 to +125	
Storage Temperature	T _{stg}	-65 to +150	°C
Short Circuit Output Current	I _{OS}	5	mA
Operating Temperature	T _A (Commercial Temp.)	0 to +70	°C
	T _A (Extended Temp.)	-25 to +85	°C

Notes :

- Minimum DC voltage is -0.5V on Input/ Output pins. During transitions, this level may fall to -2.0V for periods <20ns.
Maximum DC voltage is V_{CC}+0.6V on input / output pins which, during transitions, may overshoot to V_{CC}+2.0V for periods <20ns.
- Minimum DC input voltage is -0.5V on V_{PP}. During transitions, this level may fall to -2.0V for periods <20ns.
Maximum DC input voltage is +9.5V on V_{PP} which, during transitions, may overshoot to +12.0V for periods <20ns.
- Permanent device damage may occur if ABSOLUTE MAXIMUM RATINGS are exceeded. Functional operation should be restricted to the conditions detailed in the operational sections of this data sheet. Exposure to absolute maximum rating conditions for extended periods may affect reliability.

RECOMMENDED OPERATING CONDITIONS (Voltage reference to GND)

Parameter	Symbol	Min	Typ.	Max	Unit
Supply Voltage	V _{CC}	1.7	1.8	1.95	V
Supply Voltage	V _{SS}	0	0	0	V

DC CHARACTERISTICS

Parameter	Symbol	Test Conditions	Min	Typ	Max	Unit	
Input Leakage Current	I _{LI}	V _{IN} =V _{SS} to V _{CC} , V _{CC} =V _{CCmax}	-1.0	-	+1.0	μA	
V _{PP} Leakage Current	I _{LIP}	V _{CC} =V _{CCmax} , V _{PP} =9.5V	-	-	35	μA	
Output Leakage Current	I _{LO}	V _{OUT} =V _{SS} to V _{CC} , V _{CC} =V _{CCmax} , \overline{OE} =V _{IH}	-1.0	-	+1.0	μA	
Active Burst Read Current	I _{CCB1}	\overline{CE} =V _{IL} , \overline{OE} =V _{IH}	-	66MHz	30	55	mA
Active Asynchronous Read Current	I _{CC1}	\overline{CE} =V _{IL} , \overline{OE} =V _{IH}		10MHz	35	55	mA
				1MHz	8	10	mA
Active Write Current (Note 2)	I _{CC2}	\overline{CE} =V _{IL} , \overline{OE} =V _{IH} , \overline{WE} =V _{IL} , V _{PP} =V _{IH}	-	25	40	mA	
Read While Write Current	I _{CC3}	\overline{CE} =V _{IL} , \overline{OE} =V _{IH}	-	45	70	mA	
Accelerated Program Current	I _{CC4}	\overline{CE} =V _{IL} , \overline{OE} =V _{IH} , V _{PP} =9.5V	-	15	30	mA	
Standby Current	I _{CC5}	\overline{CE} = \overline{RESET} =V _{CC} ± 0.2V	-	30	110	μA	
Standby Current During Reset	I _{CC6}	\overline{RESET} = V _{SS} ± 0.2V	-	30	110	μA	
Automatic Sleep Mode(Note 3)	I _{CC7}	\overline{CE} =V _{SS} ± 0.2V, Other Pins=V _{IL} or V _{IH} V _{IL} = V _{SS} ± 0.2V, V _{IH} = V _{CC} ± 0.2V	-	30	110	μA	
Deep Power Down Mode	I _{CC8}		-	2	20	μA	
Input Low Voltage	V _{IL}		-0.5	-	0.4	V	
Input High Voltage	V _{IH}		V _{CC} -0.4	-	V _{CC} +0.4	V	
Output Low Voltage	V _{OL}	I _{OL} = 100 μA, V _{CC} =V _{CCmin}	-	-	0.1	V	
Output High Voltage	V _{OH}	I _{OH} = -100 μA, V _{CC} =V _{CCmin}	V _{CC} -0.1	-	-	V	
Voltage for Accelerated Program	V _{ID}		8.5	9.0	9.5	V	
Low V _{CC} Lock-out Voltage	V _{LKO}		1.0	-	-	V	
V _{pp} current in program/erase	I _{vpp}	V _{pp} = 9.5V	-	0.8	5	mA	
		V _{pp} = 1.95V	-	-	50	μA	

Notes :

- Maximum ICC specifications are tested with V_{CC} = V_{CCmax}.
- ICC active while Internal Erase or Internal Program is in progress.
- Device enters automatic sleep mode when addresses are stable for t_{AA} + 60ns.

CAPACITANCE (TA = 25 °C, VCC = 1.8V, f = 1.0MHz)

Item	Symbol	Test Condition	Min	Max	Unit
Input Capacitance	CIN	VIN=0V	-	4	pF
Output Capacitance	COU	VOUT=0V	-	6	pF
Control Pin Capacitance	CIN2	VIN=0V	-	4	pF

Note : Capacitance is periodically sampled and not 100% tested.

AC TEST CONDITION

Parameter	Value
Input Pulse Levels	0V to VCC
Input Rise and Fall Times	5ns @66MHz, 5ns @80MHz, 1ns @133MHz
Input and Output Timing Levels	VCC/2
Output Load	CL = 30pF

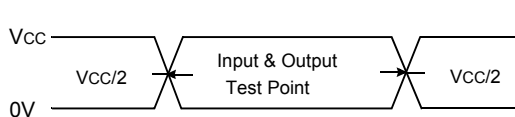

Input Pulse and Test Point

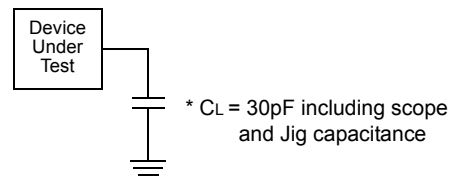

Output Load

AC CHARACTERISTICS Synchronous/Burst Read

Parameter	Symbol	1C (66 MHz)		1D (83 MHz)		1E (108 MHz)		1F (133 MHz)		Unit
		Min	Max	Min	Max	Min	Max	Min	Max	
Initial Access Time	tIAA	-	100	-	100	-	100	-	100	ns
Burst Access Time Valid Clock to Output Delay	tBA	-	11	-	9	-	7	-	6	ns
AVD Setup Time to CLK	tAVDS	5	-	4	-	4	-	2.5	-	ns
AVD Hold Time from CLK	tAVDH	2	-	2	-	2	-	2	-	ns
AVD High to OE Low	tAVDO	0	-	0	-	0	-	0	-	ns
Address Setup Time to CLK	tACS	5	-	4	-	4	-	2.5	-	ns
Address Hold Time from CLK	tACH	6	-	5	-	2	-	2	-	ns
Data Hold Time from Next Clock Cycle	tBDH	3	-	3	-	2	-	2	-	ns
Output Enable to RDY valid	tOER	-	11	-	9	-	7	-	6	ns
CE Disable to High Z	tCEZ	-	15	-	15	-	15	-	15	ns
OE Disable to High Z	tOEZ	-	15	-	15	-	15	-	15	ns
CE Setup Time to CLK	tCES	6	-	6	-	6	-	6	-	ns
CLK to RDY Setup Time	tRDYA	-	11	-	9	-	7	-	6	ns
RDY Setup Time to CLK	tRDYS	3	-	3	-	2	-	2	-	ns
CLK High or Low Time	tCLKH/L	3.5	-	3	-	2.5	-	2.5	-	ns
CLK Fall or Rise Time	tCLKHCL	-	3	-	3	-	2	-	1	ns

Note: Not 100% tested.

SWITCHING WAVEFORMS

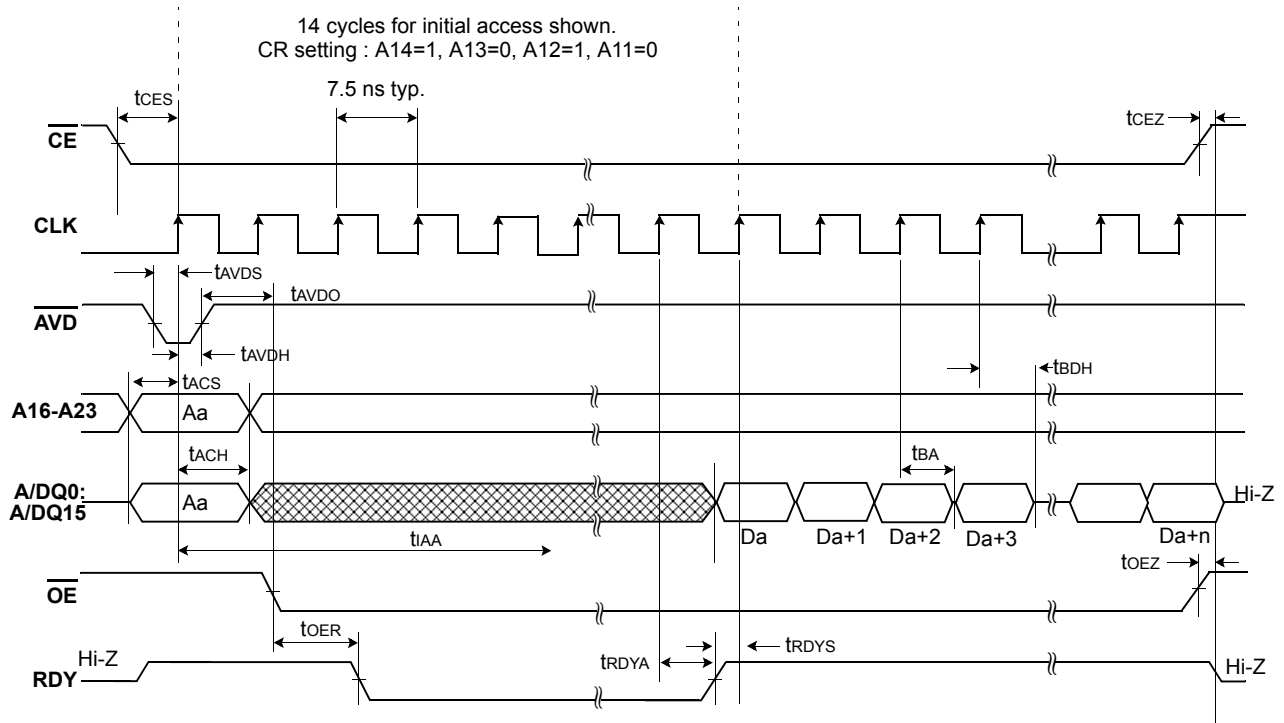

Figure 4. Continuous Burst Mode Read (133 MHz)

Note: In order to avoid a bus conflict the \overline{OE} signal is enabled on the next rising edge after \overline{AVD} is going high.

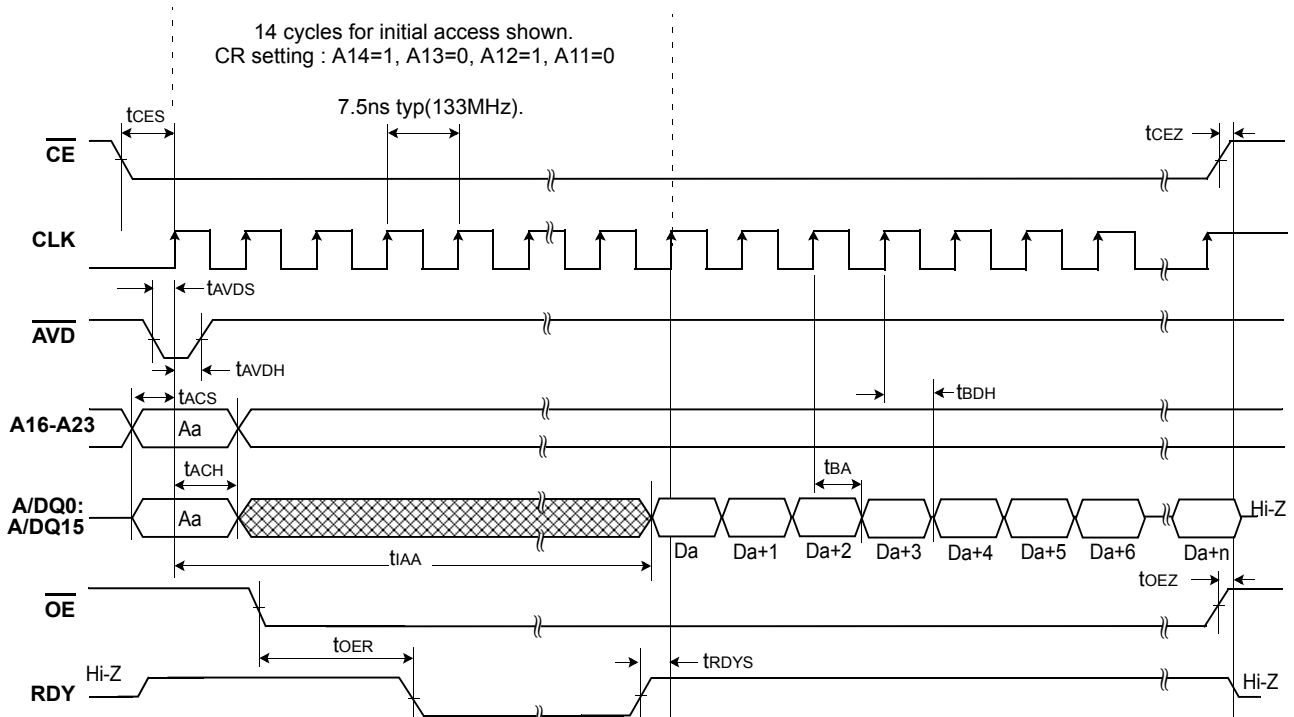

Figure 5. 8 word Linear Burst Mode with Wrap Around (133 MHz)

Note: In order to avoid a bus conflict the \overline{OE} signal is enabled on the next rising edge after \overline{AVD} is going high.

SWITCHING WAVEFORMS

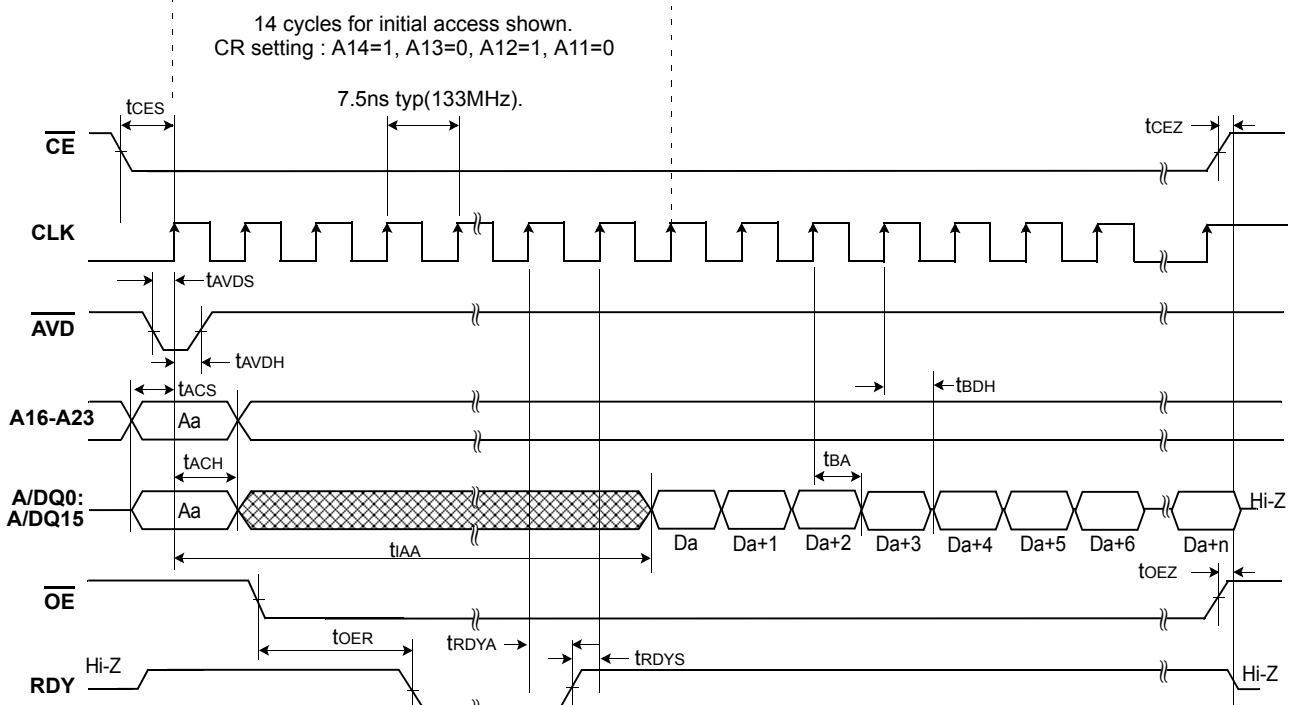

Figure 6. 8 word Linear Burst Mode with RDY Set One Cycle Before Data (Wrap Around, CR setting : A18=1)

Note: In order to avoid a bus conflict the \overline{OE} signal is enabled on the next rising edge after \overline{AVD} is going high.

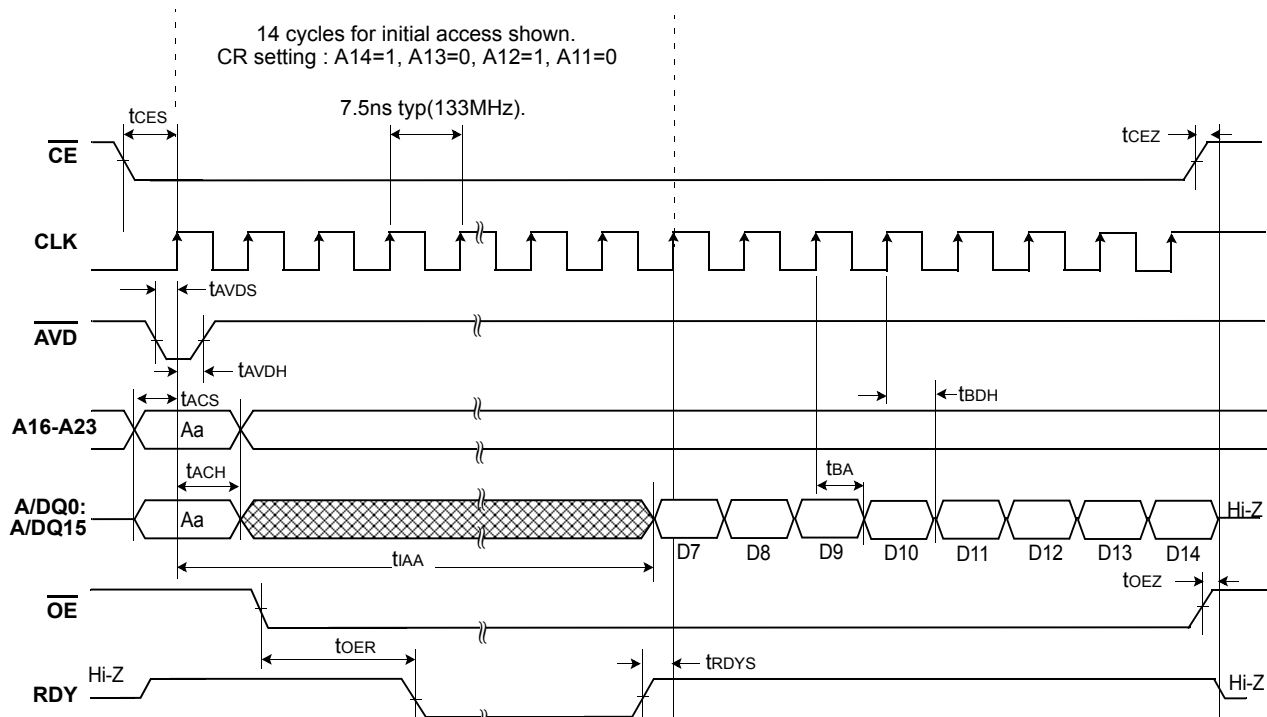

Figure 7. 8 word Linear Burst Mode (No Wrap Case)

Note: In order to avoid a bus conflict the \overline{OE} signal is enabled on the next rising edge after \overline{AVD} is going high.

SWITCHING WAVEFORMS

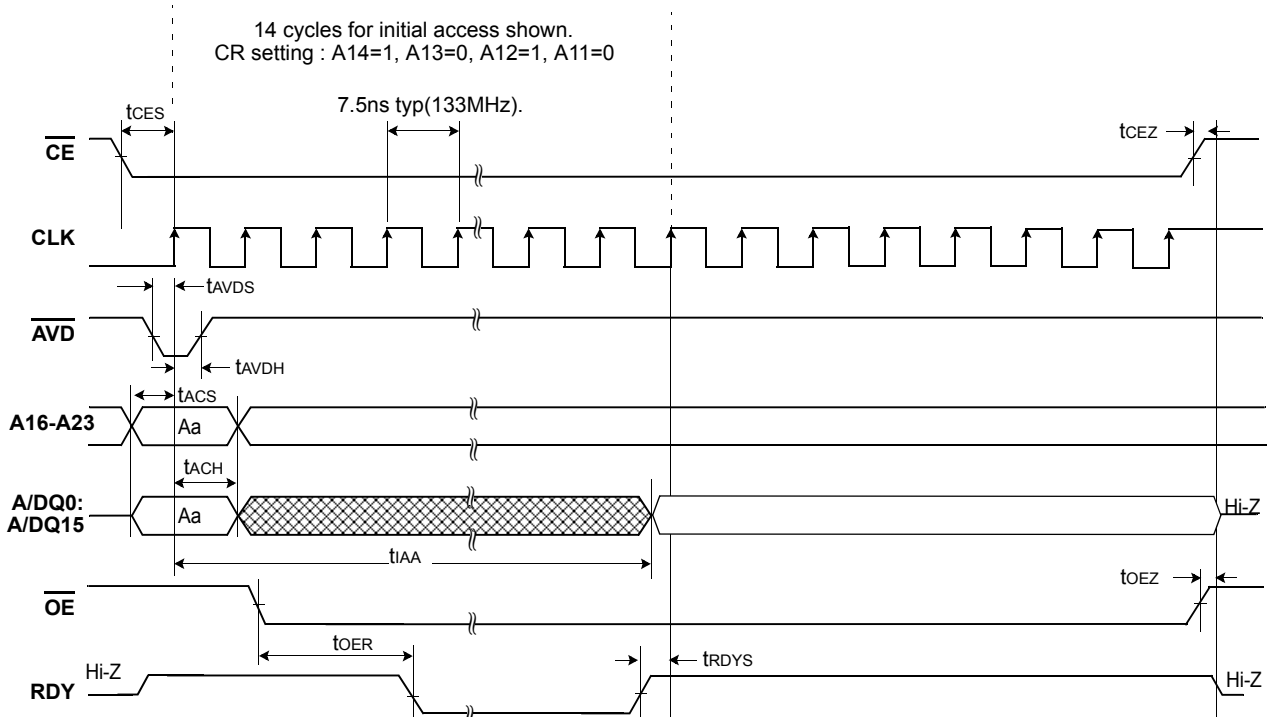

Figure 8. Synchronous Status data read Mode

Note: In order to avoid a bus conflict the \overline{OE} signal is enabled on the next rising edge after \overline{AVD} is going high.

AC CHARACTERISTICS

Asynchronous Read

Parameter	Symbol	1C		1D		1E		1F		Unit
		Min	Max	Min	Max	Min	Max	Min	Max	
Access Time from \overline{CE} Low	t_{CE}	-	100	-	100	-	100	-	100	ns
Asynchronous Access Time	t_{AA}	-	100	-	100	-	100	-	100	ns
\overline{AVD} Low time	t_{AVDP}	12	-	10	-	8	-	7	-	ns
Address Setup Time to rising Edge of AVD	t_{AAVDS}	5	-	4	-	4	-	2.5	-	ns
Address Hold Time from Rising Edge of AVD	t_{AAVDH}	2	-	2	-	2	-	2	-	ns
Output Enable to Output Valid	t_{OE}	-	15	-	15	-	15	-	15	ns
Output Enable Hold Time	Read	0	-	0	-	0	-	0	-	ns
	Toggle and Data Polling	10	-	10	-	10	-	10	-	ns
Output Disable to High Z(Note)	t_{OEZ}	-	15	-	15	-	15	-	15	ns

Note: Not 100% tested.

SWITCHING WAVEFORMS

Asynchronous Mode Read (t_{CE})

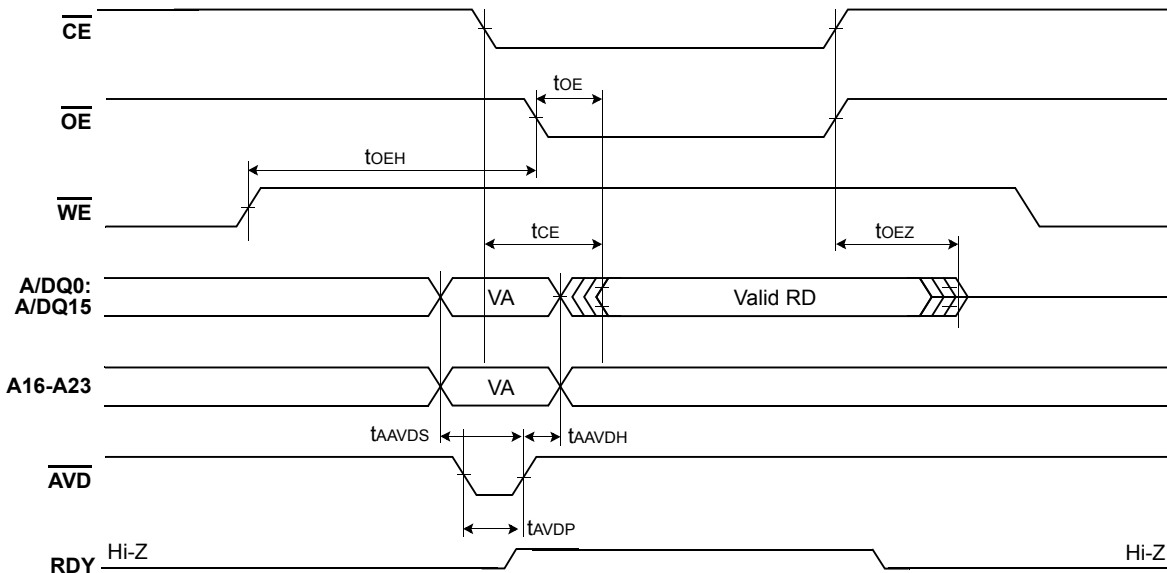

Asynchronous Mode Read (t_{AA})

Case 1 : Valid Address Transition occurs before \overline{AVD} is driven to Low

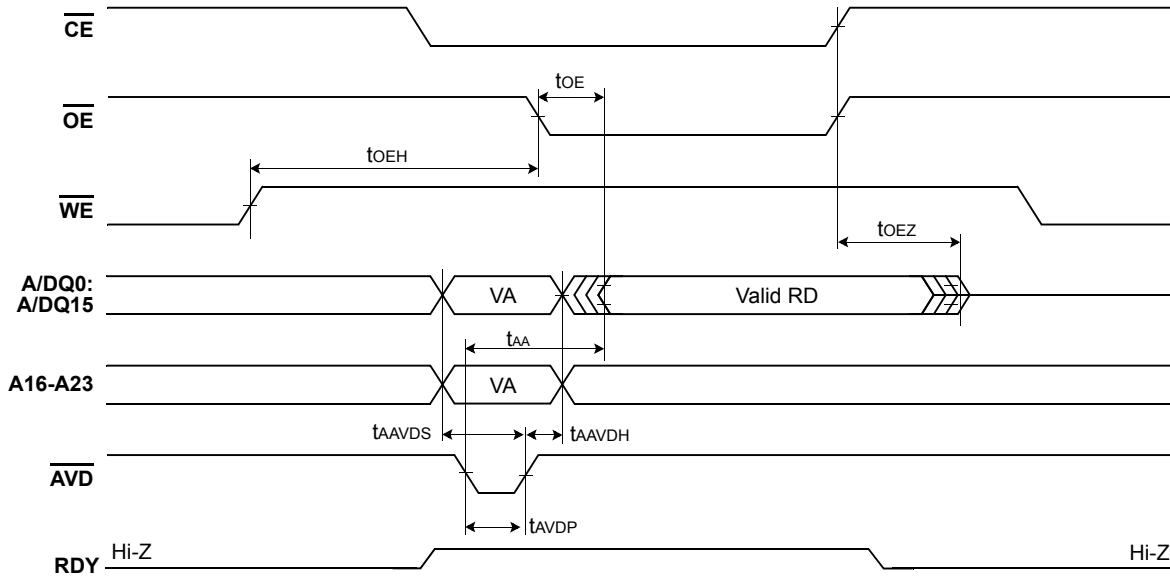

Case 2 : Valid Address Transition occurs after \overline{AVD} is driven to Low

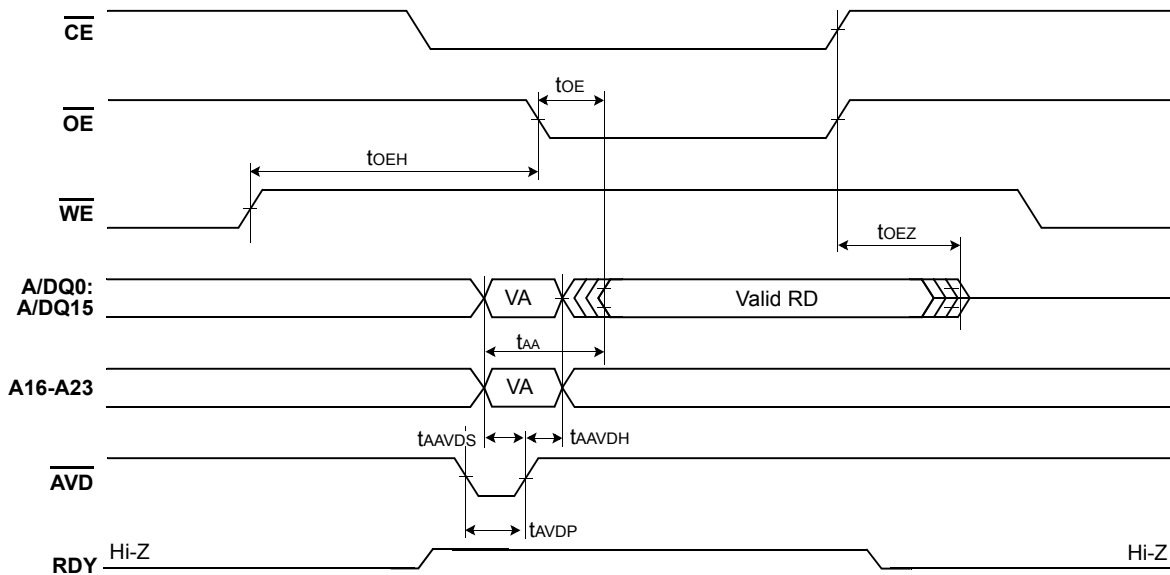

Figure 9. Asynchronous Mode Read

Note: VA=Valid Read Address, RD=Read Data.

Asynchronous mode may not support read following four sequential invalid read condition within 200ns.

AC CHARACTERISTICS

Hardware Reset($\overline{\text{RESET}}$)

Parameter	Symbol	All Speed Options		Unit
		Min	Max	
$\overline{\text{RESET}}$ Pin Low(During Internal Routines) to Read Mode (Note)	t_{Ready}	-	20	μs
$\overline{\text{RESET}}$ Pin Low(NOT During Internal Routines) to Read Mode (Note)	t_{Ready}	-	500	ns
$\overline{\text{RESET}}$ Pulse Width	t_{RP}	200	-	ns
Reset High Time Before Read (Note)	t_{RH}	200	-	ns
$\overline{\text{RESET}}$ Low to Standby Mode	t_{RPD}	20	-	μs

Note: Not 100% tested.

SWITCHING WAVEFORMS

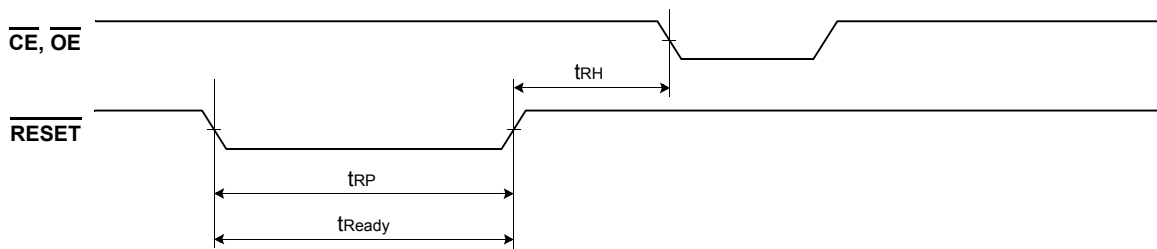

Reset Timings NOT during Internal Routines

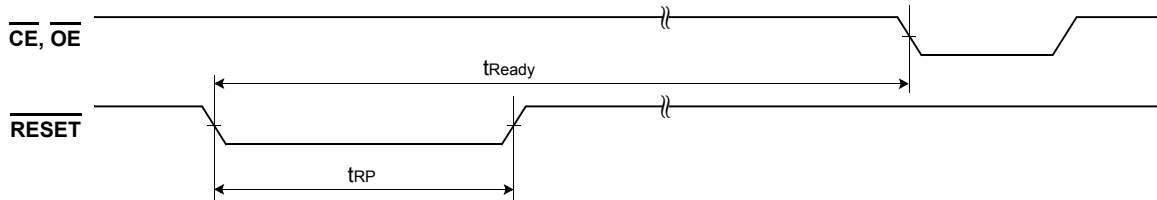

Reset Timings during Internal Routines

Figure 10. Reset Timings

AC CHARACTERISTICS

Erase/Program Operation

Parameter	Symbol	All speed options			Unit
		Min	Typ	Max	
\overline{WE} Cycle Time(Note 1)	t _{WC}	100	-	-	ns
Address Setup Time	t _{AS}	5	-	-	ns
Address Hold Time	t _{AH}	7	-	-	ns
\overline{AVD} Low Time	t _{AVPD}	12	-	-	ns
Data Setup Time	t _{DS}	60	-	-	ns
Data Hold Time	t _{DH}	0	-	-	ns
Read Recovery Time Before Write	t _{GHWL}	0	-	-	ns
\overline{CE} Setup Time	t _{CS}	0	-	-	ns
\overline{CE} Hold Time	t _{CH}	0	-	-	ns
\overline{WE} High to \overline{AVD} low	t _{WEA}	30	-	-	ns
\overline{WE} Pulse Width	t _{WP}	60	-	-	ns
\overline{WE} Pulse Width High	t _{WPH}	40	-	-	ns
Latency Between Read and Write Operations	t _{SRW}	0	-	-	ns
Word Programming Operation (Note 2)	t _{PGM}	-	80	-	μs
Single word Buffer Program (Note 2)	t _{PGM_BP}	-	80	-	μs
32 words Buffer Program (Note 4)	t _{PGM_BP}	-	320	-	μs
Accelerated Programming Operation (Note 3)	t _{ACCPGM}	-	80	-	μs
Accelerated Single word Buffer Program (Note 3)	t _{ACCPGM_BP}	-	80	-	μs
Accelerated 32 words Buffer Program (Note 4)	t _{ACCPGM_BP}	-	128	-	μs
Block Erase Operation	t _{BERS}	-	0.6	-	sec
V _{PP} Rise and Fall Time	t _{VPP}	500	-	-	ns
V _{PP} Setup Time (During Accelerated Programming)	t _{VPS}	1	-	-	μs
V _{CC} Setup Time	t _{VCS}	50	-	-	μs

Notes:

1. Not 100% tested.
2. Internal programming algorithm is optimized for Buffer Program, so Normal word programming or Single word Buffer Program use Buffer Program algorithm.
3. Internal programming algorithm for supporting Accelerated mode uses a method to double the number of words programmed simultaneously.
4. Typical 32-words Buffer Program time pays due regard to that Each program data pattern ("11", "10", "01", "00") has a same portion in 32 words Buffer.

Erase/Program Performance

Parameter		Limits			Unit	Comments		
		Min.	Typ.	Max.				
Block Erase Time	64 Kword	-	0.6	3.0	sec	Includes 00h programming prior to erasure		
	16 Kword	-	0.3	1.5				
Chip Erase Time		-	154	771				
Accelerated Block Erase Time	64 Kword	-	0.4	3.0				
	16 Kword	-	0.2	1.5				
Accelerated Chip Erase Time		-	103	771				
Word Programming Time		-	80	550			μs / word	Excludes system level overhead
32 words Buffer Programming Time		-	10	32				
Accelerated Word Programming Time		-	80	550				
Accelerated 32 words Buffer Programming Time		-	4	22				
Chip Programming Time		-	168	537	sec			
Accelerated Chip Programming Time		-	68	370				

Notes:

1. 25°C, V_{cc} = 1.8V, 100,000 cycles, typical pattern.
2. System-level overhead is defined as the time required to execute the two or four bus cycle command necessary to program each word. In the preprogramming step of the Internal Erase Routine, all words are programmed to 00H before erasure.
3. 100K Program/Erase Cycle in all Bank

SWITCHING WAVEFORMS

Program Operations

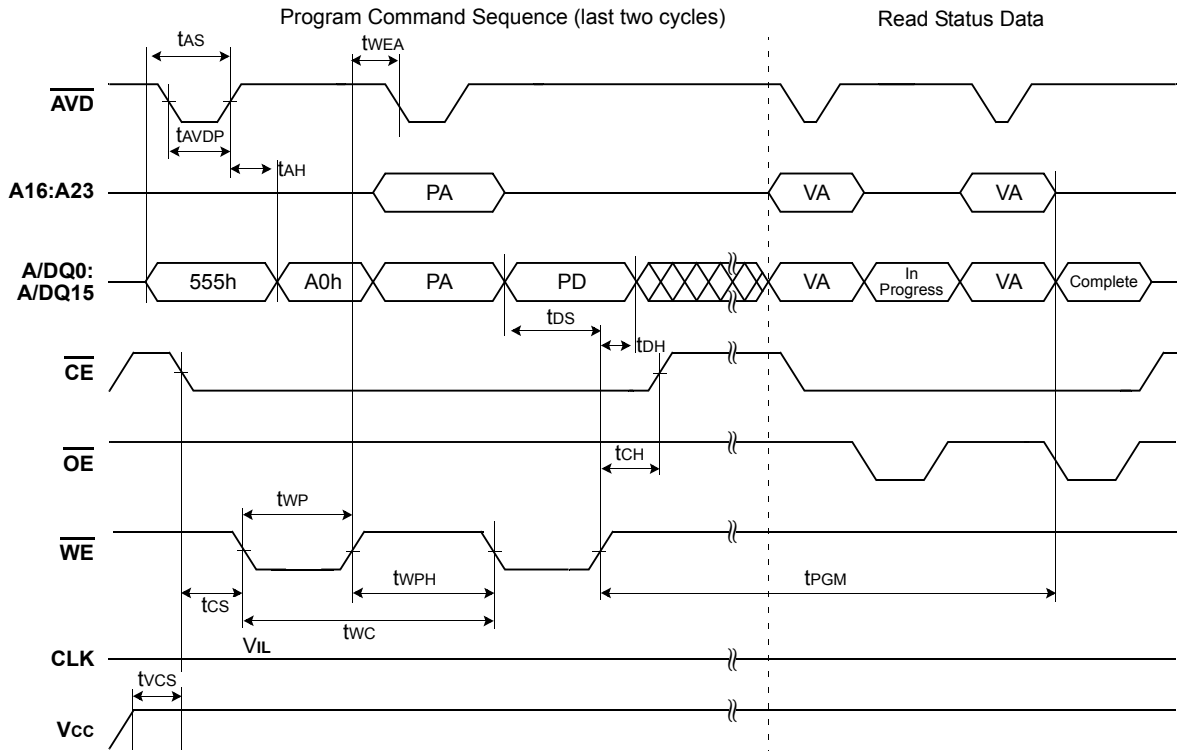

Notes:

1. PA = Program Address, PD = Program Data, VA = Valid Address for reading status bits.
2. "In progress" and "complete" refer to status of program operation.
3. A16–A23 are don't care during command sequence unlock cycles.
4. Status reads in this figure is asynchronous read, but status read in synchronous mode is also supported.

Figure 11. Program Operation Timing

SWITCHING WAVEFORMS

Buffer Program Operations

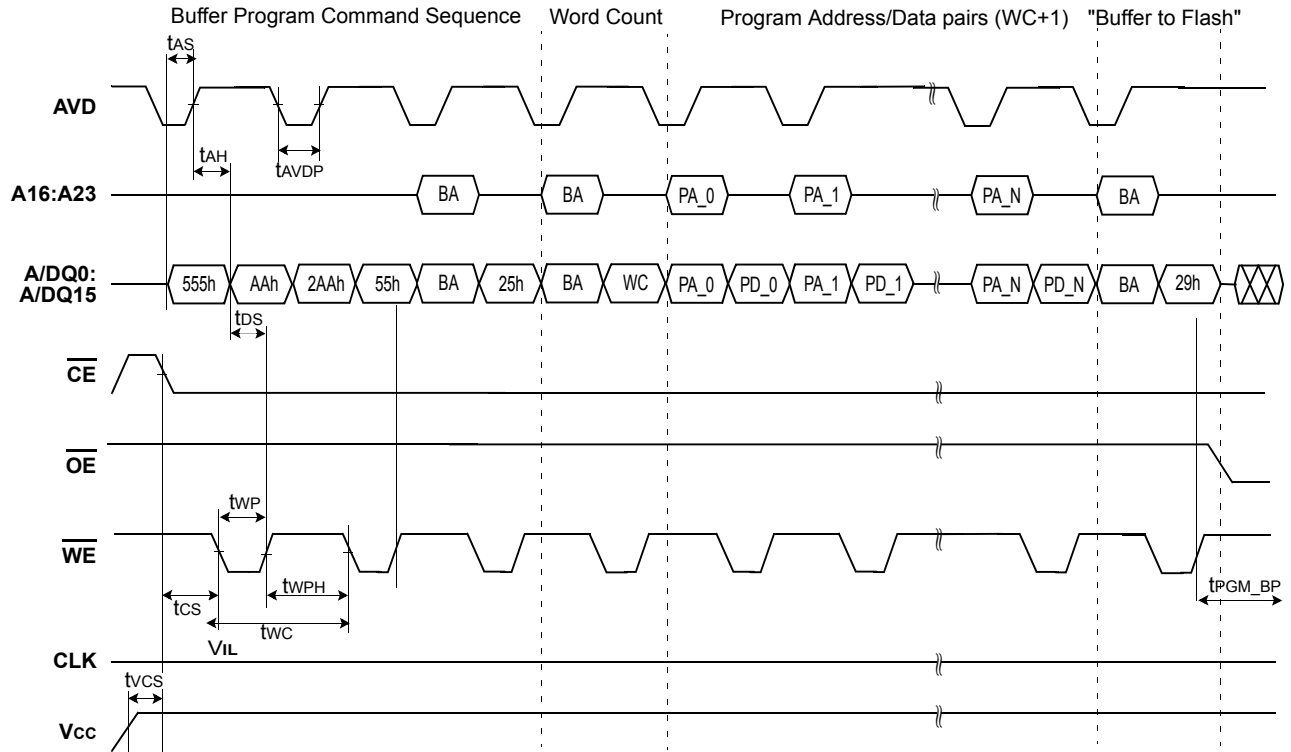

Notes:

1. BA = Block Address, WC = Word Count, PA = Program Address, PD = Program Data, VA = Valid Address for reading status bits.
2. Sequential PA₁, PA₂, ..., PA_N must have same address bits A23(max.) ~ A5 as PA₀ entered firstly
3. The number of Program/Data pairs entered must be same as WC+1 because WC = N.
4. "In progress" and "complete" refer to status of program operation.
5. A16–A23 are don't care during command sequence unlock cycles.
6. Status reads in this figure is asynchronous read, but status read in synchronous mode is also supported.

Figure 12. Buffer Program Operation Timing

SWITCHING WAVEFORMS

Erase Operation

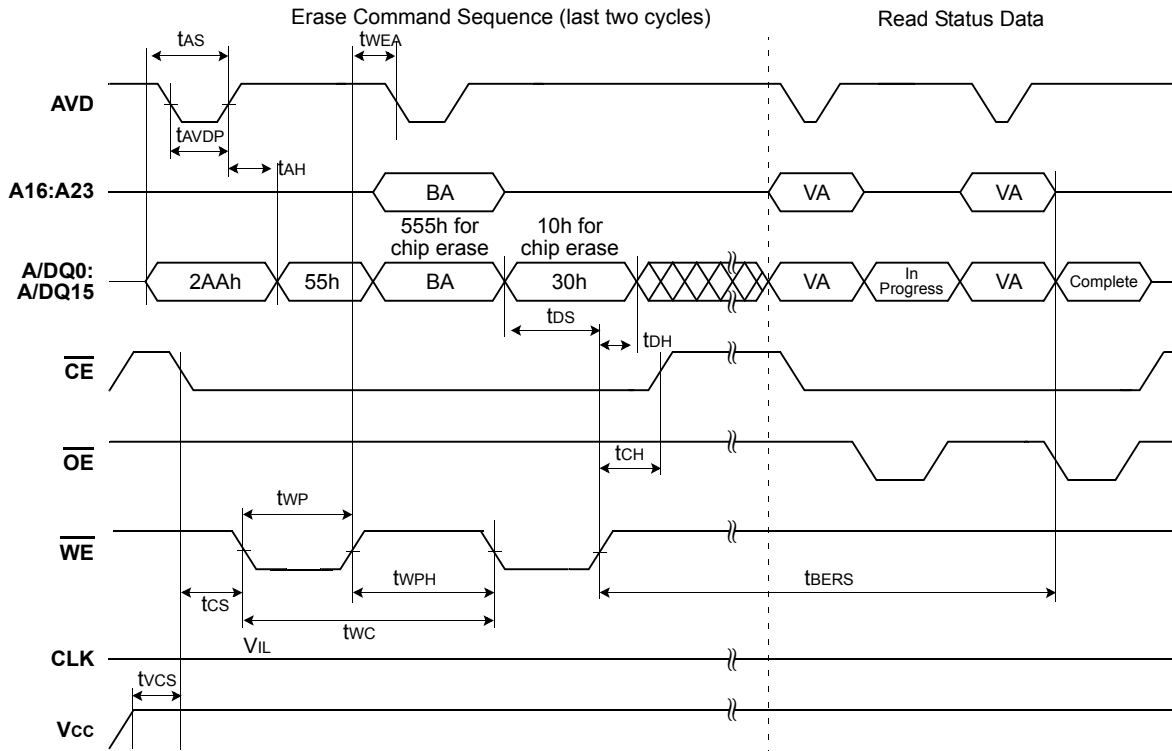

Notes:

1. BA is the block address for Block Erase.
2. Address bits A16–A23 are don't cares during unlock cycles in the command sequence.
3. Status reads in this figure is asynchronous read, but status read in synchronous mode is also supported.

Figure 13. Chlp/Block Erase Operations

SWITCHING WAVEFORMS

Unlock Bypass Program Operations(Accelerated Program)

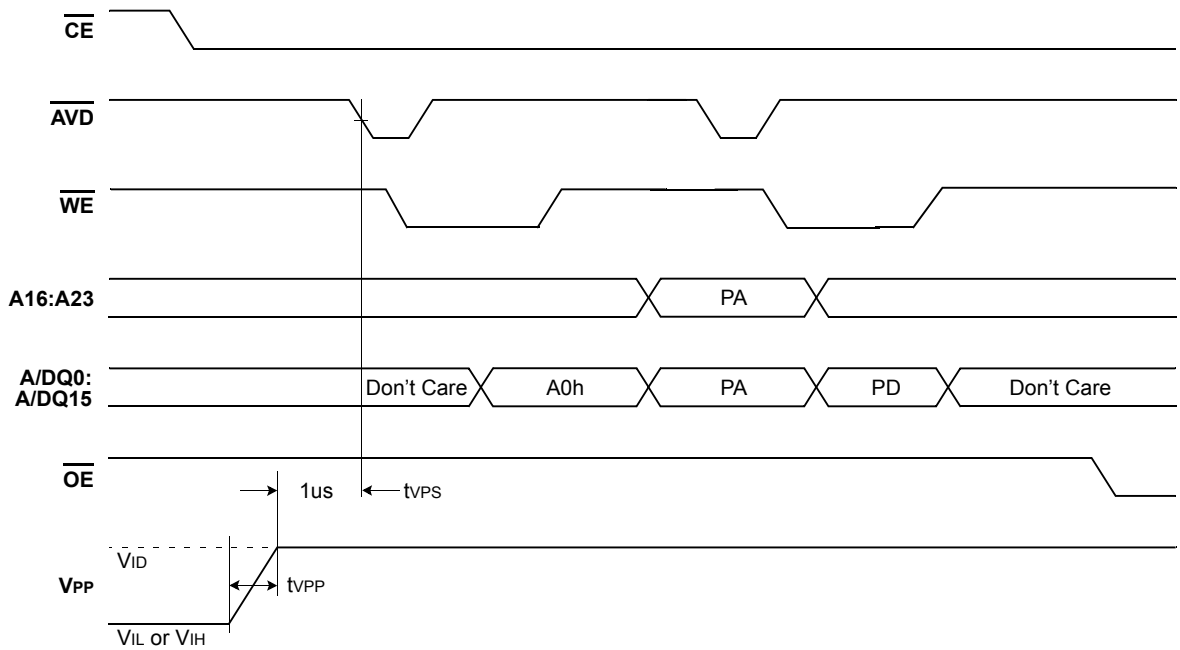

Unlock Bypass Block Erase Operations

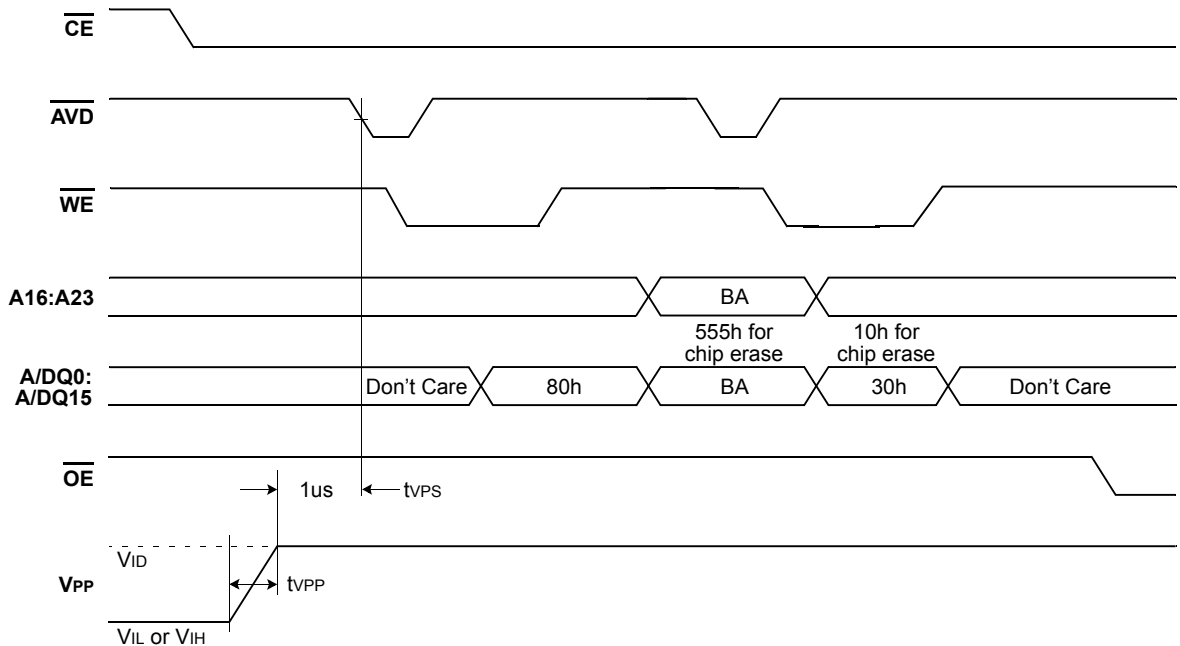

Notes:

1. V_{PP} can be left high for subsequent programming pulses.
2. Use setup and hold times from conventional program operations.
3. Conventional Program/Erase commands as well as Unlock Bypass Program/Erase commands can be used when the V_{ID} is applied to V_{pp} .

Figure 14. Unlock Bypass Operation Timings

SWITCHING WAVEFORMS

Data Polling Operations

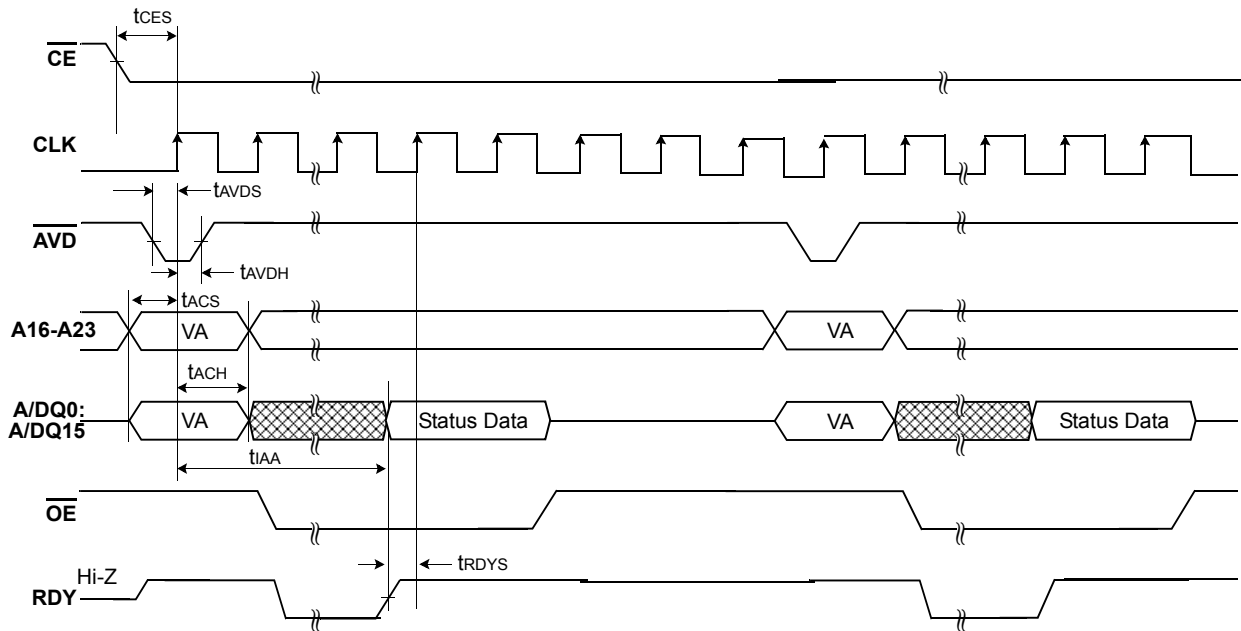

Notes:

1. VA = Valid Address. When the Internal Routine operation is complete, and \overline{Data} Polling will output true data.

Figure 15. Data Polling Timings (During Internal Routine)

Toggle Bit Operations

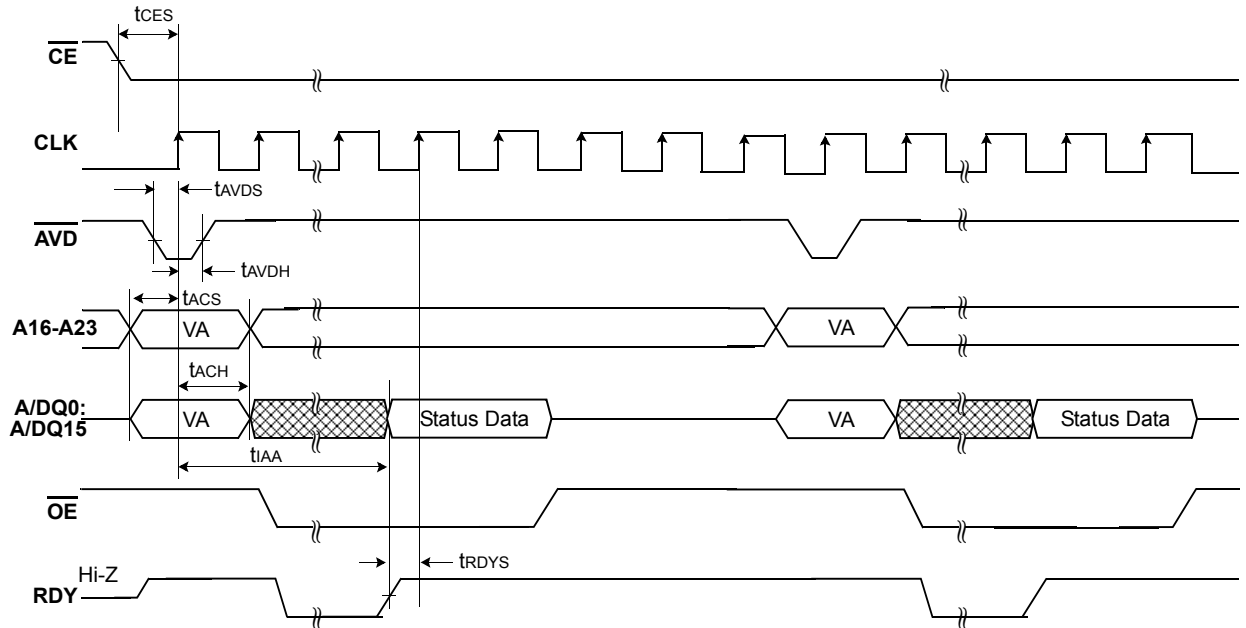

Notes:

1. VA = Valid Address. When the Internal Routine operation is complete, the toggle bits will stop toggling.

Figure 16. Toggle Bit Timings(During Internal Routine)

SWITCHING WAVEFORMS

Read While Write Operations

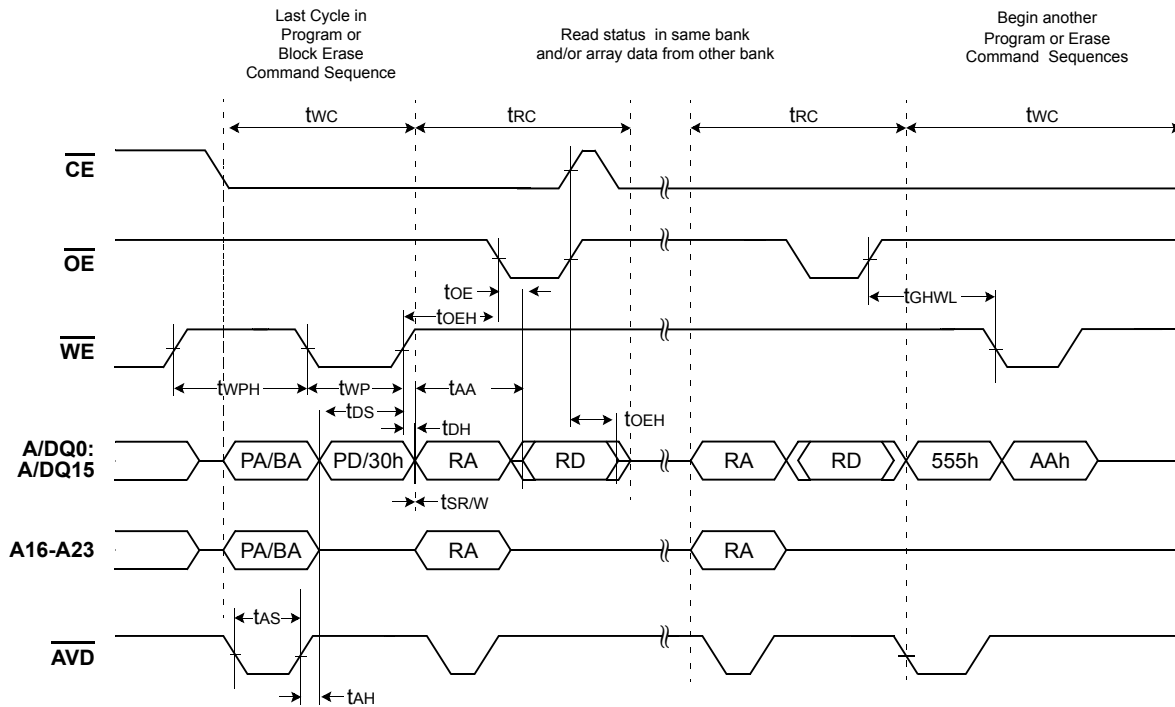

Figure 17. Read While Write Operation

Note:

Breakpoints in waveforms indicate that system may alternately read array data from the "non-busy bank" and checking the status of the program or erase operation in the "busy" bank.

Crossing of First Word Boundary in Burst Read Mode

The additional clock insertion for word boundary is needed only at the first crossing of word boundary. This means that no additional clock cycle is needed from 2nd word boundary crossing to the end of continuous burst read. Also, the number of additional clock cycle for the first word boundary can vary from zero to fourteen cycles, and the exact number of additional clock cycle depends on the starting address of burst read and programmable wait state settings.

For example, if the starting address is $16N+15$ (the worst case) and programmable wait state setting(A<14:11>) is "0011" (which means data is valid on the 7th active CLK edge after \overline{AVD} transition to V_{ih}), six additional clock cycle is needed.

Similarly, if the starting address is $16N+15$ (the worst case) and programmable wait state setting(A<14:11>) is "0010" (which means data is valid on the 6th active CLK edge after \overline{AVD} transition to V_{ih}), five additional clock cycle is needed.

Below table shows the starting address vs. additional clock cycles for first word boundary.

Starting Address vs. Additional Clock Cycles for first word boundary

Starting Address Group for Burst Read	The Residue of (Address/16)	LSB Bits of Address	Additional Clock Cycles for First Word Boundary (note1)				
			A<14:11> "0000" Valid data : 4th CLK	A<14:11> "0001" Valid data : 5th CLK	A<14:11> "0010" Valid data : 6th CLK	...	A<14:11> "1011" Valid data : 15th CLK
16N	0	0000	0 cycle	0 cycle	0 cycle	...	0 cycle
16N+1	1	0001	0 cycle	0 cycle	0 cycle	...	0 cycle
16N+2	2	0010	0 cycle	0 cycle	0 cycle	...	1 cycle
16N+3	3	0011	0 cycle	0 cycle	0 cycle	...	2 cycle
16N+4	4	0100	0 cycle	0 cycle	0 cycle	...	3 cycle
16N+5	5	0101	0 cycle	0 cycle	0 cycle	...	4 cycle
16N+6	6	0110	0 cycle	0 cycle	0 cycle	...	5 cycle
16N+7	7	0111	0 cycle	0 cycle	0 cycle	...	6 cycle
16N+8	8	1000	0 cycle	0 cycle	0 cycle	...	7 cycle
16N+9	9	1001	0 cycle	0 cycle	0 cycle	...	8 cycle
16N+10	10	1010	0 cycle	0 cycle	0 cycle	...	9 cycle
16N+11	11	1011	0 cycle	0 cycle	1 cycle	...	10 cycle
16N+12	12	1100	0 cycle	1 cycle	2 cycle	...	11 cycle
16N+13	13	1101	1 cycle	2 cycle	3 cycle	...	12 cycle
16N+14	14	1110	2 cycle	3 cycle	4 cycle	...	13 cycle
16N+15	15	1111	3 cycle	4 cycle	5 cycle	...	14 cycle

Note 1)

Address bit A<14:11> means the programmable wait state on burst mode configuration register. Refer to Table 7.

Case 1 : Start from "16N" address group

14 cycles for initial access shown.
CR setting : A14=1, A13=0, A12=1, A11=0

7.5ns typ(133MHz).

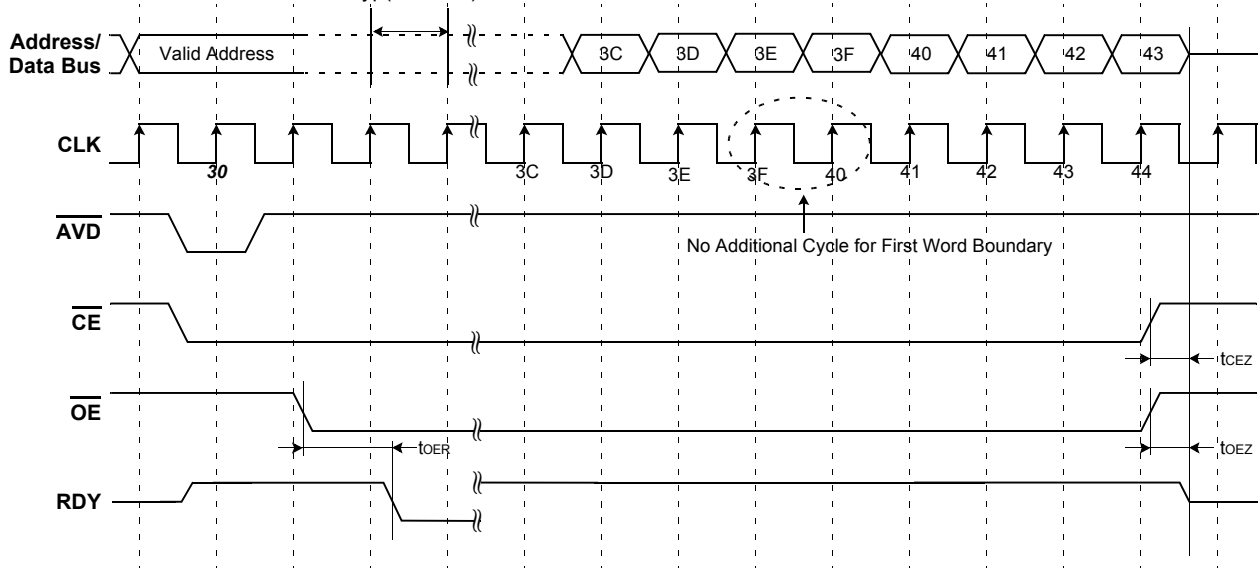

Notes:

1. Address boundary occurs every 16 words beginning at address 00000FH , 00001FH , 00002FH , etc.
2. Address 000000H is also a boundary crossing.
3. No additional clock cycles are needed except for 1st boundary crossing.

Figure 18. Crossing of first word boundary in burst read mode.

Case 2 : Start from "16N+2" address group

14 cycles for initial access shown.
CR setting : A14=1, A13=0, A12=1, A11=0

7.5ns typ(133MHz).

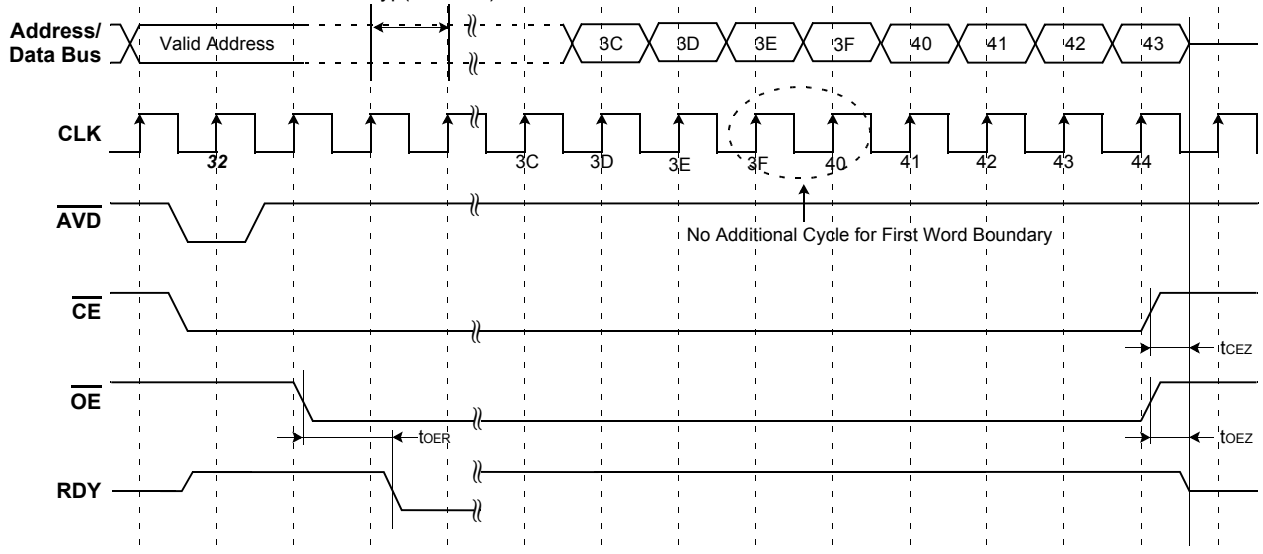

Notes:

1. Address boundary occurs every 16 words beginning at address 00000FH , 00001FH , 00002FH , etc.
2. Address 000000H is also a boundary crossing.
3. No additional clock cycles are needed except for 1st boundary crossing.

Figure 19. Crossing of first word boundary in burst read mode.

Case 3 : Start from "16N+3" address group

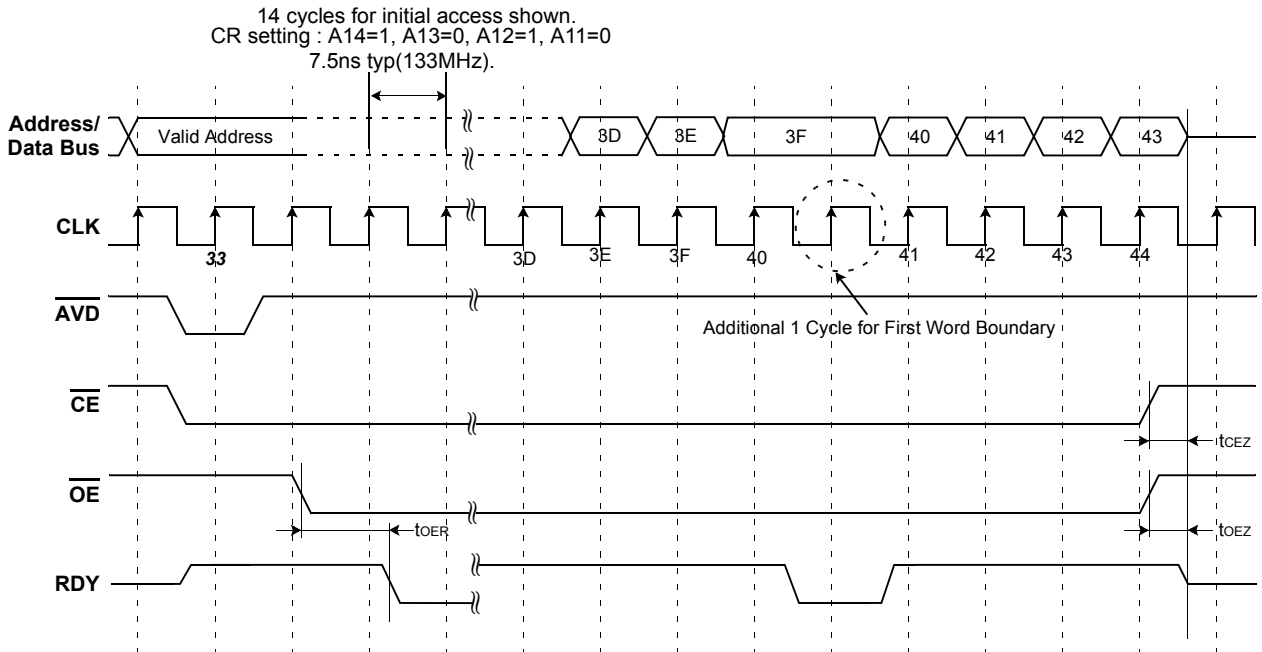

Case 4 : Start from "16N+4" address group

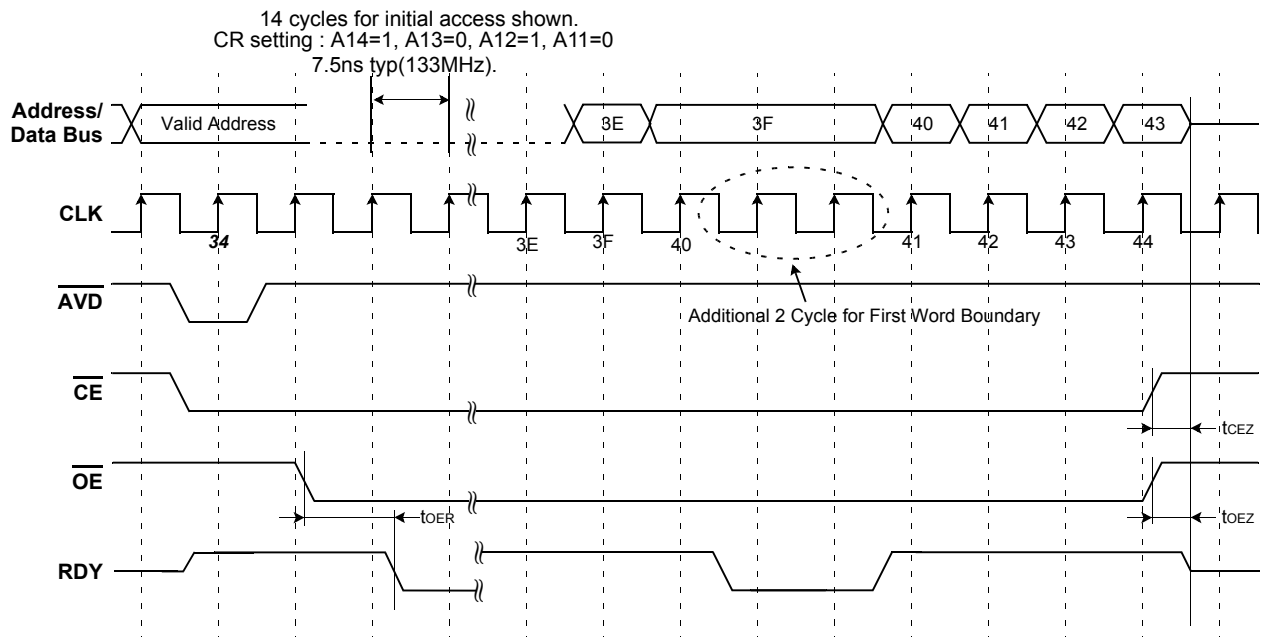

Notes:

1. Address boundary occurs every 16 words beginning at address 00000FH, 00001FH, 00002FH, etc.
2. Address 000000H is also a boundary crossing.
3. No additional clock cycles are needed except for 1st boundary crossing.

Figure 20. Crossing of first word boundary in burst read mode.

Case5 : Start from "16N+15" address group

14 cycles for initial access shown.
 CR setting : A14=1, A13=0, A12=1, A11=0

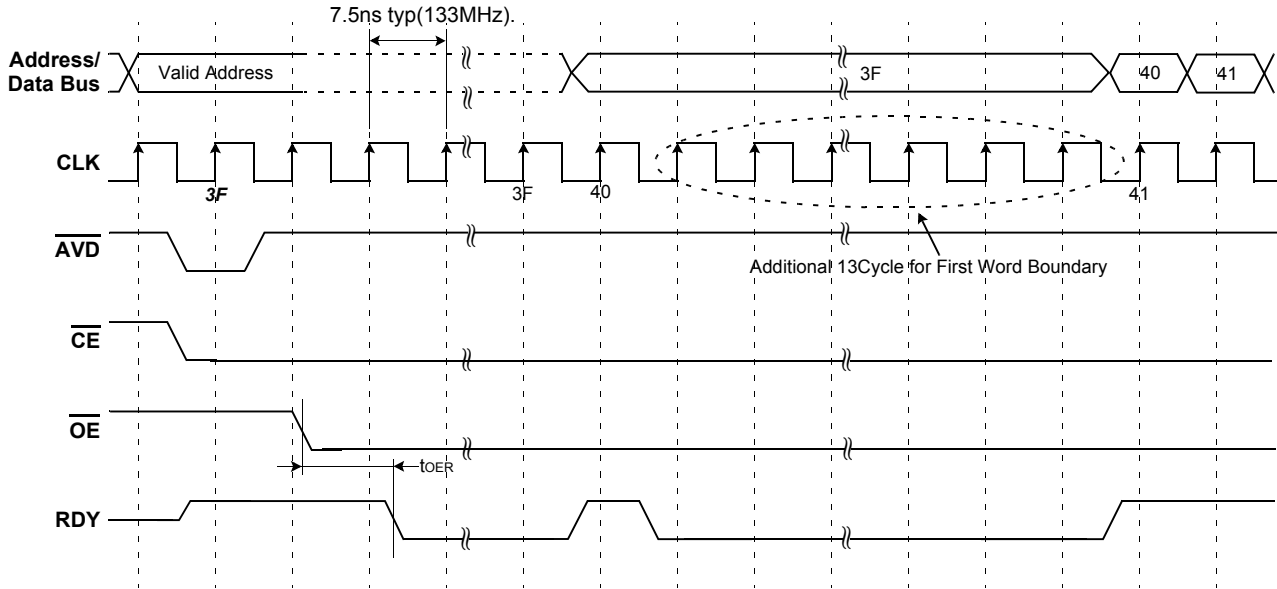

Notes:

1. Address boundry occurs every 16 words beginning at address 00000FH , 00001FH , 00002FH , etc.
2. Address 000000H is also a boundry crossing.
3. No additional clock cycles are needed except for 1st boundary crossing.

Figure 21. Crossing of first word boundary in burst read mode.

88-Ball FBGA Package Dimension and Pin Configuration

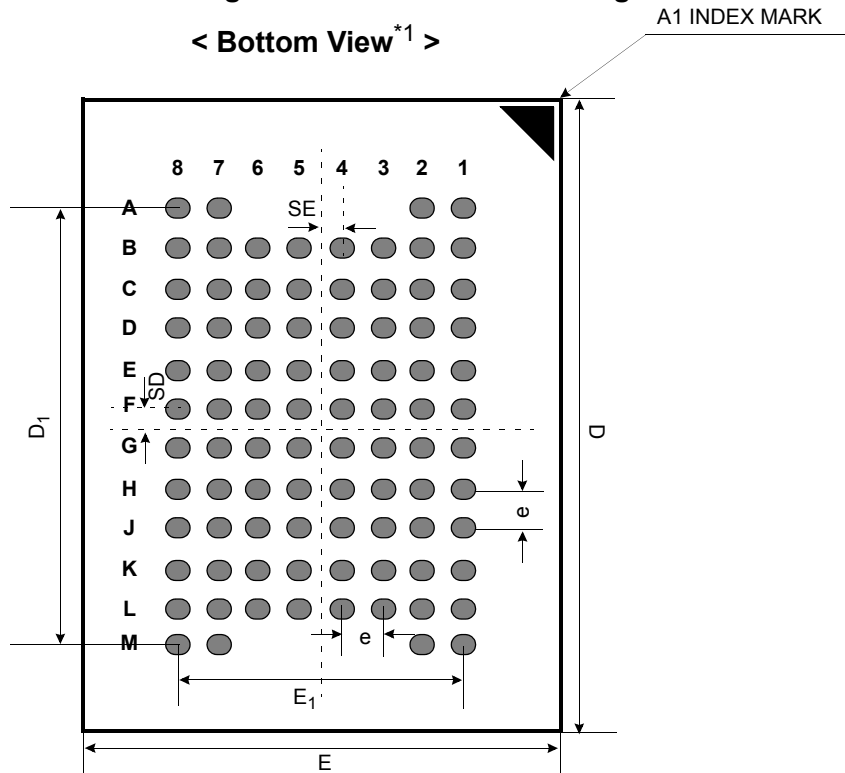

*2: Top View

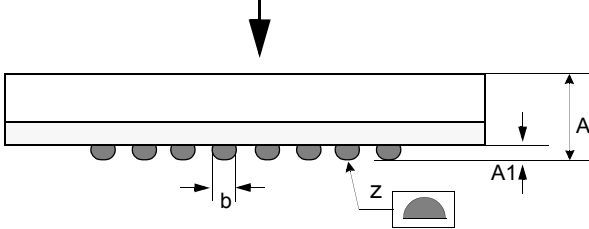

*1: Bottom View

< Top View*2 >

88-Ball (8x11) FBGA								
	1	2	3	4	5	6	7	8
A	DU	DU					DU	DU
B	NC	NC	\overline{WP}	Vss	Vcc	Vcc	NC	NC
C	A20	RFU	NC	Vss	RFU	CLK	DPD	NC
D	NC	A23	RFU	NC	RFU	NC	NC	NC
E	A21	NC	NC	NC	\overline{AVD}	Vpp	A17	A22
F	A16	NC	RFU	\overline{RESET}	\overline{WE}	A19	NC	A18
G	NC	A/DQ7	A/DQ13	A/DQ5	A/DQ10	A/DQ2	RDY	NC
H	RFU	A/DQ15	A/DQ14	A/DQ12	A/DQ3	A/DQ1	A/DQ8	NC
J	RFU	\overline{OE}	A/DQ6	A/DQ4	A/DQ11	A/DQ9	A/DQ0	Vccq
K	\overline{CE}	RFU	RFU	RFU	Vccq	Vcc	Vccq	RFU
L	Vss	Vss	Vccq	Vcc	Vss	Vss	Vss	Vss
M	DU	DU					DU	DU

PIN DESCRIPTION

Pin Name	Pin Function
A16 - A23	Address Inputs
A/DQ0 - A/DQ15	Multiplexed Address/Data input/output
\overline{CE}	Chip Enable
\overline{OE}	Output Enable
\overline{RESET}	Hardware Reset
VPP	Accelerates Programming
\overline{WE}	Write Enable
\overline{WP}	Hardware Write Protection Input
CLK	Clock
RDY	Ready Output
\overline{AVD}	Address Valid Input
DPD	Deep Power Down
Vcc	Power Supply
Vss	Ground

[Unit:mm]



Symbol	Min	Typ	Max
A	-	-	1.20
A ₁	0.25	-	-
E	7.90	8.00	8.10
E ₁	-	5.60	-
D	10.90	11.0	11.10
D ₁	-	8.80	-
e	-	0.80	-
b	0.40	0.45	0.50
z	-	-	0.10
SE	-	0.40	-
SD	-	0.40	-

44-Ball FBGA Package Dimension and Pin Configuration

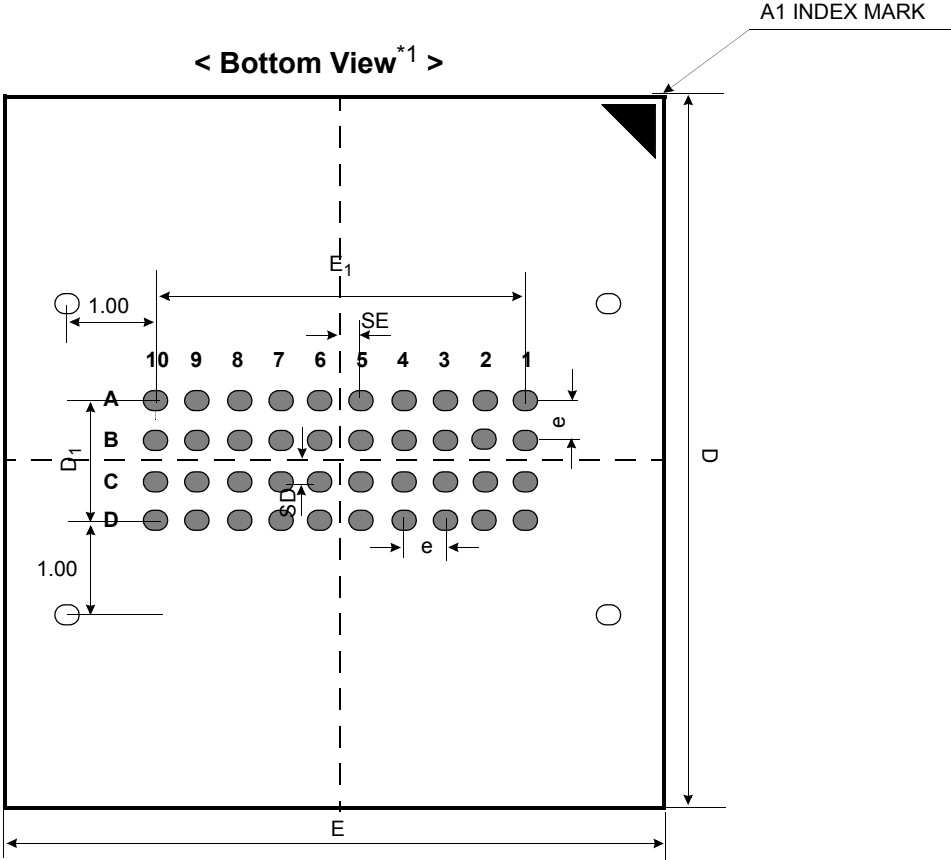

*2: Top View

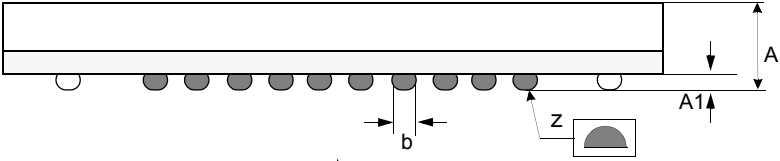

*1: Bottom View

< Top View*2 >

44-Ball (8x9) FBGA										
	1	2	3	4	5	6	7	8	9	10
A	RDY	A21	Vss	CLK	Vcc	\overline{WE}	Vpp	A19	A17	A22
B	Vcc	A16	A20	\overline{AVD}	A23	\overline{RESET}	\overline{WP}	A18	\overline{CE}	Vss
C	Vss	A/DQ7	A/DQ6	A/DQ13	A/DQ12	A/DQ3	A/DQ2	A/DQ9	A/DQ8	\overline{OE}
D	A/DQ15	A/DQ14	Vss	A/DQ5	A/DQ4	A/DQ11	A/DQ10	Vcc	A/DQ1	A/DQ0

PIN DESCRIPTION

Pin Name	Pin Function
A16 - A23	Address Inputs
A/DQ0 - A/DQ15	Multiplexed Address/Data input/output
\overline{CE}	Chip Enable
\overline{OE}	Output Enable
\overline{RESET}	Hardware Reset
VPP	Accelerates Programming
\overline{WE}	Write Enable
\overline{WP}	Hardware Write Protection Input
CLK	Clock
RDY	Ready Output
\overline{AVD}	Address Valid Input
Vcc	Power Supply
Vss	Ground

#A1 Ball Origin Indicator

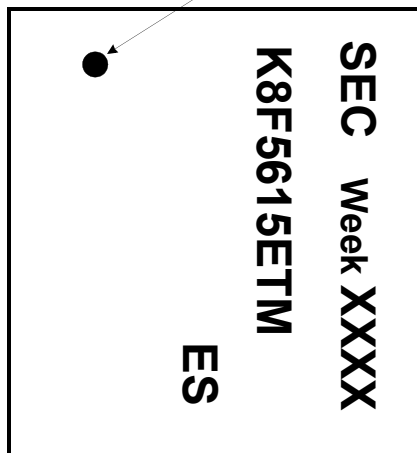

[Unit:mm]

Symbol	Min	Typ	Max
A	-	-	1.00
A ₁	0.15	-	-
E	7.90	8.00	8.10
E ₁	-	4.50	-
D	8.90	9.00	9.10
D ₁	-	1.50	-
e	-	0.50	-
b	0.25	0.30	0.35
z	-	-	0.08
SE	-	0.25	-
SD	-	0.25	-

Table 12-1. Top Boot Block Address Table

Bank	Block	Block Size	(x16) Address Range
Bank 0	BA258	16 Kwords	FFC000h-FFFFFFh
	BA257	16 Kwords	FF8000h-FFBFFFh
	BA256	16 Kwords	FF4000h-FF7FFFh
	BA255	16 Kwords	FF0000h-FF3FFFh
	BA254	64 kwords	FE0000h-FEFFFFh
	BA253	64 kwords	FD0000h-FDFFFFh
	BA252	64 kwords	FC0000h-FCFFFFh
	BA251	64 kwords	FB0000h-FBFFFFh
	BA250	64 kwords	FA0000h-FAFFFFh
	BA249	64 kwords	F90000h-F9FFFFh
	BA248	64 kwords	F80000h-F8FFFFh
	BA247	64 kwords	F70000h-F7FFFFh
	BA246	64 kwords	F60000h-F6FFFFh
	BA245	64 kwords	F50000h-F5FFFFh
	BA244	64 kwords	F40000h-F4FFFFh
	BA243	64 kwords	F30000h-F3FFFFh
Bank 1	BA242	64 kwords	F20000h-F2FFFFh
	BA241	64 kwords	F10000h-F1FFFFh
	BA240	64 kwords	F00000h-F0FFFFh
	BA239	64 kwords	EF0000h-EFFFFFFh
	BA238	64 kwords	EE0000h-EEFFFFh
	BA237	64 kwords	ED0000h-EDFFFFh
	BA236	64 kwords	EC0000h-ECFFFFh
	BA235	64 kwords	EB0000h-EBFFFFh
	BA234	64 kwords	EA0000h-EAFFFFh
	BA233	64 kwords	E90000h-E9FFFFh
	BA232	64 kwords	E80000h-E8FFFFh
	BA231	64 kwords	E70000h-E7FFFFh
	BA230	64 kwords	E60000h-E6FFFFh
	BA229	64 kwords	E50000h-E5FFFFh
	BA228	64 kwords	E40000h-E4FFFFh
	Bank 2	BA227	64 kwords
BA226		64 kwords	E20000h-E2FFFFh
BA225		64 kwords	E10000h-E1FFFFh
BA224		64 kwords	E00000h-E0FFFFh
BA223		64 kwords	DF0000h-DFFFFFh
BA222		64 kwords	DE0000h-DEFFFFh
BA221		64 kwords	DD0000h-DDFFFFh
BA220		64 kwords	DC0000h-DCFFFFh
BA219		64 kwords	DB0000h-DBFFFFh
BA218		64 kwords	DA0000h-DAFFFFh
Bank 2	BA217	64 kwords	D90000h-D9FFFFh
	BA216	64 kwords	D80000h-D8FFFFh
	BA215	64 kwords	D70000h-D7FFFFh
	BA214	64 kwords	D60000h-D6FFFFh

Table 12-1. Top Boot Block Address Table

Bank	Block	Block Size	(x16) Address Range	
Bank 2	BA213	64 kwords	D50000h-D5FFFFh	
	BA212	64 kwords	D40000h-D4FFFFh	
	BA211	64 kwords	D30000h-D3FFFFh	
	BA210	64 kwords	D20000h-D2FFFFh	
	BA209	64 kwords	D10000h-D1FFFFh	
	BA208	64 kwords	D00000h-D0FFFFh	
Bank 3	BA207	64 kwords	CF0000h-CFFFFFFh	
	BA206	64 kwords	CE0000h-CEFFFFFFh	
	BA205	64 kwords	CD0000h-CDFFFFFFh	
	BA204	64 kwords	CC0000h-CCFFFFFFh	
	BA203	64 kwords	CB0000h-CBFFFFFFh	
	BA202	64 kwords	CA0000h-CAFFFFFFh	
	BA201	64 kwords	C90000h-C9FFFFFFh	
	BA200	64 kwords	C80000h-C8FFFFFFh	
	BA199	64 kwords	C70000h-C7FFFFFFh	
	BA198	64 kwords	C60000h-C6FFFFFFh	
	BA197	64 kwords	C50000h-C5FFFFFFh	
	BA196	64 kwords	C40000h-C4FFFFFFh	
	BA195	64 kwords	C30000h-C3FFFFFFh	
	BA194	64 kwords	C20000h-C2FFFFFFh	
	BA193	64 kwords	C10000h-C1FFFFFFh	
	BA192	64 kwords	C00000h-C0FFFFFFh	
	Bank 4	BA191	64 kwords	BF0000h-BFFFFFFh
		BA190	64 kwords	BE0000h-BEFFFFFFh
BA189		64 kwords	BD0000h-BDFFFFFFh	
BA188		64 kwords	BC0000h-BCFFFFFFh	
BA187		64 kwords	BB0000h-BBFFFFFFh	
BA186		64 kwords	BA0000h-BAFFFFFFh	
BA185		64 kwords	B90000h-B9FFFFFFh	
BA184		64 kwords	B80000h-B8FFFFFFh	
BA183		64 kwords	B70000h-B7FFFFFFh	
BA182		64 kwords	B60000h-B6FFFFFFh	
BA181		64 kwords	B50000h-B5FFFFFFh	
BA180		64 kwords	B40000h-B4FFFFFFh	
BA179		64 kwords	B30000h-B3FFFFFFh	
BA178		64 kwords	B20000h-B2FFFFFFh	
Bank 5	BA177	64 kwords	B10000h-B1FFFFFFh	
	BA176	64 kwords	B00000h-B0FFFFFFh	
	BA175	64 kwords	AF0000h-AFFFFFFh	
	BA174	64 kwords	AE0000h-AEFFFFFFh	
	BA173	64 kwords	AD0000h-ADFFFFFFh	
	BA172	64 kwords	AC0000h-ACFFFFFFh	
	BA171	64 kwords	AB0000h-ABFFFFFFh	
BA170	64 kwords	AA0000h-AAFFFFFFh		
BA169	64 kwords	A90000h-A9FFFFFFh		

Table 12-1. Top Boot Block Address Table

Bank	Block	Block Size	(x16) Address Range
Bank 5	BA168	64 kwords	A80000h-A8FFFFh
	BA167	64 kwords	A70000h-A7FFFFh
	BA166	64 kwords	A60000h-A6FFFFh
	BA165	64 kwords	A50000h-A5FFFFh
	BA164	64 kwords	A40000h-A4FFFFh
	BA163	64 kwords	A30000h-A3FFFFh
	BA162	64 kwords	A20000h-A2FFFFh
	BA161	64 kwords	A10000h-A1FFFFh
Bank 6	BA160	64 kwords	A00000h-A0FFFFh
	BA159	64 kwords	9F0000h-9FFFFFh
	BA158	64 kwords	9E0000h-9EFFFFh
	BA157	64 kwords	9D0000h-9DFFFFh
	BA156	64 kwords	9C0000h-9CFFFFh
	BA155	64 kwords	9B0000h-9BFFFFh
	BA154	64 kwords	9A0000h-9AFFFFh
	BA153	64 kwords	990000h-99FFFFh
	BA152	64 kwords	980000h-98FFFFh
	BA151	64 kwords	970000h-97FFFFh
	BA150	64 kwords	960000h-96FFFFh
	BA149	64 kwords	950000h-95FFFFh
	BA148	64 kwords	940000h-94FFFFh
	BA147	64 kwords	930000h-93FFFFh
	BA146	64 kwords	920000h-92FFFFh
	BA145	64 kwords	910000h-91FFFFh
Bank 7	BA144	64 kwords	900000h-90FFFFh
	BA143	64 kwords	8F0000h-8FFFFFh
	BA142	64 kwords	8E0000h-8EFFFFh
	BA141	64 kwords	8D0000h-8DFFFFh
	BA140	64 kwords	8C0000h-8CFFFFh
	BA139	64 kwords	8B0000h-8BFFFFh
	BA138	64 kwords	8A0000h-8AFFFFh
	BA137	64 kwords	890000h-89FFFFh
	BA136	64 kwords	880000h-88FFFFh
	BA135	64 kwords	870000h-87FFFFh
	BA134	64 kwords	860000h-86FFFFh
	BA133	64 kwords	850000h-85FFFFh
	BA132	64 kwords	840000h-84FFFFh
	BA131	64 kwords	830000h-83FFFFh
Bank 8	BA130	64 kwords	820000h-82FFFFh
	BA129	64 kwords	810000h-81FFFFh
	BA128	64 kwords	800000h-80FFFFh
	BA127	64 kwords	7F0000h-7FFFFFh
	BA126	64 kwords	7E0000h-7EFFFFh
	BA125	64 kwords	7D0000h-7DFFFFh
	BA124	64 kwords	7C0000h-7CFFFFh

Table 12-1. Top Boot Block Address Table

Bank	Block	Block Size	(x16) Address Range
Bank 8	BA123	64 kwords	7B0000h-7BFFFFh
	BA122	64 kwords	7A0000h-7AFFFFh
	BA121	64 kwords	790000h-79FFFFh
	BA120	64 kwords	780000h-78FFFFh
	BA119	64 kwords	770000h-77FFFFh
	BA118	64 kwords	760000h-76FFFFh
	BA117	64 kwords	750000h-75FFFFh
	BA116	64 kwords	740000h-74FFFFh
	BA115	64 kwords	730000h-73FFFFh
	BA114	64 kwords	720000h-72FFFFh
	BA113	64 kwords	710000h-71FFFFh
Bank 9	BA112	64 kwords	700000h-70FFFFh
	BA111	64 kwords	6F0000h-6FFFFFh
	BA110	64 kwords	6E0000h-6EFFFFh
	BA109	64 kwords	6D0000h-6DFFFFh
	BA108	64 kwords	6C0000h-6CFFFFh
	BA107	64 kwords	6B0000h-6BFFFFh
	BA106	64 kwords	6A0000h-6AFFFFh
	BA105	64 kwords	690000h-69FFFFh
	BA104	64 kwords	680000h-68FFFFh
	BA103	64 kwords	670000h-67FFFFh
	BA102	64 kwords	660000h-66FFFFh
	BA101	64 kwords	650000h-65FFFFh
	BA100	64 kwords	640000h-64FFFFh
	Bank 10	BA99	64 kwords
BA98		64 kwords	620000h-62FFFFh
BA97		64 kwords	610000h-61FFFFh
BA96		64 kwords	600000h-60FFFFh
BA95		64 kwords	5F0000h-5FFFFFh
BA94		64 kwords	5E0000h-5EFFFFh
BA93		64 kwords	5D0000h-5DFFFFh
BA92		64 kwords	5C0000h-5CFFFFh
BA91		64 kwords	5B0000h-5BFFFFh
BA90		64 kwords	5A0000h-5AFFFFh
BA89		64 kwords	590000h-59FFFFh
BA88		64 kwords	580000h-58FFFFh
BA87		64 kwords	570000h-57FFFFh
BA86		64 kwords	560000h-56FFFFh
BA85		64 kwords	550000h-55FFFFh
BA84		64 kwords	540000h-54FFFFh
BA83		64 kwords	530000h-53FFFFh
BA82	64 kwords	520000h-52FFFFh	
BA81	64 kwords	510000h-51FFFFh	
BA80	64 kwords	500000h-50FFFFh	

Table 12-1. Top Boot Block Address Table

Bank	Block	Block Size	(x16) Address Range
Bank 11	BA79	64 kwords	4F0000h-4FFFFFFh
	BA78	64 kwords	4E0000h-4EFFFFFFh
	BA77	64 kwords	4D0000h-4DFFFFFFh
	BA76	64 kwords	4C0000h-4CFFFFFFh
	BA75	64 kwords	4B0000h-4BFFFFFFh
	BA74	64 kwords	4A0000h-4AFFFFFFh
	BA73	64 kwords	490000h-49FFFFFFh
	BA72	64 kwords	480000h-48FFFFFFh
	BA71	64 kwords	470000h-47FFFFFFh
	BA70	64 kwords	460000h-46FFFFFFh
	BA69	64 kwords	450000h-45FFFFFFh
	BA68	64 kwords	440000h-44FFFFFFh
	BA67	64 kwords	430000h-43FFFFFFh
	BA66	64 kwords	420000h-42FFFFFFh
Bank 12	BA65	64 kwords	410000h-41FFFFFFh
	BA64	64 kwords	400000h-40FFFFFFh
	BA63	64 kwords	3F0000h-3FFFFFFh
	BA62	64 kwords	3E0000h-3EFFFFFFh
	BA61	64 kwords	3D0000h-3DFFFFFFh
	BA60	64 kwords	3C0000h-3CFFFFFFh
	BA59	64 kwords	3B0000h-3BFFFFFFh
	BA58	64 kwords	3A0000h-3AFFFFFFh
	BA57	64 kwords	390000h-39FFFFFFh
	BA56	64 kwords	380000h-38FFFFFFh
	BA55	64 kwords	370000h-37FFFFFFh
	BA54	64 kwords	360000h-36FFFFFFh
	BA53	64 kwords	350000h-35FFFFFFh
	BA52	64 kwords	340000h-34FFFFFFh
Bank 13	BA51	64 kwords	330000h-33FFFFFFh
	BA50	64 kwords	320000h-32FFFFFFh
	BA49	64 kwords	310000h-31FFFFFFh
	BA48	64 kwords	300000h-30FFFFFFh
	BA47	64 kwords	2F0000h-2FFFFFFh
	BA46	64 kwords	2E0000h-2EFFFFFFh
	BA45	64 kwords	2D0000h-2DFFFFFFh
	BA44	64 kwords	2C0000h-2CFFFFFFh
	BA43	64 kwords	2B0000h-2BFFFFFFh
	BA42	64 kwords	2A0000h-2AFFFFFFh
	BA41	64 kwords	290000h-29FFFFFFh
	BA40	64 kwords	280000h-28FFFFFFh
	BA39	64 kwords	270000h-27FFFFFFh
	BA38	64 kwords	260000h-26FFFFFFh
BA37	64 kwords	250000h-25FFFFFFh	
BA36	64 kwords	240000h-24FFFFFFh	
BA35	64 kwords	230000h-23FFFFFFh	

Table 12-1. Top Boot Block Address Table

Bank	Block	Block Size	(x16) Address Range
Bank 13	BA34	64 kwords	220000h-22FFFFh
	BA33	64 kwords	210000h-21FFFFh
	BA32	64 kwords	200000h-20FFFFh
Bank 14	BA31	64 kwords	1F0000h-1FFFFFh
	BA30	64 kwords	1E0000h-1EFFFFh
	BA29	64 kwords	1D0000h-1DFFFFh
	BA28	64 kwords	1C0000h-1CFFFFh
	BA27	64 kwords	1B0000h-1BFFFFh
	BA26	64 kwords	1A0000h-1AFFFFh
	BA25	64 kwords	190000h-19FFFFh
	BA24	64 kwords	180000h-18FFFFh
	BA23	64 kwords	170000h-17FFFFh
	BA22	64 kwords	160000h-16FFFFh
	BA21	64 kwords	150000h-15FFFFh
	BA20	64 kwords	140000h-14FFFFh
	BA19	64 kwords	130000h-13FFFFh
	BA18	64 kwords	120000h-12FFFFh
	BA17	64 kwords	110000h-11FFFFh
Bank 15	BA16	64 kwords	100000h-10FFFFh
	BA15	64 kwords	0F0000h-0FFFFFh
	BA14	64 kwords	0E0000h-0EFFFFh
	BA13	64 kwords	0D0000h-0DFFFFh
	BA12	64 kwords	0C0000h-0CFFFFh
	BA11	64 kwords	0B0000h-0BFFFFh
	BA10	64 kwords	0A0000h-0AFFFFh
	BA9	64 kwords	090000h-09FFFFh
	BA8	64 kwords	080000h-08FFFFh
	BA7	64 kwords	070000h-07FFFFh
	BA6	64 kwords	060000h-06FFFFh
	BA5	64 kwords	050000h-05FFFFh
	BA4	64 kwords	040000h-04FFFFh
	BA3	64 kwords	030000h-03FFFFh
	BA2	64 kwords	020000h-02FFFFh
BA1	64 kwords	010000h-01FFFFh	
BA0	64 kwords	000000h-00FFFFh	

Table 12-1-1. OTP Block Addresses

OTP	Block Address A23 ~ A8	Block Size	(x16) Address Range*
	FFFFh	512words	FFFE00h-FFFFFFh

After entering OTP Block, any issued addresses should be in the range of OTP block address.

Table 12-2. Bottom Boot Block Address Table

Bank	Block	Block Size	(x16) Address Range
Bank 15	BA258	64 Kwords	FF0000h-FFFFFFh
	BA257	64 Kwords	FE0000h-FEFFFFh
	BA256	64 Kwords	FD0000h-FDFFFFh
	BA255	64 Kwords	FC0000h-FCFFFFh
	BA254	64 kwords	FB0000h-FBFFFFh
	BA253	64 kwords	FA0000h-FAFFFFh
	BA252	64 kwords	F90000h-F9FFFFh
	BA251	64 kwords	F80000h-F8FFFFh
	BA250	64 kwords	F70000h-F7FFFFh
	BA249	64 kwords	F60000h-F6FFFFh
	BA248	64 kwords	F50000h-F5FFFFh
	BA247	64 kwords	F40000h-F4FFFFh
	BA246	64 kwords	F30000h-F3FFFFh
	BA245	64 kwords	F20000h-F2FFFFh
	BA244	64 kwords	F10000h-F1FFFFh
Bank 14	BA243	64 kwords	F00000h-F0FFFFh
	BA242	64 kwords	EF0000h-EFFFFFFh
	BA241	64 kwords	EE0000h-EEFFFFh
	BA240	64 kwords	ED0000h-EDFFFFh
	BA239	64 kwords	EC0000h-ECFFFFh
	BA238	64 kwords	EB0000h-EBFFFFh
	BA237	64 kwords	EA0000h-EAFFFFh
	BA236	64 kwords	E90000h-E9FFFFh
	BA235	64 kwords	E80000h-E8FFFFh
	BA234	64 kwords	E70000h-E7FFFFh
	BA233	64 kwords	E60000h-E6FFFFh
	BA232	64 kwords	E50000h-E5FFFFh
	BA231	64 kwords	E40000h-E4FFFFh
	BA230	64 kwords	E30000h-E3FFFFh
	BA229	64 kwords	E20000h-E2FFFFh
Bank 13	BA228	64 kwords	E10000h-E1FFFFh
	BA227	64 kwords	E00000h-E0FFFFh
	BA226	64 kwords	DF0000h-DFFFFFh
	BA225	64 kwords	DE0000h-DEFFFFh
	BA224	64 kwords	DD0000h-DDFFFFh
	BA223	64 kwords	DC0000h-DCFFFFh
	BA222	64 kwords	DB0000h-DBFFFFh
	BA221	64 kwords	DA0000h-DAFFFFh
	BA220	64 kwords	D90000h-D9FFFFh
	BA219	64 kwords	D80000h-D8FFFFh
	BA218	64 kwords	D70000h-D7FFFFh
	BA217	64 kwords	D60000h-D6FFFFh
	BA216	64 kwords	D50000h-D5FFFFh
	BA215	64 kwords	D40000h-D4FFFFh
	BA214	64 kwords	D30000h-D3FFFFh

Table 12-2. Bottom Boot Block Address Table

Bank	Block	Block Size	(x16) Address Range
Bank 13	BA213	64 kwords	D20000h-D2FFFFh
	BA212	64 kwords	D10000h-D1FFFFh
	BA211	64 kwords	D00000h-D0FFFFh
Bank 12	BA210	64 kwords	CF0000h-CFFFFFFh
	BA209	64 kwords	CE0000h-CEFFFFh
	BA208	64 kwords	CD0000h-CDFFFFh
	BA207	64 kwords	CC0000h-CCFFFFh
	BA206	64 kwords	CB0000h-CBFFFFh
	BA205	64 kwords	CA0000h-CAFFFFh
	BA204	64 kwords	C90000h-C9FFFFh
	BA203	64 kwords	C80000h-C8FFFFh
	BA202	64 kwords	C70000h-C7FFFFh
	BA201	64 kwords	C60000h-C6FFFFh
	BA200	64 kwords	C50000h-C5FFFFh
	BA199	64 kwords	C40000h-C4FFFFh
	BA198	64 kwords	C30000h-C3FFFFh
	BA197	64 kwords	C20000h-C2FFFFh
	BA196	64 kwords	C10000h-C1FFFFh
	BA195	64 kwords	C00000h-C0FFFFh
Bank 11	BA194	64 kwords	BF0000h-BFFFFFFh
	BA193	64 kwords	BE0000h-BEFFFFh
	BA192	64 kwords	BD0000h-BDFFFFh
	BA191	64 kwords	BC0000h-BCFFFFh
	BA190	64 kwords	BB0000h-BBFFFFh
	BA189	64 kwords	BA0000h-BAFFFFh
	BA188	64 kwords	B90000h-B9FFFFh
	BA187	64 kwords	B80000h-B8FFFFh
	BA186	64 kwords	B70000h-B7FFFFh
	BA185	64 kwords	B60000h-B6FFFFh
	BA184	64 kwords	B50000h-B5FFFFh
	BA183	64 kwords	B40000h-B4FFFFh
	BA182	64 kwords	B30000h-B3FFFFh
	BA181	64 kwords	B20000h-B2FFFFh
	BA180	64 kwords	B10000h-B1FFFFh
	BA179	64 kwords	B00000h-B0FFFFh
Bank 10	BA178	64 kwords	AF0000h-AFFFFFFh
	BA177	64 kwords	AE0000h-AEFFFFh
	BA176	64 kwords	AD0000h-ADFFFFh
	BA175	64 kwords	AC0000h-ACFFFFh
	BA174	64 kwords	AB0000h-ABFFFFh
	BA173	64 kwords	AA0000h-AAFFFFh
	BA172	64 kwords	A90000h-A9FFFFh
	BA171	64 kwords	A80000h-A8FFFFh
	BA170	64 kwords	A70000h-A7FFFFh
BA169	64 kwords	A60000h-A6FFFFh	

Table 12-2. Bottom Boot Block Address Table

Bank	Block	Block Size	(x16) Address Range
Bank 10	BA168	64 kwords	A50000h-A5FFFFh
	BA167	64 kwords	A40000h-A4FFFFh
	BA166	64 kwords	A30000h-A3FFFFh
	BA165	64 kwords	A20000h-A2FFFFh
	BA164	64 kwords	A10000h-A1FFFFh
	BA163	64 kwords	A00000h-A0FFFFh
Bank 9	BA162	64 kwords	9F0000h-9FFFFFFh
	BA161	64 kwords	9E0000h-9EFFFFh
	BA160	64 kwords	9D0000h-9DFFFFh
	BA159	64 kwords	9C0000h-9CFFFFh
	BA158	64 kwords	9B0000h-9BFFFFh
	BA157	64 kwords	9A0000h-9AFFFFh
	BA156	64 kwords	990000h-99FFFFh
	BA155	64 kwords	980000h-98FFFFh
	BA154	64 kwords	970000h-97FFFFh
	BA153	64 kwords	960000h-96FFFFh
	BA152	64 kwords	950000h-95FFFFh
	BA151	64 kwords	940000h-94FFFFh
	BA150	64 kwords	930000h-93FFFFh
	BA149	64 kwords	920000h-92FFFFh
	BA148	64 kwords	910000h-91FFFFh
	BA147	64 kwords	900000h-90FFFFh
Bank 8	BA146	64 kwords	8F0000h-8FFFFFFh
	BA145	64 kwords	8E0000h-8EFFFFh
	BA144	64 kwords	8D0000h-8DFFFFh
	BA143	64 kwords	8C0000h-8CFFFFh
	BA142	64 kwords	8B0000h-8BFFFFh
	BA141	64 kwords	8A0000h-8AFFFFh
	BA140	64 kwords	890000h-89FFFFh
	BA139	64 kwords	880000h-88FFFFh
	BA138	64 kwords	870000h-87FFFFh
	BA137	64 kwords	860000h-86FFFFh
	BA136	64 kwords	850000h-85FFFFh
	BA135	64 kwords	840000h-84FFFFh
	BA134	64 kwords	830000h-83FFFFh
	BA133	64 kwords	820000h-82FFFFh
BA132	64 kwords	810000h-81FFFFh	
BA131	64 kwords	800000h-80FFFFh	
Bank 7	BA130	64 kwords	7F0000h-7FFFFFFh
	BA129	64 kwords	7E0000h-7EFFFFh
	BA128	64 kwords	7D0000h-7DFFFFh
	BA127	64 kwords	7C0000h-7CFFFFh
	BA126	64 kwords	7B0000h-7BFFFFh
	BA125	64 kwords	7A0000h-7AFFFFh
BA124	64 kwords	790000h-79FFFFh	

Table 12-2. Bottom Boot Block Address Table

Bank	Block	Block Size	(x16) Address Range
Bank 7	BA123	64 kwords	780000h-78FFFFh
	BA122	64 kwords	770000h-77FFFFh
	BA121	64 kwords	760000h-76FFFFh
	BA120	64 kwords	750000h-75FFFFh
	BA119	64 kwords	740000h-74FFFFh
	BA118	64 kwords	730000h-73FFFFh
	BA117	64 kwords	720000h-72FFFFh
	BA116	64 kwords	710000h-71FFFFh
Bank 6	BA115	64 kwords	700000h-70FFFFh
	BA114	64 kwords	6F0000h-6FFFFFh
	BA113	64 kwords	6E0000h-6EFFFFh
	BA112	64 kwords	6D0000h-6DFFFFh
	BA111	64 kwords	6C0000h-6CFFFFh
	BA110	64 kwords	6B0000h-6BFFFFh
	BA109	64 kwords	6A0000h-6AFFFFh
	BA108	64 kwords	690000h-69FFFFh
	BA107	64 kwords	680000h-68FFFFh
	BA106	64 kwords	670000h-67FFFFh
	BA105	64 kwords	660000h-66FFFFh
	BA104	64 kwords	650000h-65FFFFh
	BA103	64 kwords	640000h-64FFFFh
	BA102	64 kwords	630000h-63FFFFh
	BA101	64 kwords	620000h-62FFFFh
	BA100	64 kwords	610000h-61FFFFh
Bank 5	BA99	64 kwords	600000h-60FFFFh
	BA98	64 kwords	5F0000h-5FFFFFh
	BA97	64 kwords	5E0000h-5EFFFFh
	BA96	64 kwords	5D0000h-5DFFFFh
	BA95	64 kwords	5C0000h-5CFFFFh
	BA94	64 kwords	5B0000h-5BFFFFh
	BA93	64 kwords	5A0000h-5AFFFFh
	BA92	64 kwords	590000h-59FFFFh
	BA91	64 kwords	580000h-58FFFFh
	BA90	64 kwords	570000h-57FFFFh
	BA89	64 kwords	560000h-56FFFFh
	BA88	64 kwords	550000h-55FFFFh
	BA87	64 kwords	540000h-54FFFFh
	BA86	64 kwords	530000h-53FFFFh
	BA85	64 kwords	520000h-52FFFFh
	BA84	64 kwords	510000h-51FFFFh
BA83	64 kwords	500000h-50FFFFh	
Bank 4	BA82	64 kwords	4F0000h-4FFFFFh
	BA81	64 kwords	4E0000h-4EFFFFh
	BA80	64 kwords	4D0000h-4DFFFFh

Table 12-2. Bottom Boot Block Address Table

Bank	Block	Block Size	(x16) Address Range
Bank 4	BA79	64 kwords	4C0000h-4CFFFFh
	BA78	64 kwords	4B0000h-4BFFFFh
	BA77	64 kwords	4A0000h-4AFFFFh
	BA76	64 kwords	490000h-49FFFFh
	BA75	64 kwords	480000h-48FFFFh
	BA74	64 kwords	470000h-47FFFFh
	BA73	64 kwords	460000h-46FFFFh
	BA72	64 kwords	450000h-45FFFFh
	BA71	64 kwords	440000h-44FFFFh
	BA70	64 kwords	430000h-43FFFFh
	BA69	64 kwords	420000h-42FFFFh
	BA68	64 kwords	410000h-41FFFFh
	BA67	64 kwords	400000h-40FFFFh
Bank 3	BA66	64 kwords	3F0000h-3FFFFFFh
	BA65	64 kwords	3E0000h-3EFFFFh
	BA64	64 kwords	3D0000h-3DFFFFh
	BA63	64 kwords	3C0000h-3CFFFFh
	BA62	64 kwords	3B0000h-3BFFFFh
	BA61	64 kwords	3A0000h-3AFFFFh
	BA60	64 kwords	390000h-39FFFFh
	BA59	64 kwords	380000h-38FFFFh
	BA58	64 kwords	370000h-37FFFFh
	BA57	64 kwords	360000h-36FFFFh
	BA56	64 kwords	350000h-35FFFFh
	BA55	64 kwords	340000h-34FFFFh
	BA54	64 kwords	330000h-33FFFFh
	BA53	64 kwords	320000h-32FFFFh
	BA52	64 kwords	310000h-31FFFFh
BA51	64 kwords	300000h-30FFFFh	
Bank 2	BA50	64 kwords	2F0000h-2FFFFFFh
	BA49	64 kwords	2E0000h-2EFFFFh
	BA48	64 kwords	2D0000h-2DFFFFh
	BA47	64 kwords	2C0000h-2CFFFFh
	BA46	64 kwords	2B0000h-2BFFFFh
	BA45	64 kwords	2A0000h-2AFFFFh
	BA44	64 kwords	290000h-29FFFFh
	BA43	64 kwords	280000h-28FFFFh
	BA42	64 kwords	270000h-27FFFFh
	BA41	64 kwords	260000h-26FFFFh
	BA40	64 kwords	250000h-25FFFFh
	BA39	64 kwords	240000h-24FFFFh
	BA38	64 kwords	230000h-23FFFFh
	BA37	64 kwords	220000h-22FFFFh
BA36	64 kwords	210000h-21FFFFh	
BA35	64 kwords	200000h-20FFFFh	

Table 12-2. Bottom Boot Block Address Table

Bank	Block	Block Size	(x16) Address Range	
Bank 1	BA34	64 kwords	1F0000h-1FFFFFFh	
	BA33	64 kwords	1E0000h-1EFFFFFFh	
	BA32	64 kwords	1D0000h-1DFFFFFFh	
	BA31	64 kwords	1C0000h-1CFFFFFFh	
	BA30	64 kwords	1B0000h-1BFFFFFFh	
	BA29	64 kwords	1A0000h-1AFFFFFFh	
	BA28	64 kwords	190000h-19FFFFFFh	
	BA27	64 kwords	180000h-18FFFFFFh	
	BA26	64 kwords	170000h-17FFFFFFh	
	BA25	64 kwords	160000h-16FFFFFFh	
	BA24	64 kwords	150000h-15FFFFFFh	
	BA23	64 kwords	140000h-14FFFFFFh	
	BA22	64 kwords	130000h-13FFFFFFh	
	BA21	64 kwords	120000h-12FFFFFFh	
	BA20	64 kwords	110000h-11FFFFFFh	
	BA19	64 kwords	100000h-10FFFFFFh	
	Bank 0	BA18	64 kwords	0F0000h-0FFFFFFh
		BA17	64 kwords	0E0000h-0EFFFFFFh
BA16		64 kwords	0D0000h-0DFFFFFFh	
BA15		64 kwords	0C0000h-0CFFFFFFh	
BA14		64 kwords	0B0000h-0BFFFFFFh	
BA13		64 kwords	0A0000h-0AFFFFFFh	
BA12		64 kwords	090000h-09FFFFFFh	
BA11		64 kwords	080000h-08FFFFFFh	
BA10		64 kwords	070000h-07FFFFFFh	
BA9		64 kwords	060000h-06FFFFFFh	
BA8		64 kwords	050000h-05FFFFFFh	
BA7		64 kwords	040000h-04FFFFFFh	
BA6		64 kwords	030000h-03FFFFFFh	
BA5		64 kwords	020000h-02FFFFFFh	
BA4		64 kwords	010000h-01FFFFFFh	
BA3		16 kwords	00C000h-00FFFFFFh	
BA2		16 kwords	008000h-00BFFFFh	
BA1		16 kwords	004000h-007FFFFh	
BA0	16 kwords	000000h-003FFFFh		

Table 12-2-1. OTP Block Addresses

OTP	Block Address A23 ~ A8	Block Size	(x16) Address Range*
	0000h	512 words	000000h-0001FFFh

After entering OTP Block, any issued addresses should be in the range of OTP block address.