



AK8777B

Hall Effect IC for Pulse Encoders

Overview

The AK8777B is a Hall effect latch which detects both “vertical” and “horizontal”(perpendicular and parallel to the marking side of the package) magnetic field at the same time. The output OUTA and OUTB are switched according to the vertical and horizontal magnetic fields applied to the device. The AK8777B is for use in the incremental pulse encoders or rotational detection systems.

Features

- 4.0 to 24V supply voltage operation
- Sensitivity (Vertical, Horizontal) : $\pm 1.7\text{mT}$ (Typ.)
- Two outputs : OUTA (detects vertical magnetic field), OUTB (detects horizontal magnetic field)
- Small package: SOP-6pin
- Halogen free

Block Diagram

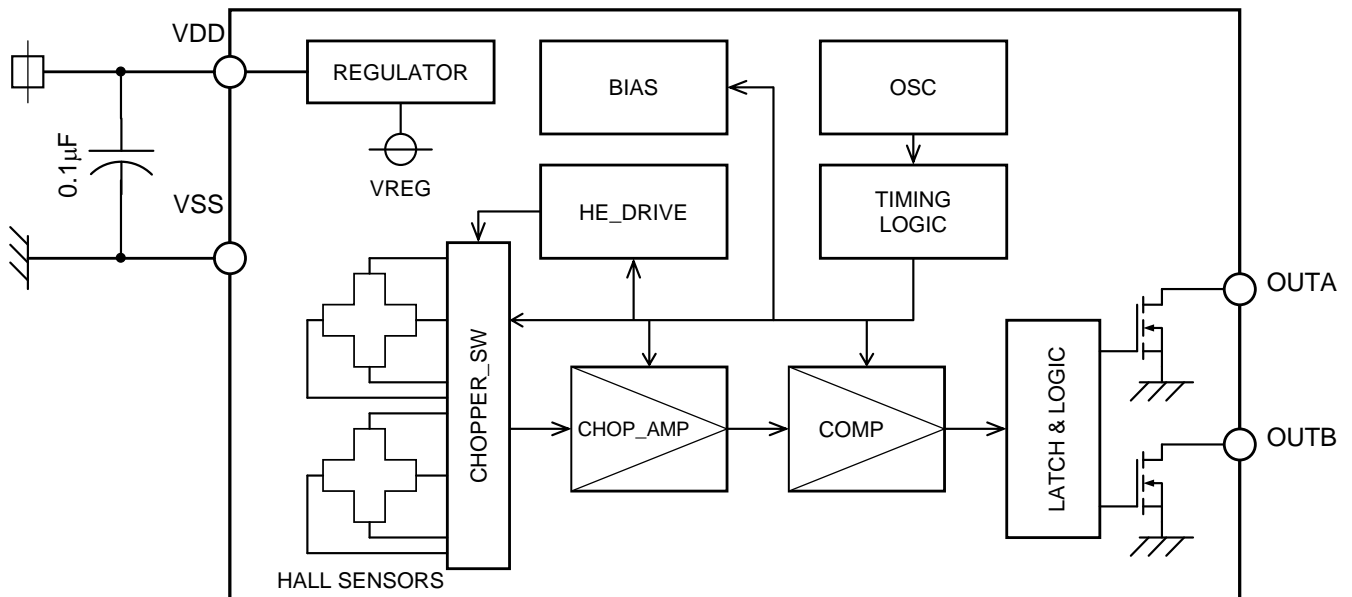

Figure 1. Block diagram

Circuit Configuration

Table 1. Circuit configuration

Block	Function
REGULATOR	Generate internal operating voltage.
HALL SENSORS	Two Hall elements fabricated by CMOS process.
CHOPPER_SW	Perform chopping in order to cancel the offset of Hall sensor.
CHOP_AMP	Amplifies two Hall sensor output voltage with summation and subtraction circuit.
COMP	Hysteresis comparator.
BIAS	Generates bias current to internal circuits.
HE_DRIVE	Generates bias current for Hall sensors.
OSC	Generates operating clock.
TIMING LOGIC	Generates timing signal for internal circuits.
LATCH & LOGIC	Logical circuits and open drain driver.

Pin/Function

Table 2. Description of pin name and function

Pin No.	Pin name	I/O	Function	Note
1	VDD		Power supply pin	
2	TAB		(TAB pin)	
3	OUTA	O	Output A pin. Relating to the vertical magnetic field.	Open drain
4	OUTB	O	Output B pin. Relating to the horizontal magnetic field.	Open drain
5	TAB		(TAB pin)	
6	VSS		Ground pin	

Note) TAB pins should be connected to VSS.

Absolute Maximum Ratings

Table 3. Absolute maximum ratings

Parameter	Symbol	Min.	Max.	Unit	Note
Supply voltage	V_{DD}	-0.3	+32	V	VSS=0V
Output voltage	V_{OUT}	-0.3	+32	V	OUTA,OUTB pin VSS=0V
Output current	I_{OUT}		20	mA	OUTA,OUTB pin
Storage temperature	T_{STG}	-55	+150	°C	

Note) Stress beyond these listed values may cause permanent damage to the device.

Recommended Operating Conditions

Table 4. Recommended operating conditions

Parameter	Symbol	Min.	Typ.	Max.	Unit
Supply voltage	V_{DD}	4.0	12.0	24.0	V
Output current	I_{SINK}			15	mA
Operating temperature	T_a	-40		+125	°C

Electrical Characteristics

Table 5. Electrical characteristics at $V_{DD}=4.0$ to $24.0V$, $T_a=-40$ to $+125^{\circ}C$

Parameter	Symbol	Min.	Typ.	Max.	Unit	Note
Current consumption	I_{DD}	1.4	3.0	5.6	mA	
Output saturation voltage	V_{SAT}			0.4	V	OUTA, OUTB pin, $I_{SINK}=15mA$
Output leak current	I_{LEAK}			10	μA	OUTA, OUTB = V_{DD}
Output refresh period	T_P	12.0	16.7	30.5	μs	

Magnetic Characteristics

Table 6. Magnetic characteristics at $V_{DD}=4.0$ to $24.0V$, $T_a=-40$ to $+125^{\circ}C$

Parameter	Symbol	Min.	Typ.	Max.	Unit	Note
Operating point of vertical magnetic field	BopV	0.1	1.7	4.0	mT	(*1)
Releasing point of vertical magnetic field	BrpV	-4.0	-1.7	-0.1	mT	(*1)
Operating point of horizontal magnetic field	BopH	0.1	1.7	4.0	mT	(*2)
Operating point of horizontal magnetic field	BrpH	-4.0	-1.7	-0.1	mT	(*2)
Hysteresis	BhV, BhH	1.5	3.4	6.8	mT	(*1), (*2)

(*1) Horizontal magnetic flux density is zero.

(*2) Vertical magnetic flux density is zero.

Operational Characteristics

The signal OUTA switches 'Low' state (ON) when the magnetic field perpendicular to the marking side of the package exceeds B_{opV} . When the magnetic field is reduced below B_{rpV} , the OUTA goes 'High' state (OFF). Otherwise; that is, in case of the magnetic field strength is greater than B_{rpV} and smaller than B_{opV} ; OUTA keeps its status.

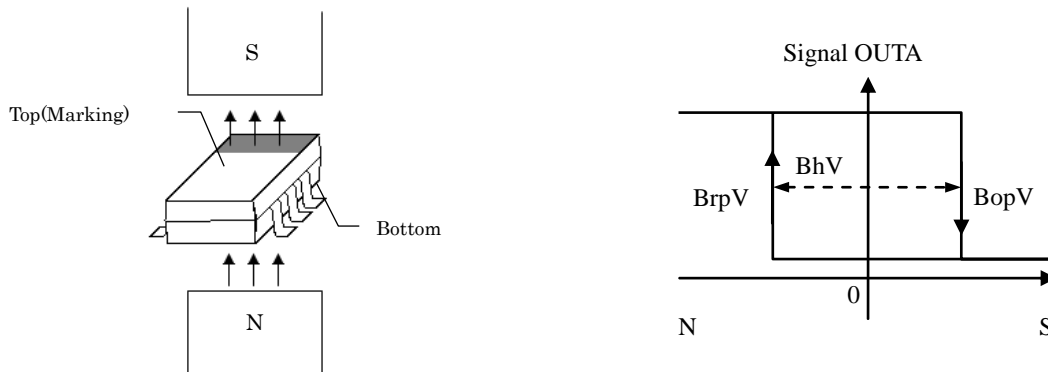

Figure 2. Switching behavior of the signal OUTA when vertical magnetic field is applied

The signal OUTB switches 'Low' state (ON) when the magnetic field parallel to the marking side of the package exceeds B_{opH} . When the magnetic field is reduced below B_{rpH} , the OUTB goes 'High' state (OFF). Otherwise; that is, in case of the magnetic field strength is greater than B_{rpH} and smaller than B_{opH} ; OUTB keeps its status.

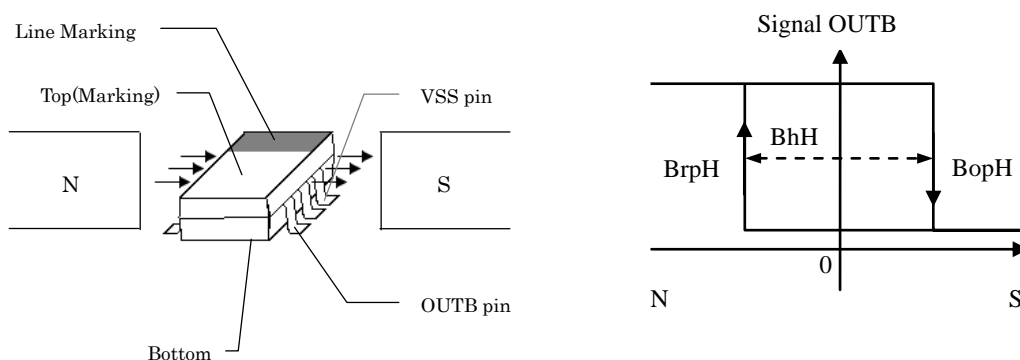

Figure 3. Switching behavior of the signal OUTB when horizontal magnetic field is applied

Functional Timing

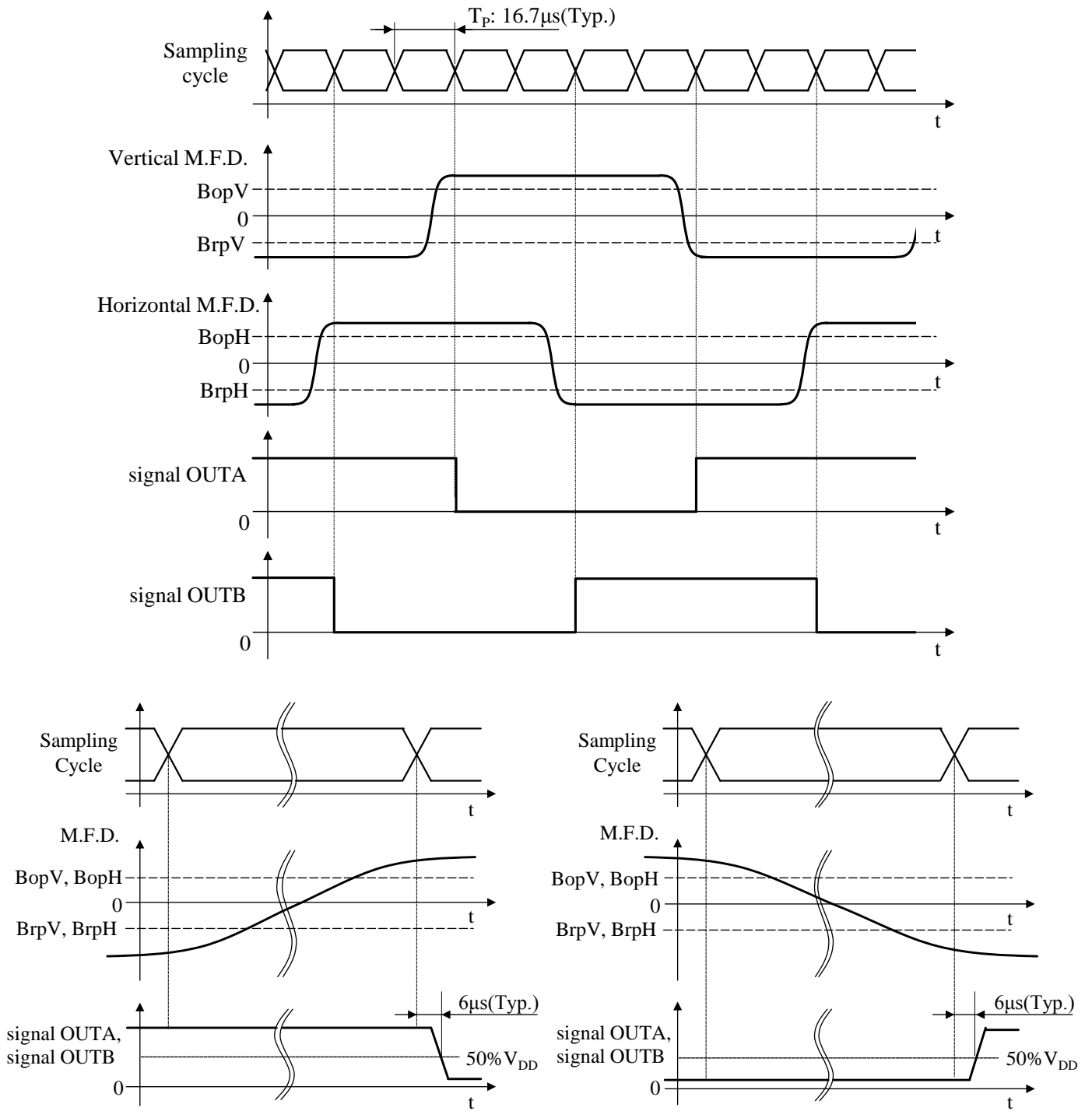

Figure 4. Timing diagram

*M.F.D. is Magnetic Flux Density.

Note) $V_{DD}=12.0V$, $R_L=10k\Omega$, $C_L=20pF$

Typical Characteristic Data (for reference)

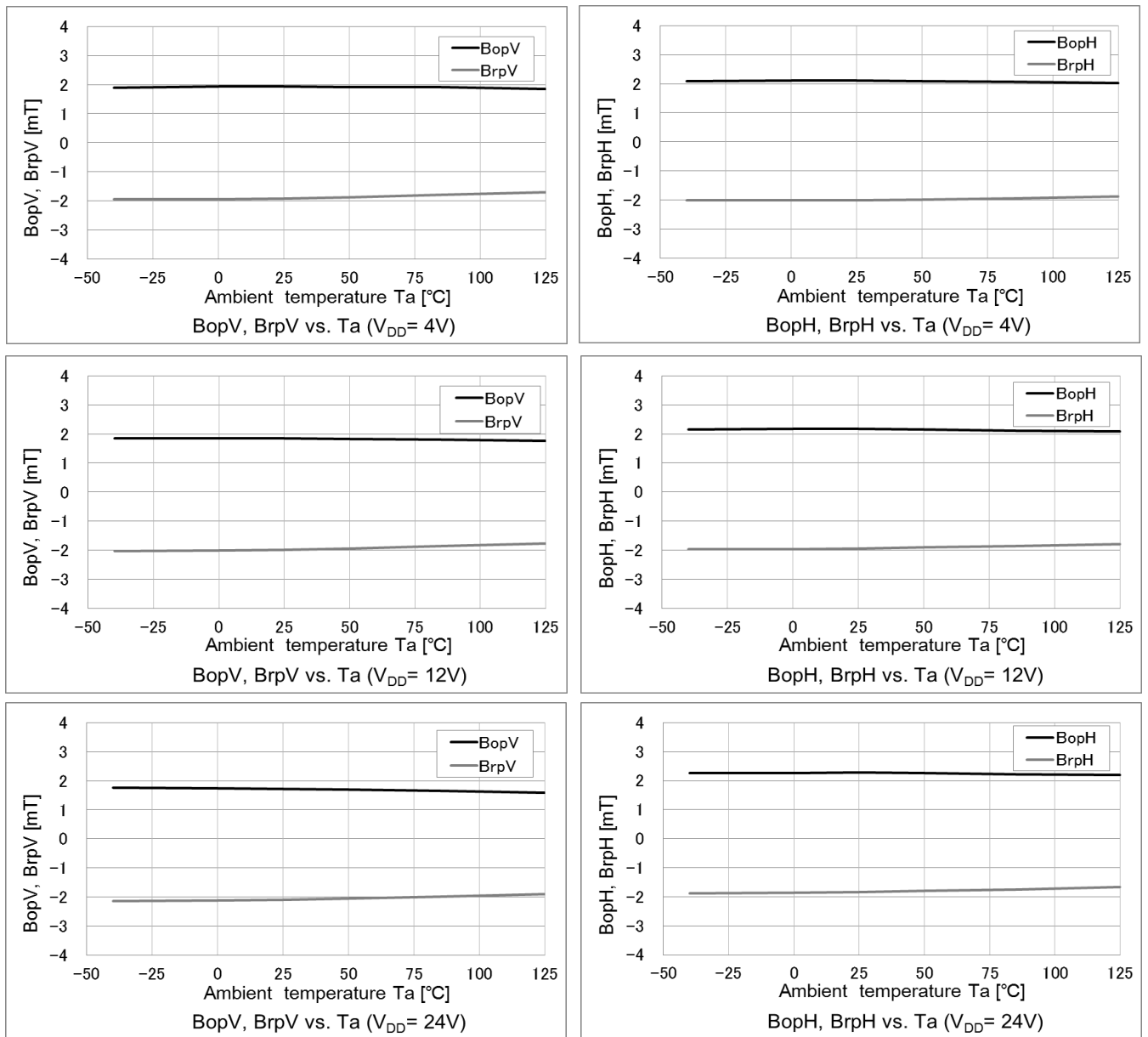

Figure 5. Temperature dependence of sensitivity

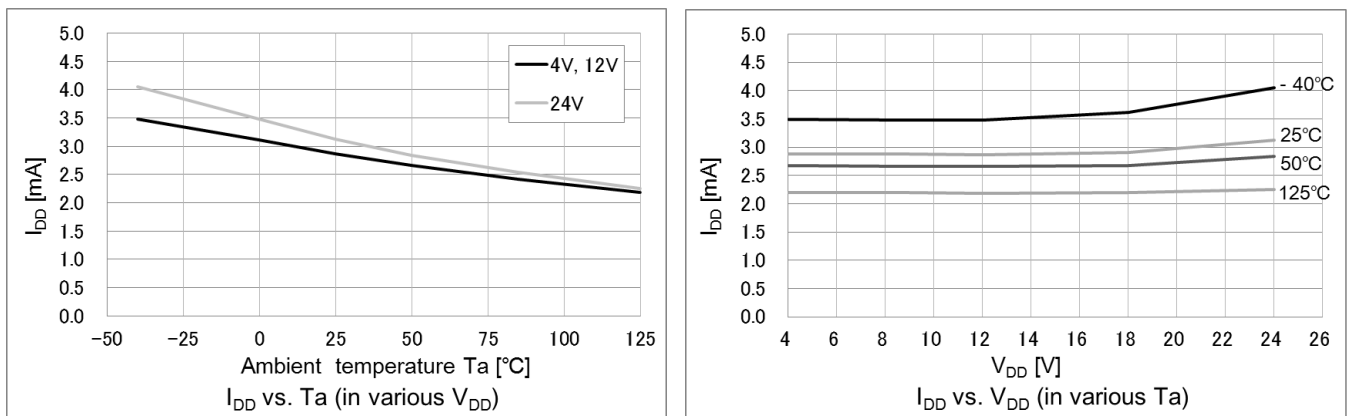

Figure 6. Temperature dependence of current consumption

Package

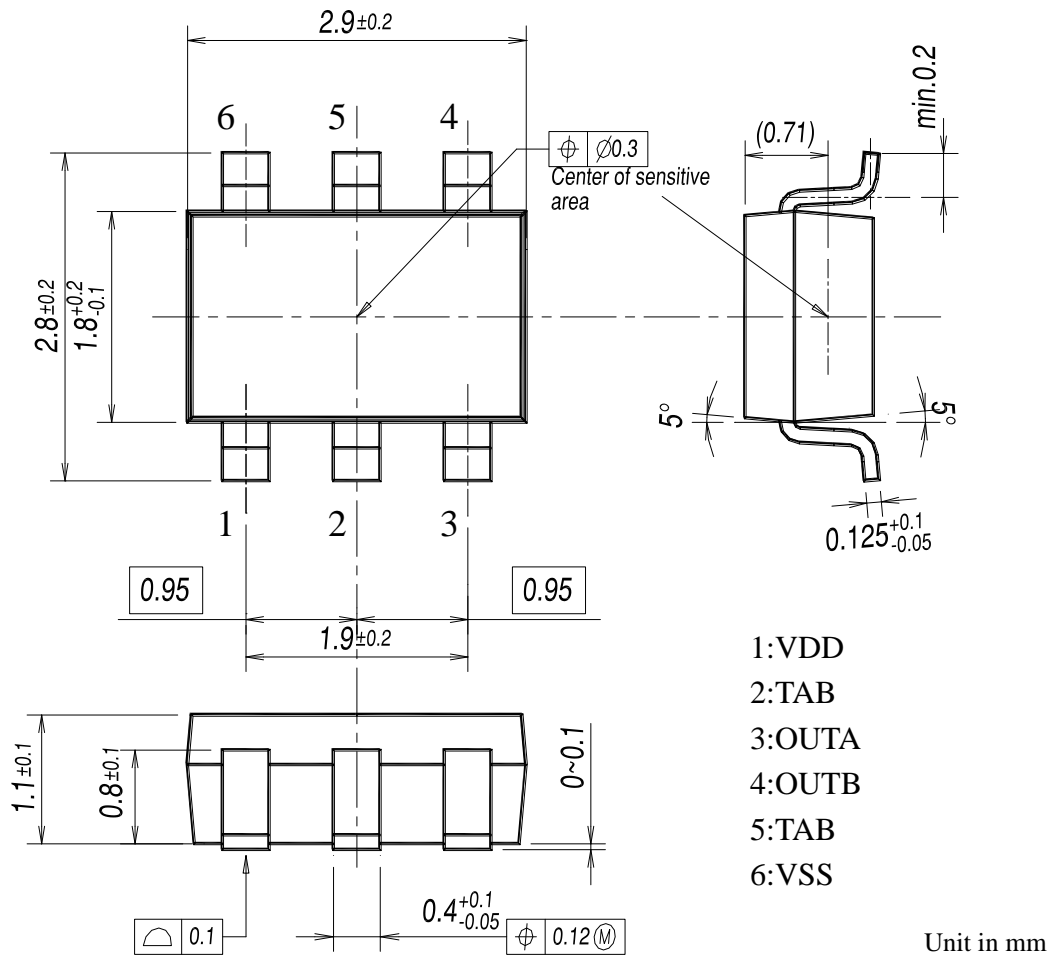

Figure 7. Package dimensions

Note 1) The center of the sensitive area is located within the $\phi 0.3$ mm circle.

Note 2) Coplanarity: The differences between standoff of terminals are max. 0.1mm.

Note 3) The sensor part is located 0.71mm(Typ.) from marking surface.

Material of terminals: Cu alloy

Material of plating for terminals: Sn 100%

Thickness of plating for terminals: 10 μ m (Typ.)

Marking

Line Marking

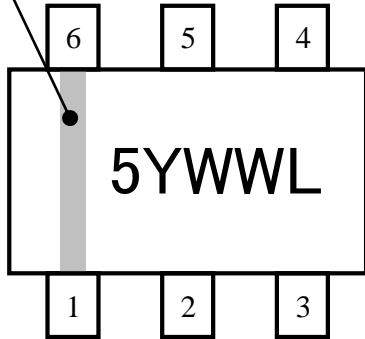

Marking is performed by laser

Product name : 5 (AK8777B)

Date code : YWWL

Y : Manufactured year

WW : Manufactured week

L : Lot

Figure 8. Marking

Recommended External Circuit

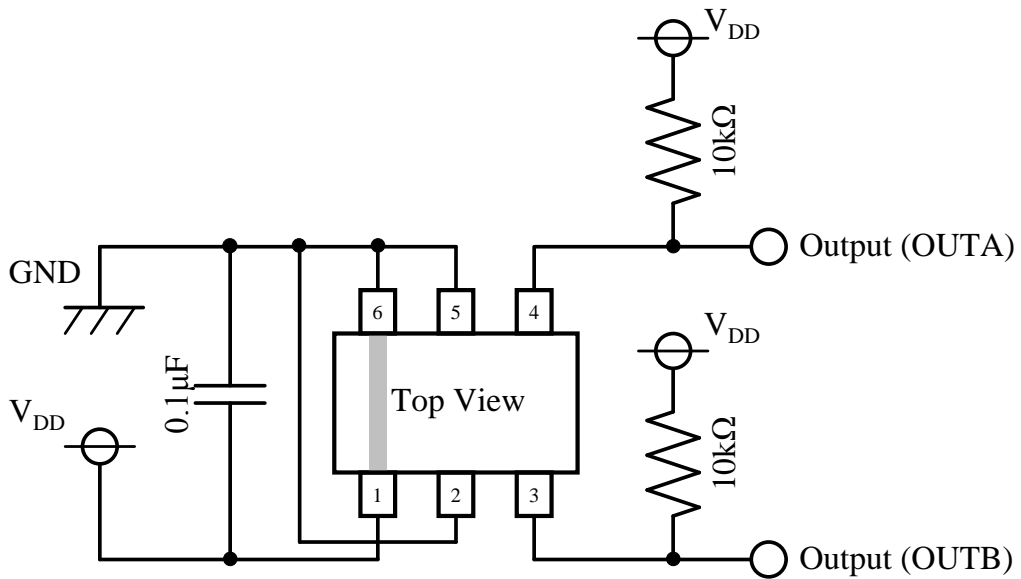

Figure 9. Recommended external circuit

IMPORTANT NOTICE

- These products and their specifications are subject to change without notice.
When you consider any use or application of these products, please make inquiries the sales office of Asahi Kasei Microdevices Corporation (AKM) or authorized distributors as to current status of the products.
- Descriptions of external circuits, application circuits, software and other related information contained in this document are provided only to illustrate the operation and application examples of the semiconductor products. You are fully responsible for the incorporation of these external circuits, application circuits, software and other related information in the design of your equipments. AKM assumes no responsibility for any losses incurred by you or third parties arising from the use of these information herein. AKM assumes no liability for infringement of any patent, intellectual property, or other rights in the application or use of such information contained herein.
- Any export of these products, or devices or systems containing them, may require an export license or other official approval under the law and regulations of the country of export pertaining to customs and tariffs, currency exchange, or strategic materials.
- AKM products are neither intended nor authorized for use as critical components_{Note1)} in any safety, life support, or other hazard related device or system_{Note2)}, and AKM assumes no responsibility for such use, except for the use approved with the express written consent by Representative Director of AKM. As used here:
Note1) A critical component is one whose failure to function or perform may reasonably be expected to result, whether directly or indirectly, in the loss of the safety or effectiveness of the device or system containing it, and which must therefore meet very high standards of performance and reliability.
Note2) A hazard related device or system is one designed or intended for life support or maintenance of safety or for applications in medicine, aerospace, nuclear energy, or other fields, in which its failure to function or perform may reasonably be expected to result in loss of life or in significant injury or damage to person or property.
- It is the responsibility of the buyer or distributor of AKM products, who distributes, disposes of, or otherwise places the product with a third party, to notify such third party in advance of the above content and conditions, and the buyer or distributor agrees to assume any and all responsibility and liability for and hold AKM harmless from any and all claims arising from the use of said product in the absence of such notification.