

## FEATURES

Latch-up immune under all circumstances  
 Human body model (HBM) ESD rating: 8 kV  
 Low on resistance: 13.5  $\Omega$   
 $\pm 9$  V to  $\pm 22$  V dual-supply operation  
 9 V to 40 V single-supply operation  
 48 V supply maximum ratings  
 Fully specified at  $\pm 15$  V,  $\pm 20$  V, +12 V, and +36 V  
 $V_{DD}$  to  $V_{SS}$  analog signal range

## APPLICATIONS

High voltage signal routing  
 Automatic test equipment  
 Analog front-end circuits  
 Precision data acquisition  
 Industrial instrumentation  
 Amplifier gain select  
 Relay replacement

## GENERAL DESCRIPTION

The [ADG5421/ADG5423](#) are monolithic industrial, complementary metal oxide semiconductor (CMOS) analog switches containing two independent latch-up immune single-pole/single-throw (SPST) switches. Each switch conducts equally well in both directions when on, and has an input signal range that extends to the power supplies. In the off condition, signal levels up to the supplies are blocked. Both [ADG5421](#) switches are turned on with a Logic 1 input, whereas the [ADG5423](#) has one switch turned on and one switch turned off for a Logic 1 input. The [ADG5423](#) exhibits break-before-make action for use in multiplexer applications.

The ultralow on resistance and on-resistance flatness of these switches make them ideal solutions for data acquisition and gain switching applications where low distortion is critical. The latch-up immune construction and high ESD rating make these switches more robust in harsh environments.

## FUNCTIONAL BLOCK DIAGRAMS

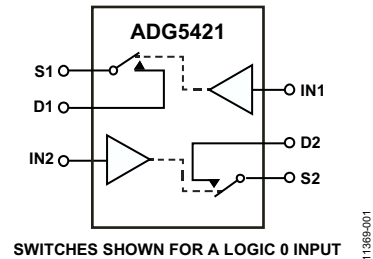
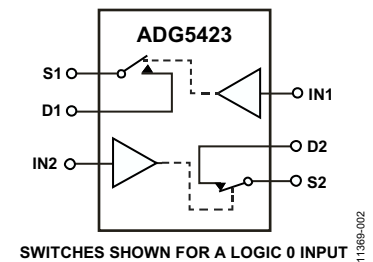
 Figure 1. [ADG5421](#)

 Figure 2. [ADG5423](#)

## PRODUCT HIGHLIGHTS

1. Trench isolation guards against latch-up. A dielectric trench separates the P channel and N channel transistors, thereby preventing latch-up even under severe overvoltage conditions.
2. Low  $R_{ON}$  of 13.5  $\Omega$ .
3. Dual-supply operation. For applications where the analog signal is bipolar, the [ADG5421/ADG5423](#) can operate from dual supplies up to  $\pm 22$  V.
4. Single-supply operation. For applications where the analog signal is unipolar, the [ADG5421/ADG5423](#) can operate from a single-rail power supply up to 40 V.
5. 3 V logic compatible digital inputs:  $V_{INH} = 2.0$  V,  $V_{INL} = 0.8$  V.
6. No  $V_I$  logic power supply required.
7. Available in 10-lead MSOP package.

Rev. 0

[Document Feedback](#)

Information furnished by Analog Devices is believed to be accurate and reliable. However, no responsibility is assumed by Analog Devices for its use, nor for any infringements of patents or other rights of third parties that may result from its use. Specifications subject to change without notice. No license is granted by implication or otherwise under any patent or patent rights of Analog Devices. Trademarks and registered trademarks are the property of their respective owners.

**TABLE OF CONTENTS**

Features .....	1	Continuous Current per Channel, Sx or Dx.....	7
Applications.....	1	Absolute Maximum Ratings .....	8
Functional Block Diagrams.....	1	ESD Caution.....	8
General Description .....	1	Pin Configurations and Function Descriptions.....	9
Product Highlights .....	1	Typical Performance Characteristics .....	10
Revision History .....	2	Test Circuits.....	13
Specifications.....	3	Terminology .....	15
±15 V Dual Supply .....	3	Applications Information .....	16
±20 V Dual Supply .....	4	Trench Isolation.....	16
12 V Single Supply.....	5	Outline Dimensions .....	17
36 V Single Supply.....	6	Ordering Guide .....	17

**REVISION HISTORY**

**9/13—Revision 0: Initial Version**

## SPECIFICATIONS

## ±15 V DUAL SUPPLY

$V_{DD} = +15\text{ V} \pm 10\%$ ,  $V_{SS} = -15\text{ V} \pm 10\%$ , GND = 0 V, unless otherwise noted.

Table 1.

Parameter	25°C	−40°C to +85°C	−40°C to +125°C	Unit	Test Conditions/Comments
<b>ANALOG SWITCH</b>					
Analog Signal Range			$V_{DD}$ to $V_{SS}$	V	
On Resistance, $R_{ON}$	13.5 15	19	23	$\Omega$ typ $\Omega$ max	$V_S = \pm 10\text{ V}$ , $I_S = -10\text{ mA}$ ; see Figure 24 $V_{DD} = +13.5\text{ V}$ , $V_{SS} = -13.5\text{ V}$
On-Resistance Match Between Channels, $\Delta R_{ON}$	0.1			$\Omega$ typ	$V_S = \pm 10\text{ V}$ , $I_S = -10\text{ mA}$
On-Resistance Flatness, $R_{FLAT(ON)}$	0.8 1.8 2.2	1.3	1.4 3.1	$\Omega$ max $\Omega$ typ $\Omega$ max	$V_S = \pm 10\text{ V}$ , $I_S = -10\text{ mA}$
<b>LEAKAGE CURRENTS</b>					
Source Off Leakage, $I_S$ (Off)	$\pm 0.05$ $\pm 0.25$	$\pm 1$	$\pm 10$	nA typ nA max	$V_{DD} = +16.5\text{ V}$ , $V_{SS} = -16.5\text{ V}$ $V_S = \pm 10\text{ V}$ , $V_D = \mp 10\text{ V}$ ; see Figure 23
Drain Off Leakage, $I_D$ (Off)	$\pm 0.05$ $\pm 0.25$	$\pm 1$	$\pm 10$	nA typ nA max	$V_S = \pm 10\text{ V}$ , $V_D = \mp 10\text{ V}$ ; see Figure 23
Channel On Leakage, $I_D$ (On), $I_S$ (On)	$\pm 0.1$ $\pm 0.4$	$\pm 4$	$\pm 20$	nA typ nA max	$V_S = V_D = \pm 10\text{ V}$ ; see Figure 22
<b>DIGITAL INPUTS</b>					
Input High Voltage, $V_{INH}$			2.0	V min	
Input Low Voltage, $V_{INL}$			0.8	V max	
Input Current, $I_{INL}$ or $I_{INH}$	0.002		$\pm 0.1$	$\mu\text{A}$ typ $\mu\text{A}$ max	$V_{IN} = V_{GND}$ or $V_{DD}$
Digital Input Capacitance, $C_{IN}$	6			pF typ	
<b>DYNAMIC CHARACTERISTICS<sup>1</sup></b>					
$t_{ON}$	185 220	273	313	ns typ ns max	$R_L = 300\ \Omega$ , $C_L = 35\text{ pF}$ $V_S = 10\text{ V}$ ; see Figure 29
$t_{OFF}$	163 196	219	242	ns typ ns max	$R_L = 300\ \Omega$ , $C_L = 35\text{ pF}$ $V_S = 10\text{ V}$ ; see Figure 29
Break-Before-Make Time Delay, $t_D$ (ADG5423 Only)	73		21	ns typ	$R_L = 300\ \Omega$ , $C_L = 35\text{ pF}$
Charge Injection, $Q_{INJ}$	95			ns min pC typ	$V_{S1} = V_{S2} = 10\text{ V}$ ; see Figure 31 $V_S = 0\text{ V}$ , $R_S = 0\ \Omega$ , $C_L = 1\text{ nF}$ ; see Figure 30
Off Isolation	−55			dB typ	$R_L = 50\ \Omega$ , $C_L = 5\text{ pF}$ , $f = 1\text{ MHz}$ ; see Figure 25
Channel-to-Channel Crosstalk	−85			dB typ	$R_L = 50\ \Omega$ , $C_L = 5\text{ pF}$ , $f = 1\text{ MHz}$ ; see Figure 28
Total Harmonic Distortion + Noise	0.01			% typ	$R_L = 1\text{ k}\Omega$ , 15 V p-p, $f = 20\text{ Hz}$ to 20 kHz; see Figure 26
−3 dB Bandwidth	250			MHz typ	$R_L = 50\ \Omega$ , $C_L = 5\text{ pF}$ ; see Figure 27
Insertion Loss	−1			dB typ	$R_L = 50\ \Omega$ , $C_L = 5\text{ pF}$ , $f = 1\text{ MHz}$ ; see Figure 27
$C_S$ (Off)	12			pF typ	$V_S = 0\text{ V}$ , $f = 1\text{ MHz}$
$C_D$ (Off)	13			pF typ	$V_S = 0\text{ V}$ , $f = 1\text{ MHz}$
$C_D$ (On), $C_S$ (On)	44			pF typ	$V_S = 0\text{ V}$ , $f = 1\text{ MHz}$
<b>POWER REQUIREMENTS</b>					
$I_{DD}$	45 55		70	$\mu\text{A}$ typ $\mu\text{A}$ max	$V_{DD} = +16.5\text{ V}$ , $V_{SS} = -16.5\text{ V}$ Digital inputs = 0 V or $V_{DD}$
$I_{SS}$	0.001		1	$\mu\text{A}$ typ $\mu\text{A}$ max	Digital inputs = 0 V or $V_{DD}$
$V_{DD}/V_{SS}$			$\pm 9/\pm 22$	V min/V max	GND = 0 V

<sup>1</sup> Guaranteed by design; not subject to production test.

**±20 V DUAL SUPPLY**

$V_{DD} = +20\text{ V} \pm 10\%$ ,  $V_{SS} = -20\text{ V} \pm 10\%$ ,  $GND = 0\text{ V}$ , unless otherwise noted.

**Table 2.**

Parameter	25°C	-40°C to +85°C	-40°C to +125°C	Unit	Test Conditions/Comments
<b>ANALOG SWITCH</b>					
Analog Signal Range			$V_{DD}$ to $V_{SS}$	V	
On Resistance, $R_{ON}$	12.5 14	18	22	$\Omega$ typ $\Omega$ max	$V_S = \pm 15\text{ V}$ , $I_S = -10\text{ mA}$ ; see Figure 24 $V_{DD} = +18\text{ V}$ , $V_{SS} = -18\text{ V}$
On-Resistance Match Between Channels, $\Delta R_{ON}$	0.1			$\Omega$ typ	$V_S = \pm 15\text{ V}$ , $I_S = -10\text{ mA}$
On-Resistance Flatness, $R_{FLAT(ON)}$	0.8	1.3	1.4	$\Omega$ max	
	2.3 2.7	3.3	3.7	$\Omega$ typ $\Omega$ max	$V_S = \pm 15\text{ V}$ , $I_S = -10\text{ mA}$
<b>LEAKAGE CURRENTS</b>					
Source Off Leakage, $I_S$ (Off)	$\pm 0.05$			nA typ	$V_{DD} = +22\text{ V}$ , $V_{SS} = -22\text{ V}$ $V_S = \pm 15\text{ V}$ , $V_D = \mp 15\text{ V}$ ; see Figure 23
Drain Off Leakage, $I_D$ (Off)	$\pm 0.25$	$\pm 1$	$\pm 10$	nA max	
	$\pm 0.05$			nA typ	$V_S = \pm 15\text{ V}$ , $V_D = \mp 15\text{ V}$ ; see Figure 23
Channel On Leakage, $I_D$ (On), $I_S$ (On)	$\pm 0.25$	$\pm 1$	$\pm 10$	nA max	
	$\pm 0.1$ $\pm 0.4$	$\pm 4$	$\pm 20$	nA typ nA max	$V_S = V_D = \pm 15\text{ V}$ ; see Figure 22
<b>DIGITAL INPUTS</b>					
Input High Voltage, $V_{INH}$			2.0	V min	
Input Low Voltage, $V_{INL}$			0.8	V max	
Input Current, $I_{INL}$ or $I_{INH}$	0.002		$\pm 0.1$	$\mu\text{A}$ typ $\mu\text{A}$ max	$V_{IN} = V_{GND}$ or $V_{DD}$
Digital Input Capacitance, $C_{IN}$	6			pF typ	
<b>DYNAMIC CHARACTERISTICS<sup>1</sup></b>					
$t_{ON}$	168			ns typ	$R_L = 300\ \Omega$ , $C_L = 35\text{ pF}$ , $V_S = 10\text{ V}$ ; see Figure 29
$t_{OFF}$	199	243	276	ns max	$V_S = 10\text{ V}$ ; see Figure 29
	156			ns typ	$R_L = 300\ \Omega$ , $C_L = 35\text{ pF}$
Break-Before-Make Time Delay, $t_D$ (ADG5423 Only)	184	204	218	ns max	$V_S = 10\text{ V}$ ; see Figure 29
	65			ns typ	$R_L = 300\ \Omega$ , $C_L = 35\text{ pF}$
Charge Injection, $Q_{INJ}$			38	ns min	$V_{S1} = V_{S2} = 10\text{ V}$ ; see Figure 31
	120			pC typ	$V_S = 0\text{ V}$ , $R_S = 0\ \Omega$ , $C_L = 1\text{ nF}$ ; see Figure 30
Off Isolation	-55			dB typ	$R_L = 50\ \Omega$ , $C_L = 5\text{ pF}$ , $f = 1\text{ MHz}$ ; see Figure 25
Channel-to-Channel Crosstalk	-85			dB typ	$R_L = 50\ \Omega$ , $C_L = 5\text{ pF}$ , $f = 1\text{ MHz}$ ; see Figure 28
Total Harmonic Distortion + Noise	0.01			% typ	$R_L = 1\text{ k}\Omega$ , 20 V p-p, $f = 20\text{ Hz}$ to 20 kHz; see Figure 26
-3 dB Bandwidth	250			MHz typ	$R_L = 50\ \Omega$ , $C_L = 5\text{ pF}$ ; see Figure 27
Insertion Loss	-0.8			dB typ	$R_L = 50\ \Omega$ , $C_L = 5\text{ pF}$ , $f = 1\text{ MHz}$ ; see Figure 27
$C_S$ (Off)	11			pF typ	$V_S = 0\text{ V}$ , $f = 1\text{ MHz}$
$C_D$ (Off)	12			pF typ	$V_S = 0\text{ V}$ , $f = 1\text{ MHz}$
$C_D$ (On), $C_S$ (On)	44			pF typ	$V_S = 0\text{ V}$ , $f = 1\text{ MHz}$
<b>POWER REQUIREMENTS</b>					
$I_{DD}$	50			$\mu\text{A}$ typ	$V_{DD} = +22\text{ V}$ , $V_{SS} = -22\text{ V}$ Digital inputs = 0 V or $V_{DD}$
	70		110	$\mu\text{A}$ max	
$I_{SS}$	0.001			$\mu\text{A}$ typ	Digital inputs = 0 V or $V_{DD}$
			1	$\mu\text{A}$ max	
$V_{DD}/V_{SS}$			$\pm 9/\pm 22$	V min/V max	$GND = 0\text{ V}$

<sup>1</sup> Guaranteed by design; not subject to production test.

**12 V SINGLE SUPPLY**

$V_{DD} = 12\text{ V} \pm 10\%$ ,  $V_{SS} = 0\text{ V}$ ,  $GND = 0\text{ V}$ , unless otherwise noted.

**Table 3.**

Parameter	25°C	-40°C to +85°C	-40°C to +125°C	Unit	Test Conditions/Comments
<b>ANALOG SWITCH</b>					
Analog Signal Range			0 V to $V_{DD}$	V	
On Resistance, $R_{ON}$	26			$\Omega$ typ	$V_S = 0\text{ V to }10\text{ V}$ , $I_S = -10\text{ mA}$ ; see Figure 24
On-Resistance Match Between Channels, $\Delta R_{ON}$	30	38	44	$\Omega$ max	$V_{DD} = 10.8\text{ V}$ , $V_{SS} = 0\text{ V}$
	0.1			$\Omega$ typ	$V_S = 0\text{ V to }10\text{ V}$ , $I_S = -10\text{ mA}$
On-Resistance Flatness, $R_{FLAT(ON)}$	1	1.5	1.6	$\Omega$ max	
	5.5			$\Omega$ typ	$V_S = 0\text{ V to }10\text{ V}$ , $I_S = -10\text{ mA}$
	6.8	8.3	12.3	$\Omega$ max	
<b>LEAKAGE CURRENTS</b>					
Source Off Leakage, $I_S$ (Off)	$\pm 0.05$			nA typ	$V_{DD} = +13.2\text{ V}$ , $V_{SS} = 0\text{ V}$ $V_S = 1\text{ V to }10\text{ V}$ , $V_D = 10\text{ V to }1\text{ V}$ ; see Figure 23
Drain Off Leakage, $I_D$ (Off)	$\pm 0.25$ $\pm 0.05$	$\pm 1$	$\pm 10$	nA max nA typ	$V_S = 1\text{ V to }10\text{ V}$ , $V_D = 10\text{ V to }1\text{ V}$ ; see Figure 23
Channel On Leakage, $I_D$ (On), $I_S$ (On)	$\pm 0.25$ $\pm 0.1$ $\pm 0.4$	$\pm 1$ $\pm 4$	$\pm 10$ $\pm 20$	nA max nA typ nA max	$V_S = V_D = 1\text{ V to }10\text{ V}$ ; see Figure 22
<b>DIGITAL INPUTS</b>					
Input High Voltage, $V_{INH}$			2.0	V min	
Input Low Voltage, $V_{INL}$			0.8	V max	
Input Current, $I_{INL}$ or $I_{INH}$	0.002			$\mu\text{A}$ typ $\mu\text{A}$ max	$V_{IN} = V_{GND}$ or $V_{DD}$
Digital Input Capacitance, $C_{IN}$	6		$\pm 0.1$	pF typ	
<b>DYNAMIC CHARACTERISTICS<sup>1</sup></b>					
$t_{ON}$	295			ns typ	$R_L = 300\ \Omega$ , $C_L = 35\text{ pF}$
	370	470	540	ns max	$V_S = 8\text{ V}$ ; see Figure 29
$t_{OFF}$	192			ns typ	$R_L = 300\ \Omega$ , $C_L = 35\text{ pF}$
	235	273	295	ns max	$V_S = 8\text{ V}$ ; see Figure 29
Break-Before-Make Time Delay, $t_D$ (ADG5423 Only)	142			ns typ	$R_L = 300\ \Omega$ , $C_L = 35\text{ pF}$
			78	ns min	$V_{S1} = V_{S2} = 8\text{ V}$ ; see Figure 31
Charge Injection, $Q_{INJ}$	55			pC typ	$V_S = 6\text{ V}$ , $R_S = 0\ \Omega$ , $C_L = 1\text{ nF}$ ; see Figure 30
Off Isolation	-55			dB typ	$R_L = 50\ \Omega$ , $C_L = 5\text{ pF}$ , $f = 1\text{ MHz}$ ; see Figure 25
Channel-to-Channel Crosstalk	-85			dB typ	$R_L = 50\ \Omega$ , $C_L = 5\text{ pF}$ , $f = 1\text{ MHz}$ ; see Figure 28
Total Harmonic Distortion + Noise	0.03			% typ	$R_L = 1\text{ k}\Omega$ , $6\text{ V p-p}$ , $f = 20\text{ Hz to }20\text{ kHz}$ ; see Figure 26
-3 dB Bandwidth	290			MHz typ	$R_L = 50\ \Omega$ , $C_L = 5\text{ pF}$ ; see Figure 27
Insertion Loss	-1.7			dB typ	$R_L = 50\ \Omega$ , $C_L = 5\text{ pF}$ , $f = 1\text{ MHz}$ ; see Figure 27
$C_S$ (Off)	14			pF typ	$V_S = 6\text{ V}$ , $f = 1\text{ MHz}$
$C_D$ (Off)	15			pF typ	$V_S = 6\text{ V}$ , $f = 1\text{ MHz}$
$C_D$ (On), $C_S$ (On)	38			pF typ	$V_S = 6\text{ V}$ , $f = 1\text{ MHz}$
<b>POWER REQUIREMENTS</b>					
$I_{DD}$	40			$\mu\text{A}$ typ	$V_{DD} = 13.2\text{ V}$ Digital inputs = 0 V or $V_{DD}$
	50		65	$\mu\text{A}$ max	
$V_{DD}$			9/40	V min/V max	$GND = 0\text{ V}$ , $V_{SS} = 0\text{ V}$

<sup>1</sup> Guaranteed by design; not subject to production test.

**36 V SINGLE SUPPLY**

$V_{DD} = 36\text{ V} \pm 10\%$ ,  $V_{SS} = 0\text{ V}$ ,  $GND = 0\text{ V}$ , unless otherwise noted.

**Table 4.**

Parameter	25°C	−40°C to +85°C	−40°C to +125°C	Unit	Test Conditions/Comments
<b>ANALOG SWITCH</b>					
Analog Signal Range			0 V to $V_{DD}$	V	
On Resistance, $R_{ON}$	14.5			$\Omega$ typ	$V_S = 0\text{ V to }30\text{ V}$ , $I_S = -10\text{ mA}$ ; see Figure 24
	16	20	24	$\Omega$ max	$V_{DD} = 32.4\text{ V}$ , $V_{SS} = 0\text{ V}$
On-Resistance Match Between Channels, $\Delta R_{ON}$	0.1			$\Omega$ typ	$V_S = 0\text{ V to }30\text{ V}$ , $I_S = -10\text{ mA}$
On-Resistance Flatness, $R_{FLAT(ON)}$	0.8	1.3	1.4	$\Omega$ max	
	3.5			$\Omega$ typ	$V_S = 0\text{ V to }30\text{ V}$ , $I_S = -10\text{ mA}$
	4.3	5.5	6.5	$\Omega$ max	
<b>LEAKAGE CURRENTS</b>					
Source Off Leakage, $I_S$ (Off)	$\pm 0.05$			nA typ	$V_{DD} = 39.6\text{ V}$ , $V_{SS} = 0\text{ V}$ $V_S = 1\text{ V to }30\text{ V}$ , $V_D = 30\text{ V to }1\text{ V}$ ; see Figure 23
Drain Off Leakage, $I_D$ (Off)	$\pm 0.25$ $\pm 0.05$	$\pm 1$	$\pm 10$	nA max nA typ	$V_S = 1\text{ V to }30\text{ V}$ , $V_D = 30\text{ V to }1\text{ V}$ ; see Figure 23
Channel On Leakage, $I_D$ (On), $I_S$ (On)	$\pm 0.25$ $\pm 0.1$ $\pm 0.4$	$\pm 1$ $\pm 4$	$\pm 10$ $\pm 20$	nA max nA typ nA max	$V_S = V_D = 1\text{ V to }30\text{ V}$ ; see Figure 22
<b>DIGITAL INPUTS</b>					
Input High Voltage, $V_{INH}$			2.0	V min	
Input Low Voltage, $V_{INL}$			0.8	V max	
Input Current, $I_{INL}$ or $I_{INH}$	0.002		$\pm 0.1$	$\mu\text{A}$ typ $\mu\text{A}$ max	$V_{IN} = V_{GND}$ or $V_{DD}$
Digital Input Capacitance, $C_{IN}$	6			pF typ	
<b>DYNAMIC CHARACTERISTICS<sup>1</sup></b>					
$t_{ON}$	181			ns typ	$R_L = 300\ \Omega$ , $C_L = 35\text{ pF}$
	210	245	280	ns max	$V_S = 18\text{ V}$ ; see Figure 29
$t_{OFF}$	170			ns typ	$R_L = 300\ \Omega$ , $C_L = 35\text{ pF}$
	192	205	220	ns max	$V_S = 18\text{ V}$ ; see Figure 29
Break-Before-Make Time Delay, $t_D$ (ADG5423 Only)	66			ns typ	$R_L = 300\ \Omega$ , $C_L = 35\text{ pF}$
			37	ns min	$V_{S1} = V_{S2} = 18\text{ V}$ ; see Figure 31
Charge Injection, $Q_{INI}$	110			pC typ	$V_S = 18\text{ V}$ , $R_S = 0\ \Omega$ , $C_L = 1\text{ nF}$ ; see Figure 30
Off Isolation	−55			dB typ	$R_L = 50\ \Omega$ , $C_L = 5\text{ pF}$ , $f = 1\text{ MHz}$ ; see Figure 25
Channel-to-Channel Crosstalk	−85			dB typ	$R_L = 50\ \Omega$ , $C_L = 5\text{ pF}$ , $f = 1\text{ MHz}$ ; see Figure 28
Total Harmonic Distortion + Noise	0.01			% typ	$R_L = 1\text{ k}\Omega$ , 18 V p-p, $f = 20\text{ Hz to }20\text{ kHz}$ ; see Figure 26
−3 dB Bandwidth	260			MHz typ	$R_L = 50\ \Omega$ , $C_L = 5\text{ pF}$ ; see Figure 27
Insertion Loss	−0.9			dB typ	$R_L = 50\ \Omega$ , $C_L = 5\text{ pF}$ , $f = 1\text{ MHz}$ ; see Figure 27
$C_S$ (Off)	13			pF typ	$V_S = 18\text{ V}$ , $f = 1\text{ MHz}$
$C_D$ (Off)	16			pF typ	$V_S = 18\text{ V}$ , $f = 1\text{ MHz}$
$C_D$ (On), $C_S$ (On)	38			pF typ	$V_S = 18\text{ V}$ , $f = 1\text{ MHz}$
<b>POWER REQUIREMENTS</b>					
$I_{DD}$	80			$\mu\text{A}$ typ	$V_{DD} = 39.6\text{ V}$ Digital inputs = 0 V or $V_{DD}$
	100		130	$\mu\text{A}$ max	
$V_{DD}$			9/40	V min/V max	$GND = 0\text{ V}$ , $V_{SS} = 0\text{ V}$

<sup>1</sup> Guaranteed by design; not subject to production test.

**CONTINUOUS CURRENT PER CHANNEL, Sx OR Dx**

Table 5.

Parameter	25°C	85°C	125°C	Unit	Test Conditions/Comments
CONTINUOUS CURRENT, Sx OR Dx					MSOP ( $\theta_{JA} = 133.1^{\circ}\text{C/W}$ )
$V_{DD} = +15\text{ V}, V_{SS} = -15\text{ V}$	84	58	39	mA maximum	
$V_{DD} = +20\text{ V}, V_{SS} = -20\text{ V}$	89	60	41	mA maximum	
$V_{DD} = 12\text{ V}, V_{SS} = 0\text{ V}$	67	47	32	mA maximum	
$V_{DD} = 36\text{ V}, V_{SS} = 0\text{ V}$	87	59	40	mA maximum	

## ABSOLUTE MAXIMUM RATINGS

$T_A = 25^\circ\text{C}$ , unless otherwise noted.

**Table 6.**

Parameter	Rating
$V_{DD}$ to $V_{SS}$	48 V
$V_{DD}$ to GND	-0.3 V to +48 V
$V_{SS}$ to GND	+0.3 V to -48 V
Analog Inputs <sup>1</sup>	$V_{SS} - 0.3\text{ V}$ to $V_{DD} + 0.3\text{ V}$ or 30 mA, whichever occurs first
Digital Inputs <sup>1</sup>	$V_{SS} - 0.3\text{ V}$ to $V_{DD} + 0.3\text{ V}$ or 30 mA, whichever occurs first
Peak Current, Sx or Dx Pins	300 mA (pulsed at 1 ms, 10% duty cycle maximum)
Continuous Current, Sx or Dx <sup>2</sup>	Data + 15%
Temperature Range	
Operating	-40°C to +125°C
Storage	-65°C to +150°C
Junction Temperature	150°C
Thermal Impedance, $\theta_{JA}$	
10-Lead MSOP (4-Layer Board)	133.1°C/W
Reflow Soldering Peak Temperature, Pb Free	As per JEDEC J-STD-020
Human Body Model (HBM) ESD	8 kV

<sup>1</sup> Overvoltages at the INx, Sx, and Dx pins are clamped by internal diodes.  
Limit current to the maximum ratings given.

<sup>2</sup> See Table 5.

Stresses above those listed under Absolute Maximum Ratings may cause permanent damage to the device. This is a stress rating only; functional operation of the device at these or any other conditions above those indicated in the operational section of this specification is not implied. Exposure to absolute maximum rating conditions for extended periods may affect device reliability.

Only one absolute maximum rating can be applied at any one time.

### ESD CAUTION



#### ESD (electrostatic discharge) sensitive device.

Charged devices and circuit boards can discharge without detection. Although this product features patented or proprietary protection circuitry, damage may occur on devices subjected to high energy ESD. Therefore, proper ESD precautions should be taken to avoid performance degradation or loss of functionality.



## PIN CONFIGURATION AND FUNCTION DESCRIPTIONS

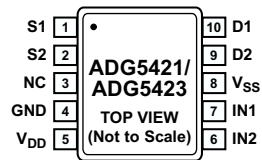

## NOTES

1. NC = NO CONNECT. NOT INTERNALLY CONNECTED.

11389-003

Figure 3. Pin Configuration

Table 7. Pin Function Descriptions

Pin No.	Mnemonic	Description
1	S1	Source Terminal 1. This pin can be an input or output.
2	S2	Source Terminal 2. This pin can be an input or output.
3	NC	No Connect. Not internally connected.
4	GND	Ground (0 V) Reference.
5	V <sub>DD</sub>	Most Positive Power Supply Potential.
6	IN2	Logic Control Input.
7	IN1	Logic Control Input.
8	V <sub>SS</sub>	Most Negative Power Supply Potential.
9	D2	Drain Terminal 2. This pin can be an input or output.
10	D1	Drain Terminal 1. This pin can be an input or output.

Table 8. ADG5421 Truth Table

INx	Switch Conditions
0	Off
1	On

Table 9. ADG5423 Truth Table

INx	Switch 1 Condition	Switch 2 Condition
0	Off	On
1	On	Off

TYPICAL PERFORMANCE CHARACTERISTICS

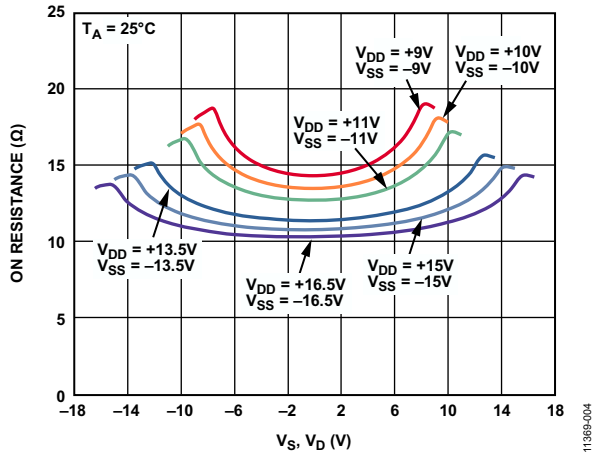

Figure 4. On Resistance as a Function of  $V_S, V_D$  (Dual Supply:  $\pm 10\text{ V}, \pm 15\text{ V}$ )

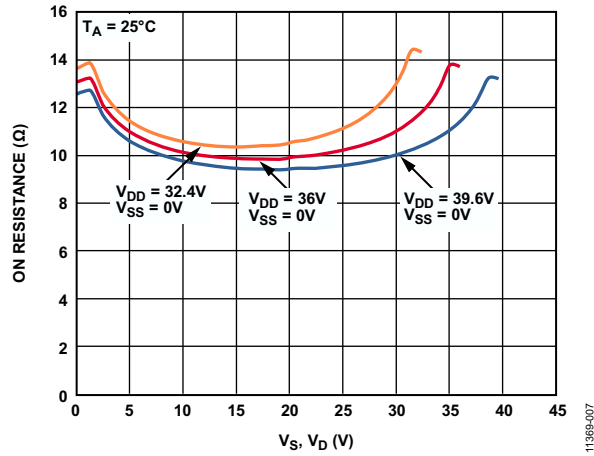

Figure 7. On Resistance as a Function of  $V_S, V_D$  (Single Supply:  $36\text{ V}$ )

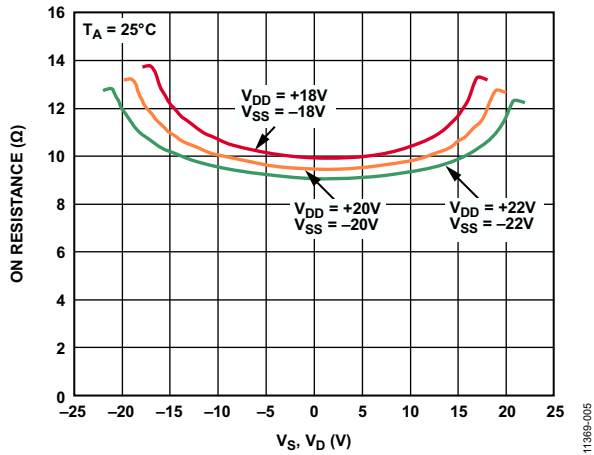

Figure 5. On Resistance as a Function of  $V_S, V_D$  (Dual Supply:  $\pm 20\text{ V}$ )

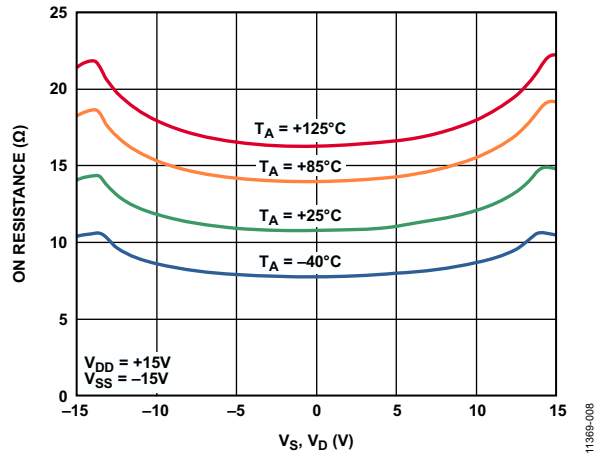

Figure 8. On Resistance as a Function of  $V_S (V_D)$  for Different Temperatures,  $\pm 15\text{ V}$  Dual Supply

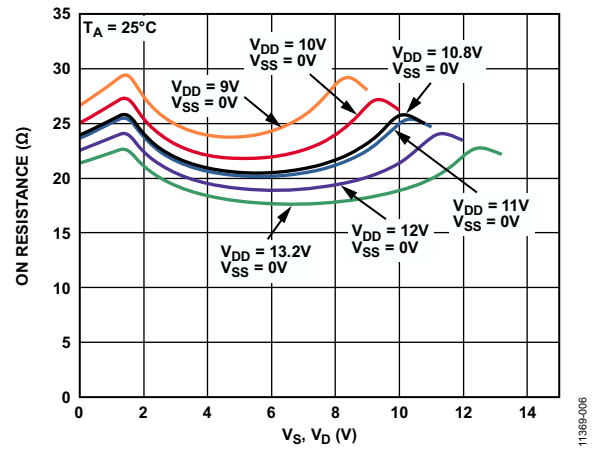

Figure 6. On Resistance as a Function of  $V_S, V_D$  (Single Supply:  $10\text{ V}, 12\text{ V}$ )

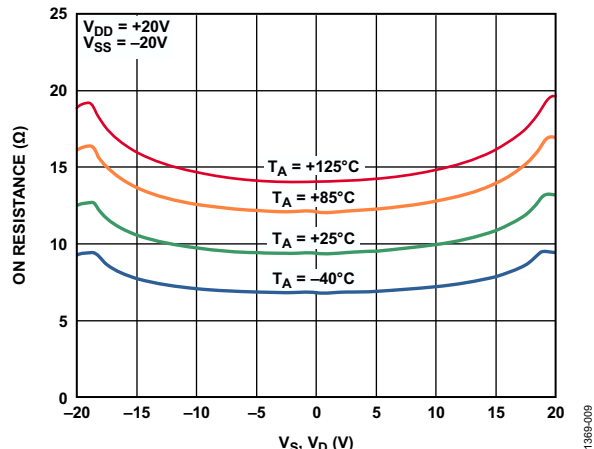

Figure 9. On Resistance as a Function of  $V_S (V_D)$  for Different Temperatures,  $\pm 20\text{ V}$  Dual Supply

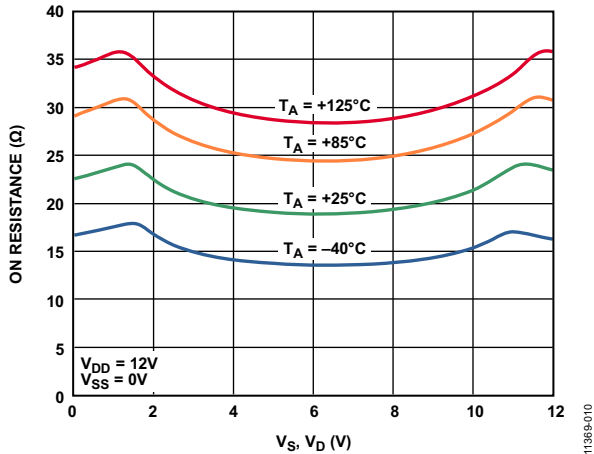

Figure 10. On Resistance as a Function of  $V_S$  ( $V_D$ ) for Different Temperatures, 12 V Single Supply

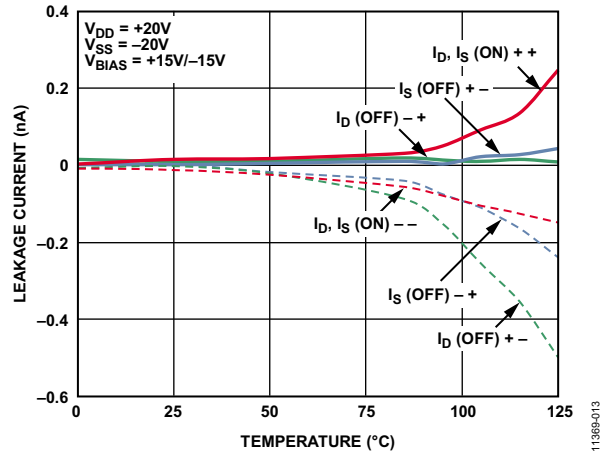

Figure 13. Leakage Currents as a Function of Temperature,  $\pm 20$  V Dual Supply

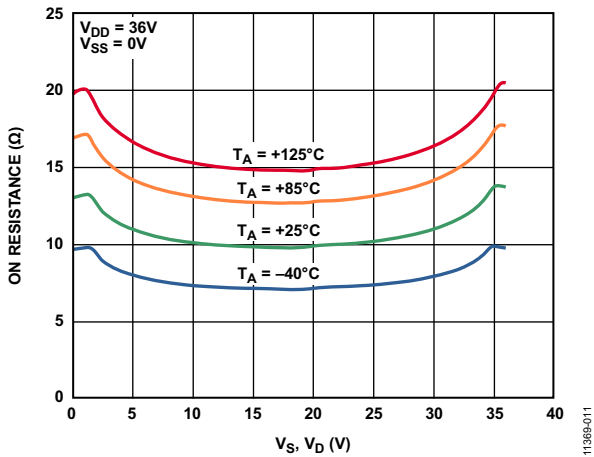

Figure 11. On Resistance as a Function of  $V_S$  ( $V_D$ ) for Different Temperatures, 36 V Single Supply

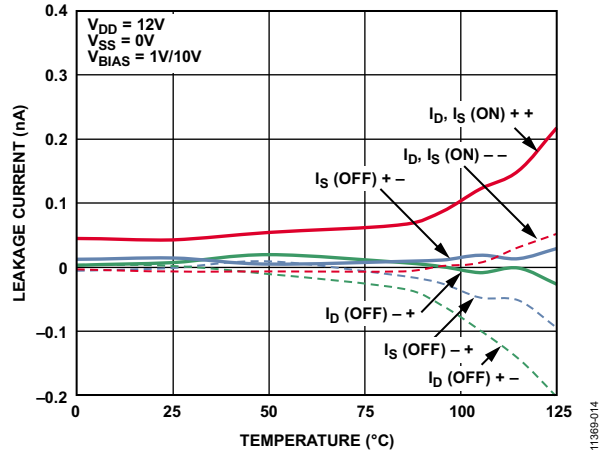

Figure 14. Leakage Currents as a Function of Temperature, 12 V Single Supply

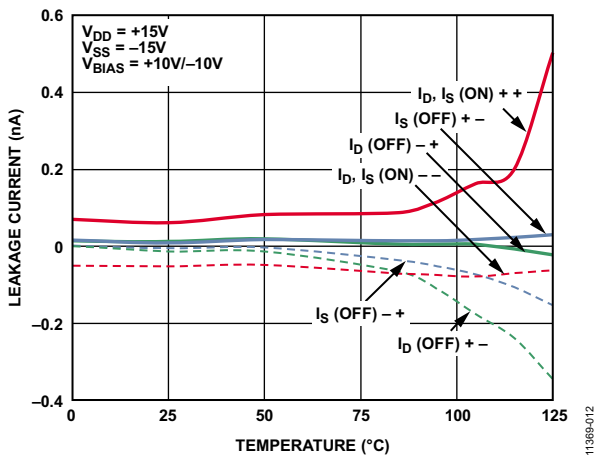

Figure 12. Leakage Currents as a Function of Temperature,  $\pm 15$  V Dual Supply

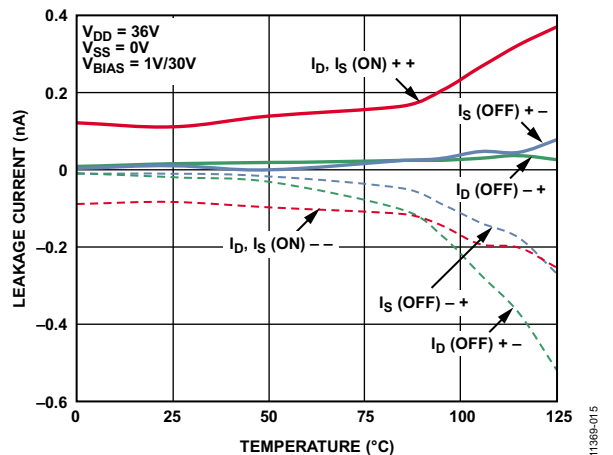

Figure 15. Leakage Currents as a Function of Temperature, 36 V Single Supply

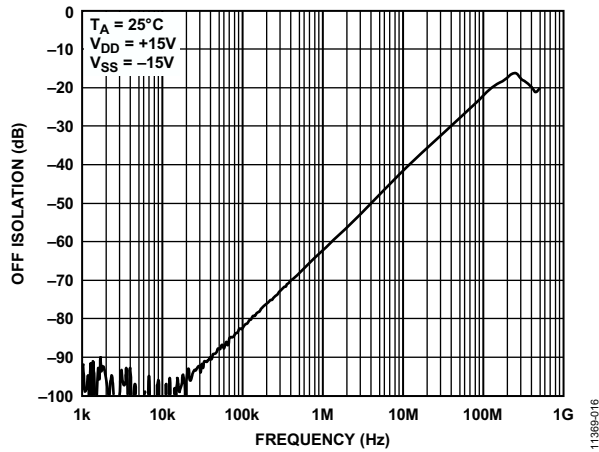

Figure 16. Off Isolation vs. Frequency

11369-016

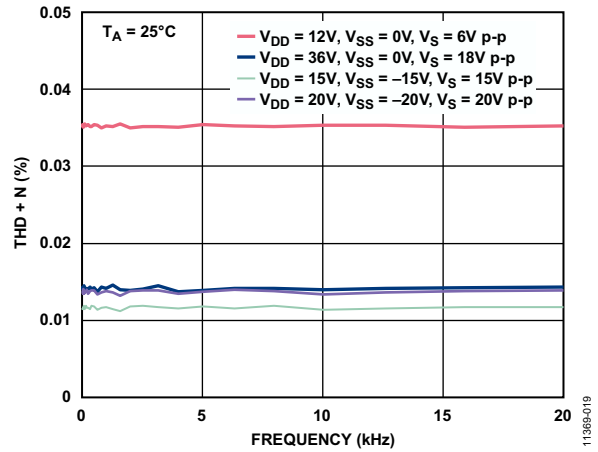

Figure 19. THD + N vs. Frequency

11369-019

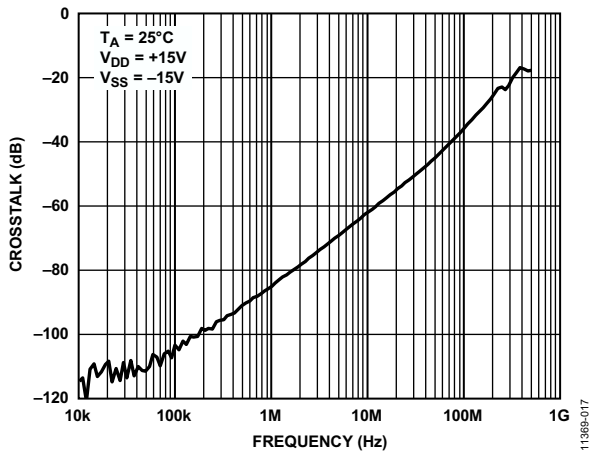

Figure 17. Crosstalk vs. Frequency

11369-017

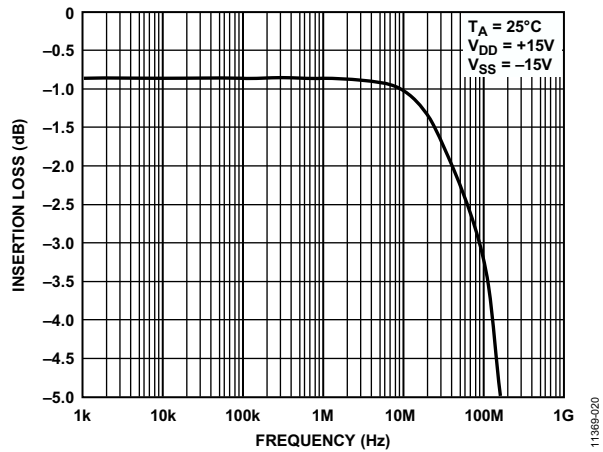

Figure 20. Bandwidth

11369-020

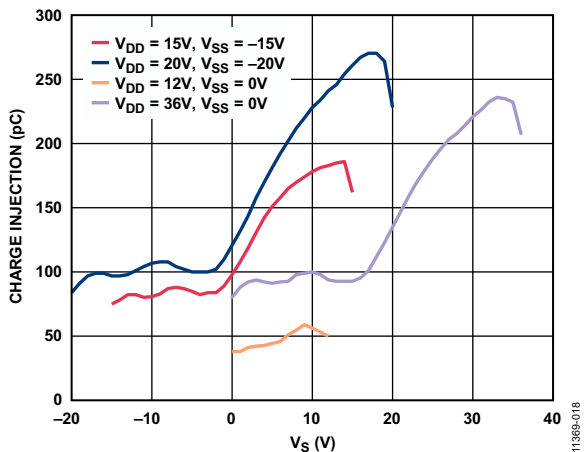

Figure 18. Charge Injection vs. Source Voltage ( $V_s$ )

11369-018

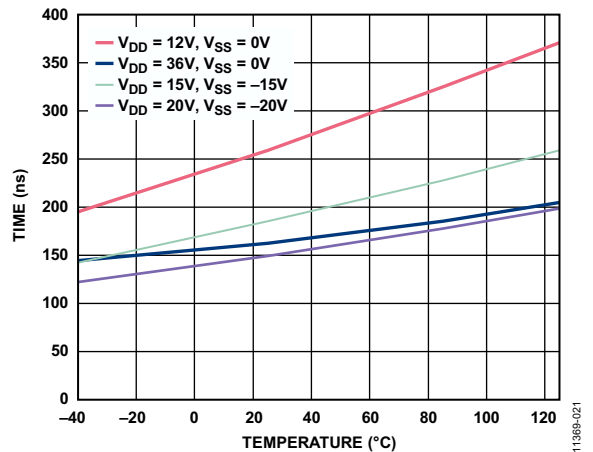

Figure 21.  $t_{\text{TRANSITION}}$  Times vs. Temperature

11369-021

TEST CIRCUITS

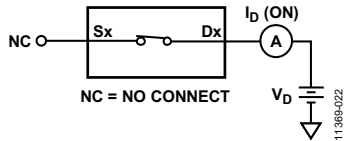

Figure 22. On Leakage

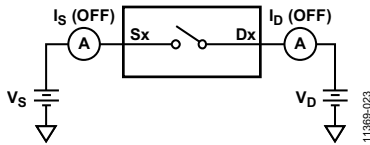

Figure 23. Off Leakage

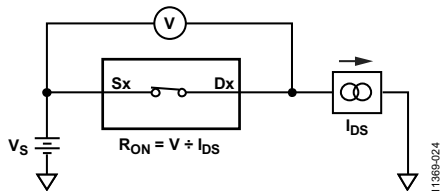
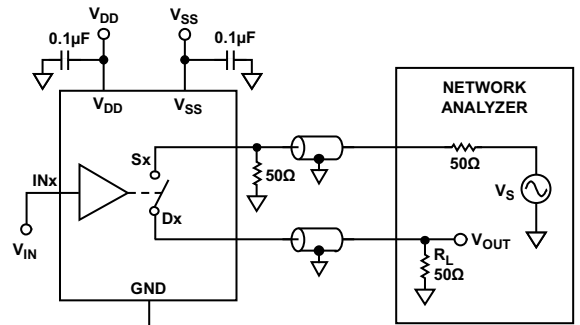

Figure 24. On Resistance



$$\text{OFF ISOLATION} = 20 \log \frac{V_{\text{OUT}}}{V_S}$$

Figure 25. Off Isolation

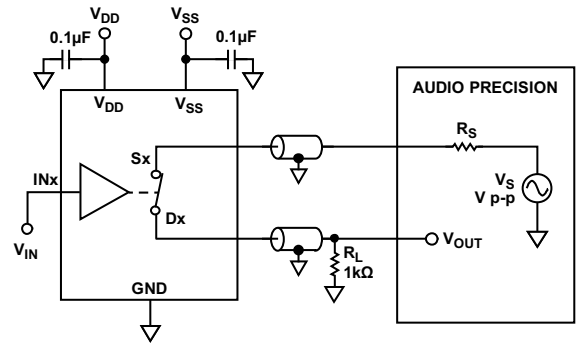
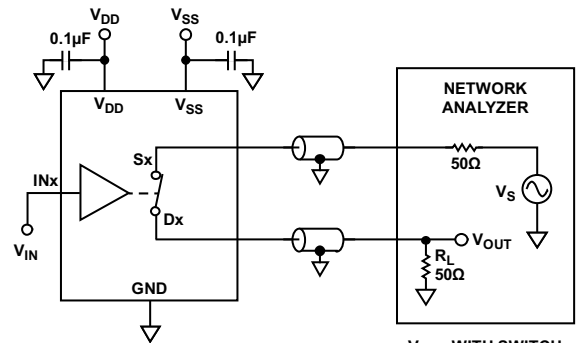

Figure 26. THD + Noise



$$\text{INSERTION LOSS} = 20 \log \frac{V_{\text{OUT WITH SWITCH}}}{V_{\text{OUT WITHOUT SWITCH}}}$$

Figure 27. Bandwidth

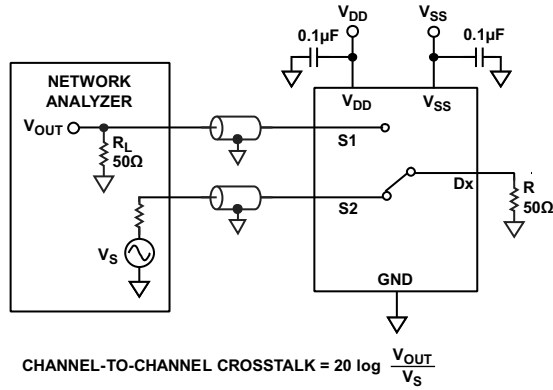

Figure 28. Channel-to-Channel Crosstalk

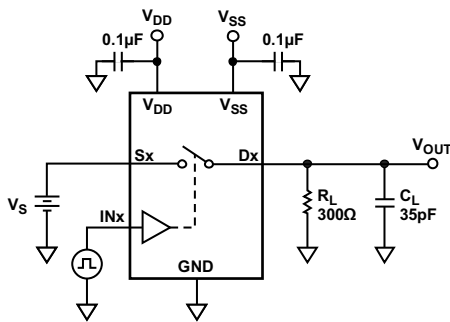
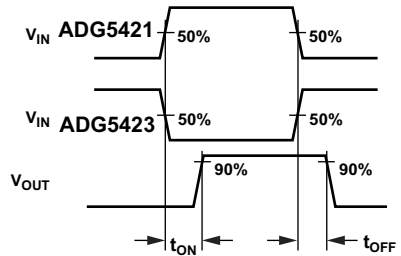

Figure 29. Switching Times,  $t_{\text{ON}}$  and  $t_{\text{OFF}}$



011369-029

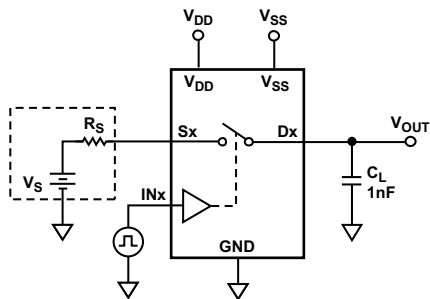
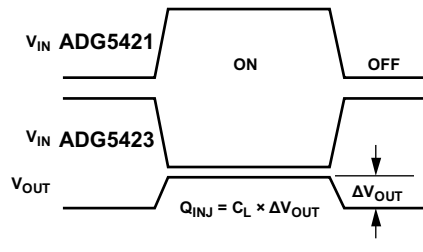

Figure 30. Charge Injection



11369-030

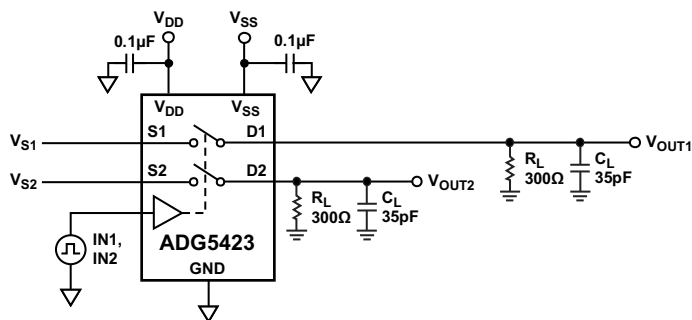
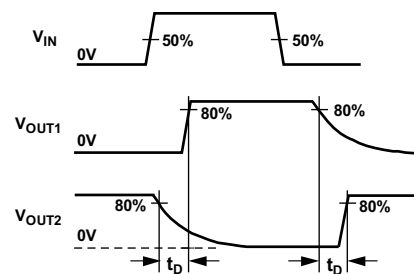

Figure 31. Break-Before-Make Time Delay



11369-031

## TERMINOLOGY

### $I_{DD}$

$I_{DD}$  represents the positive supply current.

### $I_{SS}$

$I_{SS}$  represents the negative supply current.

### $V_D, V_S$

$V_D$  and  $V_S$  represent the analog voltage on Terminal D and Terminal S, respectively.

### $R_{ON}$

$R_{ON}$  is the ohmic resistance between Terminal D and Terminal S.

### $\Delta R_{ON}$

$\Delta R_{ON}$  represents the difference between the  $R_{ON}$  of any two channels.

### $R_{FLAT(ON)}$

$R_{FLAT(ON)}$  represents the difference between the maximum and minimum value of on resistance as measured over the specified analog signal range.

### $I_S$ (Off)

$I_S$  (Off) is the source leakage current with the switch off.

### $I_D$ (Off)

$I_D$  (Off) is the drain leakage current with the switch off.

### $I_D$ (On), $I_S$ (On)

$I_D$  (On) and  $I_S$  (On) represent the channel leakage currents with the switch on.

### $V_{INL}$

$V_{INL}$  is the maximum input voltage for Logic 0.

### $V_{INH}$

$V_{INH}$  is the minimum input voltage for Logic 1.

### $I_{INL}, I_{INH}$

$I_{INL}$  and  $I_{INH}$  represent the low and high input currents of the digital inputs.

### $C_D$ (Off)

$C_D$  (Off) represents the off switch drain capacitance, which is measured with reference to ground.

### $C_S$ (Off)

$C_S$  (Off) represents the off switch source capacitance, which is measured with reference to ground.

### $C_D$ (On), $C_S$ (On)

$C_D$  (On) and  $C_S$  (On) represent on switch capacitances, which are measured with reference to ground.

### $C_{IN}$

$C_{IN}$  represents digital input capacitance.

### $t_{ON}$

$t_{ON}$  represents the delay time between the 50% and 90% points of the digital input and switch on condition.

### $t_{OFF}$

$t_{OFF}$  represents the delay time between the 50% and 90% points of the digital input and switch off condition.

### $t_D$

$t_D$  represents the off time measured between the 80% point of both switches when switching from one address state to another.

### Off Isolation

Off isolation is a measure of unwanted signal coupling through an off channel.

### Charge Injection

Charge injection is a measure of the glitch impulse transferred from the digital input to the analog output during switching.

### Crosstalk

Crosstalk is a measure of unwanted signal that is coupled through from one channel to another as a result of parasitic capacitance.

### Bandwidth

Bandwidth is the frequency at which the output is attenuated by 3 dB from its dc level.

### Total Harmonic Distortion + Noise (THD + N)

The ratio of the harmonic amplitude plus noise of the signal to the fundamental is represented by THD + N.

## APPLICATIONS INFORMATION

The [ADG54xx](#) family of switches and multiplexers provide a robust solution for instrumentation, industrial, aerospace, and other harsh environments that are prone to latch-up, which is an undesirable high current state that can lead to device failure and persists until the power supply is turned off. The [ADG5421/ADG5423](#) high voltage switches allow single-supply operation from 9 V to 40 V and dual-supply operation from  $\pm 9$  V to  $\pm 22$  V. The [ADG5421/ADG5423](#) (as well as other select devices within this family) achieve an 8 kV human body model ESD rating, which provides a robust solution, eliminating the need for separate protection circuitry designs in some applications.

### TRENCH ISOLATION

In the [ADG5421/ADG5423](#), an insulating oxide layer (trench) is placed between the NMOS and the PMOS transistors of each CMOS switch. Parasitic junctions, which occur between the transistors in junction-isolated switches, are eliminated, and the result is a completely latch-up immune switch.

In junction isolation, the N and P wells of the PMOS and NMOS transistors form a diode that is reverse-biased under normal operation. However, during overvoltage conditions, this diode can become forward-biased. The two transistors form a silicon-controlled rectifier (SCR) type circuit, causing a significant amplification of the current that, in turn, leads to latch-up. With trench isolation, this diode is removed, and the result is a latch-up immune switch.

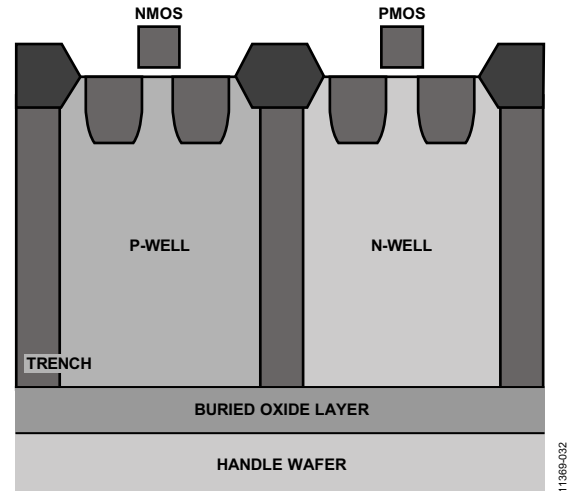
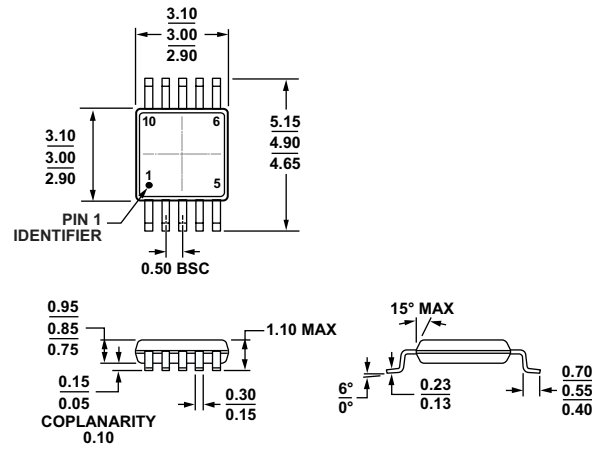

Figure 32. Trench Isolation

11388-032



### OUTLINE DIMENSIONS



COMPLIANT TO JEDEC STANDARDS MO-187-BA

Figure 33. 10-Lead Mini Small Outline Package [MSOP] (RM-10)

Dimensions shown in millimeters

091708-A

### ORDERING GUIDE

Model <sup>1</sup>	Temperature Range	Package Description	Package Option	Branding
ADG5421BRMZ	-40°C to +125°C	10-Lead Mini Small Outline Package [MSOP]	RM-10	S47
ADG5421BRMZ-RL7	-40°C to +125°C	10-Lead Mini Small Outline Package [MSOP]	RM-10	S47
ADG5423BRMZ	-40°C to +125°C	10-Lead Mini Small Outline Package [MSOP]	RM-10	S3D
ADG5423BRMZ-RL7	-40°C to +125°C	10-Lead Mini Small Outline Package [MSOP]	RM-10	S3D

<sup>1</sup> Z = RoHS Compliant Part.

**NOTES**

**NOTES**

**NOTES**