

# DIGITRON SEMICONDUCTORS

## MPU6027-MPU6028

## PROGRAMMABLE UNIJUNCTION TRANSISTORS

Available Non-RoHS (standard) or RoHS compliant (add PBF suffix).

Available as "HR" (high reliability) screened per MIL-PRF-19500, JANTX level. Add "HR" suffix to base part number.

### MAXIMUM RATINGS

Rating	Symbol	Value	Unit
<b>Power dissipation</b> Derate above 25°C	$P_F$ $1/\theta_{JA}$	375 5.0	mW mW/°C
<b>DC forward anode current</b> Derate above 25°C	$I_T$	200 2.67	mA mA/°C
<b>DC gate current</b>	$I_G$	±50	mA
<b>Repetitive peak forward current</b> 100µs pulse width, 1.0% duty cycle 20µs pulse width, 1.0% duty cycle	$I_{TRM}$	1.0 2.0	Amp
<b>Non-repetitive peak forward current</b> 10µs pulse width	$I_{TSM}$	5.0	Amp
<b>Gate to cathode forward voltage</b>	$V_{GKF}$	40	Volts
<b>Gate to cathode reverse voltage</b>	$V_{GKR}$	-5.0	Volts
<b>Gate to anode reverse voltage</b>	$V_{GAR}$	40	Volts
<b>Anode to cathode voltage</b>	$V_{AK}$	±40	Volts
<b>Operating junction temperature range</b>	$T_J$	-50 to 100	°C
<b>Storage temperature range</b>	$T_{stg}$	-55 to 150	°C

### ELECTRICAL CHARACTERISTICS ( $T_A = 25^\circ\text{C}$ unless otherwise noted)

Characteristic		Symbol	Min	Typ	Max	Unit
<b>Peak current</b> ( $V_S = 10\text{Vdc}$ , $R_G = 1.0\text{M}\Omega$ )  ( $V_S = 10\text{Vdc}$ , $R_G = 10\text{k}\Omega$ )	MPU6027 MPU6028 MPU6027 MPU6028	$I_P$	- - - -	1.25 0.08 4.0 0.70	2.0 0.15 5.0 1.0	$\mu\text{A}$
<b>Off set voltage</b> ( $V_S = 10\text{Vdc}$ , $R_G = 1.0\text{M}\Omega$ )  ( $V_S = 10\text{Vdc}$ , $R_G = 10\text{k}\Omega$ )	MPU6027 MPU6028 (all types)	$V_T$	0.2 0.2 0.2	0.70 0.50 0.35	1.6 0.6 0.6	Volts
<b>Valley current</b> ( $V_S = 10\text{Vdc}$ , $R_G = 1.0\text{M}\Omega$ )  ( $V_S = 10\text{Vdc}$ , $R_G = 10\text{k}\Omega$ )	MPU6027 MPU6028 MPU6027 MPU6028	$I_V$	- - 70 25	18 18 270 270	50 25 - -	$\mu\text{A}$
<b>Gate to anode leakage current</b> ( $V_S = 40\text{Vdc}$ , $T_A = 25^\circ\text{C}$ , cathode open) ( $V_S = 40\text{Vdc}$ , $T_A = 75^\circ\text{C}$ , cathode open)		$I_{GAO}$	- -	1.0 3.	10 -	nAdc
<b>Gate to cathode leakage current</b> ( $V_S = 40\text{Vdc}$ , anode to cathode shorted)		$I_{GKS}$	-	5.0	50	nAdc
<b>Forward voltage</b> ( $I_F = 50\text{mA}$ peak)		$V_F$	-	0.8	1.5	Volts
<b>Peak output voltage</b> ( $V_B = 20\text{Vdc}$ , $C_C = 0.2\mu\text{F}$ )		$V_O$	6.0	11	-	Volts
<b>Pulse voltage rise time</b> ( $V_B = 20\text{Vdc}$ , $C_C = 0.2\mu\text{F}$ )		$t_r$	-	40	80	ns

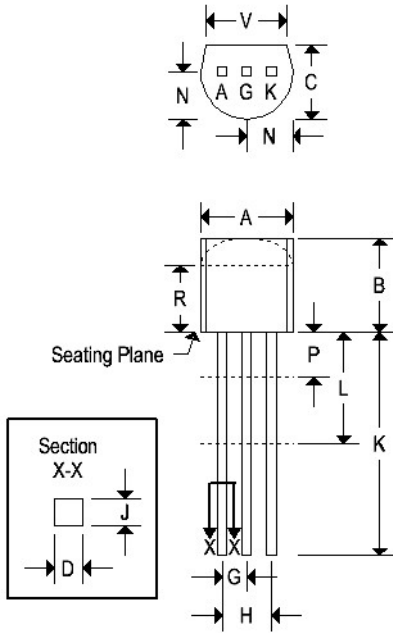
# DIGITRON SEMICONDUCTORS

MPU6027-MPU6028

PROGRAMMABLE UNIJUNCTION TRANSISTORS

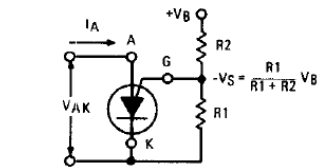
## MECHANICAL CHARACTERISTICS

Case	TO-92
Marking	Body painted, alpha-numeric
Pin out	See below

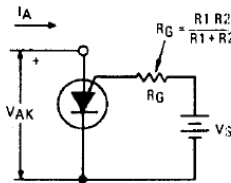


Dim	TO-92			
	Inches		Millimeters	
	Min	Max	Min	Max
A	0.175	0.205	4.450	5.200
B	0.170	0.210	4.320	5.330
C	0.125	0.165	3.180	4.190
D	0.016	0.021	0.407	0.533
G	0.045	0.055	1.150	1.390
H	0.095	0.105	2.420	2.660
J	0.015	0.020	0.390	0.500
K	0.500	-	12.700	-
L	0.250	-	6.350	-
N	0.080	0.105	2.040	2.660
P	-	0.100	-	2.540
R	0.115	-	2.930	-
V	0.135	-	3.430	-

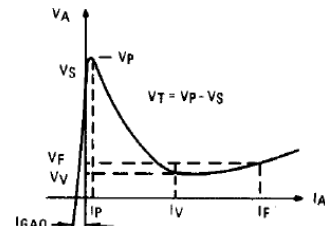
## ELECTRICAL CHARACTERIZATION



1A - PROGRAMMABLE UNIJUNCTION WITH "PROGRAM" RESISTORS R1 and R2

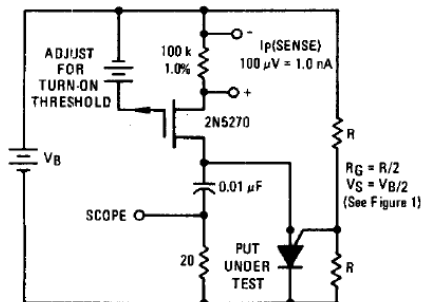


1B - EQUIVALENT TEST CIRCUIT FOR FIGURE 1A USED FOR ELECTRICAL CHARACTERISTICS TESTING (ALSO SEE FIGURE 2)

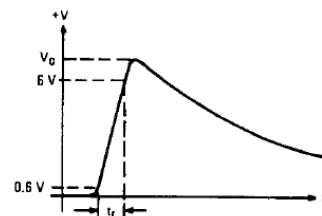
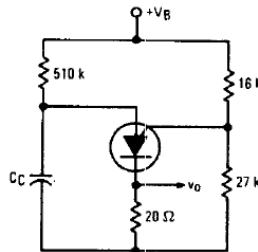


1C - ELECTRICAL CHARACTERISTICS

## PEAK CURRENT (Ip) TEST CIRCUIT



## VO AND tr TEST CIRCUIT

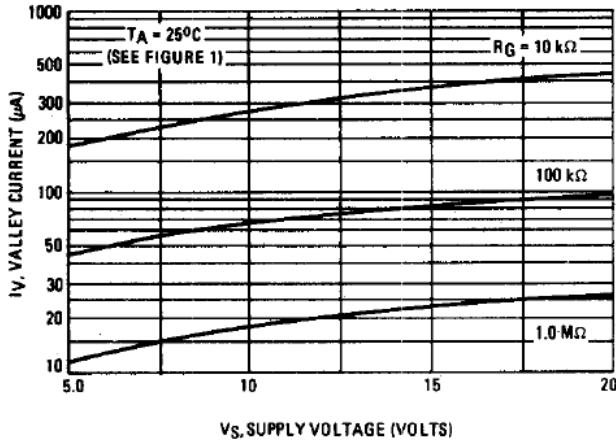


# DIGITRON SEMICONDUCTORS

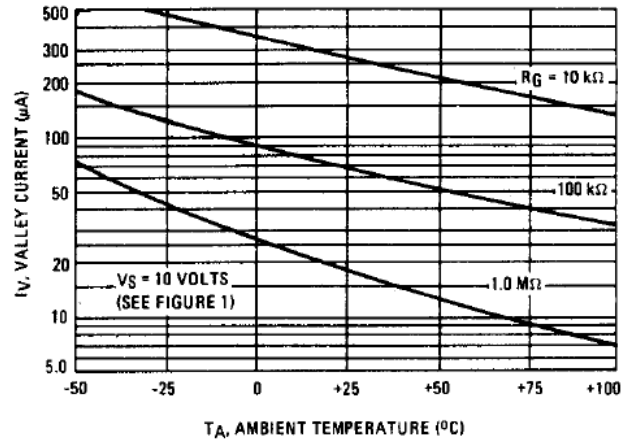
## MPU6027-MPU6028      PROGRAMMABLE UNIJUNCTION TRANSISTORS

### TYPICAL VALLEY CURRENT BEHAVIOR

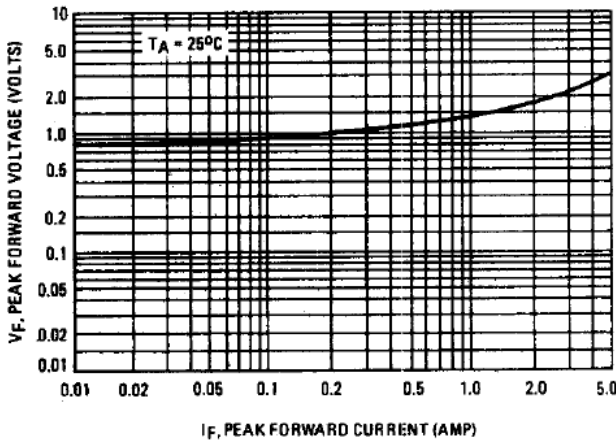
**FIGURE 4 – EFFECT OF SUPPLY VOLTAGE**



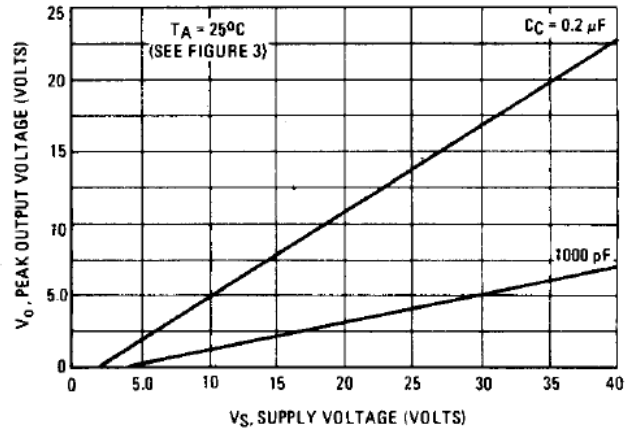
**FIGURE 5 – EFFECT OF TEMPERATURE**



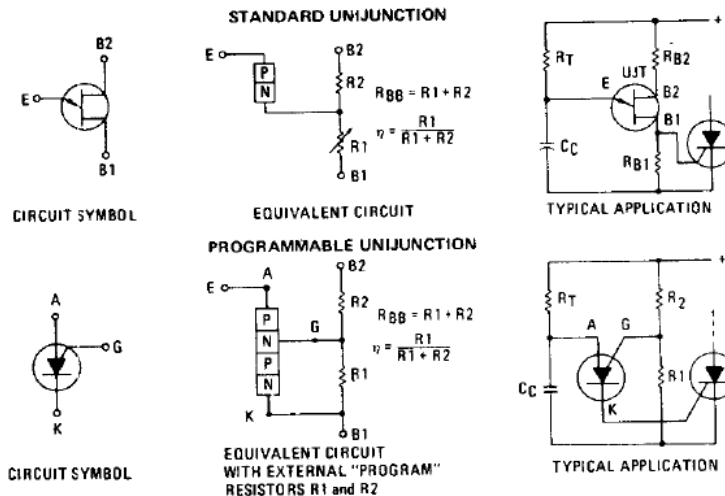
**FIGURE 6 – FORWARD VOLTAGE**



**FIGURE 7 – PEAK OUTPUT VOLTAGE**



**FIGURE 8 – STANDARD UNIJUNCTION COMPARED TO PROGRAMMABLE UNIJUNCTION**



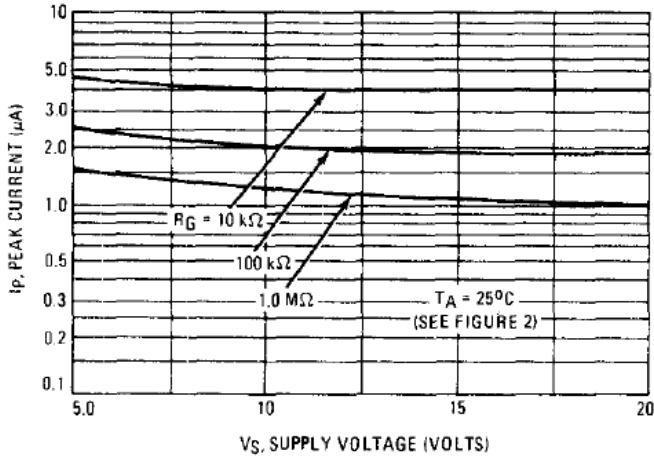
# DIGITRON SEMICONDUCTORS

## MPU6027-MPU6028      PROGRAMMABLE UNIJUNCTION TRANSISTORS

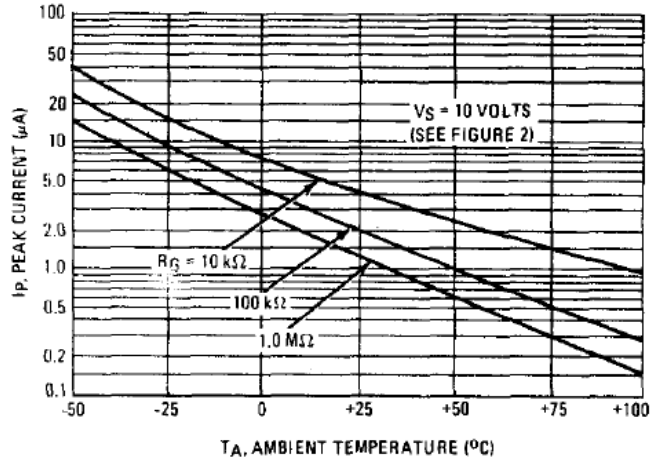
### TYPICAL PEAK CURRENT BEHAVIOR

#### MPU6027

**FIGURE 9 – EFFECT OF SUPPLY VOLTAGE AND  $R_G$**

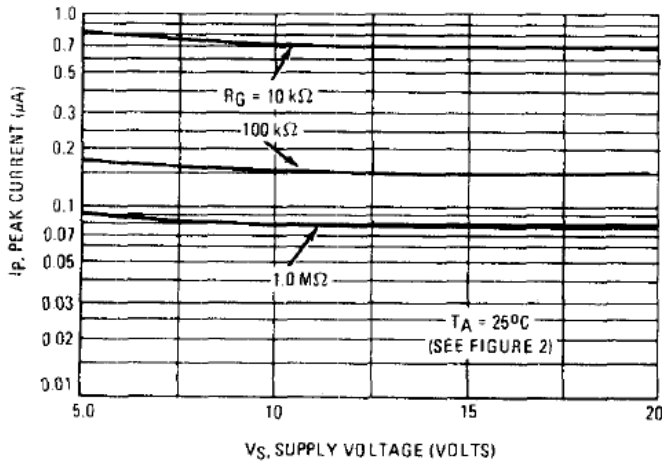


**FIGURE 10 – EFFECT OF TEMPERATURE AND  $R_G$**



#### MPU6028

**FIGURE 11 – EFFECT OF SUPPLY VOLTAGE AND  $R_G$**



**FIGURE 12 – EFFECT OF TEMPERATURE AND  $R_G$**

