



MACRONIX
INTERNATIONAL Co., LTD.

MX29LV320E T/B

MX29LV320E T/B

DATASHEET

Contents

FEATURES	5
GENERAL DESCRIPTION	6
PIN CONFIGURATION	7
PIN DESCRIPTION	8
BLOCK DIAGRAM	9
BLOCK DIAGRAM DESCRIPTION	10
BLOCK STRUCTURE	11
Table 1.a: MX29LV320ET SECTOR GROUP ARCHITECTURE.....	11
Table 1.b: MX29LV320EB SECTOR GROUP ARCHITECTURE	13
BUS OPERATION	15
Table 2-1. BUS OPERATION	15
Table 2-2. BUS OPERATION	16
FUNCTIONAL OPERATION DESCRIPTION	17
READ OPERATION	17
WRITE OPERATION.....	17
DEVICE RESET	17
STANDBY MODE.....	17
OUTPUT DISABLE	17
BYTE/WORD SELECTION	18
HARDWARE WRITE PROTECT.....	18
ACCELERATED PROGRAMMING OPERATION	18
TEMPORARY SECTOR GROUP UNPROTECT OPERATION	18
SECTOR GROUP PROTECT OPERATION	18
CHIP UNPROTECT OPERATION.....	19
AUTOMATIC SELECT BUS OPERATIONS.....	19
SECTOR LOCK STATUS VERIFICATION	19
READ SILICON ID MANUFACTURER CODE.....	19
READ SILICON ID MX29LV320ET CODE.....	19
READ SILICON ID MX29LV320EB CODE.....	19
READ INDICATOR BIT (Q7) FOR SECURITY SECTOR	20
INHERENT DATA PROTECTION.....	20
COMMAND COMPLETION.....	20
LOW VCC WRITE INHIBIT	20
WRITE PULSE "GLITCH" PROTECTION.....	20
LOGICAL INHIBIT	20
POWER-UP SEQUENCE	20
POWER-UP WRITE INHIBIT	21
POWER SUPPLY DECOUPLING	21

COMMAND OPERATIONS	22
TABLE 3. MX29LV320E T/B COMMAND DEFINITIONS	22
AUTOMATIC PROGRAMMING OF THE MEMORY ARRAY	23
SECTOR ERASE	24
CHIP ERASE.....	25
SECTOR ERASE SUSPEND.....	25
SECTOR ERASE RESUME.....	26
AUTOMATIC SELECT OPERATIONS	26
AUTOMATIC SELECT COMMAND SEQUENCE	26
READ MANUFACTURER ID OR DEVICE ID	27
SECURITY SECTOR LOCK STATUS.....	27
VERIFY SECTOR GROUP PROTECTION.....	27
SECURITY SECTOR FLASH MEMORY REGION	27
FACTORY LOCKED: SECURITY SECTOR PROGRAMMED AND PROTECTED AT THE FACTORY	27
CUSTOMER LOCKABLE: SECURITY SECTOR NOT PROGRAMMED OR PROTECTED AT THE FACTORY.....	28
ENTER AND EXIT SECURITY SECTOR.....	28
RESET OPERATION	29
COMMON FLASH MEMORY INTERFACE (CFI) MODE	30
QUERY COMMAND AND COMMAND FLASH MEMORY INTERFACE (CFI) MODE	30
Table 4-1. CFI mode: Identification Data Values	30
Table 4-2. CFI Mode: System Interface Data Values	30
Table 4-3. CFI Mode: Device Geometry Data Values.....	31
Table 4-4. CFI Mode: Primary Vendor-Specific Extended Query Data Values.....	32
ELECTRICAL CHARACTERISTICS	33
ABSOLUTE MAXIMUM STRESS RATINGS.....	33
OPERATING TEMPERATURE AND VOLTAGE.....	33
DC CHARACTERISTICS	34
SWITCHING TEST CIRCUIT	35
SWITCHING TEST WAVEFORM.....	35
AC CHARACTERISTICS	36
WRITE COMMAND OPERATION	37
Figure 1. COMMAND WRITE OPERATION.....	37
READ/RESET OPERATION	38
Figure 2. READ TIMING WAVEFORM.....	38
Figure 3. RESET# TIMING WAVEFORM.....	39
ERASE/PROGRAM OPERATION	40
Figure 4. AUTOMATIC CHIP ERASE TIMING WAVEFORM	40
Figure 5. AUTOMATIC CHIP ERASE ALGORITHM FLOWCHART	41
Figure 6. AUTOMATIC SECTOR ERASE TIMING WAVEFORM	42
Figure 7. AUTOMATIC SECTOR ERASE ALGORITHM FLOWCHART	43
Figure 8. ERASE SUSPEND/RESUME FLOWCHART	44



Figure 9. AUTOMATIC PROGRAM TIMING WAVEFORM..... 45

Figure 10. ACCELERATED PROGRAM TIMING DIAGRAM 45

Figure 11. CE# CONTROLLED WRITE TIMING WAVEFORM..... 46

Figure 12. AUTOMATIC PROGRAMMING ALGORITHM FLOWCHART..... 47

SECTOR GROUP PROTECT/CHIP UNPROTECT 48

Figure 13. SECTOR GROUP PROTECT/CHIP UNPROTECT WAVEFORM (RESET# Control) 48

Figure 14. IN-SYSTEM SECTOR GROUP PROTECT WITH RESET#=Vhv 49

Figure 15. CHIP UNPROTECT ALGORITHM WITH RESET#=Vhv..... 50

Table 5. TEMPORARY SECTOR GROUP UNPROTECT..... 51

Figure 16. TEMPORARY SECTOR GROUP UNPROTECT WAVEFORM 51

Figure 17. TEMPORARY SECTOR GROUP UNPROTECT FLOWCHART 52

Figure 18. SILICON ID READ TIMING WAVEFORM..... 53

WRITE OPERATION STATUS 54

Figure 19. DATA# POLLING TIMING WAVEFORM (DURING AUTOMATIC ALGORITHM)..... 54

Figure 20. DATA# POLLING ALGORITHM 55

Figure 21. TOGGLE BIT TIMING WAVEFORM (DURING AUTOMATIC ALGORITHM)..... 56

Figure 22. TOGGLE BIT ALGORITHM..... 57

Figure 23. BYTE# TIMING WAVEFORM FOR READ OPERATIONS (BYTE# switching from byte mode to word mode) 58

RECOMMENDED OPERATING CONDITIONS 59

ERASE AND PROGRAMMING PERFORMANCE 60

DATA RETENTION 60

LATCH-UP CHARACTERISTICS 60

TSOP PIN CAPACITANCE 60

ORDERING INFORMATION 61

PART NAME DESCRIPTION 62

PACKAGE INFORMATION..... 63

REVISION HISTORY 67

32M-BIT [4M x 8 / 2M x 16] 3V SUPPLY FLASH MEMORY

FEATURES

GENERAL FEATURES

- Byte/Word switchable
 - 4,194,304 x 8 / 2,097,152 x 16
- Sector Structure
 - 8K-Byte x 8 and 64K-Byte x 63
- Extra 256-Byte sector for security
 - Features factory locked and identifiable, and customer lockable
- Twenty-Four Sector Groups
 - Provides sector group protect function to prevent program or erase operation in the protected sector group
 - Provides chip unprotect function to allow code changing
 - Provides temporary sector group unprotect function for code changing in previously protected sector groups
- Power Supply Operation
 - Vcc 2.7 to 3.6 volt for read, erase, and program operations
- Latch-up protected to 100mA from -1V to 1.5 x Vcc
- Low Vcc write inhibit : Vcc ≤ V_{Iko}
- Compatible with JEDEC standard
 - Pinout and software compatible to single power supply Flash
- **Functional compatible with MX29LV320D T/B device**

PERFORMANCE

- High Performance
 - Fast access time: 70ns
 - Fast program time: 11us/word typical utilizing accelerate function
 - Fast erase time: 0.7s/sector, 35s/chip (typical)
- Low Power Consumption
 - Low active read current: 10mA (typical) at 5MHz
 - Low standby current: 5uA (typical)
- Typical 100,000 erase/program cycle
- 20 years data retention

SOFTWARE FEATURES

- Erase Suspend/ Erase Resume
 - Suspends sector erase operation to read data from or program data to another sector which is not being erased
- Status Reply
 - Data# Polling & Toggle bits provide detection of program and erase operation completion
- Support Common Flash Interface (CFI)

HARDWARE FEATURES

- Ready/Busy# (RY/BY#) Output
 - Provides a hardware method of detecting program and erase operation completion
- Hardware Reset (RESET#) Input
 - Provides a hardware method to reset the internal state machine to read mode
- WP#/ACC input pin
 - Provides accelerated program capability

PACKAGE

- 44-Pin SOP
- 48-Pin TSOP
- 48-Ball TFBGA (6 x 8mm)
- 48-Ball LFBGA (6 x 8mm)
- **All devices are RoHS Compliant & Halogen-free.**

GENERAL DESCRIPTION

MX29LV320E T/B is a 32Mbit flash memory that can be organized as 4Mbytes of 8 bits each or 2Mbytes of 16 bits each. These devices operate over a voltage range of 2.7V to 3.6V typically using a 3V power supply input. The memory array is divided into 64 equal 64 Kilo byte blocks. However, depending on the device being used as a Top-Boot or Bottom-Boot device, the top or the bottom first block is further subdivided into 8 equal 8Kbyte blocks. The outermost two sectors at the top or at the bottom can be protected at the boot blocks for this device. This flash memory also provides an additional factory lockable or customer lockable 256byte sector to provide security feature.

The MX29LV320E T/B is offered in a 44-pin SOP, a 48-pin TSOP and a 48-ball BGA(TFBGA/LFBGA) JEDEC standard package. These packages are offered in leaded, as well as lead-free versions that are compliant to the RoHS specifications. The software algorithm used for this device also adheres to the JEDEC standard for single power supply devices. These flash parts can be programmed in system or on commercially available EPROM/Flash programmers.

Separate OE# and CE# (Output Enable and Chip Enable) signals are provided to simplify system design. When used with high speed processors, the 70ns read access time of this flash memory permits operation with minimal time lost due to system timing delays.

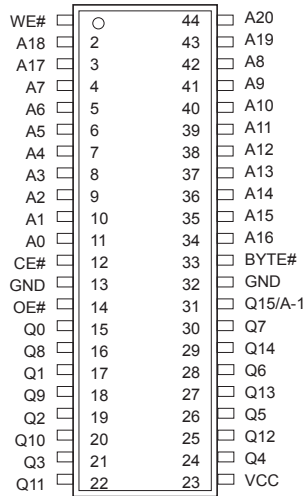
The automatic erase algorithm provided on Macronix flash memories perform an automatic program prior to program. The user only needs to provide a write command to the command register. The on-chip state machine automatically controls the program and erase functions including all necessary internal timings. Since erase operations take much longer time than read operations, erase can be interrupted to perform read operations in other sectors of the device. For this, Erase Suspend operation along with erase resume operation are provided. Data# polling or toggle bits are used to indicate the end of the erase/program operation.

These devices are manufactured at the Macronix fabrication facility using the time tested and proven Macronix's advanced technology. This proprietary non-epi process provides a very high degree of latch-up protection for stresses up to 100 milliamperes on address and data pins from -1V to 1.5xVCC.

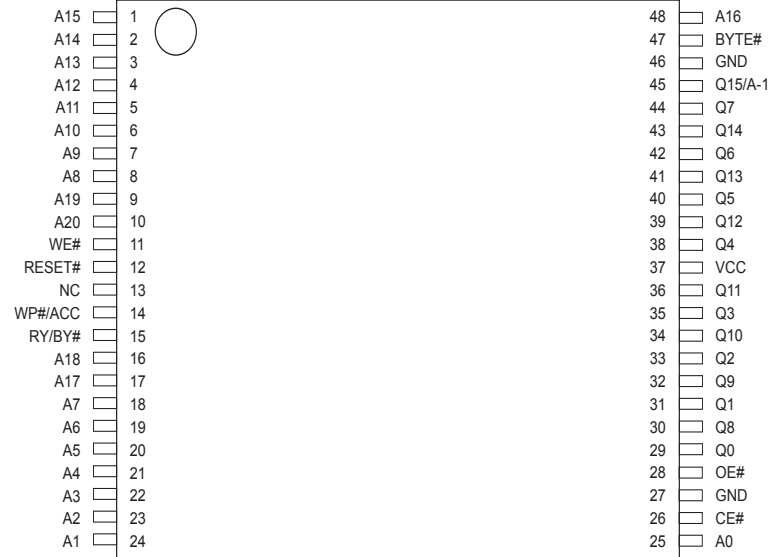
With low power consumption and enhanced hardware and software features, this flash memory retains data reliably for at least twenty years. Erase and programming functions have been tested to meet a typical specification of 100,000 cycles of operation.

PIN CONFIGURATION

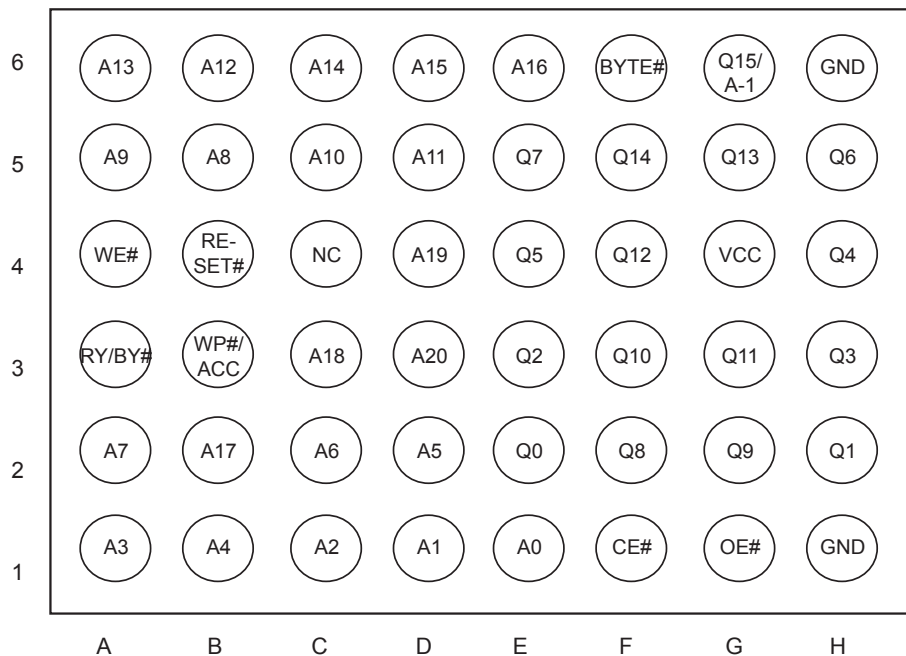
44 SOP



48 TSOP



48-Ball TFBGA/LFBGA (6mm x 8mm, Top View, Balls Facing Down)

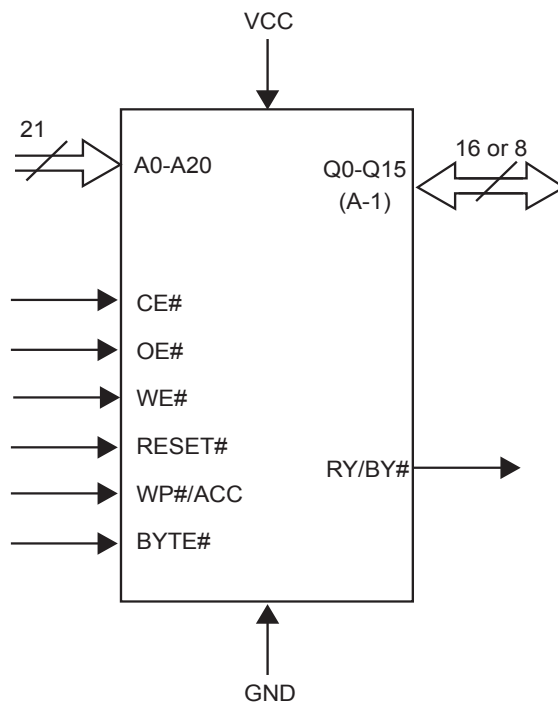


PIN DESCRIPTION

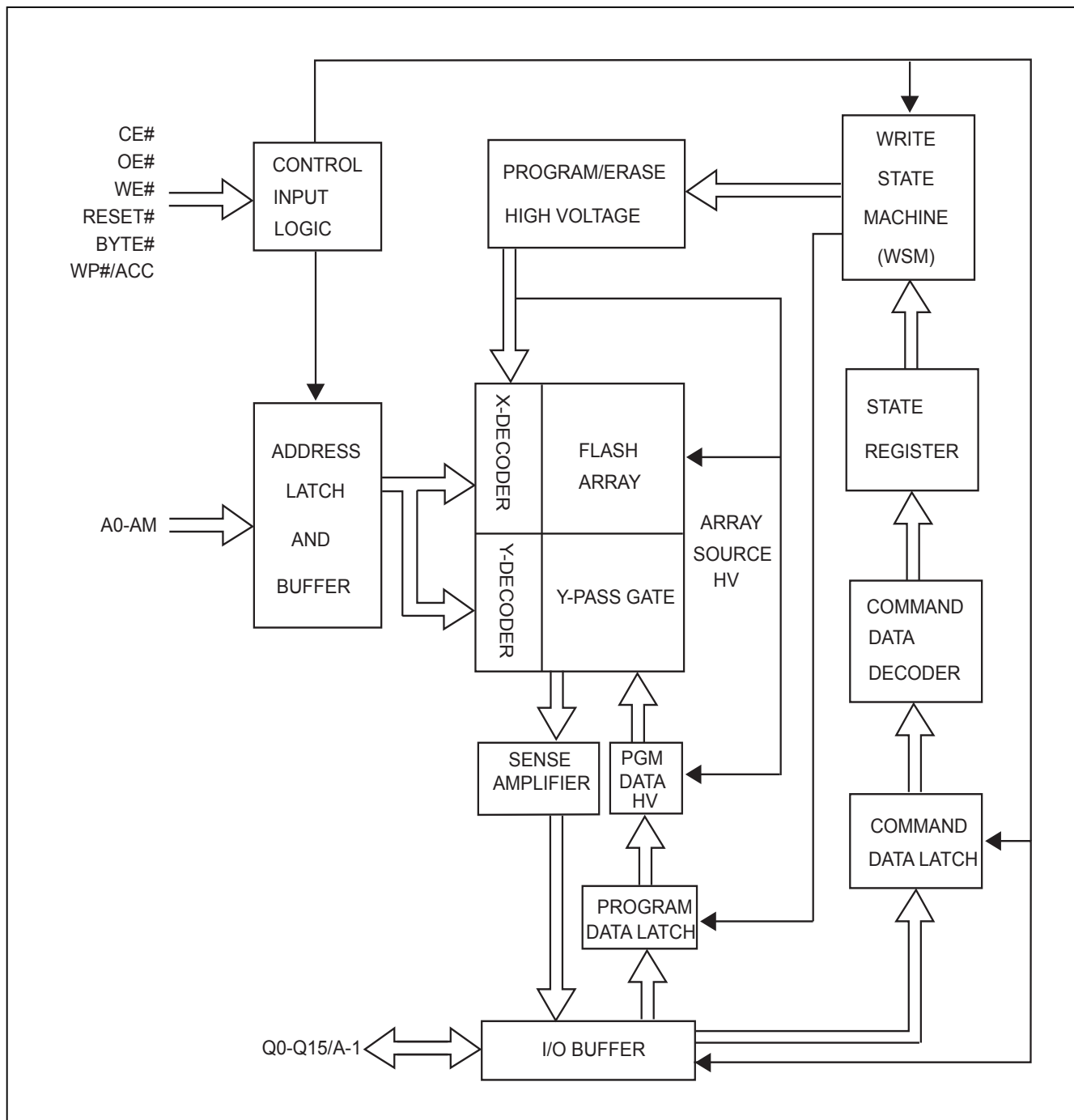
SYMBOL	PIN NAME
A0~A20	Address Input
Q0~Q14	15 Data Inputs/Outputs
Q15/A-1	Q15(Data Input/Output, word mode); A-1(LSB Address Input, byte mode)
CE#	Chip Enable Input
WE#	Write Enable Input
OE#	Output Enable Input
BYTE#	Word/Byte Selection Input
RESET#	Hardware Reset Pin, Active Low
RY/BY#	Ready/Busy Output
Vcc	3.0 volt-only single power supply
WP#/ACC	Hardware Write Protect/Acceleration Pin
GND	Device Ground
NC	Pin Not Connected Internally

Note: If customers do not need WP#/ACC feature, please connect WP#/ACC pin to VCC or let it floating. The WP#/ACC has an internal pull-up when unconnected WP#/ACC is at Vih.

LOGIC SYMBOL



BLOCK DIAGRAM



BLOCK DIAGRAM DESCRIPTION

The block diagram on Page 9 illustrates a simplified architecture of MX29LV320E T/B. Each block in the block diagram represents one or more circuit modules in the real chip used to access, erase, program, and read the memory array..

The "CONTROL INPUT LOGIC" block receives input pins CE#, OE#, WE#, RESET#, BYTE#, and WP#/ACC. It creates internal timing control signals according to the input pins and outputs to the "ADDRESS LATCH AND BUFFER" to latch the external address pins A0-AM(A20). The internal addresses are output from this block to the main array and decoders composed of "X-DECODER", "Y-DECODER", "Y-PASS GATE", and "FLASH ARRAY". The X-DECODER decodes the word-lines of the flash array, while the Y-DECODER decodes the bit-lines of the flash array. The bit lines are electrically connected to the "SENSE AMPLIFIER" and "PGM DATA HV" selectively through the y-pass gates. Sense amplifiers are used to read out the contents of the flash memory, while the "PGM DATA HV" block is used to selectively deliver high power to bit-lines during programming. The "I/O BUFFER" controls the input and output on the Q0-Q15/A-1 pads. During read operation, the I/O buffer receives data from sense amplifiers and drives the output pads accordingly. In the last cycle of program command, the I/O buffer transmits the data on Q0-Q15/A-1 to "PROGRAM DATA LATCH", which controls the high power drivers in "PGM DATA HV" to selectively program the bits in a word or byte according to the user input pattern.

The "PROGRAM/ERASE HIGH VOLTAGE" block comprises the circuits to generate and deliver the necessary high voltage to the X-DECODER, FLASH ARRAY, and "PGM DATA HV" block. The logic control module comprises of the "WRITE STATE MACHINE (WSM)", "STATE REGISTER", "COMMAND DATA DECODER", and "COMMAND DATA LATCH". When the user issues a command by toggling WE#, the command on Q0-Q15/A-1 is latched in the command data latch and is decoded by the command data decoder. The state register receives the command and records the current state of the device. The WSM implements the internal algorithms for program or erase according to the current command state by controlling each block in the block diagram.

BLOCK STRUCTURE

The main flash memory array can be organized as 4M Bytes x 8 or as 2M Words x 16. The details of the address ranges and the corresponding sector addresses are shown in Table 1. Table 1.a shows the sector group architecture for the Top Boot part, whereas Table 1.b shows the sector group architecture for the Bottom Boot part. The specific security sector addresses are shown at the bottom off each of these tables.

Table 1.a: MX29LV320ET SECTOR GROUP ARCHITECTURE

Sector Group	Sector Size		Sector	Sector Address A20-A12	Address Range	
	Byte Mode (Kbytes)	Word Mode (Kwords)			Byte Mode (x8)	Word Mode (x16)
1	64	32	SA0	000000xxx	000000h-00FFFFh	000000h-07FFFh
1	64	32	SA1	000001xxx	010000h-01FFFFh	008000h-0FFFFh
1	64	32	SA2	000010xxx	020000h-02FFFFh	010000h-17FFFh
1	64	32	SA3	000011xxx	030000h-03FFFFh	018000h-01FFFFh
2	64	32	SA4	000100xxx	040000h-04FFFFh	020000h-027FFFh
2	64	32	SA5	000101xxx	050000h-05FFFFh	028000h-02FFFFh
2	64	32	SA6	000110xxx	060000h-06FFFFh	030000h-037FFFh
2	64	32	SA7	000111xxx	070000h-07FFFFh	038000h-03FFFFh
3	64	32	SA8	001000xxx	080000h-08FFFFh	040000h-047FFFh
3	64	32	SA9	001001xxx	090000h-09FFFFh	048000h-04FFFFh
3	64	32	SA10	001010xxx	0A0000h-0AFFFFh	050000h-057FFFh
3	64	32	SA11	001011xxx	0B0000h-0BFFFFh	058000h-05FFFFh
4	64	32	SA12	001100xxx	0C0000h-0CFFFFh	060000h-067FFFh
4	64	32	SA13	001101xxx	0D0000h-0DFFFFh	068000h-06FFFFh
4	64	32	SA14	001110xxx	0E0000h-0EFFFFh	070000h-077FFFh
4	64	32	SA15	001111xxx	0F0000h-0FFFFFh	078000h-07FFFFh
5	64	32	SA16	010000xxx	100000h-10FFFFh	080000h-087FFFh
5	64	32	SA17	010001xxx	110000h-11FFFFh	088000h-08FFFFh
5	64	32	SA18	010010xxx	120000h-12FFFFh	090000h-097FFFh
5	64	32	SA19	010011xxx	130000h-13FFFFh	098000h-09FFFFh
6	64	32	SA20	010100xxx	140000h-14FFFFh	0A0000h-0A7FFFh
6	64	32	SA21	010101xxx	150000h-15FFFFh	0A8000h-0AFFFFh
6	64	32	SA22	010110xxx	160000h-16FFFFh	0B0000h-0B7FFFh
6	64	32	SA23	010111xxx	170000h-17FFFFh	0B8000h-0BFFFFh
7	64	32	SA24	011000xxx	180000h-18FFFFh	0C0000h-0C7FFFh
7	64	32	SA25	011001xxx	190000h-19FFFFh	0C8000h-0CFFFFh
7	64	32	SA26	011010xxx	1A0000h-1AFFFFh	0D0000h-0D7FFFh
7	64	32	SA27	011011xxx	1B0000h-1BFFFFh	0D8000h-0DFFFFh
8	64	32	SA28	011100xxx	1C0000h-1CFFFFh	0E0000h-0E7FFFh
8	64	32	SA29	011101xxx	1D0000h-1DFFFFh	0E8000h-0EFFFFh
8	64	32	SA30	011110xxx	1E0000h-1EFFFFh	0F0000h-0F7FFFh
8	64	32	SA31	011111xxx	1F0000h-1FFFFFh	0F8000h-0FFFFFh
9	64	32	SA32	100000xxx	200000h-20FFFFh	100000h-107FFFh
9	64	32	SA33	100001xxx	210000h-21FFFFh	108000h-10FFFFh
9	64	32	SA34	100010xxx	220000h-22FFFFh	110000h-117FFFh



Sector Group	Sector Size		Sector	Sector Address A20-A12	Address Range	
	Byte Mode (Kbytes)	Word Mode (Kwords)			Byte Mode (x8)	Word Mode (x16)
9	64	32	SA35	100011xxx	230000h-23FFFFh	118000h-11FFFFh
10	64	32	SA36	100100xxx	240000h-24FFFFh	120000h-127FFFh
10	64	32	SA37	100101xxx	250000h-25FFFFh	128000h-12FFFFh
10	64	32	SA38	100110xxx	260000h-26FFFFh	130000h-137FFFh
10	64	32	SA39	100111xxx	270000h-27FFFFh	138000h-13FFFFh
11	64	32	SA40	101000xxx	280000h-28FFFFh	140000h-147FFFh
11	64	32	SA41	101001xxx	290000h-29FFFFh	148000h-14FFFFh
11	64	32	SA42	101010xxx	2A0000h-2AFFFFh	150000h-157FFFh
11	64	32	SA43	101011xxx	2B0000h-2BFFFFh	158000h-15FFFFh
12	64	32	SA44	101100xxx	2C0000h-2CFFFFh	160000h-167FFFh
12	64	32	SA45	101101xxx	2D0000h-2DFFFFh	168000h-16FFFFh
12	64	32	SA46	101110xxx	2E0000h-2EFFFFh	170000h-177FFFh
12	64	32	SA47	101111xxx	2F0000h-2FFFFFh	178000h-17FFFFh
13	64	32	SA48	110000xxx	300000h-30FFFFh	180000h-187FFFh
13	64	32	SA49	110001xxx	310000h-31FFFFh	188000h-18FFFFh
13	64	32	SA50	110010xxx	320000h-32FFFFh	190000h-197FFFh
13	64	32	SA51	110011xxx	330000h-33FFFFh	198000h-19FFFFh
14	64	32	SA52	110100xxx	340000h-34FFFFh	1A0000h-1A7FFFh
14	64	32	SA53	110101xxx	350000h-35FFFFh	1A8000h-1AFFFFh
14	64	32	SA54	110110xxx	360000h-36FFFFh	1B0000h-1B7FFFh
14	64	32	SA55	110111xxx	370000h-37FFFFh	1B8000h-1BFFFFh
15	64	32	SA56	111000xxx	380000h-38FFFFh	1C0000h-1C7FFFh
15	64	32	SA57	111001xxx	390000h-39FFFFh	1C8000h-1CFFFFh
15	64	32	SA58	111010xxx	3A0000h-3AFFFFh	1D0000h-1D7FFFh
15	64	32	SA59	111011xxx	3B0000h-3BFFFFh	1D8000h-1DFFFFh
16	64	32	SA60	111100xxx	3C0000h-3CFFFFh	1E0000h-1E7FFFh
16	64	32	SA61	111101xxx	3D0000h-3DFFFFh	1E8000h-1EFFFFh
16	64	32	SA62	111110xxx	3E0000h-3EFFFFh	1F0000h-1F7FFFh
17	8	4	SA63	111111000	3F0000h-3F1FFFh	1F8000h-1F8FFFh
18	8	4	SA64	111111001	3F2000h-3F3FFFh	1F9000h-1F9FFFh
19	8	4	SA65	111111010	3F4000h-3F5FFFh	1FA000h-1FAFFFh
20	8	4	SA66	111111011	3F6000h-3F7FFFh	1FB000h-1FBFFFh
21	8	4	SA67	111111100	3F8000h-3F9FFFh	1FC000h-1FCFFFh
22	8	4	SA68	111111101	3FA000h-3FBFFFh	1FD000h-1FDFFFh
23	8	4	SA69	111111110	3FC000h-3FDFFFh	1FE000h-1FEFFFh
24	8	4	SA70	111111111	3FE000h-3FFFFFh	1FF000h-1FFFFFh

Top Boot Security Sector Addresses

Sector Size		Address Range	
Byte Mode (bytes)	Word Mode (words)	Byte Mode (x8)	Word Mode (x16)
256	128	3F0000h-3F00FFh	1F8000h-1F807Fh

Table 1.b: MX29LV320EB SECTOR GROUP ARCHITECTURE

Sector Group	Sector Size		Sector	Sector Address A20-A12	Address Range	
	Byte Mode (Kbytes)	Word Mode (Kwords)			Byte Mode (x8)	Word Mode (x16)
1	8	4	SA0	00000000	00000h-001FFFh	00000h-000FFFh
2	8	4	SA1	00000001	002000h-003FFFh	001000h-001FFFh
3	8	4	SA2	00000010	004000h-005FFFh	002000h-002FFFh
4	8	4	SA3	00000011	006000h-007FFFh	003000h-003FFFh
5	8	4	SA4	00000100	008000h-009FFFh	004000h-004FFFh
6	8	4	SA5	00000101	00A000h-00BFFFh	005000h-005FFFh
7	8	4	SA6	00000110	00C000h-00DFFFh	006000h-006FFFh
8	8	4	SA7	00000111	00E000h-00FFFFh	007000h-007FFFh
9	64	32	SA8	000001xxx	010000h-01FFFFh	008000h-00FFFFh
9	64	32	SA9	000010xxx	020000h-02FFFFh	010000h-017FFFh
9	64	32	SA10	000011xxx	030000h-03FFFFh	018000h-01FFFFh
10	64	32	SA11	000100xxx	040000h-04FFFFh	020000h-027FFFh
10	64	32	SA12	000101xxx	050000h-05FFFFh	028000h-02FFFFh
10	64	32	SA13	000110xxx	060000h-06FFFFh	030000h-037FFFh
10	64	32	SA14	000111xxx	070000h-07FFFFh	038000h-03FFFFh
11	64	32	SA15	001000xxx	080000h-08FFFFh	040000h-047FFFh
11	64	32	SA16	001001xxx	090000h-09FFFFh	048000h-04FFFFh
11	64	32	SA17	001010xxx	0A0000h-0AFFFFh	050000h-057FFFh
11	64	32	SA18	001011xxx	0B0000h-0BFFFFh	058000h-05FFFFh
12	64	32	SA19	001100xxx	0C0000h-0CFFFFh	060000h-067FFFh
12	64	32	SA20	001101xxx	0D0000h-0DFFFFh	068000h-06FFFFh
12	64	32	SA21	001110xxx	0E0000h-0EFFFFh	070000h-077FFFh
12	64	32	SA22	001111xxx	0F0000h-0FFFFFh	078000h-07FFFFh
13	64	32	SA23	010000xxx	100000h-10FFFFh	080000h-087FFFh
13	64	32	SA24	010001xxx	110000h-11FFFFh	088000h-08FFFFh
13	64	32	SA25	010010xxx	120000h-12FFFFh	090000h-097FFFh
13	64	32	SA26	010011xxx	130000h-13FFFFh	098000h-09FFFFh
14	64	32	SA27	010100xxx	140000h-14FFFFh	0A0000h-0A7FFFh
14	64	32	SA28	010101xxx	150000h-15FFFFh	0A8000h-0AFFFFh
14	64	32	SA29	010110xxx	160000h-16FFFFh	0B0000h-0B7FFFh
14	64	32	SA30	010111xxx	170000h-17FFFFh	0B8000h-0BFFFFh
15	64	32	SA31	011000xxx	180000h-18FFFFh	0C0000h-0C7FFFh
15	64	32	SA32	011001xxx	190000h-19FFFFh	0C8000h-0CFFFFh
15	64	32	SA33	011010xxx	1A0000h-1AFFFFh	0D0000h-0D7FFFh
15	64	32	SA34	011011xxx	1B0000h-1BFFFFh	0D8000h-0DFFFFh
16	64	32	SA35	011100xxx	1C0000h-1CFFFFh	0E0000h-0E7FFFh
16	64	32	SA36	011101xxx	1D0000h-1DFFFFh	0E8000h-0EFFFFh
16	64	32	SA37	011110xxx	1E0000h-1EFFFFh	0F0000h-0F7FFFh
16	64	32	SA38	011111xxx	1F0000h-1FFFFFh	0F8000h-0FFFFFh
17	64	32	SA39	100000xxx	200000h-20FFFFh	100000h-107FFFh
17	64	32	SA40	100001xxx	210000h-21FFFFh	108000h-10FFFFh
17	64	32	SA41	100010xxx	220000h-22FFFFh	110000h-117FFFh



Sector Group	Sector Size		Sector	Sector Address A20-A12	Address Range	
	Byte Mode (Kbytes)	Word Mode (Kwords)			Byte Mode (x8)	Word Mode (x16)
17	64	32	SA42	100011xxx	230000h-23FFFFh	118000h-11FFFFh
18	64	32	SA43	100100xxx	240000h-24FFFFh	120000h-127FFFh
18	64	32	SA44	100101xxx	250000h-25FFFFh	128000h-12FFFFh
18	64	32	SA45	100110xxx	260000h-26FFFFh	130000h-137FFFh
18	64	32	SA46	100111xxx	270000h-27FFFFh	138000h-13FFFFh
19	64	32	SA47	101000xxx	280000h-28FFFFh	140000h-147FFFh
19	64	32	SA48	101001xxx	290000h-29FFFFh	148000h-14FFFFh
19	64	32	SA49	101010xxx	2A0000h-2AFFFFh	150000h-157FFFh
19	64	32	SA50	101011xxx	2B0000h-2BFFFFh	158000h-15FFFFh
20	64	32	SA51	101100xxx	2C0000h-2CFFFFh	160000h-167FFFh
20	64	32	SA52	101101xxx	2D0000h-2DFFFFh	168000h-16FFFFh
20	64	32	SA53	101110xxx	2E0000h-2EFFFFh	170000h-177FFFh
20	64	32	SA54	101111xxx	2F0000h-2FFFFFh	178000h-17FFFFh
21	64	32	SA55	110000xxx	300000h-30FFFFh	180000h-187FFFh
21	64	32	SA56	110001xxx	310000h-31FFFFh	188000h-18FFFFh
21	64	32	SA57	110010xxx	320000h-32FFFFh	190000h-197FFFh
21	64	32	SA58	110011xxx	330000h-33FFFFh	198000h-19FFFFh
22	64	32	SA59	110100xxx	340000h-34FFFFh	1A0000h-1A7FFFh
22	64	32	SA60	110101xxx	350000h-35FFFFh	1A8000h-1AFFFFh
22	64	32	SA61	110110xxx	360000h-36FFFFh	1B0000h-1B7FFFh
22	64	32	SA62	110111xxx	370000h-37FFFFh	1B8000h-1BFFFFh
23	64	32	SA63	111000xxx	380000h-38FFFFh	1C0000h-1C7FFFh
23	64	32	SA64	111001xxx	390000h-39FFFFh	1C8000h-1CFFFFh
23	64	32	SA65	111010xxx	3A0000h-3AFFFFh	1D0000h-1D7FFFh
23	64	32	SA66	111011xxx	3B0000h-3BFFFFh	1D8000h-1DFFFFh
24	64	32	SA67	111100xxx	3C0000h-3CFFFFh	1E0000h-1E7FFFh
24	64	32	SA68	111101xxx	3D0000h-3DFFFFh	1E8000h-1EFFFFh
24	64	32	SA69	111110xxx	3E0000h-3EFFFFh	1F0000h-1F7FFFh
24	64	32	SA70	111111xxx	3F0000h-3FFFFFh	1F8000h-1FFFFFh

Bottom Boot Security Sector Addresses

Sector Size		Address Range	
Byte Mode (bytes)	Word Mode (words)	Byte Mode (x8)	Word Mode (x16)
256	128	000000h-0000FFh	000000h-00007Fh

BUS OPERATION

Table 2-1. BUS OPERATION

Mode Select	RE-SET#	CE#	WE#	OE#	Address	Data (I/O) Q7~Q0	Byte#		WP#/ACC
							Vil	Vih	
							Q15~Q8		
Device Reset	L	X	X	X	X	HighZ	HighZ	HighZ	L/H
Standby Mode	Vcc ± 0.3V	Vcc ± 0.3V	X	X	X	HighZ	HighZ	HighZ	H
Output Disable	H	L	H	H	X	HighZ	HighZ	HighZ	L/H
Read Mode	H	L	H	L	AIN	DOUT	Q8-Q14=	DOUT	L/H
Write (Note1)	H	L	L	H	AIN	DIN	HighZ	DIN	Note3
Accelerate Program	H	L	L	H	AIN	DIN	Q15=A-1	DIN	Vhv
Temporary Sector-Group Unprotect	Vhv	X	X	X	AIN	DIN	HighZ	DIN	Note3
Sector-Group Protect (Note2)	Vhv	L	L	H	Sector Address, A6=L, A1=H, A0=L	DIN, DOUT	X	X	L/H
Chip Unprotect (Note2)	Vhv	L	L	H	Sector Address, A6=H, A1=H, A0=L	DIN, DOUT	X	X	Note3

Notes:

1. All sectors will be unprotected if WP#/ACC=Vhv.
2. The two outmost boot sectors are protected if WP#/ACC=Vil.
3. When WP#/ACC = Vih, the protection conditions of the two outmost boot sectors depend on previous protection conditions."Sector/Sector Block Protection and Unprotection" describes the protect and unprotect method.
4. Q0~Q15 are input (DIN) or output (DOUT) pins according to the requests of command sequence, sector protection, or data polling algorithm.
5. In Word Mode (Byte#=Vih), the addresses are AM to A0.
In Byte Mode (Byte#=Vil), the addresses are AM to A-1 (Q15).
6. AM: MSB of address.

Table 2-2. BUS OPERATION

Item	Control Input			AM to A12	A11 to A10	A9	A8 to A7	A6	A5 to A2	A1	A0	Q7~Q0	Q15~Q8
	CE#	WE#	OE#										
Sector Lock Status Verification	L	H	L	SA	x	V _{hv}	x	L	x	H	L	01h or 00h (Note 1)	x
Read Silicon ID Manufacturer Code	L	H	L	x	x	V _{hv}	x	L	x	L	L	C2h	x
Read Silicon ID MX29LV320ET	L	H	L	x	x	V _{hv}	x	L	x	L	H	A7h	22h(Word) x (Byte)
Read Silicon ID MX29LV320EB	L	H	L	x	x	V _{hv}	x	L	x	L	H	A8h	22h(Word) x (Byte)
Read Indicator Bit (Q7) For Security Sector	L	H	L	x	x	V _{hv}	x	L	x	H	H	99h or 19h (Note 2)	x

Notes:

1. Sector unprotected code:00h. Sector protected code:01h.
2. Factory locked code: 99h. Factory unlocked code: 19h.
3. AM: MSB of address.

FUNCTIONAL OPERATION DESCRIPTION

READ OPERATION

To perform a read operation, the system addresses the desired memory array or status register location by providing its address on the address pins and simultaneously enabling the chip by driving CE# & OE# LOW, and WE# HIGH. After the Tce and Toa timing requirements have been met, the system can read the contents of the addressed location by reading the Data (I/O) pins. If either the CE# or OE# is held HIGH, the outputs will remain tri-stated and no data will appear on the output pins.

WRITE OPERATION

To perform a write operation, the system provides the desired address on the address pins, enables the chip by asserting CE# LOW, and disables the Data (I/O) pins by holding OE# HIGH. The system then places data to be written on the Data (I/O) pins and pulses WE# LOW. The device captures the address information on the falling edge of WE# and the data on the rising edge of WE#. To see an example, please refer to the timing diagram in [Figure 1](#). The system is not allowed to write invalid commands (commands not defined in this datasheet) to the device. Writing an invalid command may put the device in an undefined state.

DEVICE RESET

Driving the RESET# pin LOW for a period of Trp or more will return the device to Read mode. If the device is in the middle of a program or erase operation, the reset operation will take at most a period of Tready1 before the device returns to Read mode. Until the device does returns to Read mode, the RY/BY# pin will remain Low (Busy Status).

When the RESET# pin is held at GND±0.3V, the device only consumes standby (Isbr) current. However, the device draws larger current if the RESET# pin is held at a voltage greater than GND+0.3V and less than or equal to Vil.

It is recommended to tie the system reset signal to the RESET# pin of the flash memory. This allows the device to be reset with the system and puts it in a state where the system can immediately begin reading boot code from it.

STANDBY MODE

The device enters Standby mode whenever the RESET# and CE# pins are both held High. While in this mode, WE# and OE# will be ignored, all Data Output pins will be in a high impedance state, and the device will draw minimal (Isb) current.

OUTPUT DISABLE

While in active mode (RESET# HIGH and CE# LOW), the OE# pin controls the state of the output pins. If OE# is held HIGH, all Data (I/O) pins will remain tri-stated. If held LOW, the Byte or Word Data (I/O) pins will drive data.

FUNCTIONAL OPERATION DESCRIPTION (cont'd)**BYTE/WORD SELECTION**

The BYTE# input pin is used to select the organization of the array data and how the data is input/output on the Data (I/O) pins. If the BYTE# pin is held HIGH, Word mode will be selected and all 16 data lines (Q15 to Q0) will be active.

If BYTE# is forced LOW, Byte mode will be active and only data lines Q7 to Q0 will be active. Data lines Q8 to Q14 will remain in a high impedance state and Q15 becomes the A-1 address input pin.

HARDWARE WRITE PROTECT

By driving the WP#/ACC pin LOW, the outermost two boot sectors are protected from all erase/program operations. If WP#/ACC is held HIGH (Vih to VCC), these two outermost sectors revert to their previously protected/unprotected status.

ACCELERATED PROGRAMMING OPERATION

By applying high voltage (Vhv) to the WP#/ACC pin, the device will enter the Accelerated Programming mode. This mode permits the system to skip the normal command unlock sequences and program byte/word locations directly. During accelerated programming, the current drawn from the WP#/ACC pin is no more than Icp1.

TEMPORARY SECTOR GROUP UNPROTECT OPERATION

The system can apply Vhv to the RESET# pin to place the device in Temporary Unprotect mode. In this mode, previously protected sectors can be programmed/erased just as though they were unprotected. The device returns to normal operation once Vhv is removed from the RESET# pin and previously protected sectors will once again be protected.

SECTOR GROUP PROTECT OPERATION

The MX29LV320E T/B provides user programmable protection against program/erase operations for selected sectors. Most sectors cannot be protected individually. Instead, they are bound in groups of four or less called Sector-Groups. Protection is available for individual Sector-Groups, which includes all member sectors. Boot sectors are the exception to this rule as they are assigned unique Sector-Group addresses and can be protected individually without protecting any adjacent sectors or Sector-Groups. The three sectors adjacent to the boot sectors form a non-standard Sector-Group. Please refer to Table 1a and Table 1b which show all Sector-Group assignments.

During the protection operation, the sector address of any sector within a Sector-Group may be used to specify the Sector-Group being protected.

There are two methods available to protect Sector-Groups. The first and preferred method is activated by applying Vhv on the RESET# pin and following the timing in [Figure 13](#) and the algorithm shown in [Figure 14](#). This is a command operation that can be performed either on an external programmer or in-circuit by the system controller. The second method is strictly a bus operation and is entered by asserting Vhv on A9 and OE# pins, with A6 and CE# at Vil. The protection operation begins at the falling edge of WE# and terminates at the rising edge. Contact Macronix for more details on this method.

FUNCTIONAL OPERATION DESCRIPTION (cont'd)

CHIP UNPROTECT OPERATION

The Chip Unprotect operation unprotects all sectors within the device. It is standard procedure and highly recommended to protect all Sector-Groups prior using the Chip Unprotect operation. This will prevent possible damage to the Sector-Group protection logic. All Sector Groups are unprotected when shipped from the factory, so this operation is only necessary if the user has previously protected any Sector-Groups and wishes to unprotect them now.

MX29LV320E T/B provides two methods for unprotecting the entire chip. The first and preferred method is entered by applying V_hv on RESET# pin and following the timing diagram in [Figure 13](#) and using the algorithm shown in [Figure 15](#).

The second method is entered by asserting V_hv on A9 and OE# pins, with A6 at V_{ih} and CE# at V_{il}. The protection operation begins at the falling edge of WE# and terminates at the rising edge. Contact Macronix for more details on this method.

AUTOMATIC SELECT BUS OPERATIONS

The following five bus operations require A9 to be raised to V_hv. Please see AUTOMATIC SELECT COMMAND SEQUENCE in the COMMAND OPERATIONS section for details of equivalent command operations that do not require the use of V_hv.

SECTOR LOCK STATUS VERIFICATION

To determine the protected state of any sector using bus operations, the system performs a READ OPERATION with A9 raised to V_hv, the sector address applied to address pins A20 to A12, address pins A6 & A0 held LOW, and address pin A1 held HIGH. If data bit Q0 is LOW, the sector is not protected, and if Q0 is HIGH, the sector is protected.

READ SILICON ID MANUFACTURER CODE

To determine the Silicon ID Manufacturer Code, the system performs a READ OPERATION with A9 raised to V_hv and address pins A6, A1, & A0 held LOW. The Macronix ID code of C2h should be present on data bits Q7 to Q0.

READ SILICON ID MX29LV320ET CODE

To verify the Silicon ID MX29LV320ET Code, the system performs a READ OPERATION with A9 raised to V_hv, address pins A6 & A1 held LOW, and address pin A0 held HIGH. The MX29LV320ET code of A7h should be present on data bits Q7 to Q0. Q15 to Q8 will be tri-stated unless Word mode is selected. In this case, Q15 to Q8 will output the value 22h.

READ SILICON ID MX29LV320EB CODE

To verify the Silicon ID MX29LV320EB Code, the system performs a READ OPERATION with A9 raised to V_hv, address pins A6 & A1 held LOW, and address pin A0 held HIGH. The MX29LV320ET code of A8h should be present on data bits Q7 to Q0. Q15 to Q8 will be tri-stated unless Word mode is selected. In this case, Q15 to Q8 will output the code 22h.



FUNCTIONAL OPERATION DESCRIPTION (cont'd)

READ INDICATOR BIT (Q7) FOR SECURITY SECTOR

To determine if the Security Sector has been locked at the factory, the system performs a READ OPERATION with A9 raised to V_{hv}, address pin A6 held LOW, and address pins A1 & A0 held HIGH. If the Security Sector has been locked at the factory, the code 99h will be present on data bits Q7 to Q0. Otherwise, the factory unlocked code of 19h will be present.

INHERENT DATA PROTECTION

To avoid accidental erasure or programming of the device, the device is automatically reset to Read mode during power up. Additionally, the following design features protect the device from unintended data corruption.

COMMAND COMPLETION

Only after the successful completion of the specified command sets will the device begin its erase or program operation. If any command sequence is interrupted or given an invalid command, the device immediately returns to Read mode.

LOW VCC WRITE INHIBIT

The device refuses to accept any write command when V_{cc} is less than V_{Iko}. This prevents data from spuriously being altered during power-up, power-down, or temporary power interruptions. The device automatically resets itself when V_{cc} is lower than V_{Iko} and write cycles are ignored until V_{cc} is greater than V_{Iko}. The system must provide proper signals on control pins after V_{cc} rises above V_{Iko} to avoid unintentional program or erase operations.

WRITE PULSE "GLITCH" PROTECTION

CE#, WE#, OE# pulses shorter than 5ns are treated as glitches and will not be regarded as an effective write cycle.

LOGICAL INHIBIT

A valid write cycle requires both CE# and WE# at V_{il} with OE# at V_{ih}. Write cycle is ignored when either CE# at V_{ih}, WE# at V_{ih}, or OE# at V_{il}.

POWER-UP SEQUENCE

Upon power up, the MX29LV320E T/B is placed in Read mode. Furthermore, program or erase operation will begin only after successful completion of specified command sequences.



FUNCTIONAL OPERATION DESCRIPTION (cont'd)

POWER-UP WRITE INHIBIT

When WE#, CE# is held at V_{il} and OE# is held at V_{ih} during power up, the device ignores the first command on the rising edge of WE#.

POWER SUPPLY DECOUPLING

A 0.1 μ F capacitor should be connected between the Vcc and GND to reduce the noise effect.

COMMAND OPERATIONS

TABLE 3. MX29LV320E T/B COMMAND DEFINITIONS

Command		Read Mode	Reset Mode	Automatic Select								Enter Security Sector Region Enable	
				Manufacture ID		Device ID		Sector Factory		Sector Protect Verify		Word	Byte
				Word	Byte	Word	Byte	Word	Byte	Word	Byte		
1st Bus Cycle	Addr	Addr	XXX	555	AAA	555	AAA	555	AAA	555	AAA	555	AAA
	Data	Data	F0	AA	AA	AA	AA	AA	AA	AA	AA	AA	AA
2nd Bus Cycle	Addr			2AA	555	2AA	555	2AA	555	2AA	555	2AA	555
	Data			55	55	55	55	55	55	55	55	55	55
3rd Bus Cycle	Addr			555	AAA	555	AAA	555	AAA	555	AAA	555	AAA
	Data			90	90	90	90	90	90	90	90	88	88
4th Bus Cycle	Addr			X00	X00	X01	X02	X03	X06	(Sector) X02	(Sector) X04		
	Data			C2h	C2h	ID	ID	99/19	99/19	00/01	00/01		
5th Bus Cycle	Addr												
	Data												
6th Bus Cycle	Addr												
	Data												

Command		Exit Security Sector		Program		Chip Erase		Sector Erase		CFI Read		Erase Suspend	Erase Resume
		Word	Byte	Word	Byte	Word	Byte	Word	Byte	Word	Byte	Byte/Word	Byte/Word
1st Bus Cycle	Addr	555	AAA	555	AAA	555	AAA	555	AAA	55	AA	XXX	XXX
	Data	AA	AA	AA	AA	AA	AA	AA	AA	98	98	B0	30
2nd Bus Cycle	Addr	2AA	555	2AA	555	2AA	555	2AA	555				
	Data	55	55	55	55	55	55	55	55				
3rd Bus Cycle	Addr	555	AAA	555	AAA	555	AAA	555	AAA				
	Data	90	90	A0	A0	80	80	80	80				
4th Bus Cycle	Addr	XXX	XXX	Addr	Addr	555	AAA	555	AAA				
	Data	00	00	Data	Data	AA	AA	AA	AA				
5th Bus Cycle	Addr					2AA	555	2AA	555				
	Data					55	55	55	55				
6th Bus Cycle	Addr					555	AAA	Sector	Sector				
	Data					10	10	30	30				

Notes:

1. ID 22A7h(Top), 22A8h(Bottom).
2. It is not allowed to adopt any other code which is not in the above command definition table.

COMMAND OPERATIONS (cont'd)**AUTOMATIC PROGRAMMING OF THE MEMORY ARRAY**

The MX29LV320E T/B provides the user the ability to program the memory array in Byte mode or Word mode. As long as the users enters the correct cycle defined in the [Table 3](#) (including 2 unlock cycles and the A0H program command), any byte or word data provided on the data lines by the system will automatically be programmed into the array at the specified location.

After the program command sequence has been executed, the internal write state machine (WSM) automatically executes the algorithms and timings necessary for programming and verification, which includes generating suitable program pulses, checking cell threshold voltage margins, and repeating the program pulse if any cells do not pass verification or have low margins. The internal controller protects cells that do pass verification and margin tests from being over-programmed by inhibiting further program pulses to these passing cells as weaker cells continue to be programmed.

With the internal WSM automatically controlling the programming process, the user only needs to enter the program command and data once.

Programming will only change the bit status from "1" to "0". It is not possible to change the bit status from "0" to "1" by programming. This can only be done by an erase operation. Furthermore, the internal write verification only checks and detects errors in cases where a "1" is not successfully programmed to "0".

Any commands written to the device during programming will be ignored except hardware reset, which will terminate the program operation after a period of time no more than Tready1. When the embedded program algorithm is complete or the program operation is terminated by a hardware reset, the device will return to Read mode.

The typical chip program time at room temperature of the MX29LV320E T/B is less than 36 seconds.

After the embedded program operation has begun, the user can check for completion by reading the following bits in the status register:

Status	Q7*1	Q6*1	Q5	RY/BY# *2
In progress	Q7#	Toggling	0	0
Finished	Q7	Stop toggling	0	1
Exceed time limit	Q7#	Toggling	1	0

*1: When an attempt is made to program a protected sector, the program operation will abort thus preventing any data changes in the protected sector. Q7 will output complement data and Q6 will toggle (briefly 1us or less) before aborting and returning the device to Read mode.

*2: RY/BY# is an open drain output pin and should be connected to VCC through a high value pull-up resistor.

ERASING THE MEMORY ARRAY

There are two types of erase operations performed on the memory array -- Sector Erase and Chip Erase. In the Sector Erase operation, one or more selected sectors may be erased simultaneously. In the Chip Erase operation, the complete memory array is erased except for any protected sectors.

COMMAND OPERATIONS (cont'd)

CHIP ERASE

The Chip Erase operation is used to erase all the data within the memory array. All memory cells containing a "0" will be returned to the erased state of "1". This operation requires 6 write cycles to initiate the action. The first two cycles are "unlock" cycles, the third is a configuration cycle, the fourth and fifth are also "unlock" cycles, and the sixth cycle initiates the chip erase operation.

During the chip erase operation, no other software commands will be accepted, but if a hardware reset is received or the working voltage is too low, that chip erase will be terminated. After Chip Erase, the chip will automatically return to Read mode.

The system can determine the status of the embedded chip erase operation by the following methods:

Status	Q7	Q6	Q5	Q2	RY/BY# ^{*1}
In progress	0	Toggling	0	Toggling	0
Finished	1	Stop toggling	0	1	1
Exceed time limit	0	Toggling	1	Toggling	0

*1: RY/BY# is an open drain output pin and should be connected to VCC through a high value pull-up resistor.

SECTOR ERASE SUSPEND

After beginning a sector erase operation, Erase Suspend is the only valid command that may be issued. If the system issues an Erase Suspend command during the 50us time-out period following a Sector Erase command, the time-out period will terminate immediately and the device will enter Erase-Suspended Read mode. If the system issues an Erase Suspend command after the sector erase operation has already begun, the device will not enter Erase-Suspended Read mode until Tready1 time has elapsed. The system can determine if the device has entered the Erase-Suspended Read mode through Q6, Q7, and RY/BY#.

After the device has entered Erase-Suspended Read mode, the system can read or program any sector(s) except those being erased by the suspended erase operation. Reading any sector being erased or programmed will return the contents of the status register. Whenever a suspend command is issued, the user must issue a resume command and check Q6 toggle bit status, before issuing another erase command. The system can use the status register bits shown in the following table to determine the current state of the device:

Status	Q7	Q6	Q5	Q3	Q2	RY/BY#
Erase suspend read in erase suspended sector	1	No toggle	0	N/A	Toggle	1
Erase suspend read in non-erase suspended sector	Data	Data	Data	Data	Data	1
Erase suspend program in non-erase suspended sector	Q7#	Toggle	0	N/A	N/A	0

When the device has suspended erasing, the user can execute the command sets except sector erase and chip erase, such as read silicon ID, sector protect verify, program, CFI query and erase resume.

COMMAND OPERATIONS (cont'd)

READ MANUFACTURER ID OR DEVICE ID

The Manufacturer ID (identification) is a unique hexadecimal number assigned to each manufacturer by the JEDEC committee. Each company has its own manufacturer ID, which is different from the ID of all other companies. The number assigned to Macronix is C2h.

The Device ID is a unique hexadecimal number assigned by the manufacturer for each one of the flash devices made by that manufacturer.

The above two ID types are stored in a 16-bit register on the flash device -- eight bits for each ID. This register is normally read by the user or by the programming machine to identify the manufacturer and the specific device.

After entering Automatic Select mode, performing a read operation with A1 & A0 held LOW will cause the device to output the Manufacturer ID on the Data I/O (Q7 to Q0) pins. Performing a read operation with A1 LOW and A0 HIGH will cause the device to output the Device ID.

SECURITY SECTOR LOCK STATUS

After entering Automatic Select mode, the customer can check the lock status of the Security Sector by performing a read operations with A0 and A1 held HIGH. If the code 99h is read from data pins Q7 to Q0, the sector has been locked at the factory. If the code 19h is read, the sector has not been locked at the factory.

VERIFY SECTOR GROUP PROTECTION

After entering Automatic Select mode, performing a read operation with A1 held HIGH and A0 held LOW and the address of the sector to be checked applied to A20 to A12, data bit Q0 will indicate the protected status of the addressed sector. If Q0 is HIGH, the sector is protected. Conversely, if Q0 is LOW, the sector is unprotected.

SECURITY SECTOR FLASH MEMORY REGION

The Security Sector region is an extra OTP memory space of 256Bytes (128Words) in length. The Security Sector can be locked by the factory prior to shipping, or it can be locked by the customer later.

In factory-locked device, security sector region is protected when shipped from factory and the security silicon sector indicator bit, Q7 (at autoselect address 03h) is set to "1". In customer lockable device, security sector region is unprotected when shipped from factory and the security silicon indicator bit is set to "0".

FACTORY LOCKED: SECURITY SECTOR PROGRAMMED AND PROTECTED AT THE FACTORY

In a factory locked device, the Security Sector is permanently locked before shipping from the factory. The device will have a 16-byte (8-word) ESN in the security region. In bottom boot devices, the ESN occupies addresses 00000h to 0000Fh in byte mode or 00000h to 00007h in word mode. In top boot devices, the ESN occupies addresses 3F0000h to 3F000Fh in byte mode or 1F8000h to 1F8007h in word mode.

COMMAND OPERATIONS (cont'd)

CUSTOMER LOCKABLE: SECURITY SECTOR NOT PROGRAMMED OR PROTECTED AT THE FACTORY

When the security feature is not required, the Security Sector can provide an extra sector of memory.

Two methods are available for protecting the Security Sector. Note that once the Security Sector is protected, there is NO way to unprotect it and its contents can no longer be altered.

The first protection method requires writing the three-cycle Enter Security Region command followed by the use of the Sector-Group protect algorithm as illustrated in [Figure 14](#) with the following exception: the RESET# pin may be at either Vih or Vhv. Unlike normal Sector-Groups, which do require Vhv on the RESET# pin, the Security Sector may be permanently locked in-circuit without the use of high voltage.

The second protection method also uses the three-cycle Enter Security Region command, but uses bus operations that applies Vhv to the A9 and OE# pins with A6, CE#, and WE# held LOW and the SA address applied to A20 to A12. The protection operation begins at the falling edge of WE# and terminates at the rising edge. Contact Macronix for more details on using this method.

After the Security Sector is locked and verified, the system must write an Exit Security Sector Region command, go through a power cycle, or issue a hardware reset to return the device to read normal array mode.

ENTER AND EXIT SECURITY SECTOR

The device allows the user to access the extra 256-Byte sector identified as the Security Sector, which may contain a random, 128-bits electronic serial number (ESN), or it may contain user data.

To access the Security Sector, the user must issue a three-cycle "Enter Security Sector" command sequence. To exit the Security Sector and return to normal operation, the user issues the four-cycle "Exit Security Sector" command. Before issuing the "Exit Security Sector" command, please ensure the entering of security sector region.

COMMAND OPERATIONS (cont'd)

RESET OPERATION

In the following situations, executing reset command will reset device back to Read mode:

- Among erase command sequence (before the full command set is completed)
- Sector erase time-out period
- Erase fail (while Q5 is high)
- Among program command sequence (before the full command set is completed, erase-suspended program included)
- Program fail (while Q5 is high, and erase-suspended program fail is included)
- Read silicon ID mode
- Sector protect verify
- CFI mode

While device is at the status of program fail or erase fail (Q5 is high), user must issue reset command to reset device back to read array mode. While the device is in read silicon ID mode, sector protect verify or CFI mode, user must issue reset command to reset device back to read array mode.

When the device is in the progress of programming (not program fail) or erasing (not erase fail), device will ignore reset command.

COMMON FLASH MEMORY INTERFACE (CFI) MODE

QUERY COMMAND AND COMMAND FLASH MEMORY INTERFACE (CFI) MODE

MX29LV320E T/B features CFI mode. Host system can retrieve the operating characteristics, structure and vendor-specified information such as identifying information, memory size, byte/word configuration, operating voltages and timing information of this device by CFI mode. The device enters the CFI Query mode when the system writes the CFI Query command, 98H, to address 55h/AAh (depending on Word/Byte mode) any time the device is ready to read array data. The system can read CFI information at the addresses given in Table 4.

Once user enters CFI query mode, user can not issue any other commands except reset command. The reset command is required to exit CFI mode and go back to the mode before entering CFI. The system can write the CFI Query command only when the device is in read mode, erase suspend, standby mode or automatic select mode. The CFI unused area is Macronix's reserved.

7DE0H8F1ERGH1GHQWLFDWLRQDWD9DOXHV
(All values in these tables are in hexadecimal)

Description	Address (h) (Word Mode)	Address (h) (Byte Mode)	Data (h)
Query-unique ASCII string "QRY"	10	20	0051
	11	22	0052
	12	24	0059
Primary vendor command set and control interface ID code	13	26	0002
	14	28	0000
Address for primary algorithm extended query table	15	2A	0040
	16	2C	0000
Alternate vendor command set and control interface ID code	17	2E	0000
	18	30	0000
Address for alternate algorithm extended query table	19	32	0000
	1A	34	0000

Table 4-2. CFI Mode: System Interface Data Values

Description	Address (h) (Word Mode)	Address (h) (Byte Mode)	Data (h)
Vcc supply minimum program/erase voltage	1B	36	0027
Vcc supply maximum program/erase voltage	1C	38	0036
VPP supply minimum program/erase voltage	1D	3A	0000
VPP supply maximum program/erase voltage	1E	3C	0000
Typical timeout per single word/byte write, 2 ⁿ us	1F	3E	0004
Typical timeout for maximum-size buffer write, 2 ⁿ us	20	40	0000
Typical timeout per individual block erase, 2 ⁿ ms	21	42	000A
Typical timeout for full chip erase, 2 ⁿ ms	22	44	0000
Maximum timeout for word/byte write, 2 ⁿ times typical	23	46	0005
Maximum timeout for buffer write, 2 ⁿ times typical	24	48	0000
Maximum timeout per individual block erase, 2 ⁿ times typical	25	4A	0004
Maximum timeout for chip erase, 2 ⁿ times typical	26	4C	0000

Table 4-3. CFI Mode: Device Geometry Data Values

Description	Address (h) (Word Mode)	Address (h) (Byte Mode)	Data (h)
Device size = 2 ⁿ in number of bytes	27	4E	0016
Flash device interface description (02=asynchronous x8/x16)	28	50	0002
	29	52	0000
Maximum number of bytes in buffer write = 2 ⁿ (not support)	2A	54	0000
	2B	56	0000
Number of erase regions within device	2C	58	0002
Index for Erase Bank Area 1 [2E,2D] = # of same-size sectors in region 1-1 [30, 2F] = sector size in multiples of 256-bytes	2D	5A	0007
	2E	5C	0000
	2F	5E	0020
	30	60	0000
Index for Erase Bank Area 2	31	62	003E
	32	64	0000
	33	66	0000
	34	68	0001
Index for Erase Bank Area 3	35	6A	0000
	36	6C	0000
	37	6E	0000
	38	70	0000
Index for Erase Bank Area 4	39	72	0000
	3A	74	0000
	3B	76	0000
	3C	78	0000

ELECTRICAL CHARACTERISTICS**ABSOLUTE MAXIMUM STRESS RATINGS**

Surrounding Temperature with Bias		-65°C to +125°C
Storage Temperature		-65°C to +150°C
Voltage Range	VCC	-0.5V to +4.0 V
	RESET#, A9 and OE#	-0.5V to +10.5 V
	The other pins	-0.5V to Vcc +0.5V
Output Short Circuit Current (less than one second)		200 mA

Note:

1. Minimum voltage may undershoot to -2V during transition and for less than 20ns during transitions.
2. Maximum voltage may overshoot to Vcc+2V during transition and for less than 20ns during transitions.

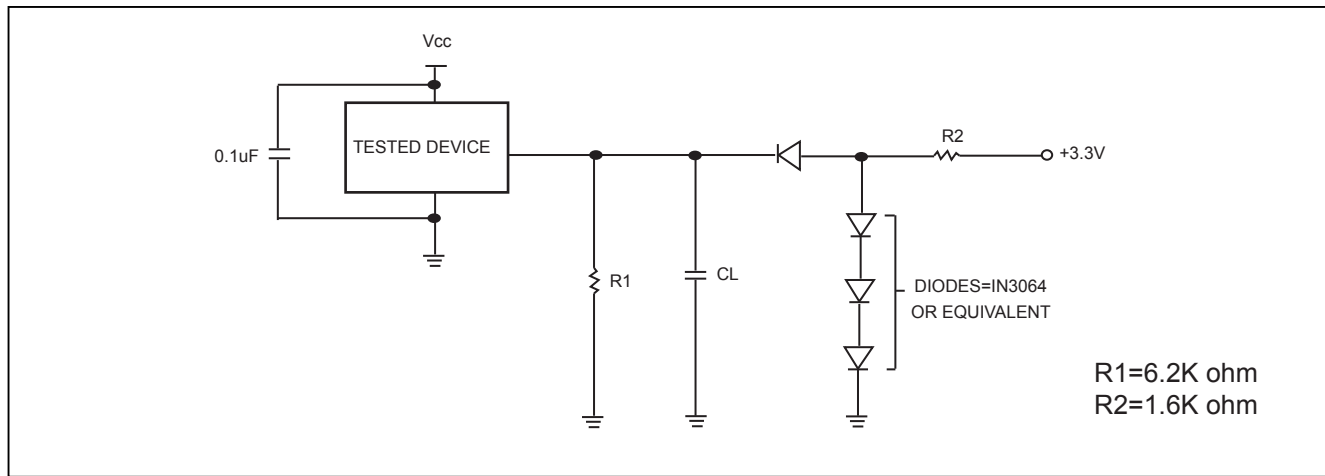
OPERATING TEMPERATURE AND VOLTAGE

Industrial (I) Grade	Surrounding Temperature (TA)	-40°C to +85°C
VCC Supply Voltages	VCC range	+2.7 V to 3.6 V

DC CHARACTERISTICS

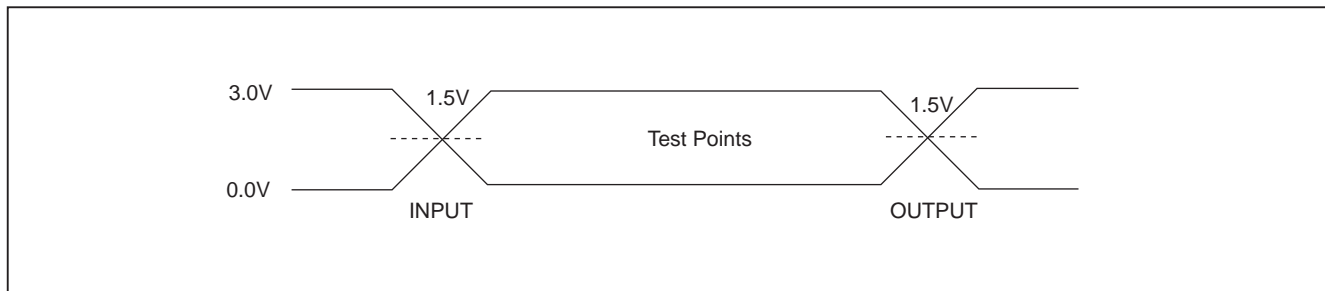
Symbol	Description	Min.	Typ.	Max.	Remark
Iilk	Input Leak			± 1.0uA	
Iilk9	A9 Leak			35uA(0~70°C)/ 45uA(-40~85°C)	A9=10.5V
Iolk	Output Leak			± 1.0uA	
Icr1	Read Current(5MHz)		10mA	16mA	CE#=Vil, OE#=Vih
Icr2	Read Current(1MHz)		2mA	4mA	CE#=Vil, OE#=Vih
Icw	Write Current		15mA	30mA	CE#=Vil, OE#=Vih,
I _{sb}	Standby Current		5uA	15uA	V _{cc} =V _{cc} max, other pin disable
I _{sr}	Reset Current		5uA	15uA	V _{cc} =V _{cc} max, Reset# enable, other pin disable
I _{sb} s	Sleep Mode Current		5uA	15uA	
I _{cp} 1	Accelerated Pgm Current, WP#/Acc pin (Word/Byte)		5mA	10mA	CE#=Vil, OE#=Vih
I _{cp} 2	Accelerated Pgm Current, Vcc pin, (Word/Byte)		15mA	30mA	CE#=Vil, OE#=Vih
V _{il}	Input Low Voltage	-0.5V		0.8V	
V _{ih}	Input High Voltage	0.7xV _{cc}		V _{cc} +0.3V	
V _{hv}	Very High Voltage for hardware Protect/Unprotect/Accelerated Program/Auto Select/Temporary Unprotect	9.5V		10.5V	
V _{ol}	Output Low Voltage			0.45V	I _{ol} =4.0mA
V _{oh} 1	Output High Voltage	0.85xV _{cc}			I _{oh} 1=-2mA
V _{oh} 2	Output High Voltage	V _{cc} -0.4V			I _{oh} 2=-100uA
V _{lko}	Low Vcc Lock-out Voltage	2.3V		2.5V	

SWITCHING TEST CIRCUIT



Test Condition
 Output Load : 1 TTL gate
 Output Load Capacitance,CL : 30pF
 Rise/Fall Times : 5ns
 In/Out reference levels :1.5V

SWITCHING TEST WAVEFORM



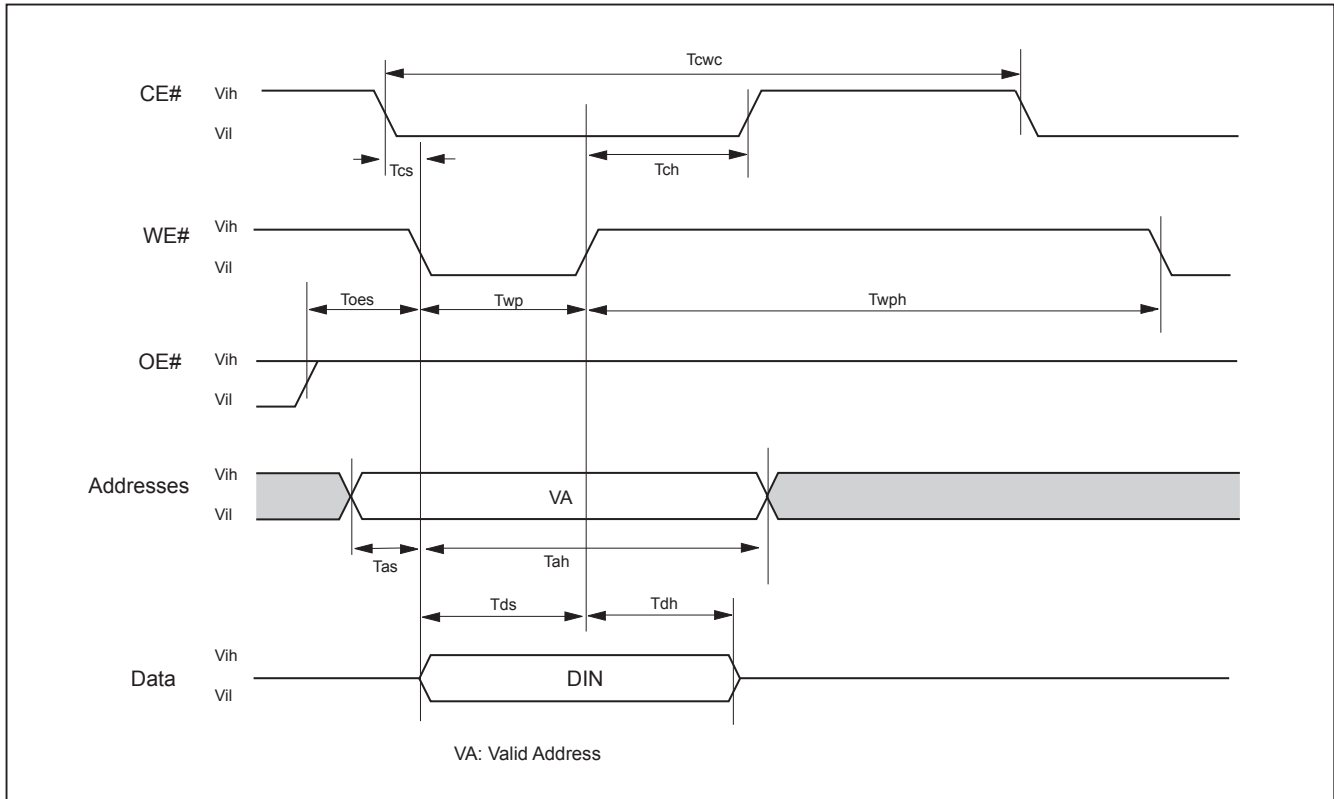
AC CHARACTERISTICS

Symbol	Description	Min.	Typ.	Max.	Unit	
Taa	Valid data output after address			70	ns	
Tce	Valid data output after CE# low			70	ns	
Toe	Valid data output after OE# low			30	ns	
Tdf	Data output floating after OE# high			30	ns	
Toh	Output hold time from the earliest rising edge of address, CE#, OE#	0			ns	
Trc	Read period time	70			ns	
Tsrw	Latency Between Read and Write Operation (*Note 1)	45			ns	
Twc	Write period time	70			ns	
Tcwc	Command write period time	70			ns	
Tas	Address setup time	0			ns	
Tah	Address hold time	45			ns	
Tds	Data setup time	45			ns	
Tdh	Data hold time	0			ns	
Tvcs	Vcc setup time	200			us	
Tcs	Chip enable Setup time	0			ns	
Tch	Chip enable hold time	0			ns	
Toes	Output enable setup time	0			ns	
Toeh	Output enable hold time	Read	0		ns	
		Toggle & Data# Polling	10		ns	
Tws	WE# setup time	0			ns	
Twh	WE# hold time	0			ns	
Tcep	CE# pulse width	45			ns	
Tceph	CE# pulse width high	30			ns	
Twp	WE# pulse width	35			ns	
Twph	WE# pulse width high	30			ns	
Tbusy	Program/Erase active time by RY/BY#			90	ns	
Tghwl	Read recover time before write	0			ns	
Tghel	Read recover time before write	0			ns	
Twhwh1	Program operation	Byte		9	300	us
		Word		11	360	us
Twhwh1	Acc program operation (Word/Byte)		7	210	us	
Twhwh2	Sector erase operation		0.7	2	sec	
Tbal	Sector add hold time		35	50	us	

* Note 1: Sampled only, not 100% tested.

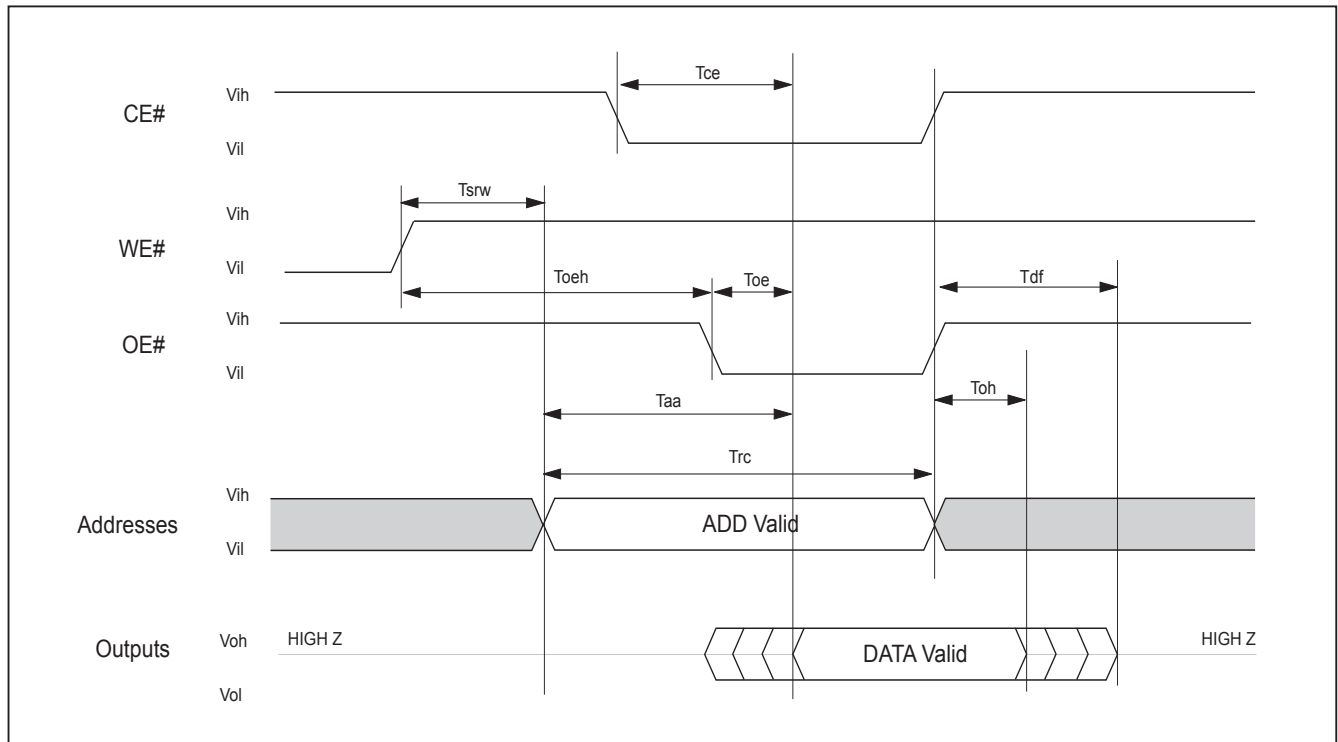
WRITE COMMAND OPERATION

Figure 1. COMMAND WRITE OPERATION



READ/RESET OPERATION

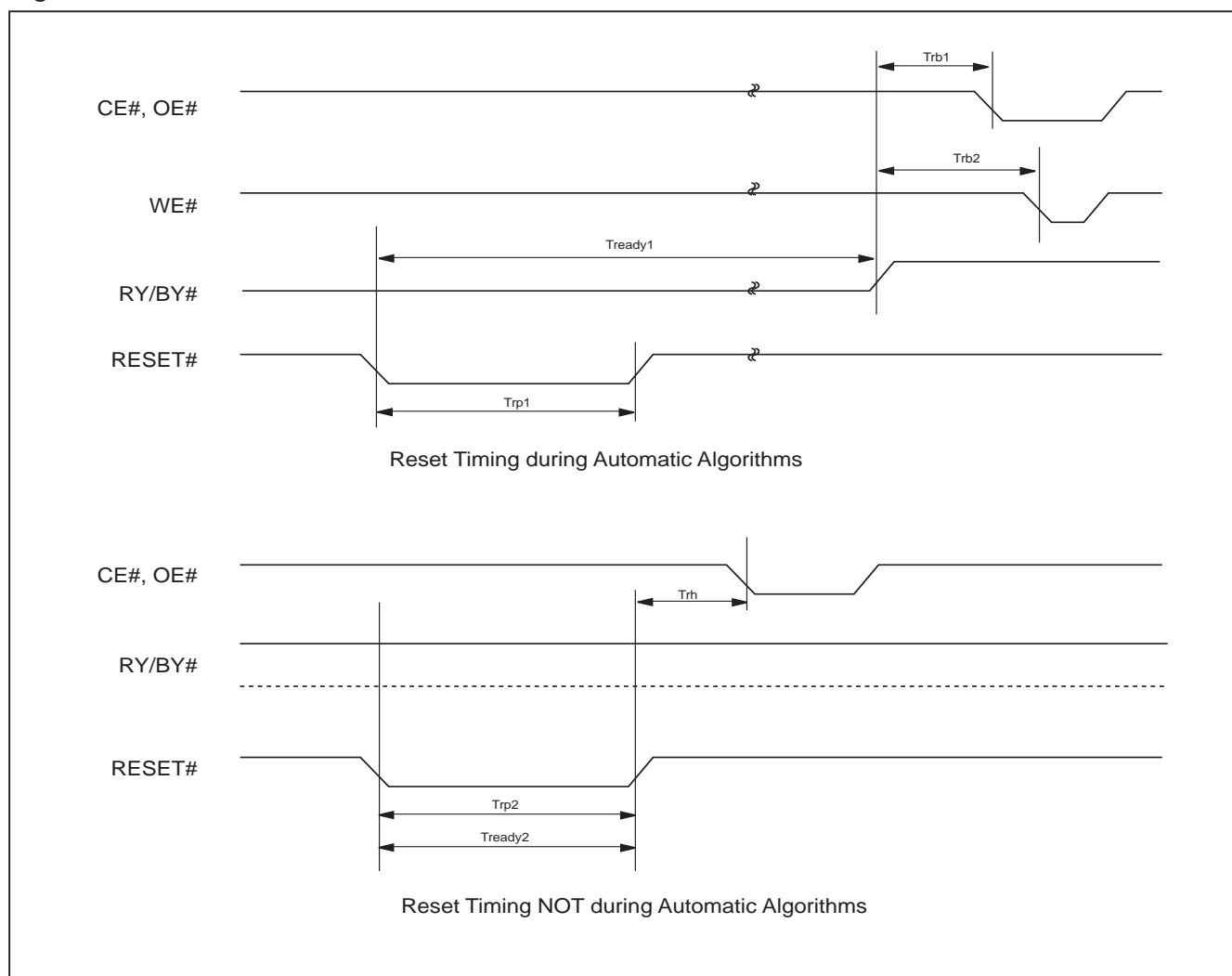
Figure 2. READ TIMING WAVEFORM



AC CHARACTERISTICS

Item	Description	Setup	Speed	Unit
Trp1	RESET# Pulse Width (During Automatic Algorithms)	MIN	10	us
Trp2	RESET# Pulse Width (NOT During Automatic Algorithms)	MIN	500	ns
Trh	RESET# High Time Before Read	MIN	70	ns
Trb1	RY/BY# Recovery Time (to CE#, OE# go low)	MIN	0	ns
Trb2	RY/BY# Recovery Time (to WE# go low)	MIN	50	ns
Tready1	RESET# PIN Low (During Automatic Algorithms) to Read or Write	MAX	20	us
Tready2	RESET# PIN Low (NOT During Automatic Algorithms) to Read or Write	MAX	500	ns

Figure 3. RESET# TIMING WAVEFORM



ERASE/PROGRAM OPERATION

Figure 4. AUTOMATIC CHIP ERASE TIMING WAVEFORM

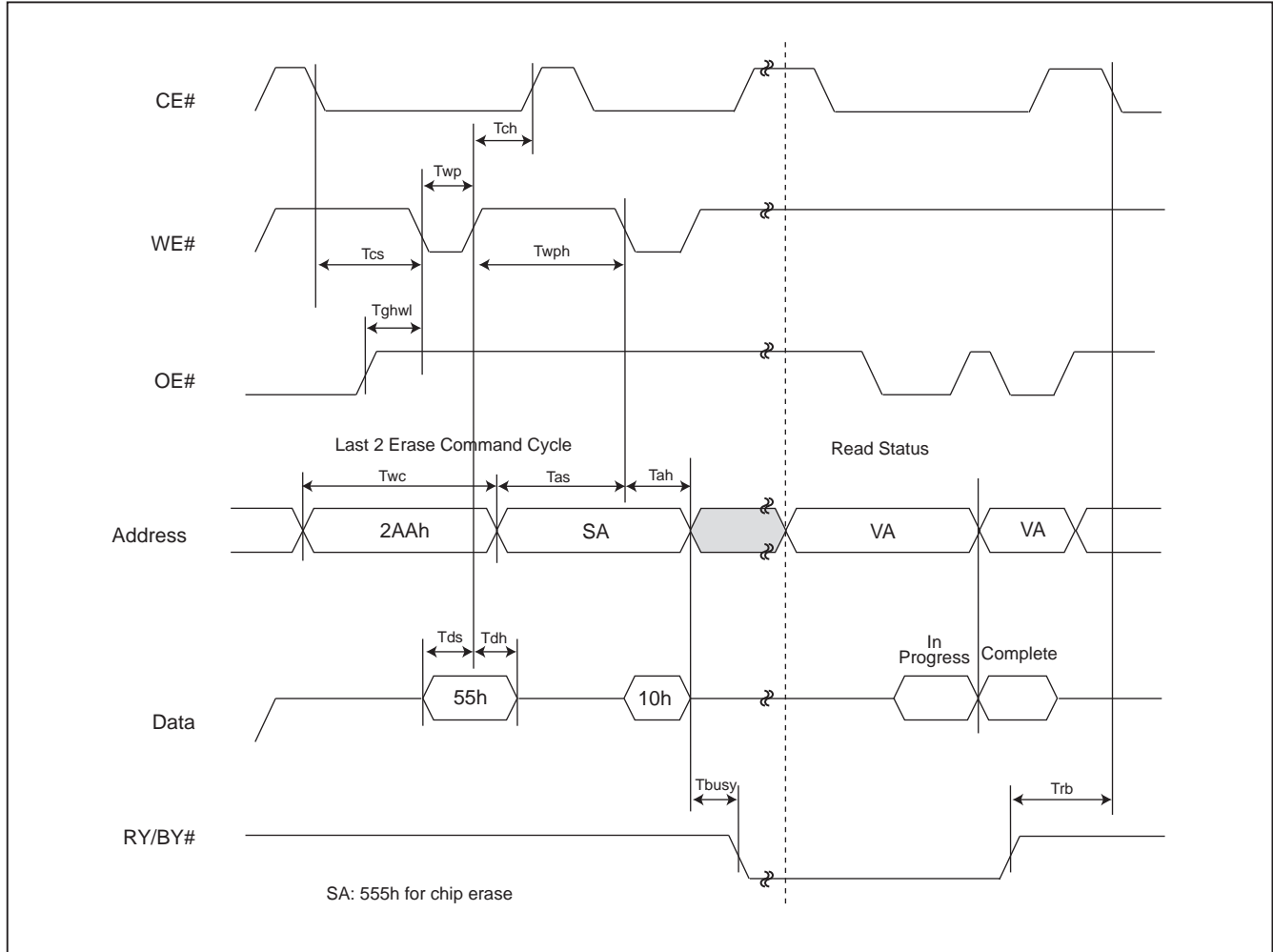


Figure 5. AUTOMATIC CHIP ERASE ALGORITHM FLOWCHART

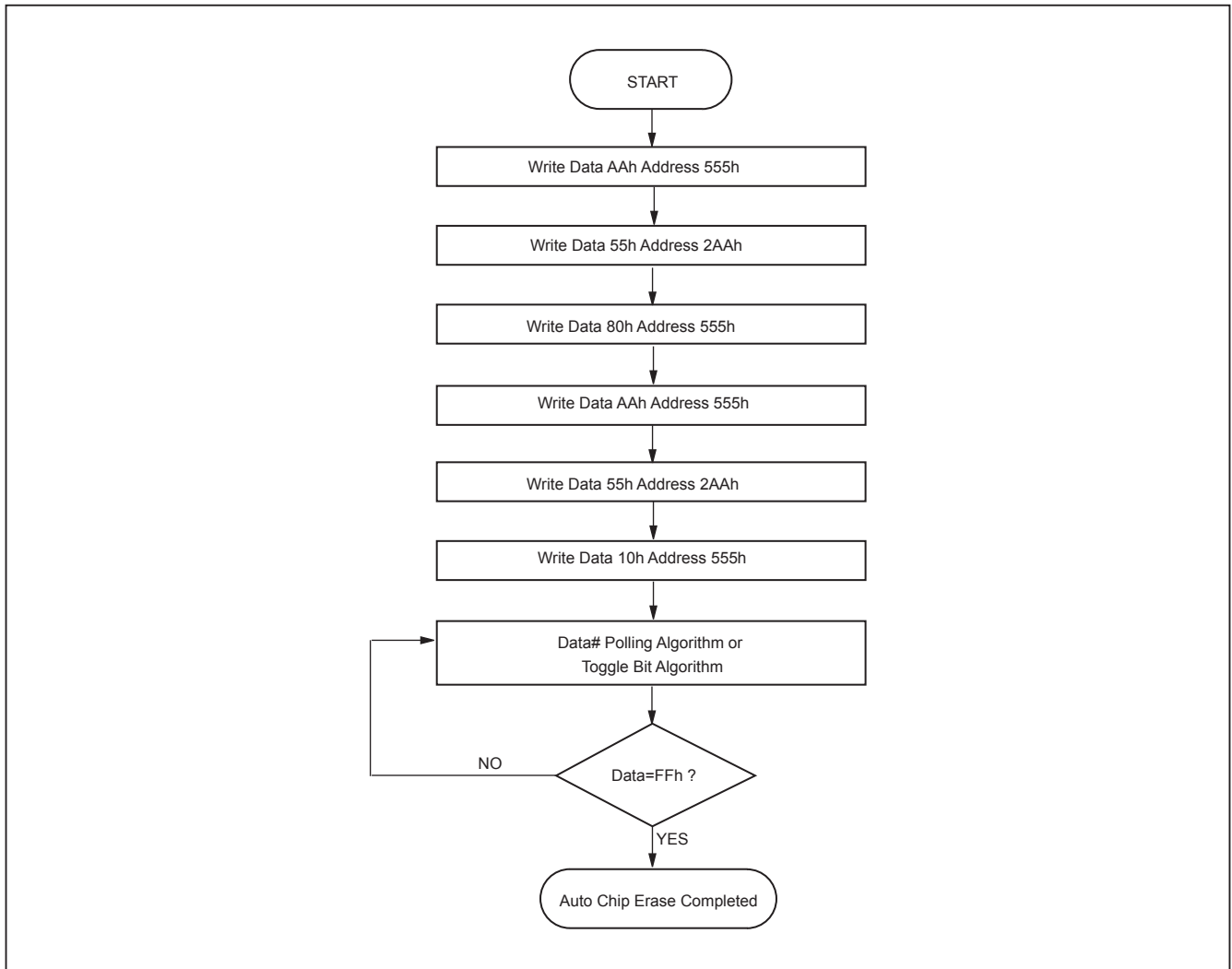


Figure 6. AUTOMATIC SECTOR ERASE TIMING WAVEFORM

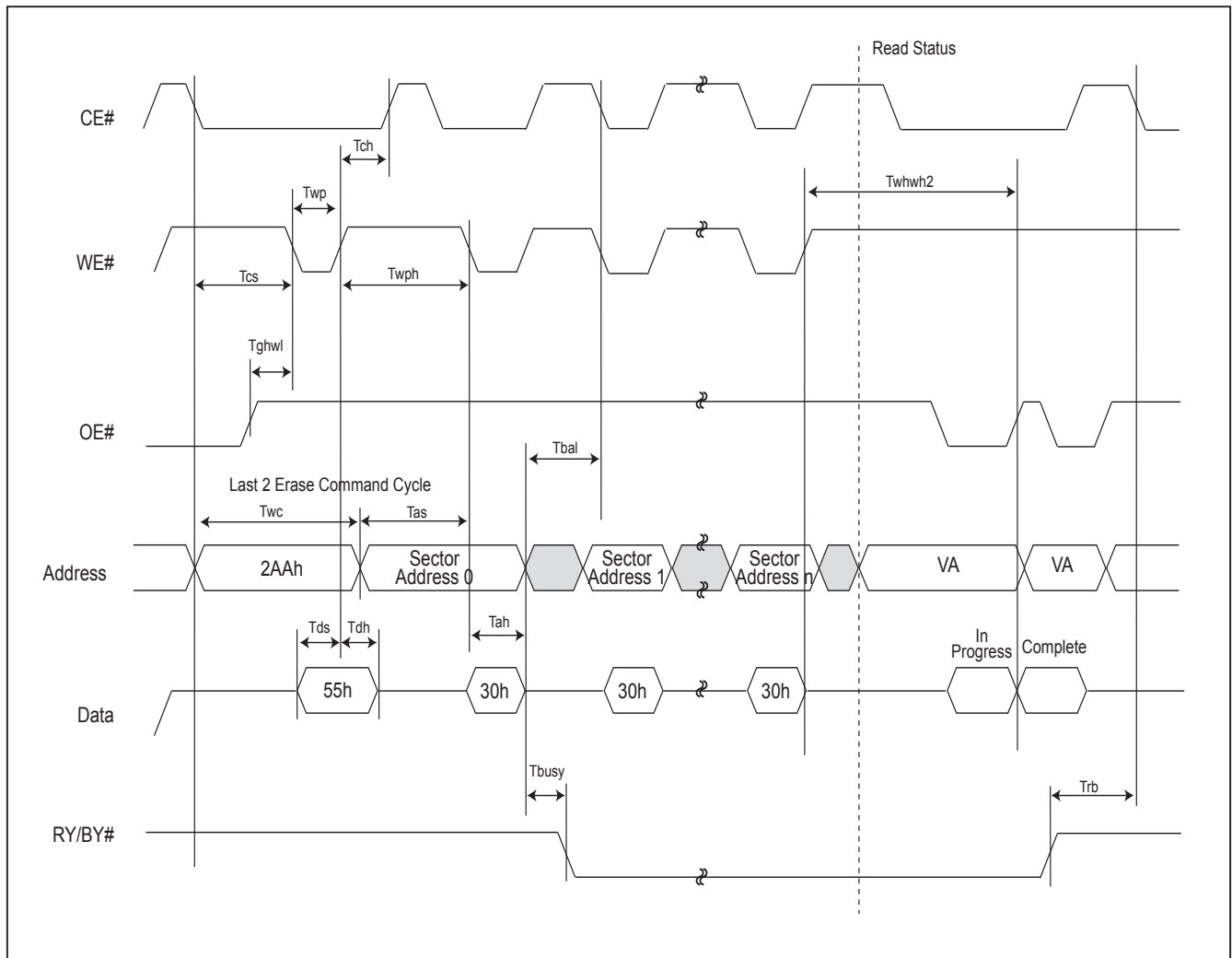


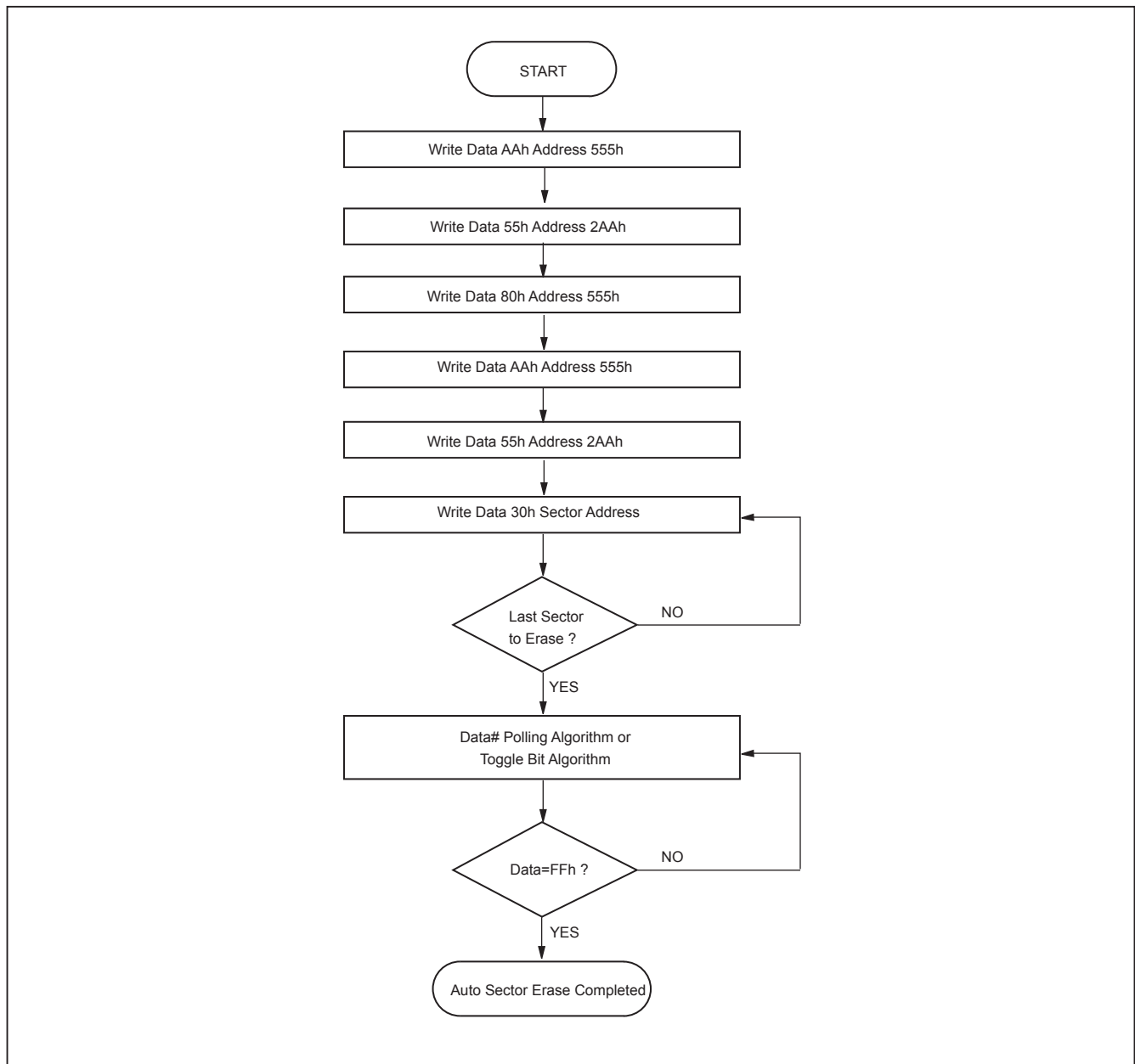
Figure 7. AUTOMATIC SECTOR ERASE ALGORITHM FLOWCHART

Figure 8. ERASE SUSPEND/RESUME FLOWCHART

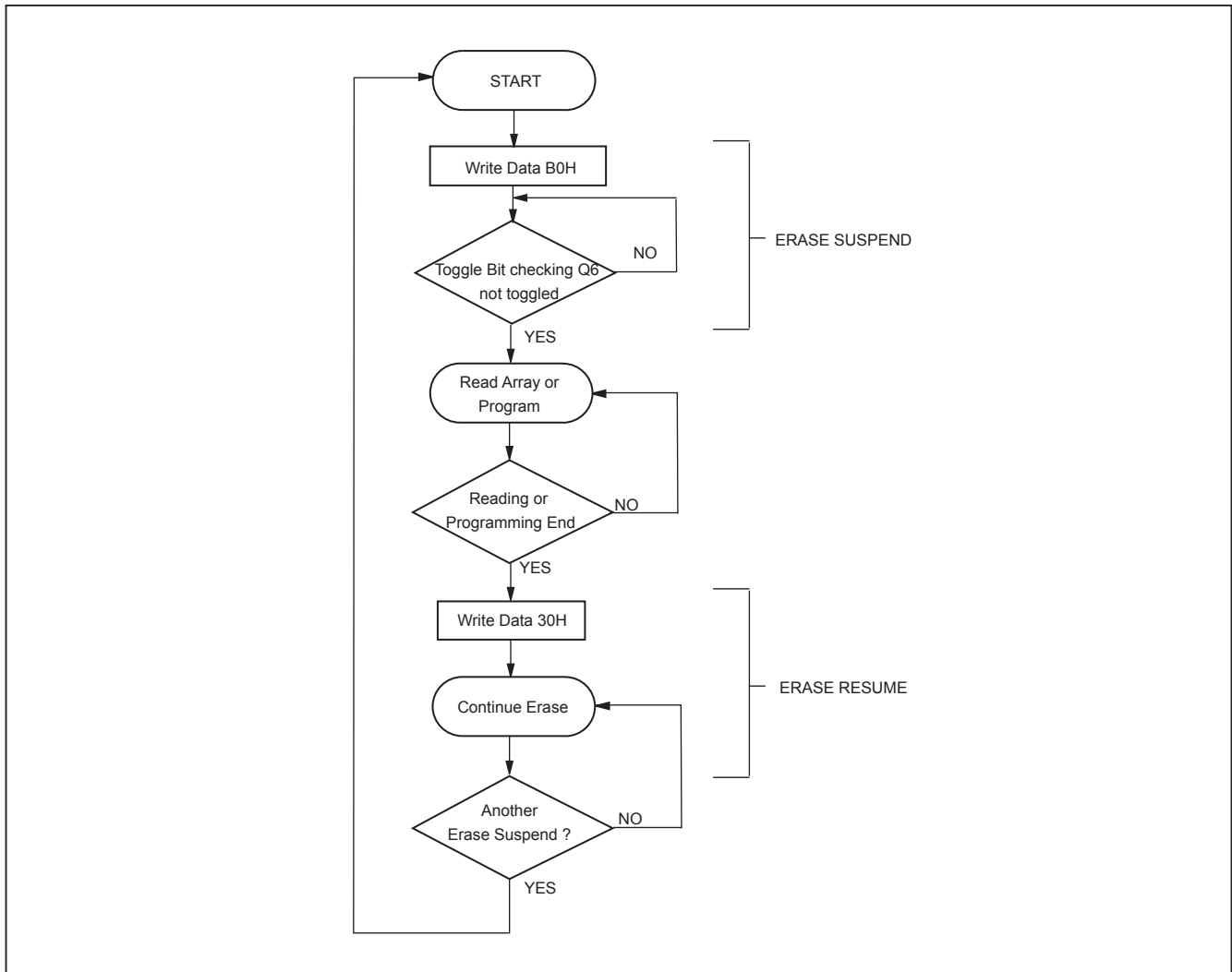


Figure 9. AUTOMATIC PROGRAM TIMING WAVEFORM

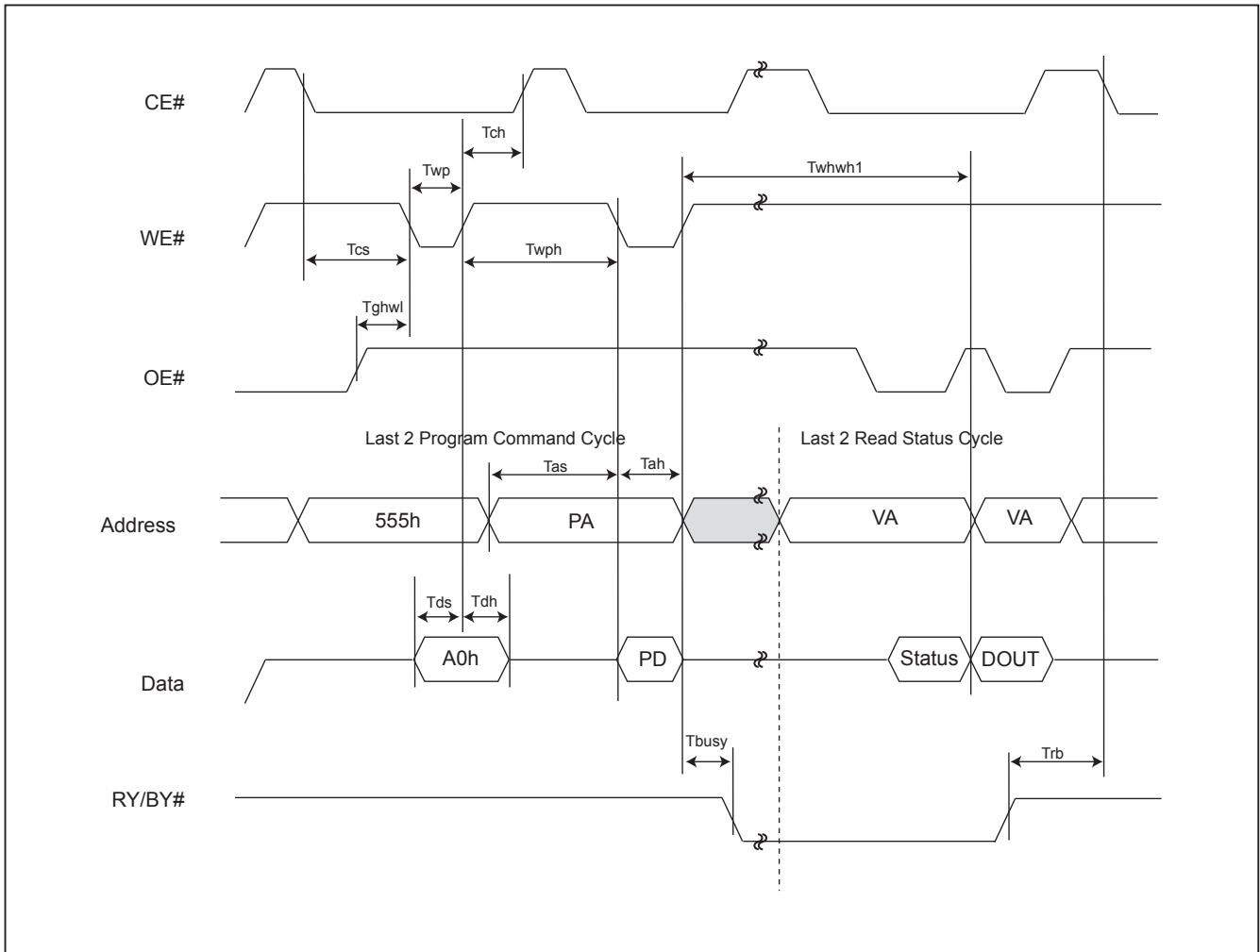


Figure 10. ACCELERATED PROGRAM TIMING DIAGRAM

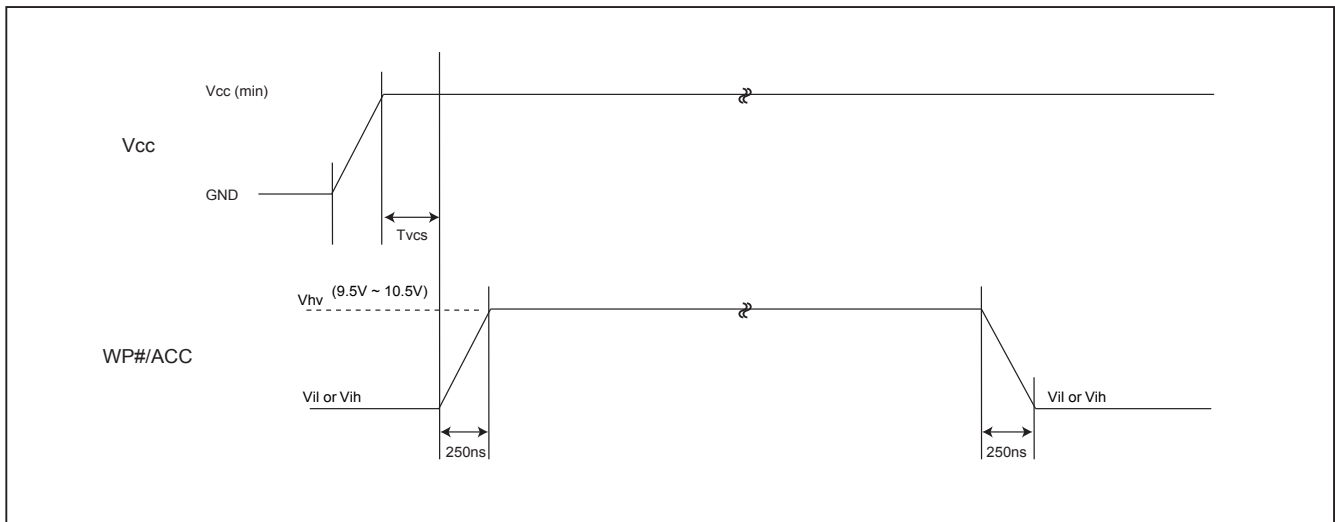


Figure 11. CE# CONTROLLED WRITE TIMING WAVEFORM

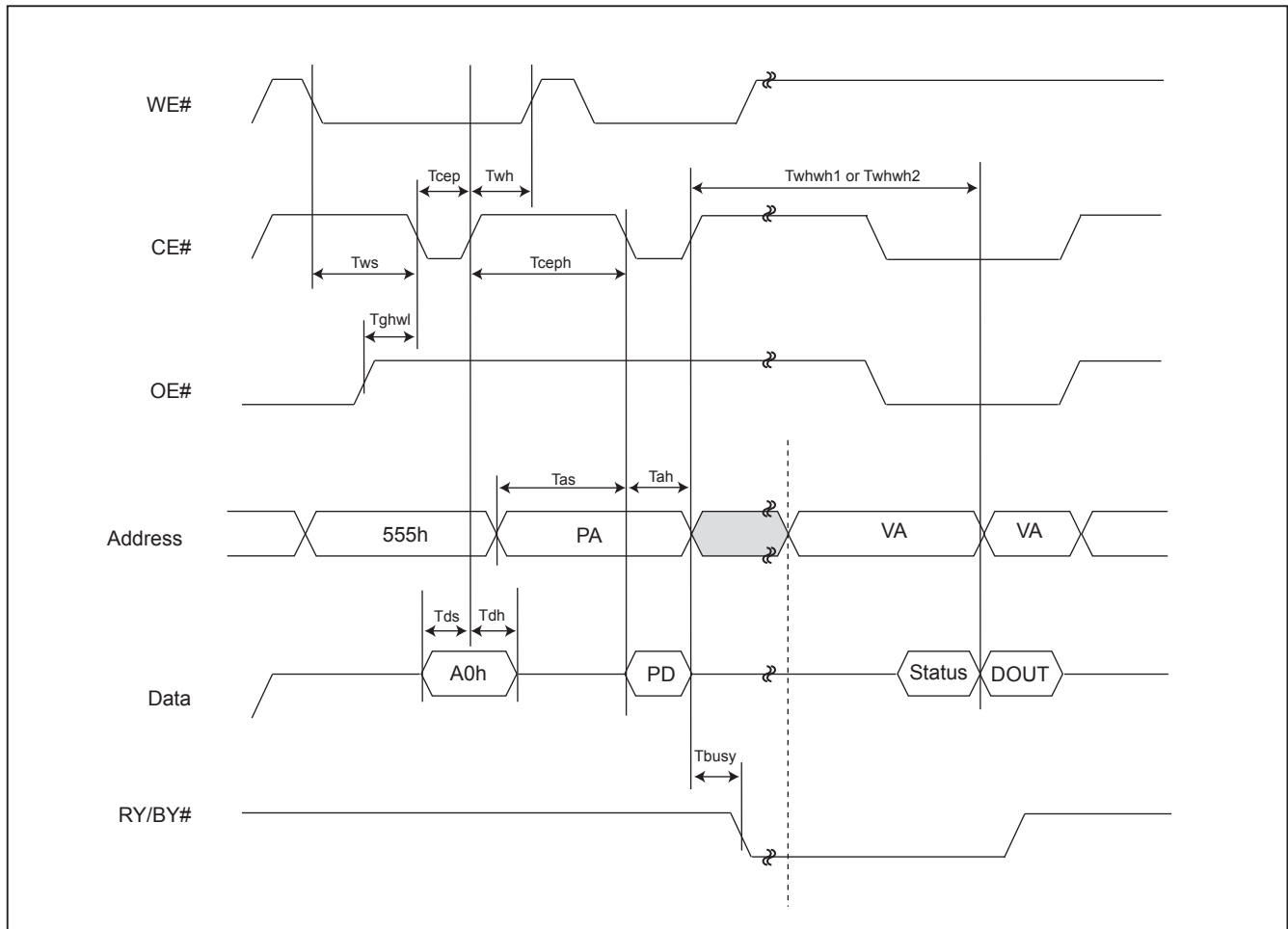
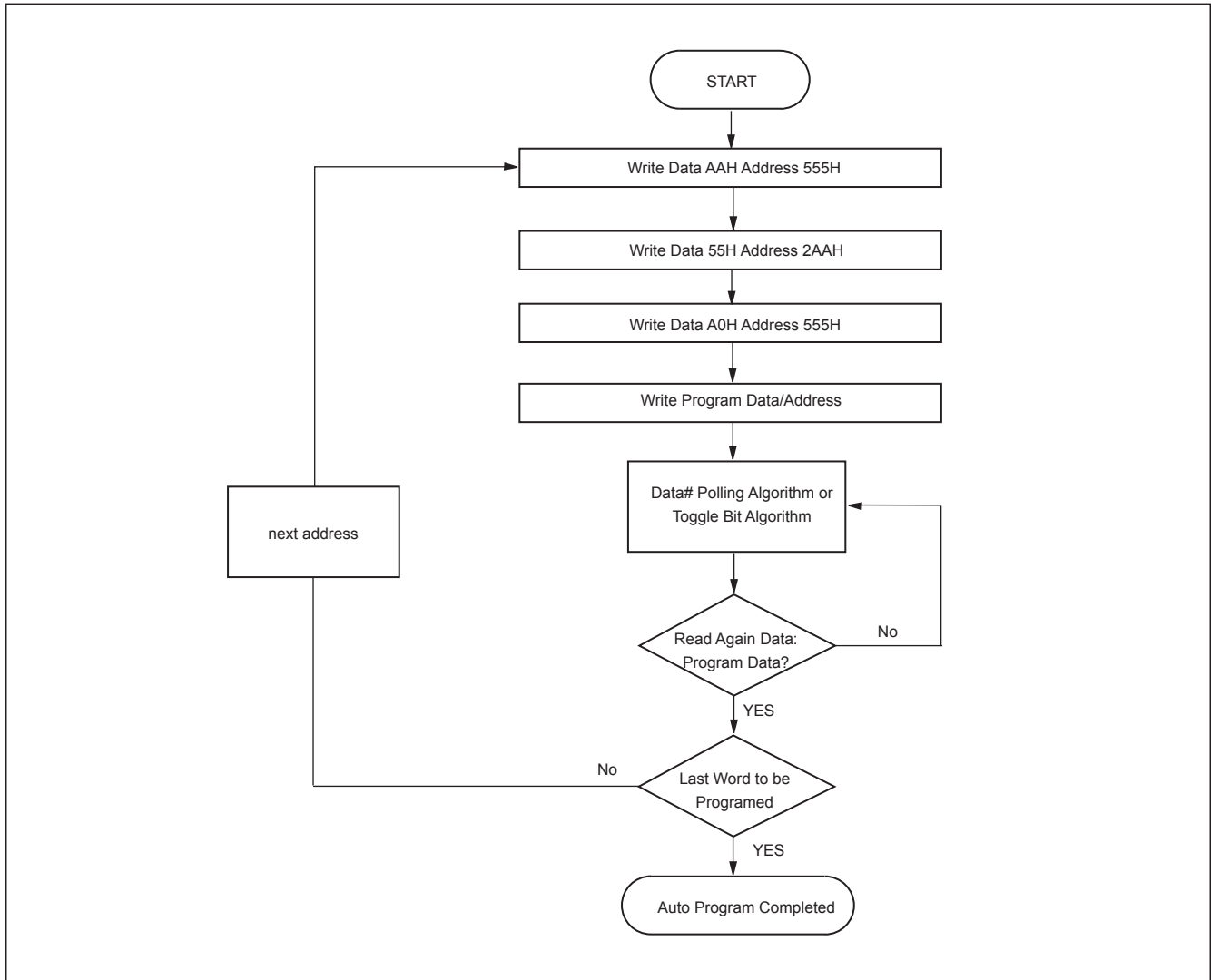


Figure 12. AUTOMATIC PROGRAMMING ALGORITHM FLOWCHART



SECTOR GROUP PROTECT/CHIP UNPROTECT

Figure 13. SECTOR GROUP PROTECT/CHIP UNPROTECT WAVEFORM (RESET# Control)

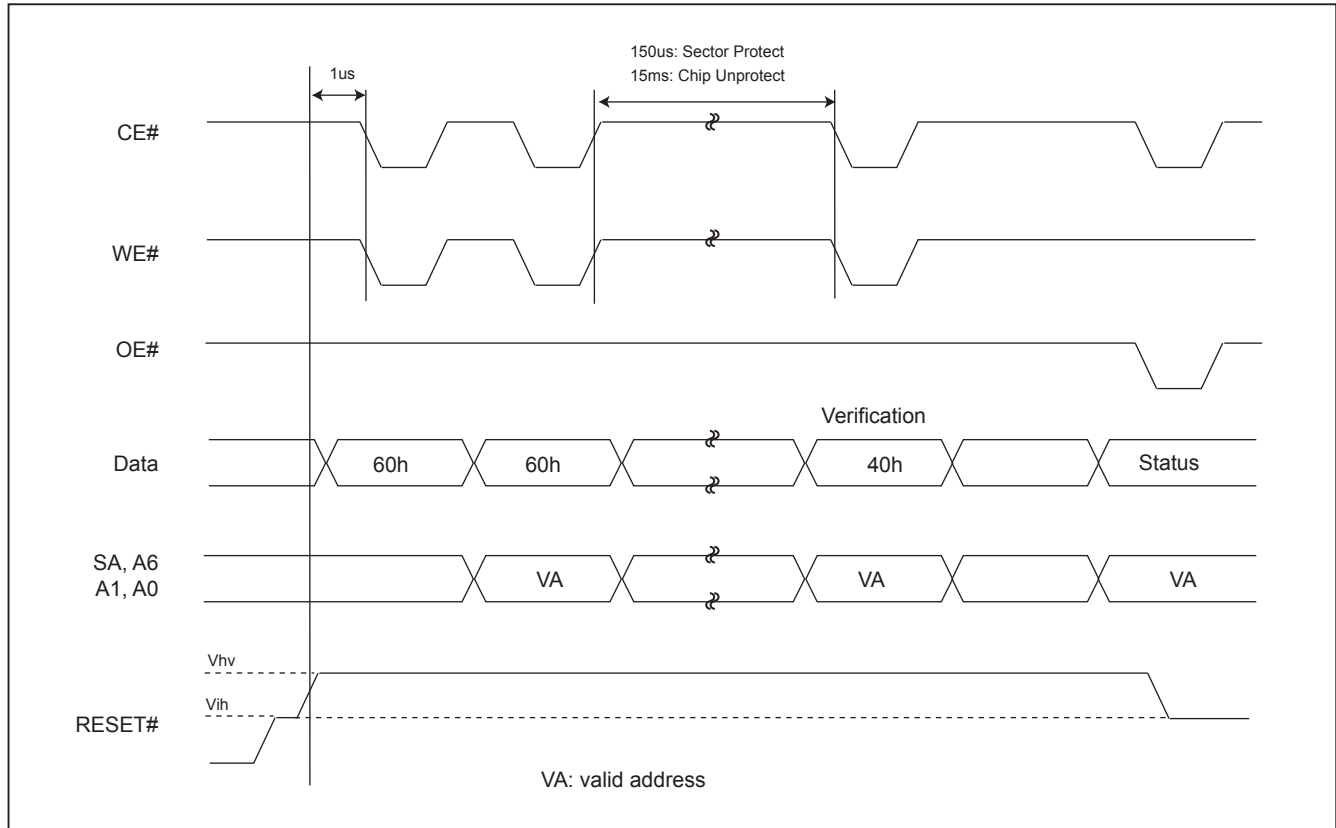


Figure 14. IN-SYSTEM SECTOR GROUP PROTECT WITH RESET#=Vhv

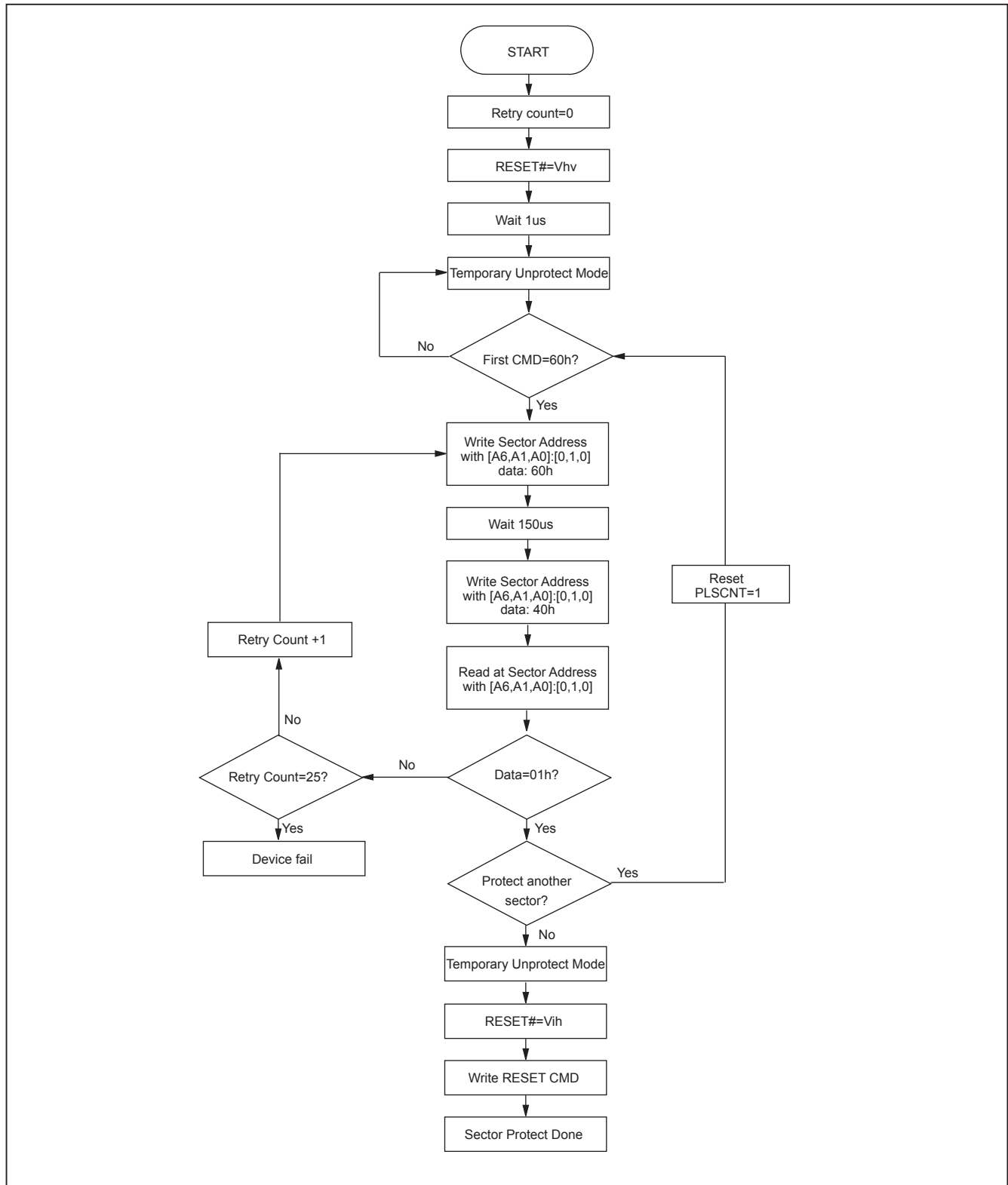


Figure 15. CHIP UNPROTECT ALGORITHM WITH RESET#=Vhv

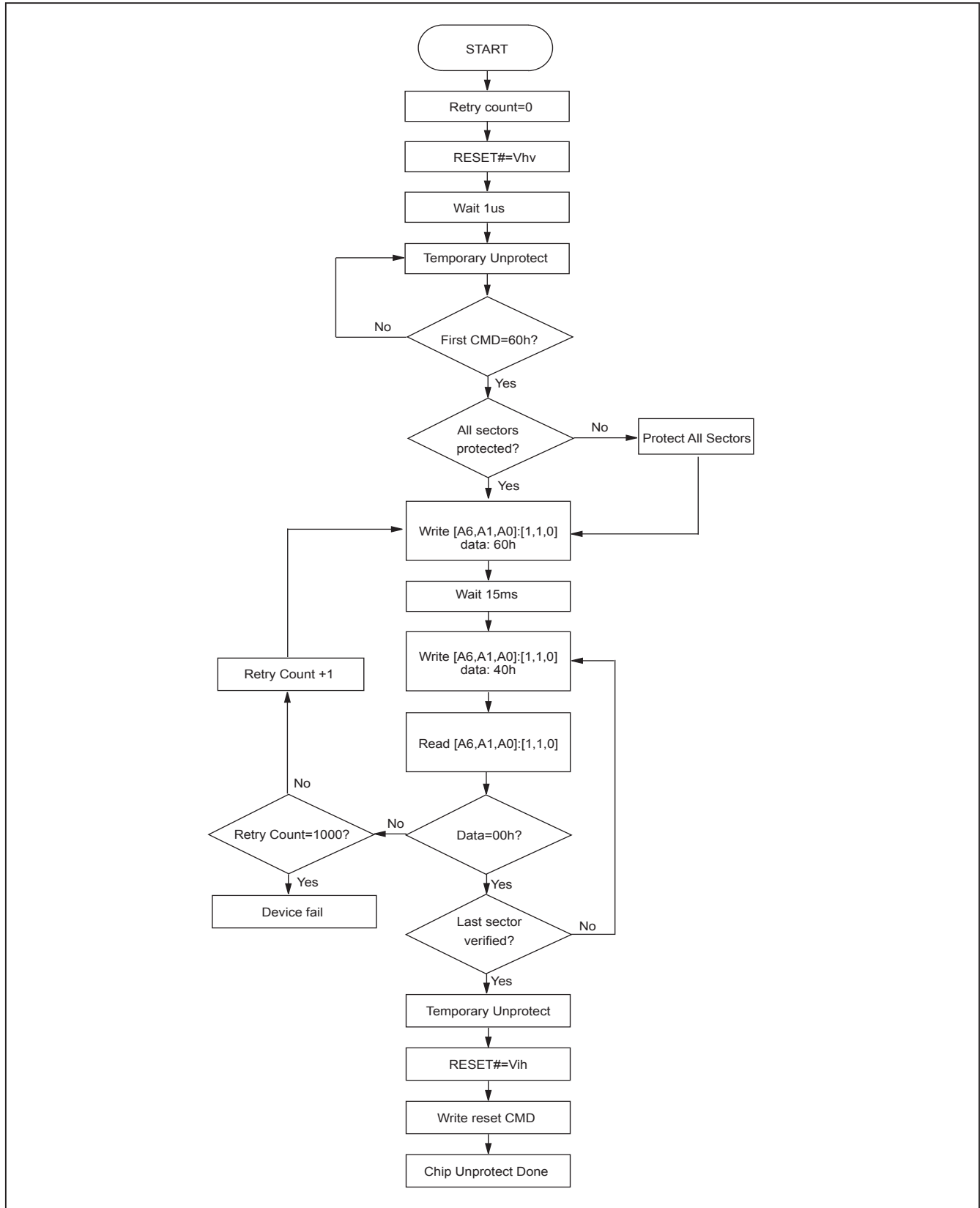


Table 5. TEMPORARY SECTOR GROUP UNPROTECT

Parameter	Alt	Description	Condition	Speed	Unit
Trpvhh	Tvidr	RESET# Rise Time to Vhv and Vhv Fall Time to RESET#	MIN	500	ns
Tvhhl	Trsp	RESET# Vhv to WE# Low	MIN	4	us

Figure 16. TEMPORARY SECTOR GROUP UNPROTECT WAVEFORM

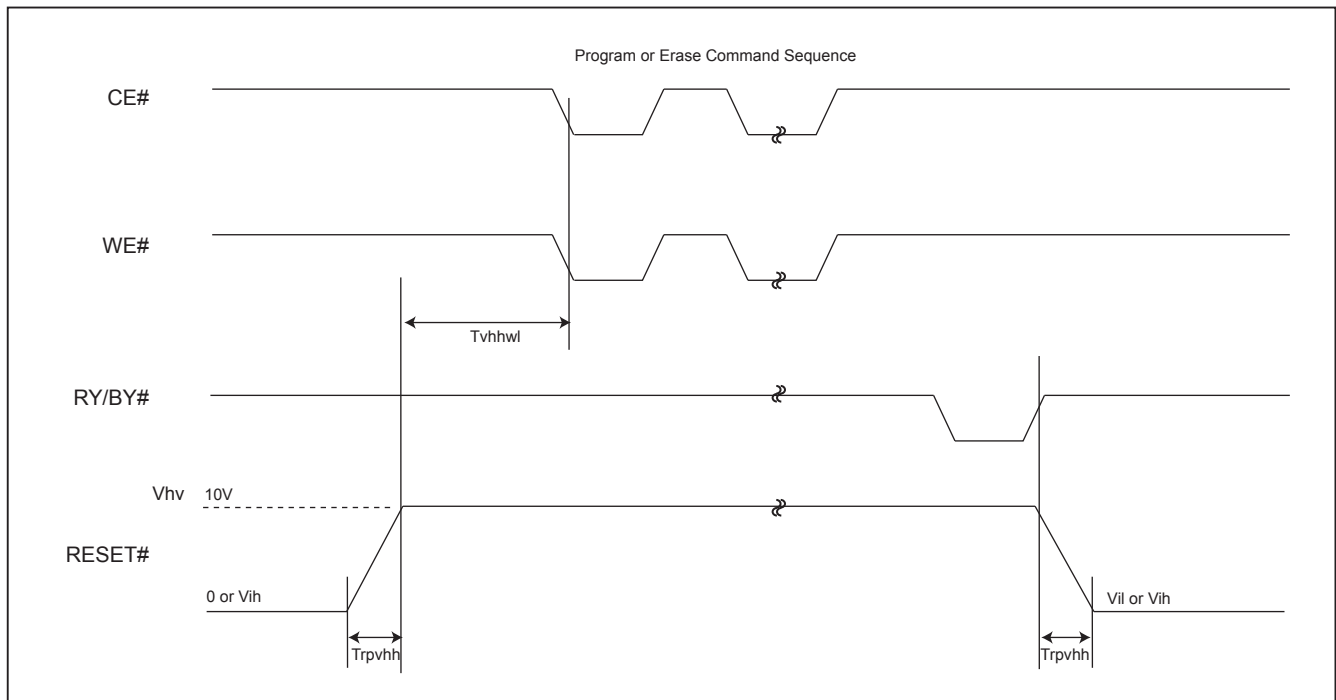
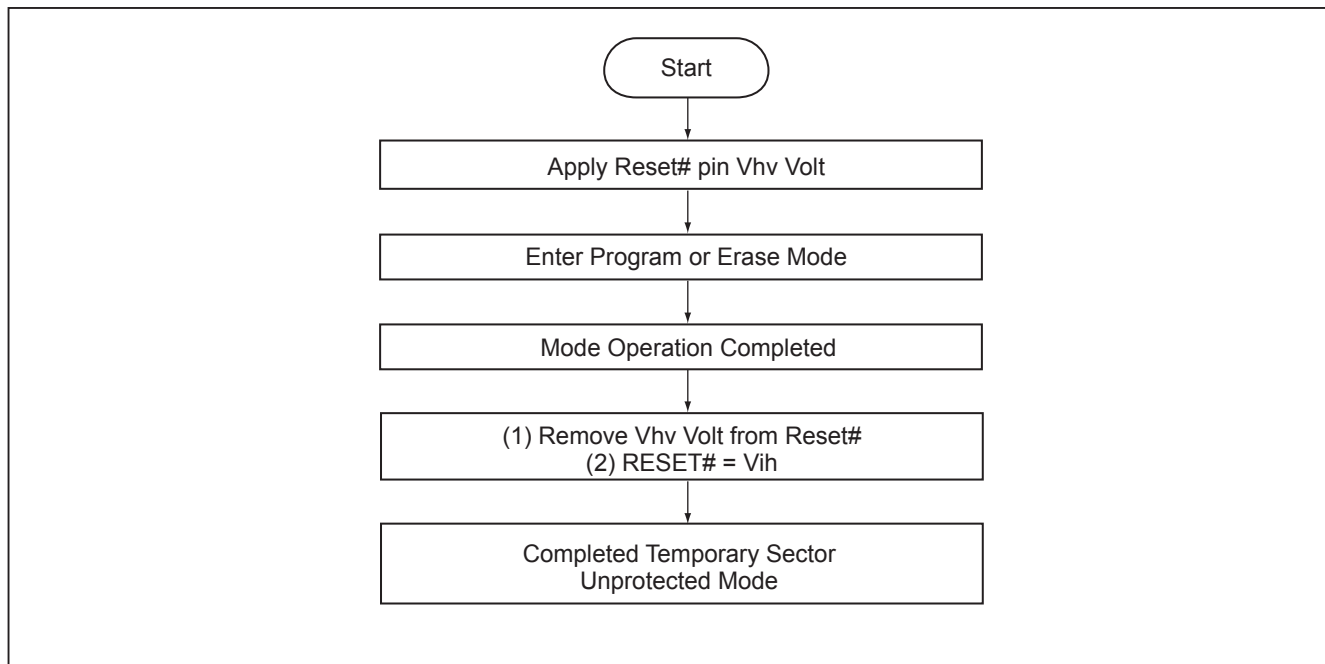
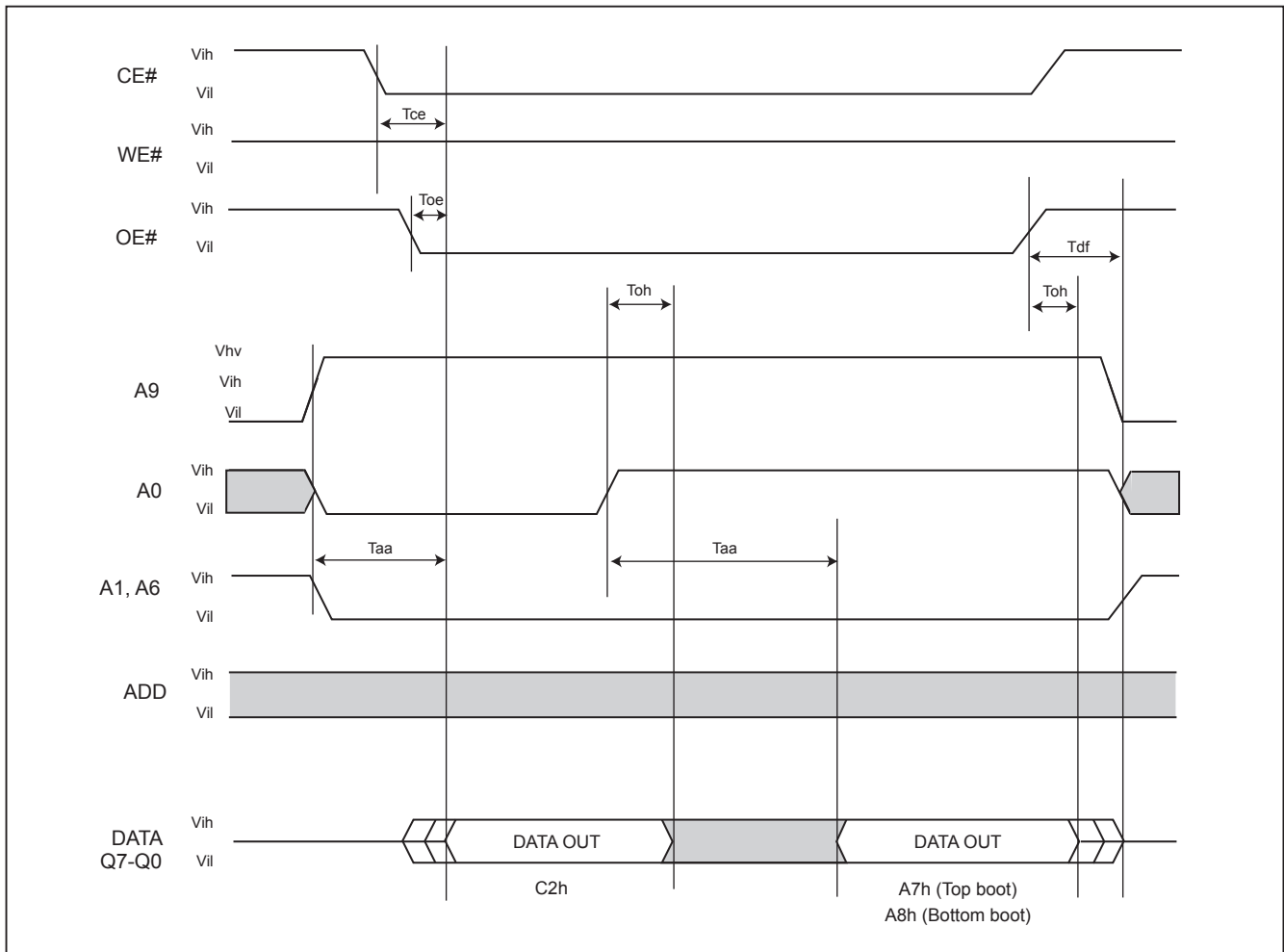


Figure 17. TEMPORARY SECTOR GROUP UNPROTECT FLOWCHART**Notes:**

1. Temporary unprotect all protected sectors Vhv=9.5~10.5V.
2. After leaving temporary unprotect mode, the previously protected sectors are again protected.

Figure 18. SILICON ID READ TIMING WAVEFORM



WRITE OPERATION STATUS

Figure 19. DATA# POLLING TIMING WAVEFORM (DURING AUTOMATIC ALGORITHM)

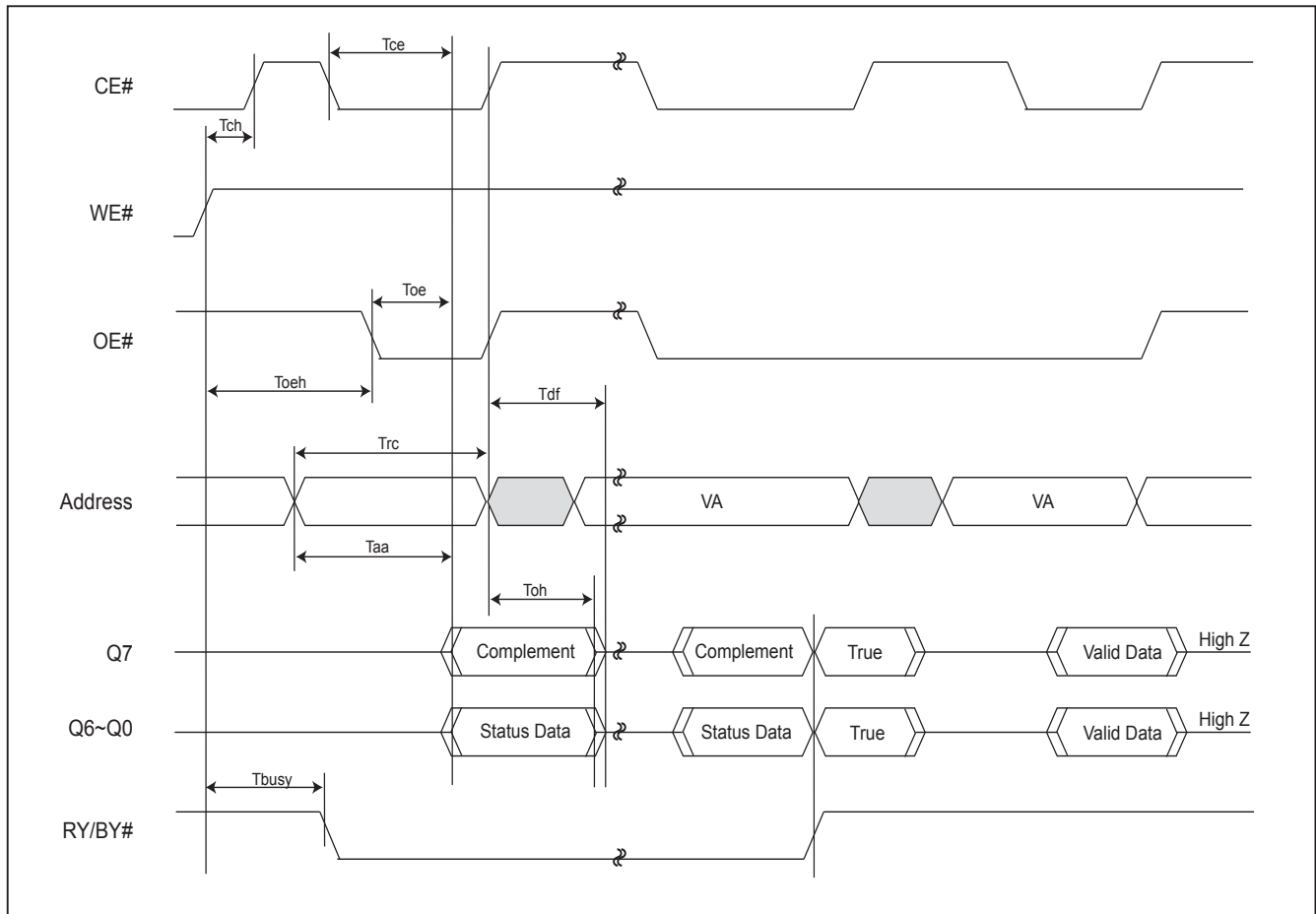
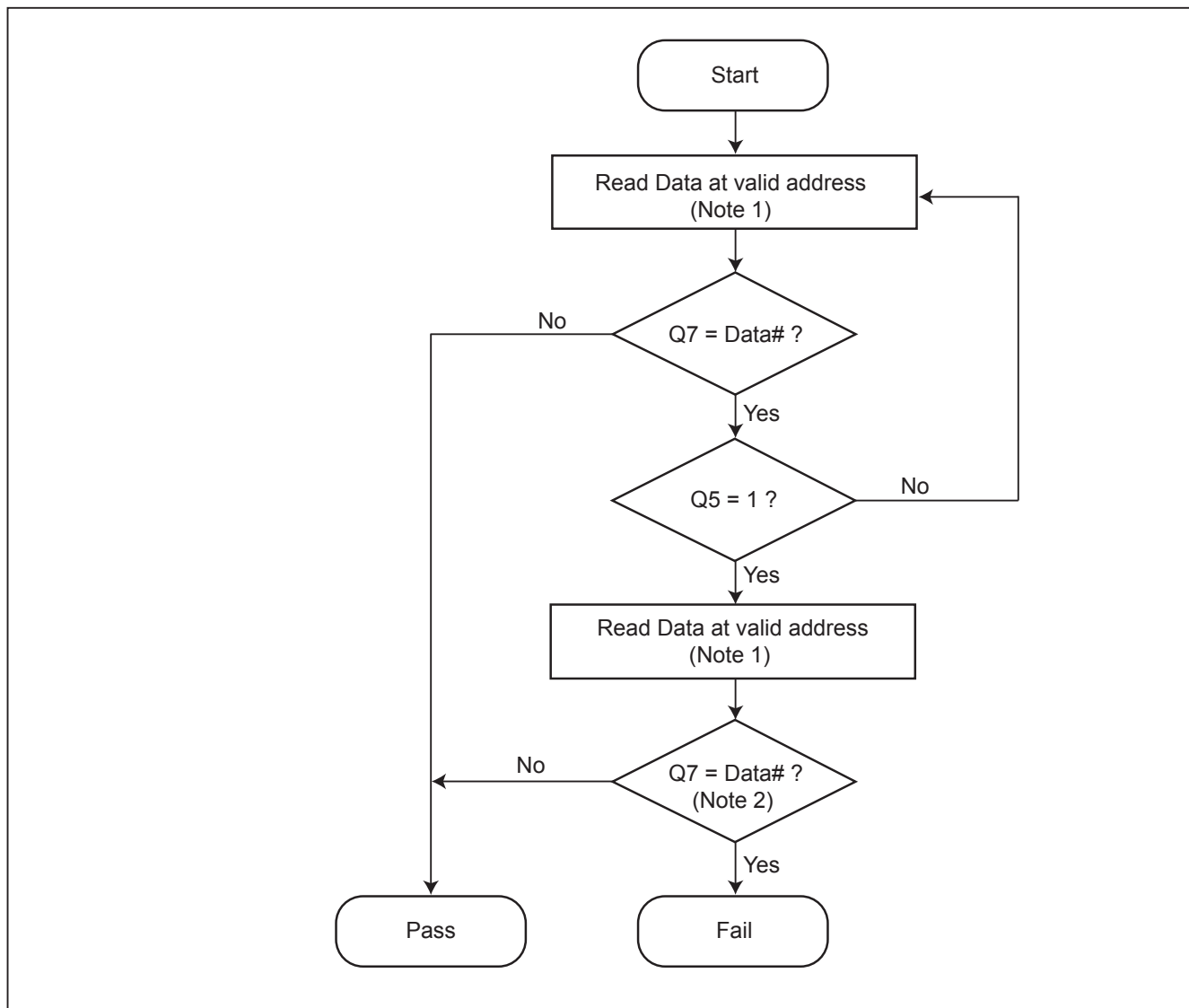


Figure 20. DATA# POLLING ALGORITHM



Notes:

1. For programming, valid address means program address.
For erasing, valid address means erase sectors address.
2. Q7 should be rechecked even Q5="1" because Q7 may change simultaneously with Q5.

Figure 21. TOGGLE BIT TIMING WAVEFORM (DURING AUTOMATIC ALGORITHM)

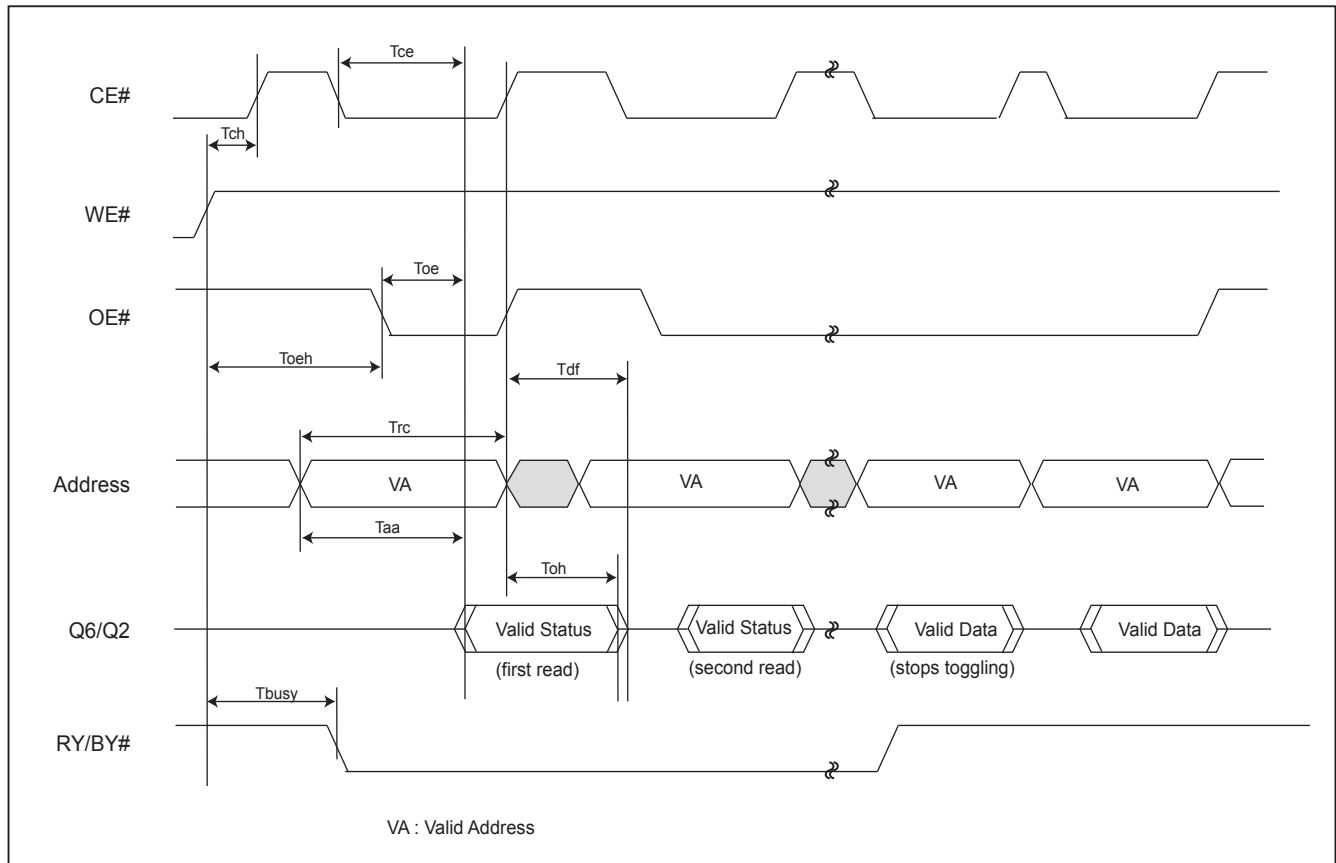
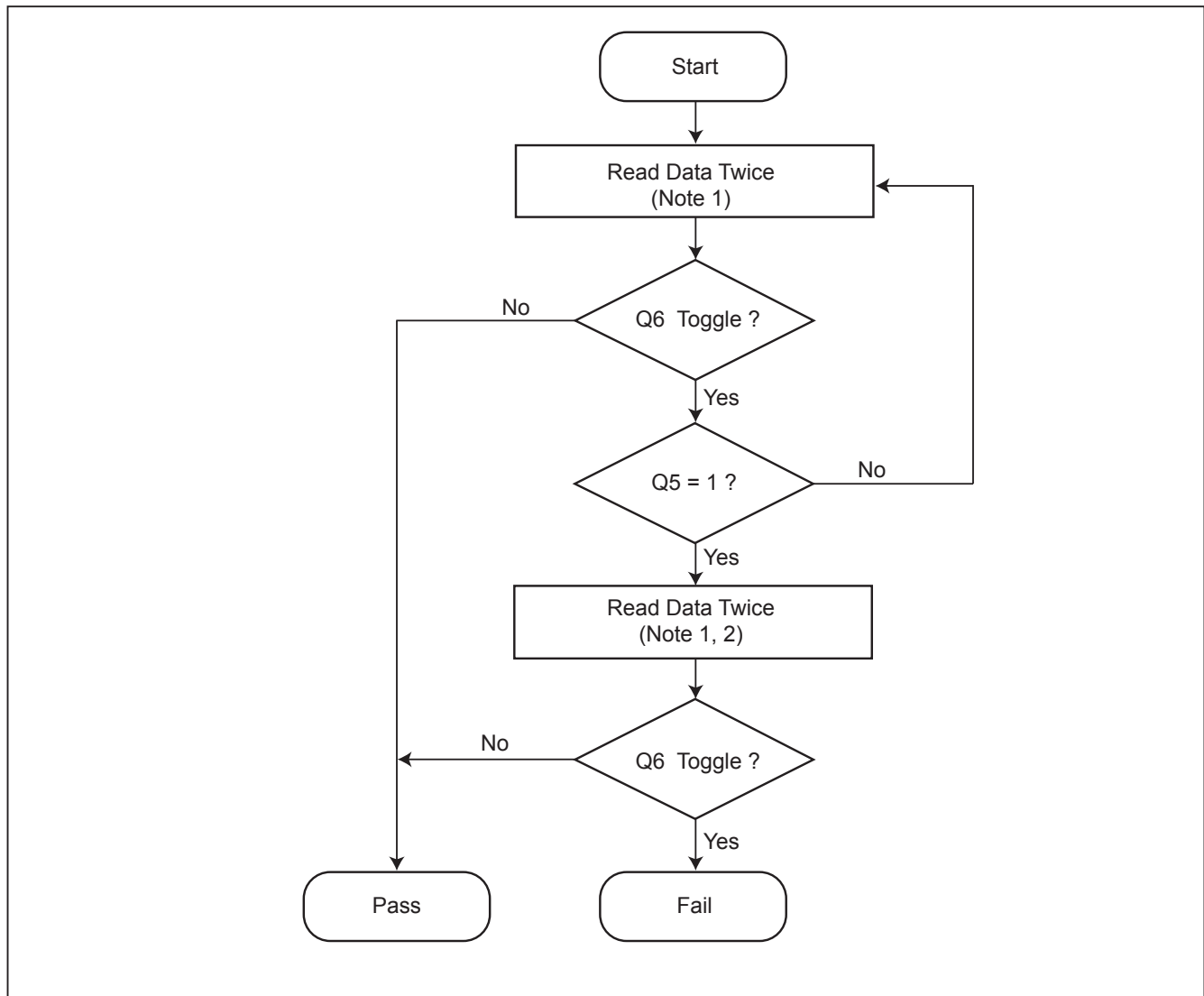


Figure 22. TOGGLE BIT ALGORITHM**Notes:**

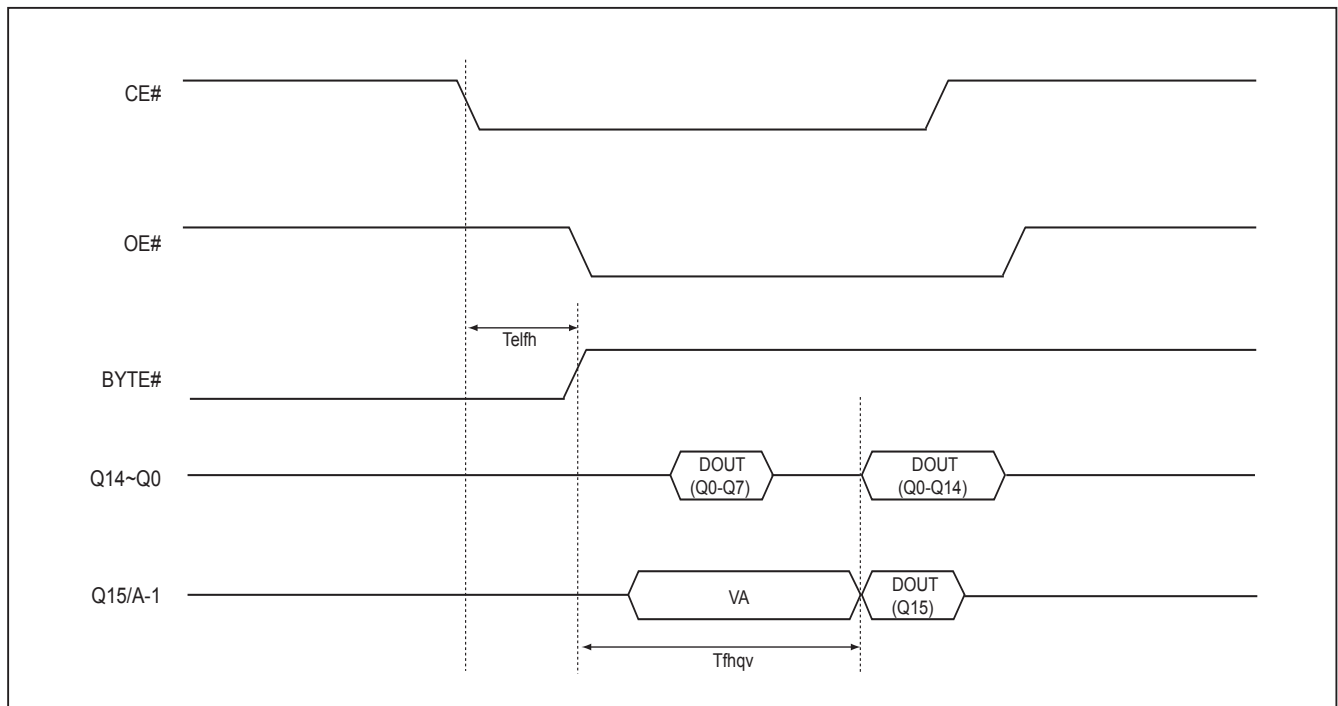
1. Read toggle bit twice to determine whether or not it is toggling.
2. Recheck toggle bit because it may stop toggling as Q5 changes to "1".

AC CHARACTERISTICS

WORD/BYTE CONFIGURATION (BYTE#)

Parameter	Description		Speed Options	Unit
			70	
Telf/Telfh	CE# to BYTE# from L/H	MAX	5	ns
Tflqz	BYTE# from L to Output Hiz	MAX	25	ns
Tfhqv	BYTE# from H to Output Active	MIN	70	ns

Figure 23. BYTE# TIMING WAVEFORM FOR READ OPERATIONS (BYTE# switching from byte mode to word mode)



RECOMMENDED OPERATING CONDITIONS

At Device Power-Up

AC timing illustrated in Figure A is recommended for the supply voltages and the control signals at device power-up (e.g. Vcc and CE# ramp up simultaneously). If the timing in the figure is ignored, the device may not operate correctly.

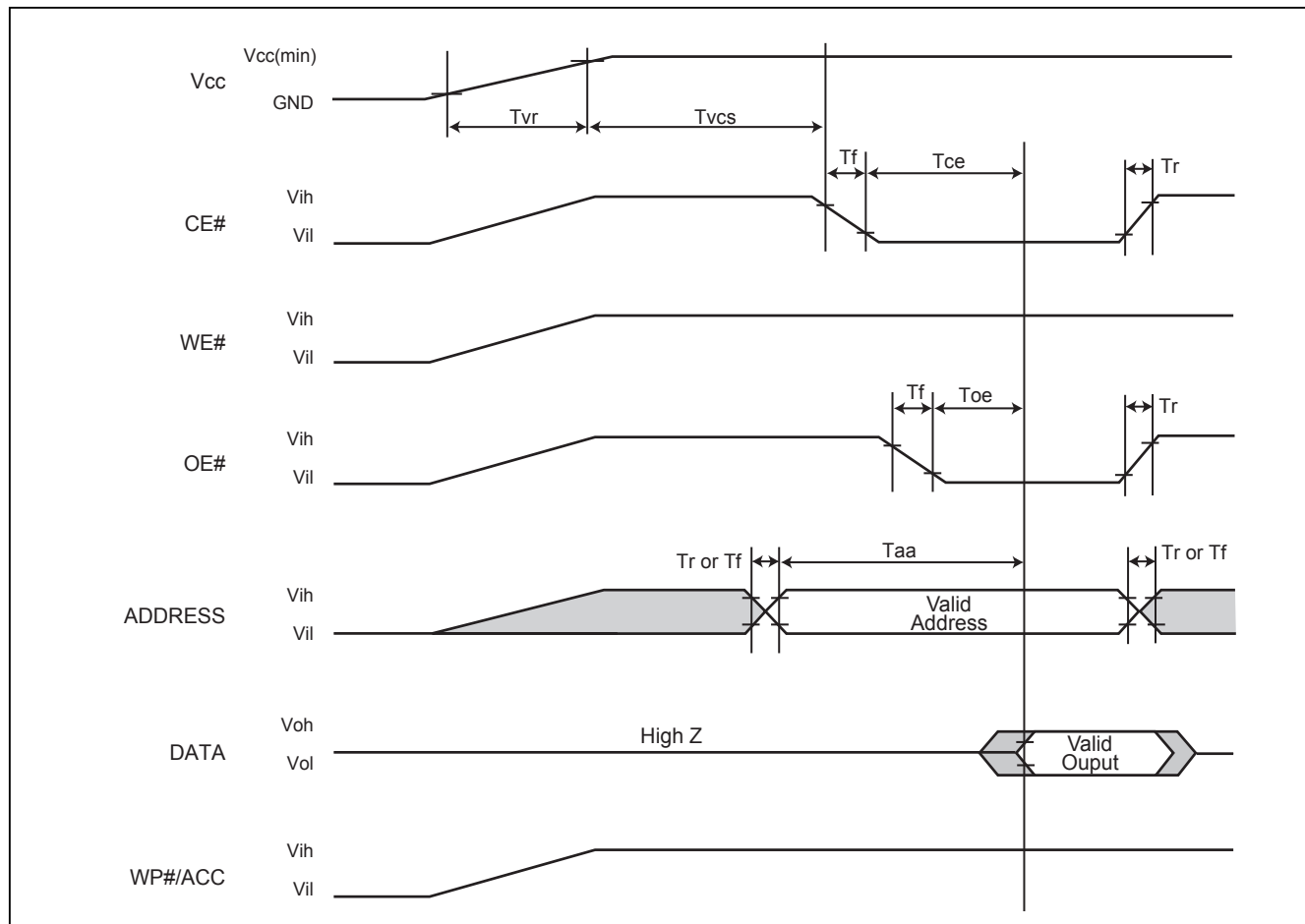


Figure A. AC Timing at Device Power-Up

Symbol	Parameter	Min.	Max.	Unit
Tvr	Vcc Rise Time	20	500000	us/V
Tr	Input Signal Rise Time		20	us/V
Tf	Input Signal Fall Time		20	us/V
Tvcs	Vcc Setup Time	200		us

Notes:

1. Not test 100%.

ERASE AND PROGRAMMING PERFORMANCE

PARAMETER	LIMITS			UNITS
	MIN.	TYP.	MAX.	
Chip Erase Time		35	50	sec
Sector Erase Time		0.7	2	sec
Erase/Program Cycles		100,000		Cycles
Chip Programming Time	Byte Mode	36	108	sec
	Word Mode	24	72	sec
Accelerated Byte/Word Program Time		7	210	us
Word Program Time		11	360	us
Byte Programming Time		9	300	us

Notes:

1. Typical program and erase times assume the following conditions: 25°C, 3.0V VCC. Programming specifications assume checkboard data pattern.
2. Maximum values are measured at VCC = 3.0 V, worst case temperature. Maximum values are valid up to and including 100,000 program/erase cycles.
3. Erase/Program cycles comply with JEDEC JESD-47 & 22-A117 standard.

DATA RETENTION

PARAMETER	Condition	Min.	Max.	UNIT
Data retention	55°C	20		years

LATCH-UP CHARACTERISTICS

	MIN.	MAX.
Input voltage difference with GND on all pins except I/O pins	-1.0V	10.5V
Input voltage difference with GND on all I/O pins	-1.0V	1.5 x Vcc
Vcc Current	-100mA	+100mA

All pins included except Vcc. Test conditions: Vcc = 3.0V, one pin per testing

TSOP PIN CAPACITANCE

Parameter Symbol	Parameter Description	Test Set	TYP	MAX	UNIT
CIN2	Control Pin Capacitance	VIN=0	7.5	9	pF
COUT	Output Capacitance	VOOUT=0	8.5	12	pF
CIN	Input Capacitance	VIN=0	6	7.5	pF

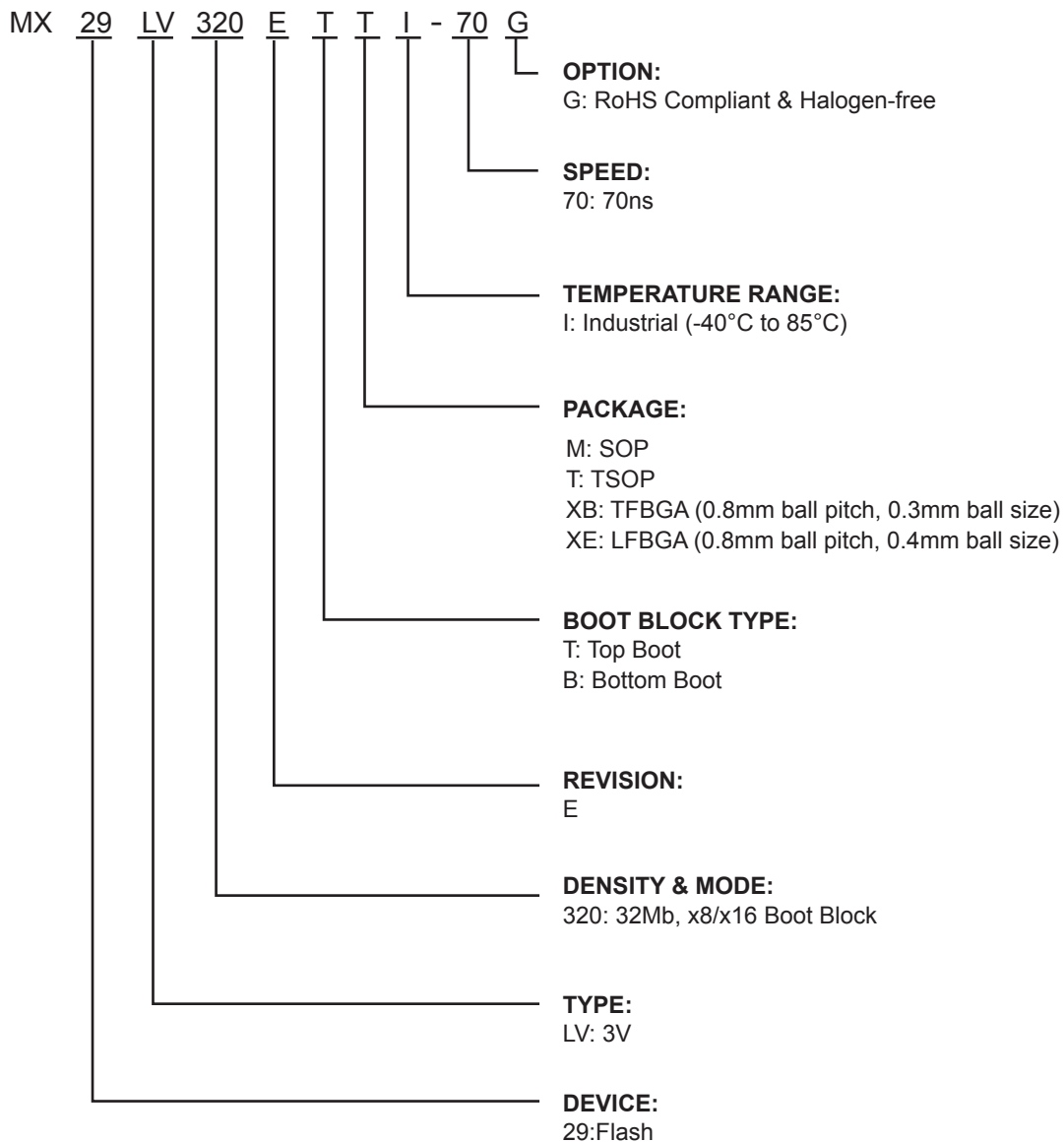


ORDERING INFORMATION

PART NO.	ACCESS TIME (ns)	Ball Pitch/ Ball Size	PACKAGE
MX29LV320ETMI-70G *	70	-	44 Pin SOP
MX29LV320ETTI-70G	70	-	48 Pin TSOP
MX29LV320EBTI-70G	70	-	48 Pin TSOP
MX29LV320ETXBI-70G	70	0.8mm/0.3mm	48-Ball TFBGA
MX29LV320EBXBI-70G	70	0.8mm/0.3mm	48-Ball TFBGA
MX29LV320ETXEI-70G	70	0.8mm/0.4mm	48-Ball LFBGA
MX29LV320EBXEI-70G	70	0.8mm/0.4mm	48-Ball LFBGA

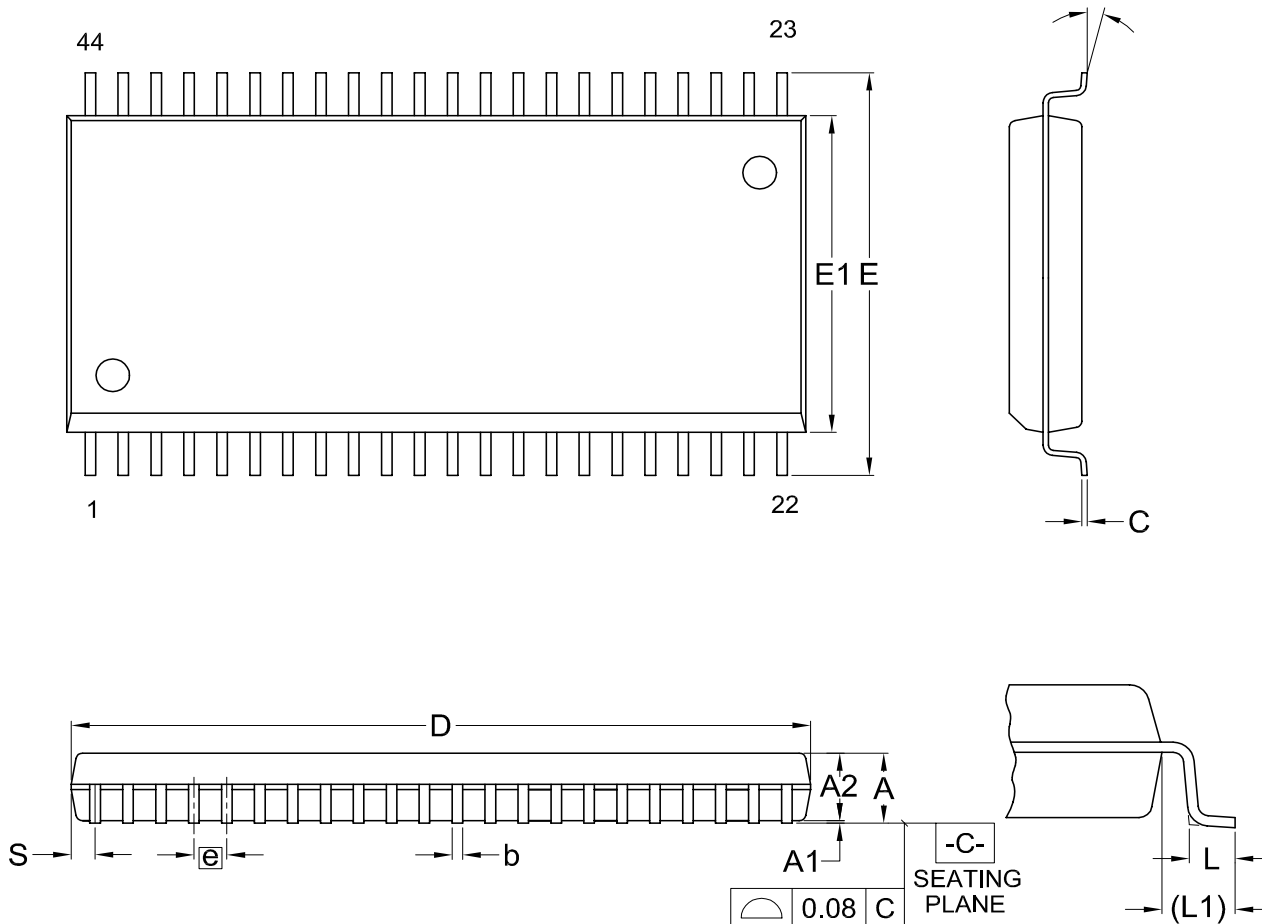
* 44-pin SOP is only for Pachinko Socket.

PART NAME DESCRIPTION



PACKAGE INFORMATION

Doc. Title: Package Outline for SOP 44L (500MIL)

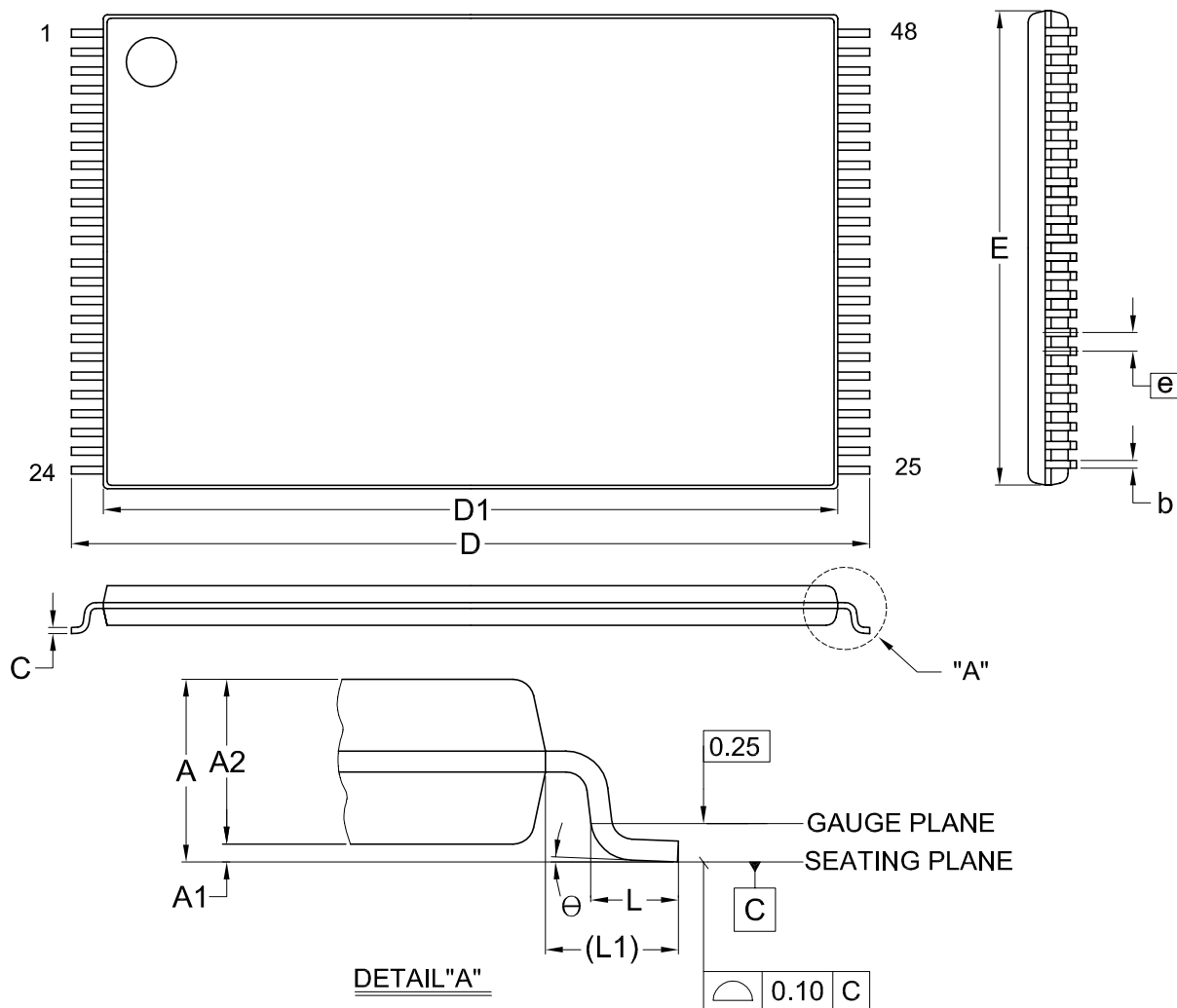


Dimensions (inch dimensions are derived from the original mm dimensions)

SYMBOL		A	A1	A2	b	C	D	E	E1	e	L	L1	S	⊖
UNIT														
mm	Min.	---	0.10	2.59	0.36	0.15	28.37	15.83	12.47	—	0.56	1.51	0.78	0
	Nom.	---	0.15	2.69	0.41	0.20	28.50	16.03	12.60	1.27	0.76	1.71	0.91	5
	Max.	3.00	0.20	2.80	0.51	0.25	28.63	16.23	12.73	—	0.96	1.91	1.04	10
Inch	Min.	---	0.004	0.102	0.014	0.006	1.117	0.623	0.491	---	0.022	0.059	0.031	0
	Nom.	---	0.006	0.106	0.016	0.008	1.122	0.631	0.496	0.050	0.030	0.067	0.036	5
	Max.	0.118	0.008	0.110	0.020	0.010	1.127	0.639	0.501	---	0.038	0.075	0.041	10

Dwg. No.	Revision	Reference		
		JEDEC	EIAJ	
6110-1405	8	MO-175		

Doc. Title: Package Outline for TSOP(I) 48L (12X20mm)NORMAL FORM



Dimensions (inch dimensions are derived from the original mm dimensions)

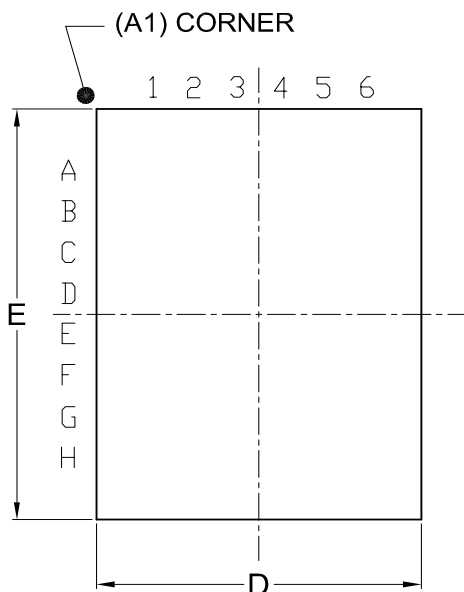
SYMBOL		A	A1	A2	b	C	D	D1	E	e	L	L1	θ
UNIT													
mm	Min.	---	0.05	0.95	0.17	0.10	19.80	18.30	11.90	---	0.50	0.70	0
	Nom.	---	0.10	1.00	0.20	0.13	20.00	18.40	12.00	0.50	0.60	0.80	5
	Max.	1.20	0.15	1.05	0.27	0.21	20.20	18.50	12.10	---	0.70	0.90	8
Inch	Min.	---	0.002	0.037	0.007	0.004	0.780	0.720	0.469	---	0.020	0.028	0
	Nom.	---	0.004	0.039	0.008	0.005	0.787	0.724	0.472	0.020	0.024	0.031	5
	Max.	0.047	0.006	0.041	0.011	0.008	0.795	0.728	0.476	---	0.028	0.035	8

Dwg. No.	Revision	Reference		
		JEDEC	EIAJ	
6110-1607	9	MO-142		

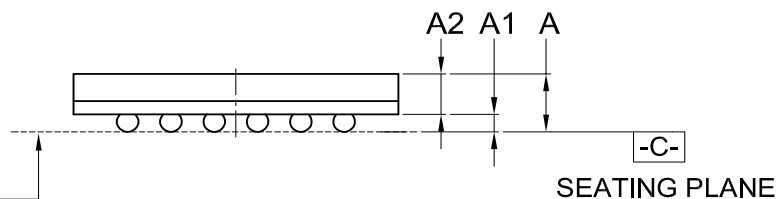
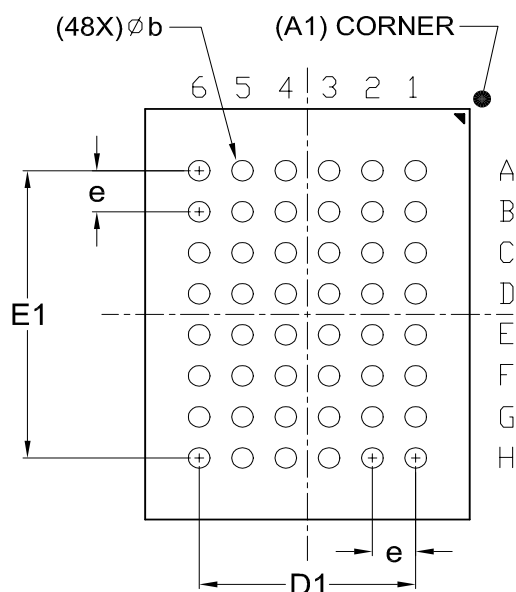
48-Ball TFBGA (for MX29LV320E TXBI/BXBI)

Doc. Title: Package Outline for CSP 48BALL(6X8X1.2MM,BALL PITCH 0.8MM,BALL DIAMETER 0.3MM)

TOP VIEW



BOTTOM VIEW



Dimensions (inch dimensions are derived from the original mm dimensions)

SYMBOL		A	A1	A2	b	D	D1	E	E1	e
mm	Min.	---	0.18	0.65	0.25	5.90		7.90		
	Nom.	---	0.23	---	0.30	6.00	4.00	8.00	5.60	0.80
	Max.	1.20	0.28	---	0.35	6.10		8.10		
Inch	Min.	---	0.007	0.026	0.010	0.232		0.311		
	Nom.	---	0.009	---	0.012	0.236	0.157	0.315	0.220	0.031
	Max.	0.047	0.011	---	0.014	0.240		0.319		

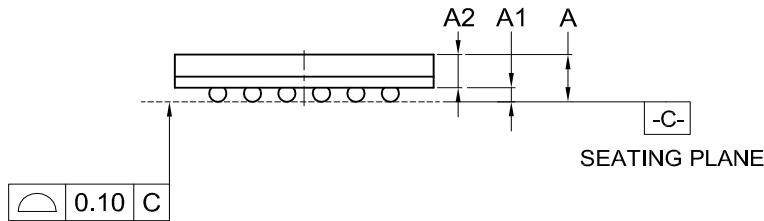
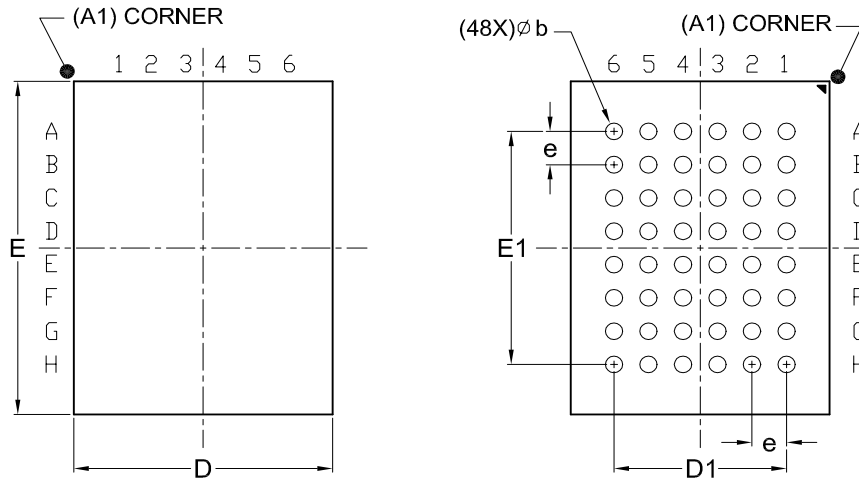
Dwg. No.	Revision	Reference		
		JEDEC	EIAJ	
6110-4201	7	MO-210		

48-Ball LFBGA (for MX29LV320E TXE1/BXE1)

Doc. Title: Package Outline for CSP 48BALL(6X8X1.3MM,BALL PITCH 0.8MM,BALL DIAMETER 0.4MM)

TOP VIEW

BOTTOM VIEW



Dimensions (inch dimensions are derived from the original mm dimensions)

SYMBOL		A	A1	A2	b	D	D1	E	E1	e
mm	Min.	---	0.25	0.65	0.35	5.90		7.90		
	Nom.	---	0.30	---	0.40	6.00	4.00	8.00	5.60	0.80
	Max.	1.30	0.35	---	0.45	6.10		8.10		
Inch	Min.	---	0.010	0.026	0.014	0.232		0.311		
	Nom.	---	0.012	---	0.016	0.236	0.157	0.315	0.220	0.031
	Max.	0.051	0.014	---	0.018	0.240		0.319		

Dwg. No.	Revision	Reference		
		JEDEC	EIAJ	
6110-4202	5	MO-219		



REVISION HISTORY

Revision No.	Description	Page	Date
1.0	1. Removed "Advanced Information"	P5	MAY/27/2010
	2. Revised Table 4-4. CFI Mode: Primary Vendor-Specific Extended Query Data Values	P32	
	3. Revised ORDERING INFORMATION	P61	
1.1	1. Revised General Description-security sector size	P6	JUN/14/2010
	2. Revised ORDERING INFORMATION	P61	
1.2	1. Added Top/Bottom Boot Security Sector Addresses tables	P12,14	MAY/23/2011
	2. Modified Security Sector Flash Memory Region description	P27	
	3. Modified description for RoHS compliance	P6,61,62	
1.3	1. Added value for Output enable hold time (Toggle & Data# Polling)	P36	DEC/19/2013
	2. Added (e.g. Vcc and CE# ramp up simultaneously) wording	P59	
	3. Added notes for Device Power-Up	P59	
	4. Removed "Advanced Information"	P61	



MACRONIX
INTERNATIONAL Co., LTD.

MX29LV320E T/B

Except for customized products which have been expressly identified in the applicable agreement, Macronix's products are designed, developed, and/or manufactured for ordinary business, industrial, personal, and/or household applications only, and not for use in any applications which may, directly or indirectly, cause death, personal injury, or severe property damages. In the event Macronix products are used in contradicted to their target usage above, the buyer shall take any and all actions to ensure said Macronix's product qualified for its actual use in accordance with the applicable laws and regulations; and Macronix as well as it's suppliers and/or distributors shall be released from any and all liability arisen therefrom.

Copyright© Macronix International Co., Ltd. 2010~2013. All rights reserved, including the trademarks and tradename thereof, such as Macronix, MXIC, MXIC Logo, MX Logo, Integrated Solutions Provider, NBit, Nbit, NBit, Macronix NBit, eLiteFlash, HybridNVM, HybridFlash, XtraROM, Phines, KH Logo, BE-SONOS, KSMC, Kingtech, MXSMIO, Macronix vEE, Macronix MAP, Rich Audio, Rich Book, Rich TV, and FitCAM. The names and brands of third party referred thereto (if any) are for identification purposes only.

For the contact and order information, please visit Macronix's Web site at: <http://www.macronix.com>

MACRONIX INTERNATIONAL CO., LTD. reserves the right to change product and specifications without notice.
