

Audio FM processor for VHS hi-fi audio

TDA9610H

FEATURES

- Integrated High Frequency (HF) low-pass filter (LPF) and summator
- Low-noise Phase-Locked Loop (PLL) FM (de)modulator
- Low-distortion sample-and-hold switching noise suppressor
- Integrated audio low-pass filter
- 4 stereo input selectors (left [L] and right [R] channel):
 - EXT1L and EXT1R
 - EXT2L and EXT2R
 - CINL and CINR
 - TUNL and TUNR
- Additional mono inputs for linear audio: EXN1 and EXN2
- DC output for VU meter drive
- Direct headphone drive
- Linear input/linear output
- Modulator output with overload Automatic Gain Control (AGC)
- RAF (Record Audio FM) for head amplifier control
- Power-down mode facility
- I²C-bus control of:
 - line input volume
 - headphone output volume
 - input/output selector
 - PAL/NTSC mode
- E-E performance (record + playback):
 - Total Harmonic Distortion (THD): 0.05% (–8 dBV, 1 kHz)
 - linearity error: 0.1 dB (–88 dBV)
 - noise: –93 dBV (20 Hz to 20 kHz).



GENERAL DESCRIPTION

The TDA9610H is a dual audio FM processing IC for VHS hi-fi audio, digitally controlled via the I²C-bus. The FM (de)modulator and peak noise reduction functions are highly integrated, resulting in few external components and adjustments.

In addition special functions for audio editing, mixing and dubbing have been implemented.

ORDERING INFORMATION

TYPE NUMBER	PACKAGE		
	NAME	DESCRIPTION	VERSION
TDA9610H	QFP64 ⁽¹⁾	plastic quad flat package; 64 leads (lead length 1.95 mm); body 14 × 20 × 2.8 mm	SOT319-2

Note

1. When using IR reflow soldering it is recommended that the Drypack instructions in the "Quality Reference Handbook" (order number 9398 510 63011) are followed.

Audio FM processor for VHS hi-fi audio

TDA9610H

BLOCK DIAGRAM

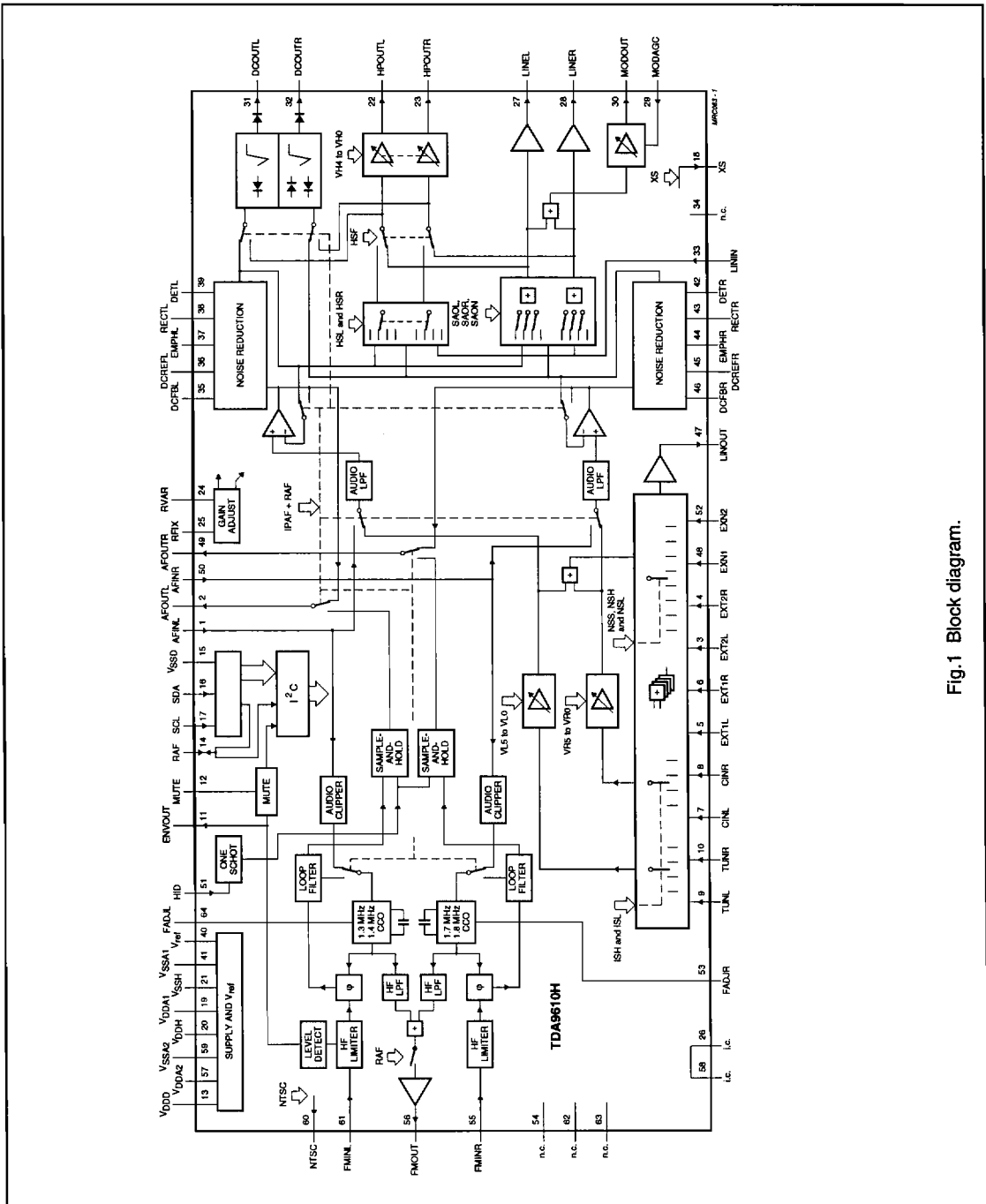

Fig.1 Block diagram.

Audio FM processor for VHS hi-fi audio

TDA9610H

PINNING

SYMBOL	PIN	DESCRIPTION
AFINL	1	audio input for either audio clipper (record) or noise reduction (playback) of left channel
AFOUTL	2	audio output from either sample-and-hold (playback) or noise reduction (record and loop-through) of left channel
EXT2L	3	input selector for left channel
EXT2R	4	input selector for right channel
EXT1L	5	input selector for left channel
EXT1R	6	input selector for right channel
CINL	7	input selector for left channel
CINR	8	input selector for right channel
TUNL	9	input selector for left channel
TUNR	10	input selector for right channel
ENVOUT	11	level detector output; external capacitor required for filtering
MUTE	12	mute timing; external capacitor required for timing playback mute
V _{DDD}	13	digital supply voltage (+5 V)
RAF	14	overrule the I ² C-bit RAF input or record/playback switch drive output for head amplifier control
V _{SSD}	15	I ² C-bus digital ground
SDA	16	I ² C-bus data input
SCL	17	I ² C-bus clock input
XS	18	auxiliary switch; digital output controlled by I ² C-bit XS
V _{D_{DA1}}	19	analog supply voltage 1 (+12 V)
V _{DDH}	20	headphone supply voltage (+12 V)
V _{SSH}	21	headphone ground
HPOUTL	22	headphone drive output left
HPOUTR	23	headphone drive output right
RVAR	24	gain adjustment of noise reduction by means of a resistor to ground
RFIX	25	fixed bias current generation circuit by using an external 100 k Ω resistor to ground
i.c.	26	pin internally connected to die pad; preferably connected to ground
LINEL	27	line output left
LINER	28	line output right
MODAGC	29	RF modulator AGC-time constant
MODOUT	30	RF modulator drive output
DCOUTL	31	VU meter drive output left
DCOUTR	32	VU meter drive output right
LININ	33	linear input
n.c.	34	not connected
DCFBL	35	DC feedback left
DCREFL	36	DC reference left
EMPHL	37	total emphasis left (20 to 240 μ s)

Audio FM processor for VHS hi-fi audio

TDA9610H

SYMBOL	PIN	DESCRIPTION
RECTL	38	rectifier DC decoupling left
DETL	39	attack/recovery timing left
V _{ref}	40	noise filtering of 3.8 V reference voltage; external capacitor required for filtering
V _{SSA1}	41	analog ground for LF circuits
DETR	42	attack/recovery timing right
RECTR	43	rectifier DC decoupling right
EMPHR	44	total emphasis right (20 to 240 µs)
DCREFR	45	DC reference right
DCFBR	46	DC feedback left
LINOUT	47	linear output
EXN1	48	EXN input (external normal input); mono input selectable to linear output
AFOUTR	49	audio output from either sample-and-hold (playback) or noise reduction (record and loop-through) of right channel
AFINR	50	audio input for either audio clipper (record) or noise reduction (playback) of right channel
HID	51	head identification pulse input for sample-and-hold circuits
EXN2	52	EXN input (external normal input); mono input selectable to linear output
FADJR	53	frequency adjustment of right channel oscillator by means of a variable resistor
n.c.	54	not connected; preferably connected to ground
FMINR	55	1.7 to 1.8 MHz input for limiter
FMOU	56	FM output
V _{DDA2}	57	analog supply voltage (+5 V)
i.c.	58	pin internally connected to die pad; preferably connected to ground
V _{SSA2}	59	analog ground for HF circuits
NTSC	60	digital output controlled by I ² C-bit NTSC
FMINL	61	1.3 to 1.4 MHz input for limiter
n.c.	62	not connected; preferably connected to ground
n.c.	63	not connected; preferably connected to ground
FADJL	64	frequency adjustment of left channel oscillator by means of a variable resistor

Audio FM processor for VHS hi-fi audio

TDA9610H

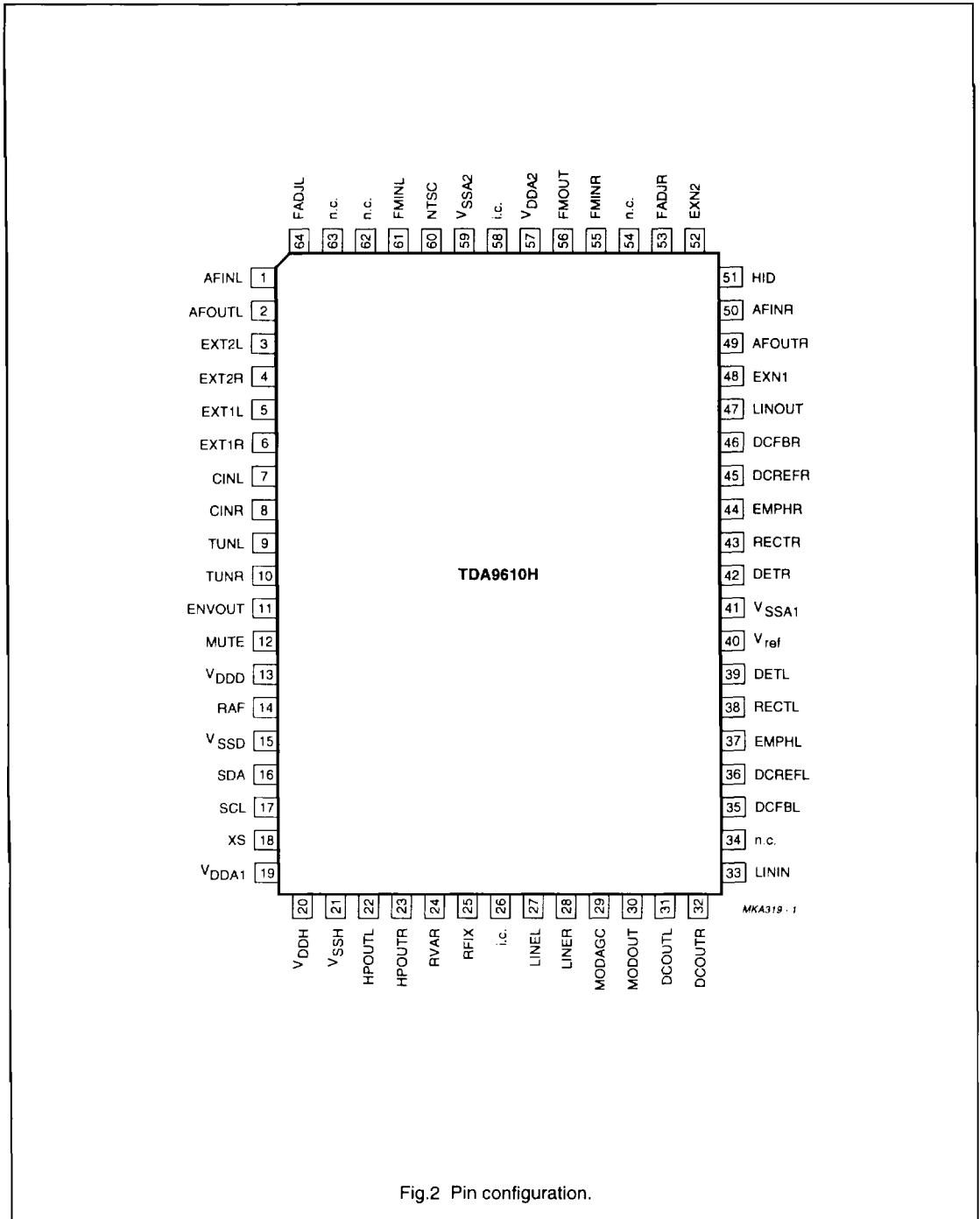

Fig.2 Pin configuration.

Audio FM processor for VHS hi-fi audio

TDA9610H

FUNCTIONAL DESCRIPTION

The IC is intended for use within the audio FM system of VHS video recorders. Three modes of operation can be distinguished:

- Record mode
- Playback mode
- Loop-through mode.

Switching and control of the three modes is done by the I²C-bus.

Record mode

The audio signal, selected from the four stereo audio inputs (EXT1L, EXT1R, EXT2L, EXT2R, CINL, CINR, TUNL and TUNR), is fed to the volume control stage (separate for left [L] and right [R]). The information for LINOUT is, after summing of L and R, derived from either one of the four stereo inputs or the volume control output or one of the mono inputs (EXN1 and EXN2). After the Low-Pass Filter (LPF) and signal compression in the noise reduction (NR) and filter block the audio signal is available at AFOUTL and AFOUTR. The compressed signal is now FM modulated on a RF carrier in the PLL block. After low-pass filtering and summation of both RF carriers (L and R) the signal is available at FMOUT.

The output select block offers the possibility to choose eight different audio signal modes:

1. Stereo.
2. Left.
3. Right.
4. Mono.
5. Normal.
6. Mixed stereo (stereo + LININ).
7. Mixed left (left + LININ).
8. Mixed right (right + LININ).

These audio signal modes are selectable for the output stages LINEL, LINER and MODOUT. The standard audio output is LINEL and LINER, e.g. for SCART output. MODOUT is a mono audio output, with an overload-protecting AGC, to drive an external RF modulator.

The headphone select block offers the possibility to choose either the output select signal or four independent audio signal modes (stereo, left, right and normal) for the output stages HPOUTL and HPOUTR.

HPOUTL and HPOUTR, with common volume control for L and R, is suitable for direct headphone drive.

DCOUTL and DCOUTR are intended for VU meter drive. It is connected to the selected stereo audio input after the volume control block. The output signal at DCOUTL and DCOUTR is proportional to the square root of the recorded audio signal (see Fig.3).

Playback mode

The two FM modulated RF carriers, present at the two FMINL and FMINR inputs after being band-pass filtered, are demodulated in the PLL block. The LF audio signal is fed through a sample-and-hold circuit to suppress head-switching noise. The demodulated audio signal is available at AFOUTL and AFOUTR. The audio signal is low-pass filtered and expanded in the noise reduction (NR) and filter block. The resulting audio signal is available after the output and headphone select blocks for all four output stages (LINEL, LINER, MODOUT, HPOUTL, HPOUTR, DCOUTL and DCOUTR). The functionality of the output and headphone select blocks is identical to the record mode. During playback DCOUTL and DCOUTR are connected to the headphone select block.

The functionality of the input and normal select blocks is also identical to record mode (see Fig.3), which offers the possibility to control (other) audio signals independently for LINOUT (see Fig.4).

Loop-through mode

This mode is similar to the record mode (see Fig.3), except for the FMOUT pin, which is inactive, and the RAF output which is active LOW (see Fig.5).

Audio FM processor for VHS hi-fi audio

TDA9610H

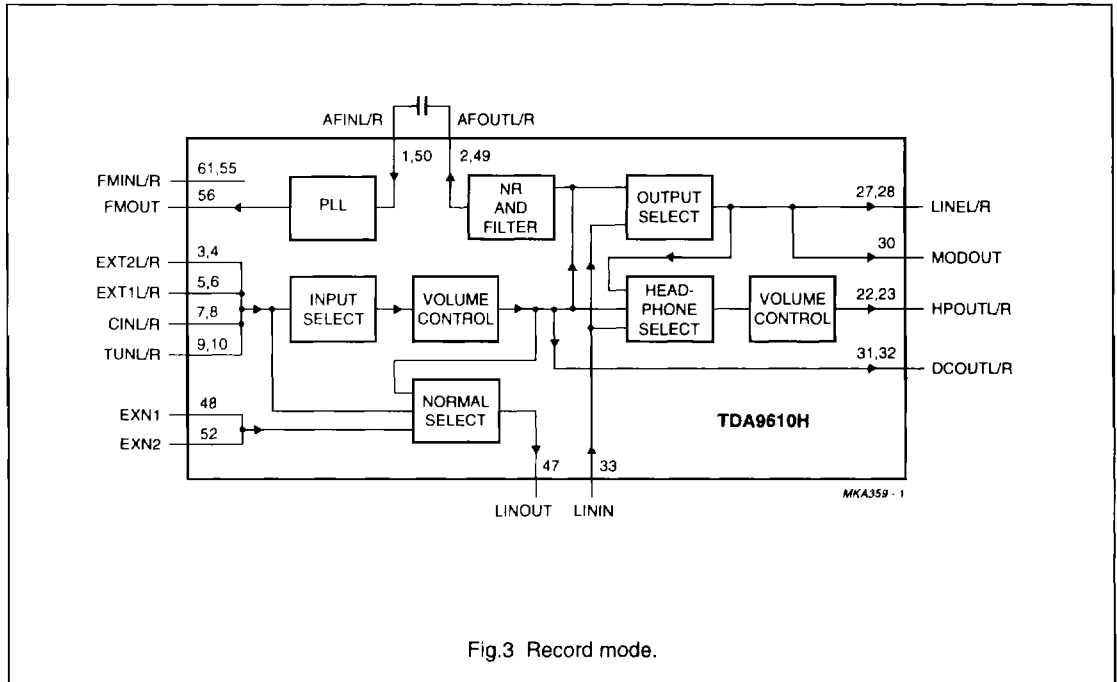

Fig.3 Record mode.

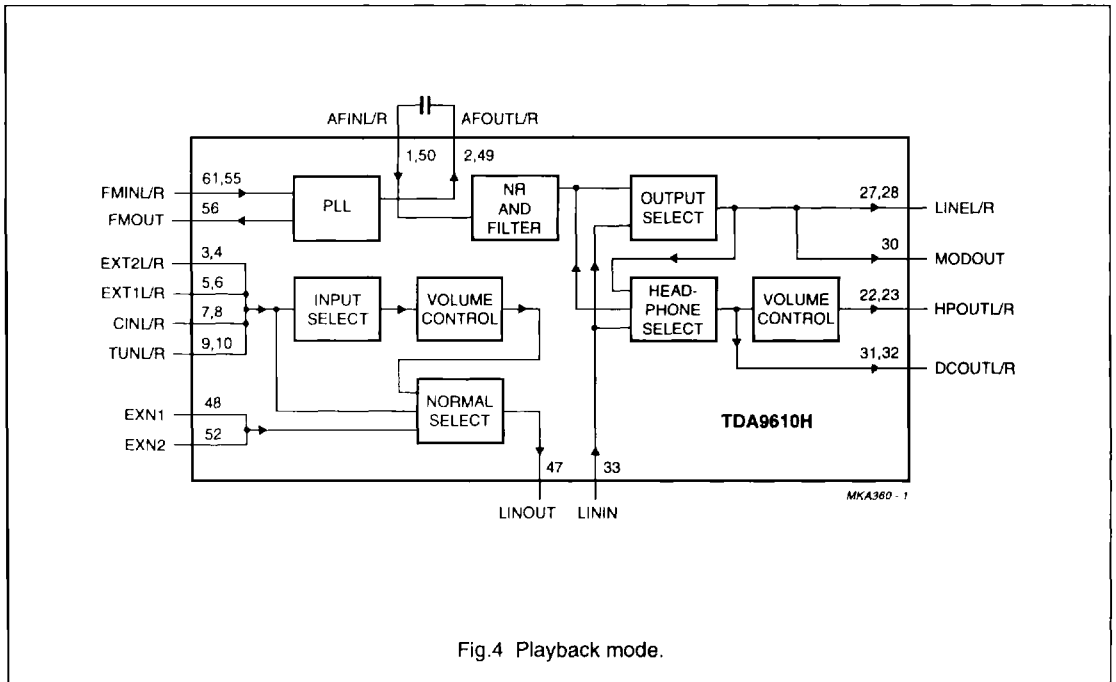

Fig.4 Playback mode.

Audio FM processor for VHS hi-fi audio

TDA9610H

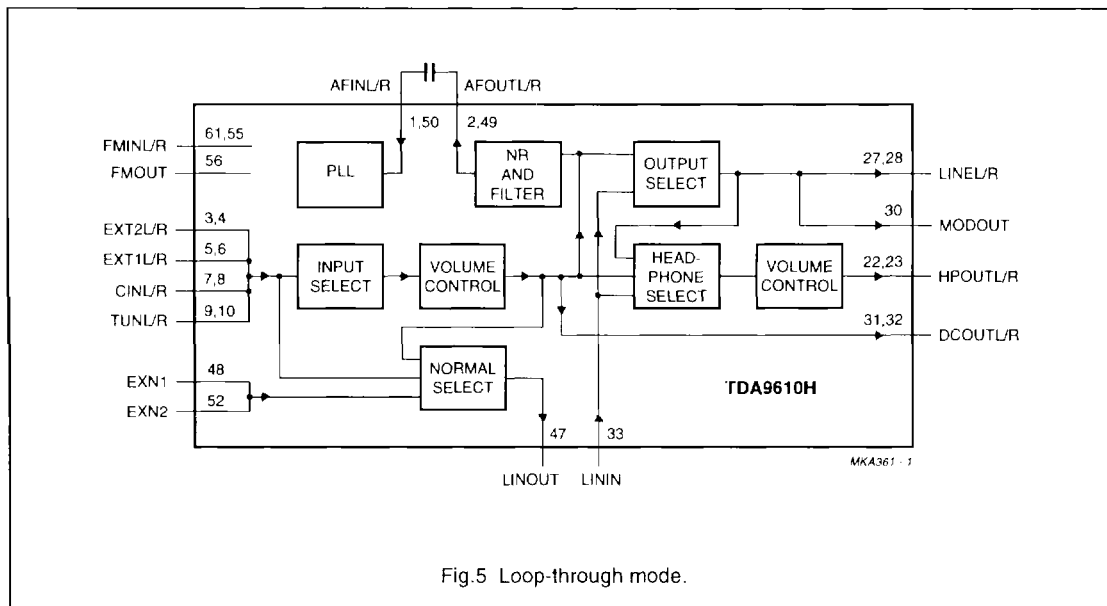

Fig.5 Loop-through mode.

I²C-bus

Bus specification in accordance with I²C-bus specification. Full details of the I²C-bus are given in the document "The I²C-bus and how to use it". This document may be ordered using the code 9398 393 40011.

The address and data bytes of the TDA9610H are shown in Table 1.

Table 1 TDA9610H address and data bytes

NAME	ADDRESS								
Slave address (B8)	1	0	1	1	1	0	0	0	
Control byte ⁽¹⁾	0	0	0	IPAF	RAF	NTSC	PAFM	MUTE	
Select byte ⁽²⁾	0	0	1	SAOL	SAOR	SAON	HSF	NSS	
Input byte ⁽³⁾	0	1	1	0	ISH	ISL	NSH	NSL	
Function byte ⁽⁴⁾	0	1	1	1	HSL	HSR	XS	TEST	
Record volume left byte ⁽⁵⁾	1	0	VL5	VL4	VL3	VL2	VL1	VL0	
Record volume right byte ⁽⁵⁾	1	1	VR5	VR4	VR3	VR2	VR1	VR0	
Headphone volume byte ⁽⁶⁾	0	1	0	VH4	VH3	VH2	VH1	VH0	

Notes

1. See Section "Control byte".
2. See Section "Select byte".
3. See Section "Input byte".
4. See Section "Function byte".
5. See Section "Record volume left and right byte".
6. See Section "Headphone volume byte".

Audio FM processor for VHS hi-fi audio

TDA9610H

Power-On Reset (POR); derived from digital supply V_{DD}

In the data byte descriptions [por] indicates the mode after POR.

The status of the data bytes after POR is shown in Table 2.

Table 2 TDA9610H address and data bytes after POR

NAME	ADDRESS							
Control byte ⁽¹⁾	0	0	0	1	0	0	0	1
Select byte ⁽²⁾	0	0	1	1	1	0	0	0
Input byte ⁽³⁾	0	1	1	0	0	0	0	0
Function byte ⁽⁴⁾	0	1	1	1	0	0	0	0
Record volume left byte ⁽⁵⁾	1	0	1	1	0	0	0	1
Record volume right byte ⁽⁵⁾	1	1	1	1	0	0	0	1
Headphone volume byte ⁽⁶⁾	0	1	0	1	0	1	1	1

Notes

1. See Section "Control byte".
2. See Section "Select byte".
3. See Section "Input byte".
4. See Section "Function byte".
5. See Section "Record volume left and right byte".
6. See Section "Headphone volume byte".

Audio FM processor for VHS hi-fi audio

TDA9610H

Control byte**Table 3** Bits of control byte

BIT	DESCRIPTION
IPAF	Inverse Playback Audio FM; see Table 4
RAF	Record Audio FM; see Table 4
NTSC	National Television Standards Committee; television standard; see Table 5
PAFM	Playback Audio FM Mute; see Table 6
MUTE	Mute; see Table 7

Table 4 Bits IPAF and RAF

IPAF	RAF ⁽¹⁾	MODE	DESCRIPTION
0	0	playback	NR and modem in playback mode
1	0	loop-through	NR in record mode; modem not active [por]
0	1	record ⁽²⁾	NR and modem in record mode
1	1	record ⁽²⁾	NR and modem in record mode

Notes

1. The RAF bit can be overruled externally by applying a low-ohmic voltage to the RAF I/O (pin 14) either logic 0 or logic 1 (0 or +5 V). The actual mode of the IC is determined by the level measured at this pin.
2. The two record modes are equal, only differing in their reaction to forcing RAF LOW at the RAF I/O pin; the status of the IPAF bit determines whether the IC is switched to the playback or loop-through mode.

Table 5 Bit NTSC

NTSC	MODE	DESCRIPTION
0	PAL	modem set to PAL carrier frequencies [por]
1	NTSC	modem set to NTSC carrier frequencies

Table 6 Bit PAFM

PAFM ⁽¹⁾	MODE	DESCRIPTION
0	-	
1	PB mute	the signal from the modem is muted in playback mode

Note

1. Bit PAFM has the same effect as the internally generated mute signal from the modem part when no FM carrier is detected during playback mode. If one (or both) of these signals is HIGH, the audio signal coming from the modem is muted.

Table 7 Bit MUTE

MUTE	MODE	DESCRIPTION
0	-	
1	full mute	all audio outputs are muted [por]

Audio FM processor for VHS hi-fi audio

TDA9610H

Select byte**Table 8** Bits of select byte

BIT	DESCRIPTION
SAOL	Select Audio Output Left; see Table 9
SAOR	Select Audio Output Right; see Table 9
SAON	Select Audio Output Normal; see Table 9
HSF	Headphone Select Function; see Table 10
NSS	Normal Special Select; see Table 11

Table 9 Bits SAOL, SAOR and SAON; note 1

SAOL	SAOR	SAON	MODE	DESCRIPTION
1	1	0	stereo	left at LINEL, right at LINER [por]
1	0	0	left	left at both LINEL and LINER
0	1	0	right	right at both LINEL and LINER
0	0	0	mono	left + right added at both LINEL and LINER (hi-fi mono)
1	1	1	mixed stereo	left + normal added at LINEL, right + normal added at LINER
1	0	1	mixed left	left + normal added at both LINEL and LINER
0	1	1	mixed right	right + normal added at both LINEL and LINER
0	0	1	normal	normal (is linear audio) at both LINEL and LINER

Note

1. The bits SAOL, SAOR and SAON provide eight output select functions, left and right are the left and right hi-fi channels, normal is the conventional audio channel, linear audio input (LININ; pin 33).

Table 10 Bit HSF; note 1

HSF	MODE	DESCRIPTION
0	–	headphone output signals identical to line outputs LINEL and LINER [por]
1	headphone select	headphone output signals independently selectable

Note

1. Normally the headphone outputs carry the same audio signal as present at the line outputs (LINEL and LINER), so the signal is selectable by means of the bits SAOL, SAOR and SAON. However when bit HSF is set HIGH, the headphone output has its own output select function switchable with bits HSL and HSR to stereo, left, right and normal (see Section "Function byte").

Table 11 Bit NSS; note 1

NSS	MODE	DESCRIPTION
0	–	signal at LINOUT is the mono version of selected stereo line input pair [por]
1	normal special select	special output signals selectable for LINOUT

Note

1. Normally the bits NSH and NSL select one of the four possible stereo line inputs (TUNL/R, CINL/R, EXT1L/R, EXT2L/R) as the source signal for linear out. Left and right channels of the selected input are added to give a mono signal as output.

When bit NSS is set HIGH, four special input selects can be made in combination with the same bits NSH and NSL; volume controlled, tuner left (TUNL), EXN1 and EXN2 (see Section "Input byte").

Audio FM processor for VHS hi-fi audio

TDA9610H

Input byte**Table 12** Bits of input byte

BIT	DESCRIPTION
ISH	Input Select HIGH; see Table 13
ISL	Input Select LOW; see Table 13
NSH	Normal Select HIGH; see Table 14
NSL	Normal Select LOW; see Table 14

Table 13 Bits ISH and ISL; note 1

ISH	ISL	MODE	DESCRIPTION
0	0	Tuner	TUNL and TUNR selected (as hi-fi stereo input source) [por]
0	1	Cinch	CINL and CINR selected
1	0	Ext1	EXT1L and EXT1R (e.g. Scart input) selected
1	1	Ext2	EXT2L and EXT2R selected

Note

- With bits ISH and ISL the stereo input signal is selected which is fed to the hi-fi processing. One out of four stereo sources can be selected. The terms: Tuner, Cinch, Ext1 and Ext2 are used for describing purposes only, technically all four inputs are equal (except for the fact that tuner left (TUNL, pin 6) is also selectable by Normal Select).

Table 14 Bits NSH, NSL and NSS; note 1

NSH	NSL	NSS ⁽²⁾	MODE	DESCRIPTION
0	0	0	Tuner	TUNL and TUNR selected (as normal audio input source) [por]
0	1	0	Cinch	CINL and CINR selected
1	0	0	Ext1	EXT1L and EXT1R selected
1	1	0	Ext2	EXT2L and EXT2R selected
0	0	1	Volume	hi-fi input source selected; taken after record volume control
0	1	1	Exn1	additional mono input (EXN1, pin 48) selected
1	0	1	Tuner left	only TUNL selected (e.g. dual language)
1	1	1	Exn2	additional mono input (EXN2, pin 52) selected

Notes

- With bits NSH and NSL in combination with bit NSS the input signal is selected which is fed out at pin 47 (LINOOUT). With bit NSS set LOW a selection can be made between the four stereo line inputs (like the hi-fi input select). With bit NSS set HIGH, bits NSH and NSL make a selection between four special select functions.

When a stereo input source is selected, both channels are added to obtain a mono output signal, then the output signal at LINOOUT is equal to: $\frac{(L + R)}{2}$

In the Volume mode the output signal is equal to: $\frac{(L \times \text{Volume Left} + R \times \text{Volume Right})}{2}$

Note that for the Volume mode the hi-fi input select (ISH and ISL) determines the used input source.

- NSS from select byte.

Audio FM processor for VHS hi-fi audio

TDA9610H

Function byte

Table 15 Bits of function byte

BIT	DESCRIPTION
HSL	Headphone Select Left; see Table 16
HSR	Headphone Select Right; see Table 16
XS	auxiliary Switch; see Table 17
TEST	Test; see Table 18

Table 16 Bits HSL, HSR and HSF; note 1

HSL	HSR	HSF ⁽²⁾	MODE	DESCRIPTION
1	1	0	outsel	headphone output signal identical to LINEL and LINER
1	0	0	outsel	headphone output signal identical to LINEL and LINER
0	1	0	outsel	headphone output signal identical to LINEL and LINER
0	0	0	outsel	headphone output signal identical to LINEL and LINER [por]
1	1	1	stereo	left at HPOUTL, right at HPOUTR
1	0	1	left	left at both HPOUTL and HPOUTR
0	1	1	right	right at both HPOUTL and HPOUTR
0	0	1	normal	normal (is linear audio) at both HPOUTL and HPOUTR

Notes

- Normally (bit HSF set LOW) the headphone outputs carry the same audio signal as present at the line outputs (LINEL and LINER), so the signal is selectable by means of the bits SAOL, SAOR and SAON. However, when bit HSF is set HIGH the headphone output has its own output select function switchable with bits HSL and HSR.
 - These special headphone selections are also active for the VU meter drive during playback.
- HSF from select byte.

Table 17 Bit XS

XS	MODE	DESCRIPTION
0	–	XS output LOW [por]
1	XS	XS output HIGH

Audio FM processor for VHS hi-fi audio

TDA9610H

Table 18 Bits TEST, HSL, HSR and XS; note 1

TEST ⁽²⁾	HSL	HSR	XS	MODE	DESCRIPTION
0	0	0	0	–	[por]
0	X	X	X	–	
1	0	0	X	–	
1	1	0	0	VCO test L	in record mode; only 1.4 or 1.3 MHz at output
1	0	1	0	VCO test R	in record mode; only 1.8 or 1.7 MHz at output
1	1	1	0	Test	not for application
1	1	0	1	Test	not for application
1	0	1	1	Test	not for application
1	1	1	1	Test	not for application

Notes

1. X = don't care.
2. With TEST bit set HIGH, the IC can be switched between several special modes for testing and adjustment purposes, by means of bits HSL and HSR.

Record volume left and right byte**Table 19** Record volume left/right byte; note 1

VL5	VL4	VL3	VL2	VL1	VL0	MUTE ⁽²⁾	MODE
VR5	VR4	VR3	VR2	VR1	VR0		
1	1	0	0	0	1	1	mute [por]
X	X	X	X	X	X	1	mute
0	0	0	0	0	0	0	mute
0	0	0	0	0	1	0	–48 dB
0	0	0	0	1	0	0	–47 dB
0	0	0	0	1	1	0	–46 dB
0	0	0	1	0	0	0	–45 dB
0	0	0	1	0	1	0	–44 dB
0	0	0	1	1	0	0	–43 dB
0	0	0	1	1	1	0	–42 dB
0	0	1	0	0	0	0	–41 dB
0	0	1	0	0	1	0	–40 dB
0	0	1	0	1	0	0	–39 dB
0	0	1	0	1	1	0	–38 dB
0	0	1	1	0	0	0	–37 dB
0	0	1	1	0	1	0	–36 dB
0	0	1	1	1	0	0	–35 dB
0	0	1	1	1	1	0	–34 dB
0	1	0	0	0	0	0	–33 dB
0	1	0	0	0	1	0	–32 dB
0	1	0	0	1	0	0	–31 dB

Audio FM processor for VHS hi-fi audio

TDA9610H

VL5	VL4	VL3	VL2	VL1	VL0	MUTE ⁽²⁾	MODE
VR5	VR4	VR3	VR2	VR1	VR0		
0	1	0	0	1	1	0	-30 dB
0	1	0	1	0	0	0	-29 dB
0	1	0	1	0	1	0	-28 dB
0	1	0	1	1	0	0	-27 dB
0	1	0	1	1	1	0	-26 dB
0	1	1	0	0	0	0	-25 dB
0	1	1	0	0	1	0	-24 dB
0	1	1	0	1	0	0	-23 dB
0	1	1	0	1	1	0	-22 dB
0	1	1	1	0	0	0	-21 dB
0	1	1	1	0	1	0	-20 dB
0	1	1	1	1	0	0	-19 dB
0	1	1	1	1	1	0	-18 dB
1	0	0	0	0	0	0	-17 dB
1	0	0	0	0	1	0	-16 dB
1	0	0	0	1	0	0	-15 dB
1	0	0	0	1	1	0	-14 dB
1	0	0	1	0	0	0	-13 dB
1	0	0	1	0	1	0	-12 dB
1	0	0	1	1	0	0	-11 dB
1	0	0	1	1	1	0	-10 dB
1	0	1	0	0	0	0	-9 dB
1	0	1	0	0	1	0	-8 dB
1	0	1	0	1	0	0	-7 dB
1	0	1	0	1	1	0	-6 dB
1	0	1	1	0	0	0	-5 dB
1	0	1	1	0	1	0	-4 dB
1	0	1	1	1	0	0	-3 dB
1	0	1	1	1	1	0	-2 dB
1	1	0	0	0	0	0	-1 dB
1	1	0	0	0	1	0	0 dB
1	1	0	0	1	0	0	1 dB
1	1	0	0	1	1	0	2 dB
1	1	0	1	0	0	0	3 dB
1	1	0	1	0	1	0	4 dB
1	1	0	1	1	0	0	5 dB
1	1	0	1	1	1	0	6 dB
1	1	1	0	0	0	0	7 dB
1	1	1	0	0	1	0	8 dB

Audio FM processor for VHS hi-fi audio

TDA9610H

VL5	VL4	VL3	VL2	VL1	VL0	MUTE ⁽²⁾	MODE
VR5	VR4	VR3	VR2	VR1	VR0		
1	1	1	0	1	0	0	9 dB
1	1	1	0	1	1	0	10 dB
1	1	1	1	0	0	0	11 dB
1	1	1	1	0	1	0	12 dB
1	1	1	1	1	0	0	13 dB
1	1	1	1	1	1	0	14 dB

Notes

1. X = don't care.
2. MUTE from control byte.

Headphone volume byte

Table 20 Headphone volume byte

VH4	VH3	VH2	VH1	VH0	MODE
0	0	0	0	0	mute
0	0	0	0	1	-44 dB
0	0	0	1	0	-42 dB
0	0	0	1	1	-40 dB
0	0	1	0	0	-38 dB
0	0	1	0	1	-36 dB
0	0	1	1	0	-34 dB
0	0	1	1	1	-32 dB
0	1	0	0	0	-30 dB
0	1	0	0	1	-28 dB
0	1	0	1	0	-26 dB
0	1	0	1	1	-24 dB
0	1	1	0	0	-22 dB
0	1	1	0	1	-20 dB
0	1	1	1	0	-18 dB
0	1	1	1	1	-16 dB
1	0	0	0	0	-14 dB
1	0	0	0	1	-12 dB
1	0	0	1	0	-10 dB
1	0	0	1	1	-8 dB
1	0	1	0	0	-6 dB
1	0	1	0	1	-4 dB
1	0	1	1	0	-2 dB
1	0	1	1	1	0 dB ⁽¹⁾
1	1	0	0	0	2 dB
1	1	0	0	1	4 dB

Audio FM processor for VHS hi-fi audio

TDA9610H

VH4	VH3	VH2	VH1	VH0	MODE
1	1	0	1	0	6 dB
1	1	0	1	1	8 dB
1	1	1	0	0	10 dB
1	1	1	0	1	12 dB
1	1	1	1	0	14 dB
1	1	1	1	1	16 dB

Note

1. This is the situation after Power-On Reset (POR).

LIMITING VALUES

In accordance with the Absolute Maximum Rating System (IEC 134).

SYMBOL	PARAMETER	MIN.	MAX.	UNIT
V_{DDA1}	analog supply voltage	0	13.2	V
V_{DDA2}	analog supply voltage	0	5.5	V
V_{DDH}	headphone supply voltage	0	13.2	V
V_{DDD}	digital supply voltage	0	5.5	V
V_n	voltage on pins: 1, 3, 4, 5, 6, 7, 8, 9, 10, 39, 42, 48, 50 and 52 11, 12, 56 and 60 14 and 18	0 0 0	7.7 V_{DDA2} V_{DDD}	V V V
T_{stg}	storage temperature	-65	+150	°C
T_{amb}	operating ambient temperature	0	+70	°C

HANDLING

All pins are meeting the ESD requirements.

Remark: Pin 1 showed a higher sensitivity during the latch-up test and was not fully meeting the test limits.

THERMAL CHARACTERISTICS

SYMBOL	PARAMETER	VALUE	UNIT
$R_{th\ j-a}$	thermal resistance from junction to ambient in free air	55	K/W

Audio FM processor for VHS hi-fi audio

TDA9610H

DC CHARACTERISTICS

$V_{DDA1} = 12\text{ V}$; $V_{DDA2} = 5\text{ V}$; $f_{OUTR} = 1.8\text{ MHz}$; $f_{OUTL} = 1.4\text{ MHz}$; NTSC = 0; $f_m = 1\text{ kHz}$; $T_{amb} = 25\text{ °C}$; all volume control levels set to 0 dB; measured in test circuit (see Fig.12); unless otherwise specified.

SYMBOL	PARAMETER	CONDITIONS	MIN.	TYP.	MAX.	UNIT
Supply voltages						
V_{DDA1}	analog supply voltage; pin 19		10.5	12	13.2	V
V_{DDA2}	analog supply voltage; pin 57		4.75	5	5.25	V
V_{DDH}	headphone supply voltage; pin 20		10.5	12	13.2	V
V_{DDD}	digital supply voltage; pin 13		4.75	5	5.25	V
Supply currents						
I_{DDA1}	analog supply current; pin 19		–	37	46	mA
I_{DDA2}	analog supply current; pin 57	record or loop-through	–	7	9	mA
		playback	–	10	13	mA
I_{DDH}	headphone supply current; pin 20		–	3.5	4.5	mA
I_{DDD}	digital supply current; pin 13		–	0.5	2	mA
Input voltages						
V_I	DC input voltage; pins 1, 3, 4, 5, 6, 8, 9, 10, 33, 48, 50, 52		–	3.8	–	V
$V_{55,61}$	DC input voltage internally generated; pins 55 and 61		–	0	–	V
Output voltages						
V_O	DC output voltage:					
	pins 27 and 28		–	6	–	V
	pins 22 and 23		–	5.5	–	V
	pins 2, 30, 40, 49, 53 and 64		–	3.8	–	V
	pin 47		–	6	–	V
	pin 24		–	0.5	–	V
	pin 25		–	2.0	–	V
pin 56	record mode		–	1.2	–	V
Head identification pulse input (HID; pin 51)						
V_{IH}	HIGH level input voltage		2.75	–	5.25	V
V_{IL}	LOW level input voltage		0	–	2.25	V
Auxiliary switch output (XS; pin 18)						
V_{OH}	HIGH level output voltage	$I_L = -500\text{ }\mu\text{A}$	$V_{DDD} - 0.5$	–	–	V
V_{OL}	LOW level output voltage	$I_L = 500\text{ }\mu\text{A}$	–	–	0.5	V
Digital output (NTSC; pin 60)						
V_{OH}	HIGH level output voltage	$I_L = -500\text{ }\mu\text{A}$	$V_{DDA2} - 0.5$	–	–	V
V_{OL}	LOW level output voltage	$I_L = 500\text{ }\mu\text{A}$	–	–	0.5	V

Audio FM processor for VHS hi-fi audio

TDA9610H

SYMBOL	PARAMETER	CONDITIONS	MIN.	TYP.	MAX.	UNIT
I/O RAF (pin 14); used as output						
V_{OH}	HIGH level output voltage	RAF = 1; $I_L = -35 \mu A$	$V_{DD} - 0.25$	–	V_{DD}	V
V_{OL}	LOW level output voltage	RAF = 0; $I_L = 185 \mu A$	0	–	0.4	V
I_{OH}	HIGH level output current (drive capability)	RAF = 1	–35	–	–	μA
I_{OL}	LOW level output current (drive capability)	RAF = 0	185	–	–	μA
I/O RAF (pin 14); used as input (output overruled)						
V_{IH}	HIGH level input voltage		3.5	–	V_{DD}	V
V_{IL}	LOW level input voltage		0	–	1.5	V
I_{IH}	HIGH level input current	at V_{IH}	–	–	345	μA
I_{IL}	LOW level input current	at V_{IL}	–	–	–65	μA

AC CHARACTERISTICS

Record mode

Audio input signal –8 dBV from TUNL and TUNR (pins 9 and 10).

SYMBOL	PARAMETER	CONDITIONS	MIN.	TYP.	MAX.	UNIT
Audio inputs (EXT1L, EXT1R, EXT2L, EXT2R, CINL, CINR, TUNL, TUNR, EXN1 and EXN2; pins 3, 4, 5, 6, 7, 8, 9, 10, 48 and 52)						
R_i	input resistance		100	130	–	k Ω
V_{IAF}	audio input voltage		–	–	8	dBV
Linear input (LININ; pin 33); select mode: linear						
R_i	input resistance	$V_i = -8 \text{ dBV}; f = 1 \text{ kHz}$	50	75	100	k Ω
V_o	line output voltage	$V_i = -8 \text{ dBV}; f = 1 \text{ kHz}$	–9	–8	–7	dBV
Line outputs (LINEL and LINER; pins 27 and 28)						
V_o	output voltage		–9	–8	–7	dBV
R_o	output resistance		–	200	275	Ω
THD	total harmonic distortion		–	0.01	0.1	%
V_o	output voltage	THD = 1%; $R_L = 5 \text{ k}\Omega$; $C_L = 2.2 \text{ nF}$; TUNL $\leq -3 \text{ dBV}$; TUNR $\leq -3 \text{ dBV}$; note 1	10	11	–	dBV
V_n	noise level	$f_i = 300 \text{ Hz to } 20 \text{ kHz}$	–	–92	–88	dBV
α_{cb}	channel balance		–1	–	+1	dB
V_m	volume mute level		–	–100	–80	dBV
α_{ct}	crosstalk between channels	one channel driven	–	–88	–80	dBV

Audio FM processor for VHS hi-fi audio

TDA9610H

SYMBOL	PARAMETER	CONDITIONS	MIN.	TYP.	MAX.	UNIT
f_{res}	frequency response with respect to 1 kHz; low-pass filter transfer	$f_i = 20$ kHz	-0.5	-	+0.5	dB
		$f_i = 60$ kHz	-	-9	-5	dB
α_{ct}	maximum audio input crosstalk	-8 dBV at a not selected stereo audio input	-	-85	-	dBV
VU meter drive (DCOUTL and DCOUTR; pins 31 and 32); square root of output voltage (see Fig.8)						
V_o	output voltage		1.6	1.8	2.0	V
R_o	output resistance		-	100	-	Ω
V_o	output voltage at maximum record level	TUNL = -3 dBV; TUNR = -3 dBV; note 1	$V_{DD} - 0.5$	-	V_{DD}	V
V_{oz}	output voltage for zero-level input		-	-	300	mV
RF modulator drive output; mono MODOUT; pin 30 (see Fig.9)						
V_o	output voltage		-10	-8	-6	dBV
R_o	output resistance		-	100	-	Ω
THD	total harmonic distortion		-	0.04	-	%
V_o	output voltage at maximum record level	TUNL = -3 dBV; TUNR = -3 dBV; note 1	-7	-4	-1	dBV
THD	total harmonic distortion at maximum record level	TUNL = -3 dBV; TUNR = -3 dBV; note 1	-	1	-	%
Linear output (LINOUT; pin 47); NSS = 0						
V_o	output voltage		-9	-8	-7	dBV
R_o	output resistance		-	200	-	Ω
THD	total harmonic distortion		-	0.01	-	%
V_n	noise level	$f_i = 300$ Hz to 20 kHz	-	-93	-	dBV
V_o	output voltage	THD = 1%; $R_L = 10$ k Ω ; TUNL \leq -3 dBV; TUNR \leq -3 dBV; NSS = 1; note 1	9	10	-	dBV
Headphone output (HPOUTL and HPOUTR; pins 22 and 23); headphone volume set to 0 dB						
V_o	output voltage		-9	-8	-7	dBV
R_o	output resistance		-	3	-	Ω
THD	total harmonic distortion		-	0.06	0.1	%
V_o	output voltage	THD = 1%; TUNL \leq -3 dBV; TUNR \leq -3 dBV; $R_L = 250$ Ω ; note 1	9.5	10.5	-	dBV

Audio FM processor for VHS hi-fi audio

TDA9610H

SYMBOL	PARAMETER	CONDITIONS	MIN.	TYP.	MAX.	UNIT
V_n	noise level	$f_i = 300$ Hz to 20 kHz; tuner AC short-circuited	–	–90	–80	dBV
α_{ct}	crosstalk between channels	one channel driven	–	–90	–70	dBV
V_{mute}	headphone volume mute level		–	–90	–70	dBV
α_{cb}	channel balance		–1	–	+1	dB
Audio outputs (AFOUTL and AFOUTR; pins 2 and 49); audio output from noise reduction						
V_{oAF}	audio output voltage		–13	–11.5	–10	dBV
THD	total harmonic distortion		–	0.15	0.3	%
V_{oAF}	audio output voltage at maximum record level	TUNL = –3 dBV; TUNR = –3 dBV; note 1	–3.5	–2	–0.5	dBV
THD	total harmonic distortion at maximum record level	TUNL = –3 dBV; TUNR = –3 dBV; note 1	–	0.4	3	%
V_n	noise level	$f_i = 300$ Hz to 20 kHz	–	–55	–52	dBV
α_{cb}	channel balance		–1	–	+1	dB
L	linearity	$V_i = -8$ to –68 dBV	28.5	30	31.5	dB
α_{cc}	channel crosstalk	one channel driven	–	–65	–50	dBV
t_{att}	attack time according VHS		–	5	–	ms
t_{rec}	recovery time according VHS		–	70	–	ms
V_{mute}	mute level	MUTE = 1	–	–52	–	dBV
	frequency response with respect to 1 kHz; output level	$f_i = 300$ Hz	–0.9	–0.2	+0.5	dB
		$f_i = 10$ kHz	2.9	3.9	4.9	dB
FM modulator (audio input from AFINL and AFINR; pins 1 and 50)						
THD	total harmonic distortion	$\Delta f = 50$ kHz	–	0.1	0.2	%
Δf	FM frequency deviation	$V_{iAF} = -11.5$ dBV	45	50	55	kHz
Δf_{max}	maximum FM frequency deviation		140	150	160	kHz
TC	temperature coefficient		–	± 50	–	$10^{-6}/K$
R_{fa}	frequency adjust resistor	left channel	22	28	35	k Ω
		right channel	17	22	28	k Ω
f_{oR}	FM centre frequency right	NTSC = 1	–	1700	–	kHz
f_{oL}	FM centre frequency left	NTSC = 1	–	1300	–	kHz
Δf	FM frequency deviation	NTSC = 1; $V_{iAF} = -11.5$ dBV	45	50	55	kHz
HF output stage (FMOUT; pin 56)						
$V_{oR(p-p)}$	right output voltage (peak-to-peak value)	$f_{oR} = 1.8$ MHz; 1 st harmonic	455	510	572	mV
$V_{oL(p-p)}$	left output voltage (peak-to-peak value)	$f_{oL} = 1.4$ MHz; 1 st harmonic	152	170	190	mV

Audio FM processor for VHS hi-fi audio

TDA9610H

SYMBOL	PARAMETER	CONDITIONS	MIN.	TYP.	MAX.	UNIT
$\frac{V_{oR}}{V_{oL}}$	ratio of output voltages		2.7	3	3.3	
α_{3rd}	3 rd harmonic suppression		20	30	–	dB
R_o	output resistance		–	100	130	Ω

Note

- Record volume control for left and right channel set to maximum (+14 dB). Headphone volume control at 0 dB.

Playback mode

Audio output signal from the FM (de)modulator at AFOUTL and AFOUTR (pins 2 and 49).

SYMBOL	PARAMETER	CONDITIONS	MIN.	TYP.	MAX.	UNIT
PLL FM demodulator and limiter						
α_{AM}	AM rejection	$V_{iHF} = 1$ to 100 mV; $m = 30\%$	–	–80	–	dBV
$V_{i(rms)}$	sensitivity; PLL locked (RMS value)	$\Delta f = 150$ kHz	–	–	0.6	mV
$V_{i max(rms)}$	maximum signal level (RMS value)		–	–	200	mV
THD	total harmonic distortion	$\Delta f = 50$ kHz	–	0.03	0.3	%
		$\Delta f = 150$ kHz	–	0.2	1	%
S/N	signal-to-noise ratio	$V_{iHF} = 30$ mV; $\Delta f = 50$ kHz	55	60	–	dB
V_{oAF}	AF output voltage	$\Delta f = 50$ kHz	–12.5	–11.5	–10.5	dBV
α_{cl}	crosstalk between channels	L to R; R to L	–	–90	–	dBV
Sample-and-hold (see Fig.10)						
t_h	hold pulse width		5	6	7	μs
d_{AF}	audio distortion	note 1	–	–	–76	dB
t_d	delay from HID pulse to hold pulse		–	0.15	–	μs
Mute timing (MUTE; pin 12)						
$V_{i(rms)}$	mute activation level (RMS value)		1.1	2.0	3.5	mV
t_{off}	switch-off duration	signal to no signal	–	15	–	ms
t_{on}	switch-on duration	no signal to signal	–	400	–	ms
Level detector output ENVOUT; pin 11 (see Fig.11)						
V_o	output voltage level	$V_{iHF(rms)} = 1$ mV	–	1.5	–	V
		$V_{iHF(rms)} = 10$ mV	–	3.1	–	V
		$V_{iHF(rms)} = 100$ mV	–	4.5	–	V
R_o	output resistance		–	20	–	k Ω
Line outputs (LINEL and LINER; pins 27 and 28); audio inputs at AFINL and AFINR (pins 1 and 50): –11.5 dBV						
V_o	output voltage		–11	–8	–5	dBV
V_n	noise level	$f_1 = 300$ Hz to 20 kHz	–	–93	–90	dBV

Audio FM processor for VHS hi-fi audio

TDA9610H

SYMBOL	PARAMETER	CONDITIONS	MIN.	TYP.	MAX.	UNIT
THD	total harmonic distortion		–	0.06	0.2	%
L	linearity	$V_{iAF} = -11.5$ to -41.5 dBV	57	60	63	dB
α_{cb}	channel balance		-2	–	+2	dB
f_{res}	frequency response with respect to 1 kHz; output level	$f_i = 300$ Hz	-1	+0.4	+1.8	dB
		$f_i = 10$ kHz	-9.7	-7.7	-5.7	dB
DC outputs (DCOUTL and DCOUTR; pins 31 and 32); square root of output voltage (see Fig.8)						
V_{oz}	output voltage for zero input level	HSF = 1	–	–	300	mV
		HSF = 0	–	–	440	mV

Note

- The audio distortion is measured with the HID pulse frequency set to 1 kHz (500 Hz input at pin 51). FM signal: $f_m = 10$ kHz; $\Delta f = 50$ kHz. The distortion is measured with a 3 kHz 4th-order low-pass filter. The measured value at 1 kHz HID-pulse frequency is corrected with 26 dB in order to calculate the equivalent distortion at 50 Hz HID-pulse frequency.

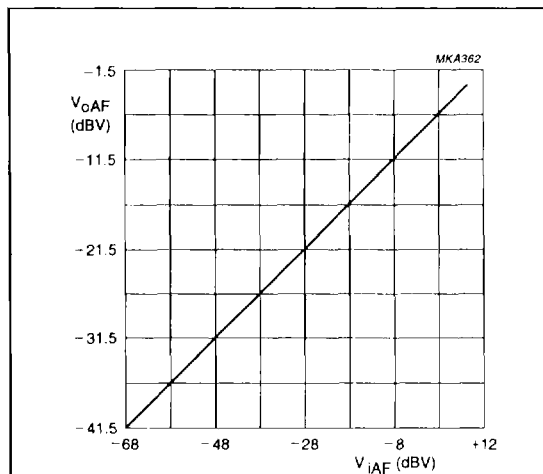

Fig.6 Compression curve of noise reduction at 1 kHz; record mode. The audio output voltage at AFOUTL and AFOUTR (pins 2 and 49) as a function of the audio input voltage at TUNL and TUNR (pins 9 and 10).

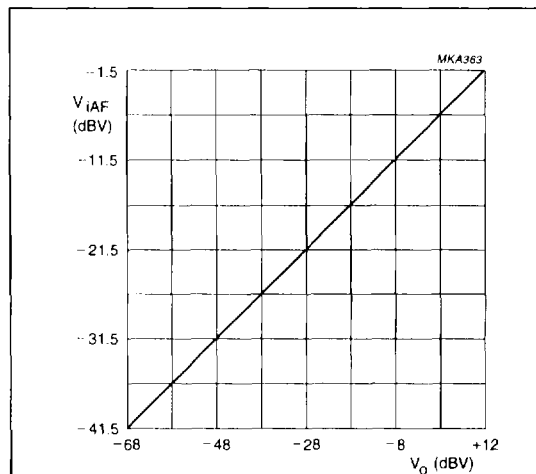

Fig.7 Expansion curve of noise reduction at 1 kHz; playback mode. The audio output voltage at LINEL and LINER (pins 27 and 28) as a function of the audio input voltage at AFINL and AFINR (pins 1 and 50).

Audio FM processor for VHS hi-fi audio

TDA9610H

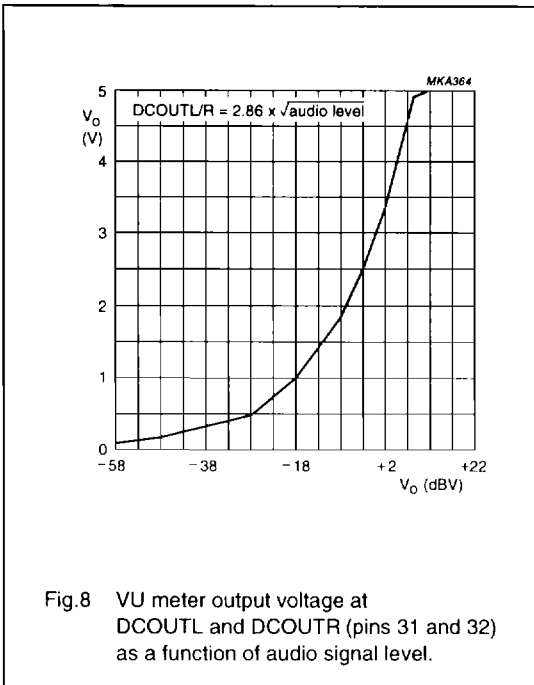

Fig.8 VU meter output voltage at DCOUTL and DCOUTR (pins 31 and 32) as a function of audio signal level.

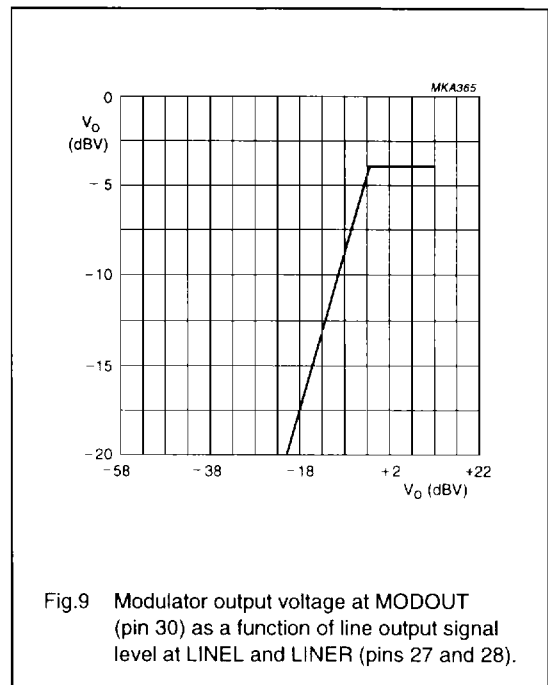

Fig.9 Modulator output voltage at MODOUT (pin 30) as a function of line output signal level at LINEL and LINER (pins 27 and 28).

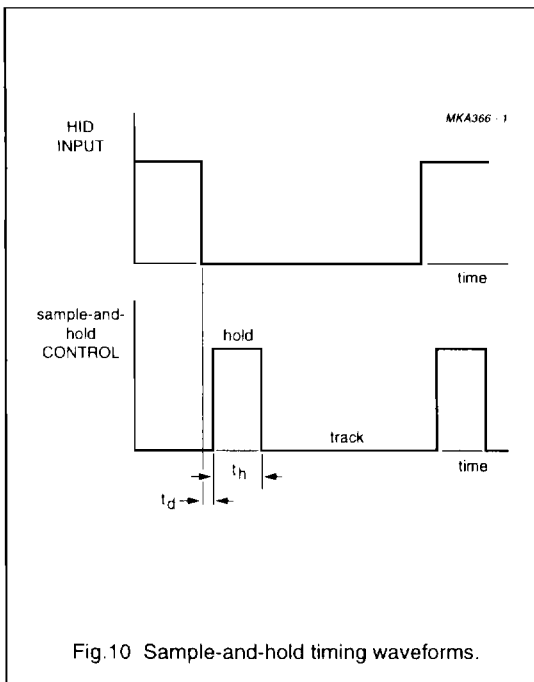

Fig.10 Sample-and-hold timing waveforms.

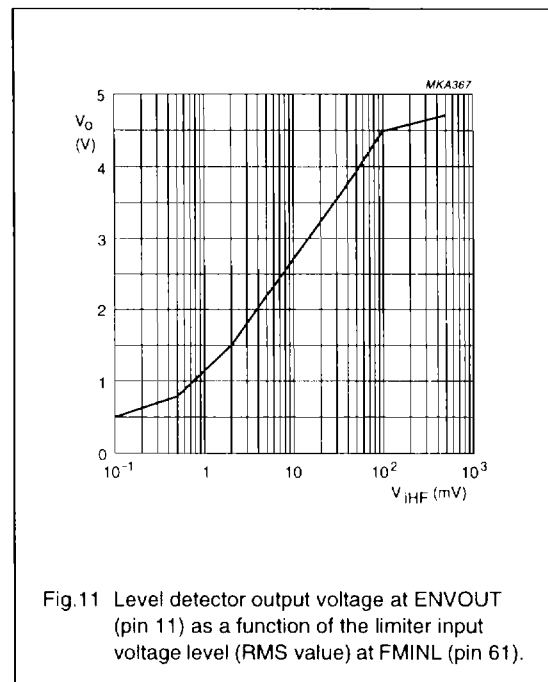

Fig.11 Level detector output voltage at ENVOUT (pin 11) as a function of the limiter input voltage level (RMS value) at FMINL (pin 61).

Audio FM processor for VHS hi-fi audio

TDA9610H

INTERNAL CIRCUITRY

SYMBOL	PIN	EQUIVALENT CIRCUIT	DESCRIPTION
AFINL	1		audio input for either audio clipper (record) or noise reduction (playback) of left channel
AFOUTL	2		audio output from either sample-and-hold (playback) or noise reduction (record and loop-through) of left channel
EXT2L	3		input selector for left channel
EXT1L	5		
CINL	7		
TUNL	9		

Audio FM processor for VHS hi-fi audio

TDA9610H

SYMBOL	PIN	EQUIVALENT CIRCUIT	DESCRIPTION
EXT2R	4	<p>MKA323 - 1</p>	input selector for right channel
EXT1R	6		
CINR	8		
TUNR	10		
ENVOUT	11	<p>MKA324 - 1</p>	level detector output; external capacitor required for filtering
MUTE	12	<p>MKA325 - 1</p>	mute timing; external capacitor required for timing playback mute
V _{DDD}	13		digital supply voltage (+5 V)

Audio FM processor for VHS hi-fi audio

TDA9610H

SYMBOL	PIN	EQUIVALENT CIRCUIT	DESCRIPTION
RAF	14		<p>override the I²C-bit RAF input or record/playback switch drive output for head amplifier control</p>
V _{SSD}	15		I ² C-bus digital ground
SDA	16		I ² C-bus data input
SCL	17		I ² C-bus clock input
XS	18		auxiliary switch; digital output controlled by I ² C-bit XS
V _{DDA1}	19		analog supply voltage (+12 V)
V _{DDH}	20		headphone supply voltage (+12 V)

Audio FM processor for VHS hi-fi audio

TDA9610H

SYMBOL	PIN	EQUIVALENT CIRCUIT	DESCRIPTION
V_{SSH}	21		headphone ground
HPOUTL	22		headphone drive output left
HPOUTR	23		headphone drive output right
RVAR	24		gain adjustment of noise reduction by means of a resistor to ground
RFIX	25		fixed bias current generation circuit by using an external 100 kΩ resistor to ground
i.c.	26		pin internally connected to die pad; preferably connected to ground

Audio FM processor for VHS hi-fi audio

TDA9610H

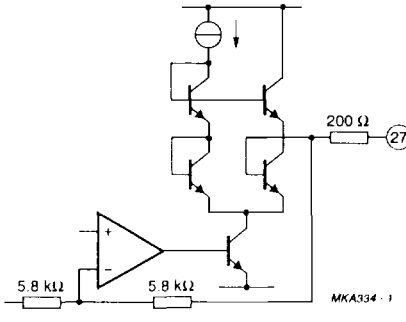
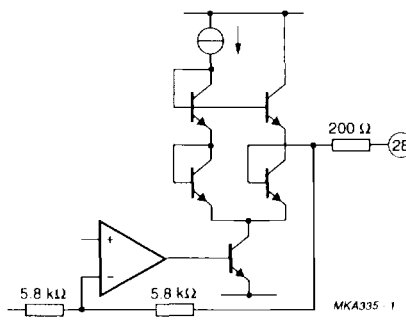
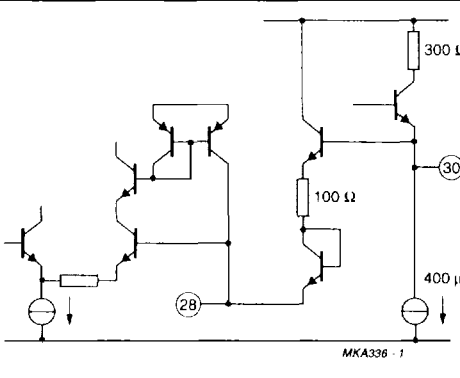
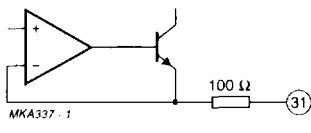
SYMBOL	PIN	EQUIVALENT CIRCUIT	DESCRIPTION
LINEL	27		line output left
LINER	28		line output right
MODAGC	29		RF modulator AGC time constant
MODOUT	30		RF modulator drive output
DCOUTL	31		VU meter drive output left

Audio FM processor for VHS hi-fi audio

TDA9610H

SYMBOL	PIN	EQUIVALENT CIRCUIT	DESCRIPTION
DCOUTR	32		VU meter drive output right
LININ	33		linear input
n.c.	34		not connected
DCFBL	35		DC feedback left
DCREFL	36		DC reference left
EMPHL	37		total emphasis left (20 to 240 μ s)
RECTL	38		rectifier DC decoupling left
DETL	39		attack/recovery timing left

Audio FM processor for VHS hi-fi audio

TDA9610H

SYMBOL	PIN	EQUIVALENT CIRCUIT	DESCRIPTION
V_{ref}	40		noise filtering of 3.8 V reference voltage; external capacitor required for filtering
V_{SSA1}	41		analog ground for LF circuits
DETR	42		attack/recovery timing right
RECTR	43		rectifier DC decoupling right
EMPHR	44		total emphasis right (20 to 240 μs)
DCREFR	45		DC reference right
DCFBR	46		DC feedback right

Audio FM processor for VHS hi-fi audio

TDA9610H

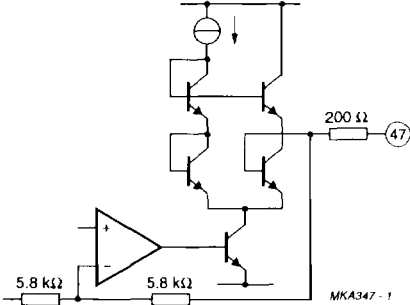
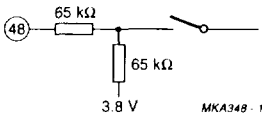
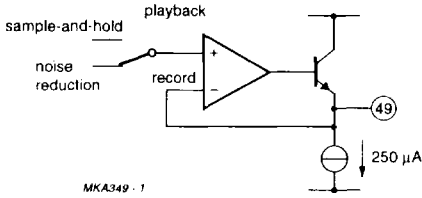
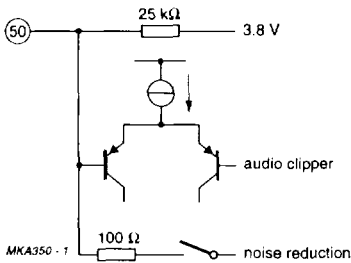
SYMBOL	PIN	EQUIVALENT CIRCUIT	DESCRIPTION
LINOUT	47		linear output
EXN1	48		EXN input (External Normal Input); mono input selectable to linear output
AFOUR	49		audio output from either sample-and-hold (playback) or noise reduction (record and loop-through) of right channel
AFINR	50		audio input for either audio clipper (record) or noise reduction (playback) of right channel

Audio FM processor for VHS hi-fi audio

TDA9610H

SYMBOL	PIN	EQUIVALENT CIRCUIT	DESCRIPTION
HID	51		Head Identification pulse input for sample-and-hold circuits
EXN2	52		EXN input (External Normal Input); mono input selectable to linear output
FADJR	53		frequency adjustment of right channel oscillator by means of a variable resistor
n.c.	54		not connected; preferably connected to ground
FMINR	55		1.7 or 1.8 MHz input for limiter
FMOUT	56		FM output
V _{DDA2}	57		analog supply voltage (+5 V)

Audio FM processor for VHS hi-fi audio

TDA9610H

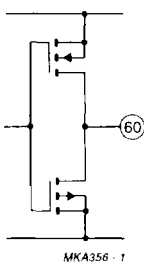
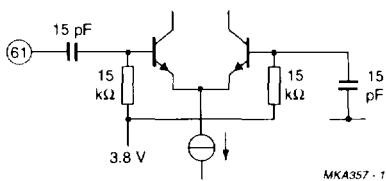
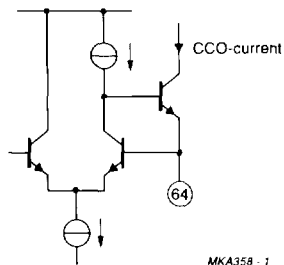
SYMBOL	PIN	EQUIVALENT CIRCUIT	DESCRIPTION
i.c.	58		pin internally connected to die pad; preferably connected to ground
V _{SSA2}	59		analog ground for HF circuits
NTSC	60	 <p style="text-align: center;">MKA356 - 1</p>	digital output controlled by I ² C-bit NTSC
FMINL	61	 <p style="text-align: center;">MKA357 - 1</p>	1.3 or 1.4 MHz input for limiter
n.c.	62		not connected; preferably connected to ground
n.c.	63		not connected; preferably connected to ground
FADJL	64	 <p style="text-align: center;">MKA358 - 1</p>	frequency adjustment of left channel oscillator by means of a variable resistor

Audio FM processor for VHS hi-fi audio

TDA9610H

TEST AND APPLICATION INFORMATION

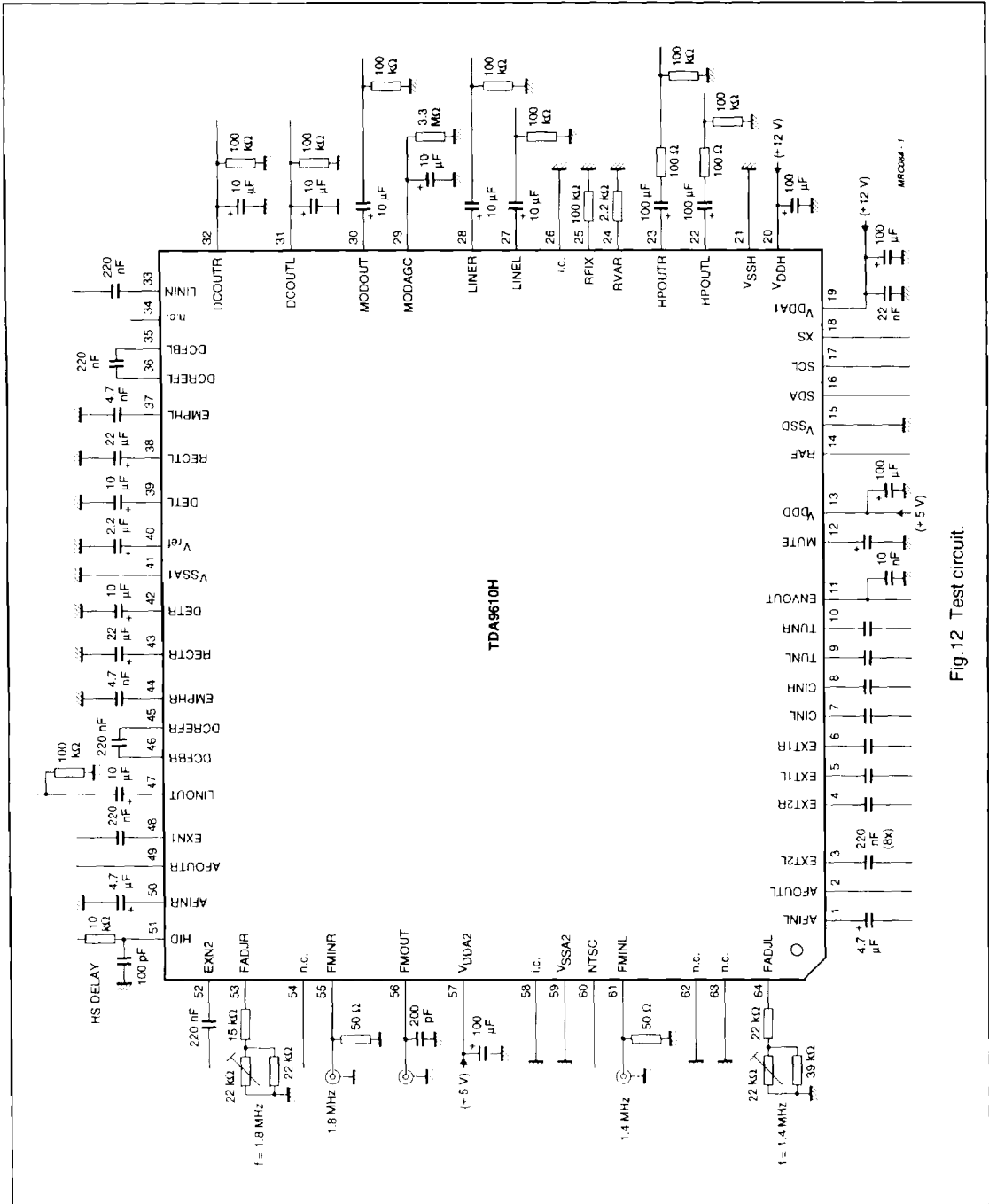

Fig.12 Test circuit.

Audio FM processor for VHS hi-fi audio

TDA9610H

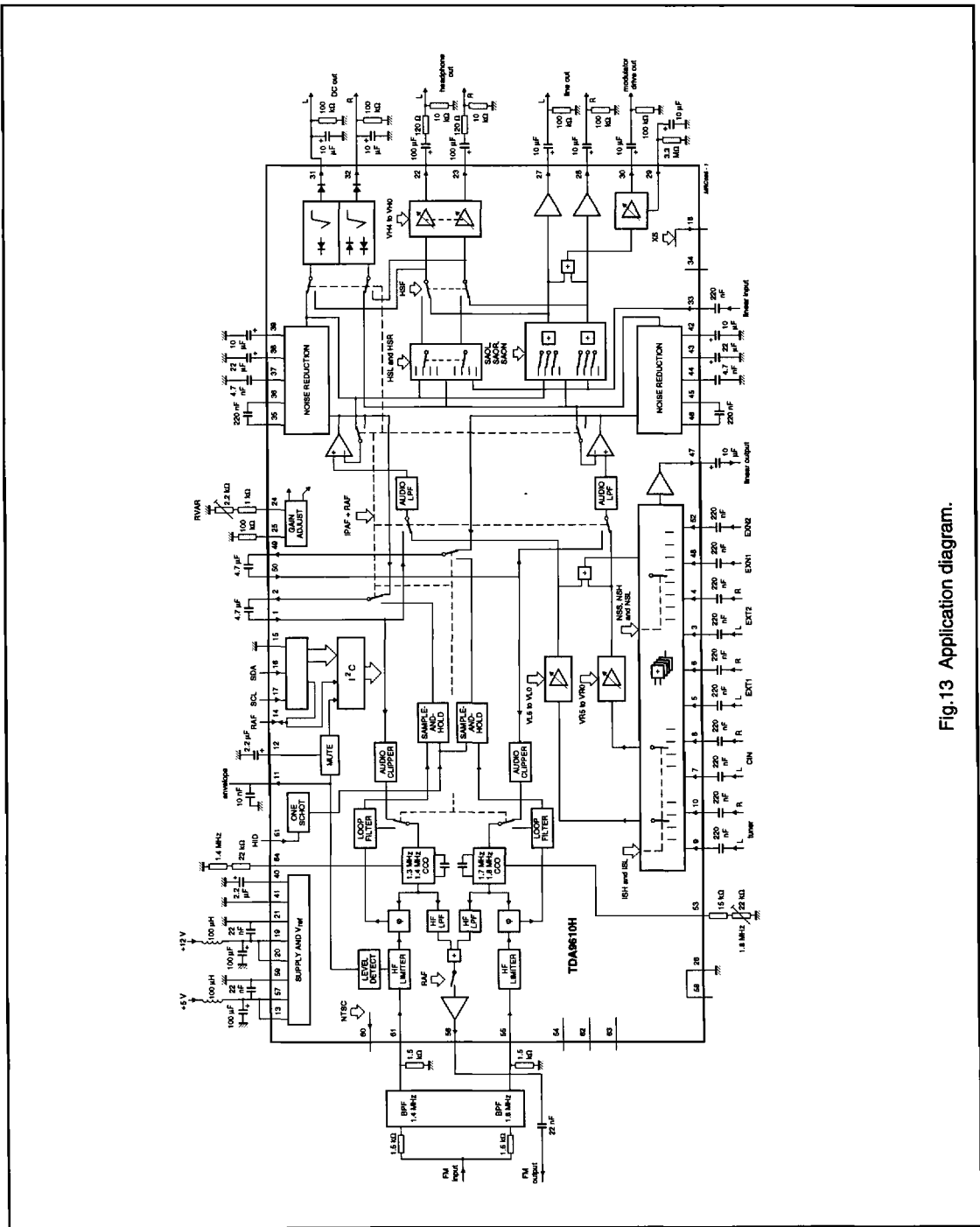

Fig.13 Application diagram.

Audio FM processor for VHS hi-fi audio

TDA9610H

Adjustment of VCO frequency

Set the TDA9610H in record mode (NTSC off), no audio input signal.

Measure the frequency at FMOUT (pin 56) with a frequency counter and use the VCO TEST modes (see Section "Function byte") to output only the channel of interest.

Adjust the VCO frequencies to 1.4 MHz \pm 10 kHz and 1.8 MHz \pm 10 kHz by means of the potentiometers at pin 64 (FADJL) and pin 53 (FADJR).

When NTSC is to be the main video standard, set NTSC on and adjust to 1.3 MHz and 1.7 MHz for optimum frequency accuracy.

Standard FM deviation and audio level

Reference levels of frequency deviation and audio output level are set by the resistor value at pin 24 (RVAR); simultaneous for left, right, playback and record. Typical resistor values can be calculated with equation:

$$R_{typ} = \frac{\left(\frac{\Delta f}{50 \text{ kHz}}\right)^2}{\left(\frac{A}{400 \text{ mV (RMS)}}\right)} \times 2.2 \text{ k}\Omega$$

Where:

Δf = reference FM deviation.

A = reference audio output level (1 kHz audio frequency).

If adjustment for overall tolerance is needed, R has to be made adjustable for the range $0.7R_{typ}$ to $1.4R_{typ}$.

Set the TDA9610H in playback. Use a HF test generator to make a carrier of 1.4 MHz with the desired modulation and input this signal at FMINL (pin 61) or before the band-pass filter and measure the audio output level at LINEL (pin 27).

Power-down mode

To lower the dissipation in a stand-by situation, the 12 V supply voltage at pin 19 (V_{DDA1}) and pin 20 (V_{DDH}) may be switched off, with pins 19 and 20 'floating'. No low-ohmic DC path to ground may be seen from pins 19 and 20, because this will drain extra current from the 5 V supply via these pins to ground.

Because of the fact that the I²C circuitry and the digital outputs RAF, NTSC and XS are supplied via the 5 V supply, no I²C settings will be lost and the output pins can still be used.

For instance, XS can be used to drive external mute transistors to mute the DC jump at the line outputs when switching the 12 V supply.

RAF I/O

The status of the I²C RAF bit is output at pin 14 (RAF = HIGH; record). This output can be used to switch the audio FM head amplifier to playback and record. If accurate fast switching of the TDA9610H is needed, this pin can also be used as input. Thereby overruling the I²C RAF bit. To make this possible the RAF output is current limited.

When using the RAF pin as output, no more than 35 μ A (LOW) and 185 μ A (HIGH) current may be drawn from this pin to assure the mode of the TDA9610H is not changed.

When using the RAF pin as input, the voltage source used must be capable of delivering at least 345 μ A (forced HIGH; >3.5 V) or sinking at least 65 μ A (forced LOW; <1.5 V).