



Analog, Mixed-Signal and Power Management

MC07XSF517

Triple 7.0 mOhm and Dual 17 mOhm High-Side Switch

Target Applications

- Low-voltage exterior lighting
- Low-voltage industrial lighting
- Low-voltage automation systems
- Halogen lamps
- Incandescent bulbs
- Light-emitting diodes (LEDs)
- HID xenon ballasts
- DC motors

Overview

The MC07XSF517 is the latest achievement in DC motors and lighting drivers. It belongs to an expanding family to control and diagnose various types of loads, such as incandescent lamps or light-emitting diodes (LEDs) with enhanced precision. It combines flexibility through daisy chainable SPI 5 MHz, extended digital and analog feedbacks, safety and robustness.

Output edge shaping helps to improve electromagnetic performance. To avoid shutting off the device upon inrush current, while still being able to closely track the load current, a dynamic overcurrent threshold profile is featured. Current of each channel can be sensed with a programmable sensing ratio. Whenever communication with the external microcontroller is lost, the device enters a Fail operation mode—but remains operational, controllable and protected.

This new generation of high-side switch products facilitates ECU design due to compatible MCU software and PCB footprints for each device variant.

This product is packaged in a Pb-free power-enhanced SOIC package with an exposed pad.

Simplified Application Drawing

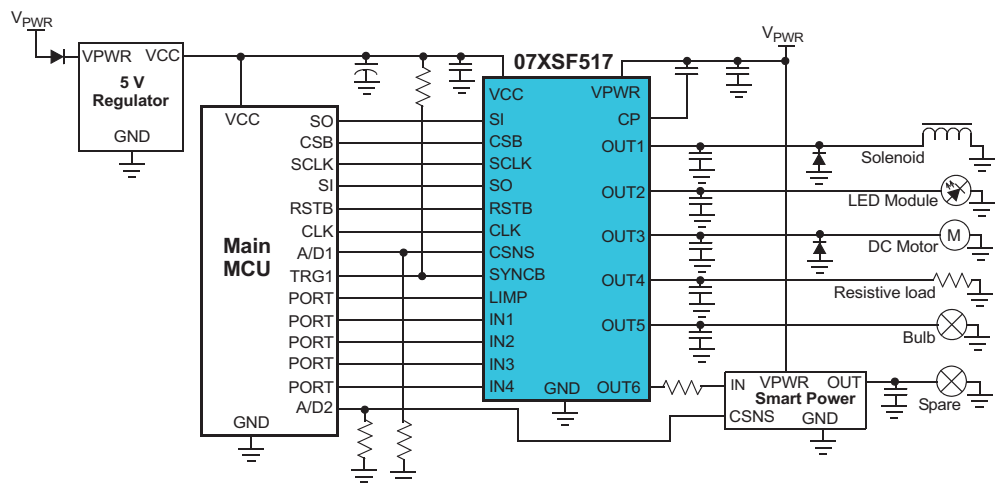

Freescal: A Leader in Analog Solutions

Expanding on more than 30 years of innovation, Freescale is a leading provider of high-performance products that use SMARTMOS technology combining digital, power and standard analog functions. Freescale supplies analog and power management ICs that are advancing the automotive, consumer, industrial and networking markets. Analog solutions interface with real-world signals to control and drive for complete embedded systems.

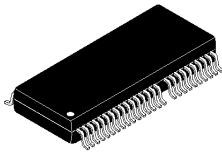

54-PIN SOICW-EP
98ASA00367D

Product Features and Benefits

Features	Function	Benefits
Scalable family	<ul style="list-style-type: none"> Compatible devices in terms of footprint and software Flexible load management from high current (HID, 65 W lamps) to LEDs while keeping a 100% diagnostic coverage 	<ul style="list-style-type: none"> Allows last-minute device choice in platforms for which the output load is not known or has to be flexible. Single hardware for multiple applications at a single engineering development cost.
SPI interface	<ul style="list-style-type: none"> 5.0 V 16-bit 5MHz SPI communication Daisy chainable SPI control Programming, output control and diagnostic reporting 	<ul style="list-style-type: none"> Enables daisy chaining without resistor between MCU and device for MCU I/O and number of discrete reduction. BOM cost saving.
Analog diagnostics	<ul style="list-style-type: none"> Accurate temperature (± 5.0 °C), supply voltage sensing Synchronous/asynchronous current sensing with advanced current mode 	<ul style="list-style-type: none"> Software simplification in case of many load management High-precision current sensing (down to 25 mA) with calibration procedure allowing diagnostic of both high-current loads or LEDs
Self-protected high-side switch	<ul style="list-style-type: none"> Triple 7.0 mΩ and dual 17 mΩ high-side switches Programmable dynamic threshold overcurrent protection and overtemperature protection 	<ul style="list-style-type: none"> 30% module size reduction and module quality longevity. Allows a low-power dissipation module design and very robust solution against repetitive overcurrent stress.
Limp mode	<ul style="list-style-type: none"> Protected output in fail-safe mode Direct input control with unlimited autorestart feature 	<ul style="list-style-type: none"> Safe secure system
PWM capability	<ul style="list-style-type: none"> Individually programmable internal/external PWM clock signals with prescaler per channel Selectable slew rate per output and multiphasing. 8-bit flexibility for duty cycle settings 	<ul style="list-style-type: none"> Software design simplicity for ppm reduction and software development time optimization. Optimized electromagnetic emission vs. switching power losses selection possible.
Reverse voltage protection	<ul style="list-style-type: none"> -16 V reverse polarity and ground disconnect protections 	<ul style="list-style-type: none"> Protected against any mishandling

Documentation

Freescal Document Number	Title	Description
MC07XSF517	Triple 7.0 m Ω and Dual 17 m Ω High-Side Switch	Data sheet
SG1002	Analog, Mixed-Signal and Power Management	Data sheet
SG200	Analog and Power Management Industrial Selector Guide	Selector guide

For more information, please visit freescale.com/analog

Freescal and the Freescal logo are trademarks of Freescal Semiconductor, Inc., Reg. U.S. Pat. & Tm. Off. SMARTMOS is a trademark of Freescal Semiconductor, Inc. All other product or service names are the property of their respective owners. © 2013 Freescal Semiconductor, Inc.

Document Number: MC07XSF517FS REV 1

