

2SK3511

Features

- Super low on-state resistance:
 $R_{DS(on)} = 12.5 \text{ m}\Omega \text{ MAX. (} V_{GS} = 10 \text{ V, } I_D = 42 \text{ A)}$
- Low C_{iss} : $C_{iss} = 5900 \text{ pF TYP.}$
- Built-in gate protection diode

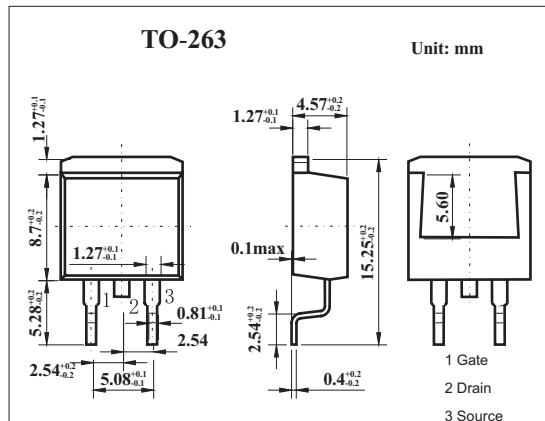

Absolute Maximum Ratings $T_a = 25^\circ\text{C}$

Parameter	Symbol	Rating	Unit
Drain to source voltage	V_{DS}	75	V
Gate to source voltage	V_{GS}	± 20	V
Drain current	I_D	± 83	A
	I_{dp}^*	± 260	A
Power dissipation	P_D	$T_C=25^\circ\text{C}$	100
		$T_A=25^\circ\text{C}$	1.5
Channel temperature	T_{ch}	150	$^\circ\text{C}$
Storage temperature	T_{stg}	-55 to +150	$^\circ\text{C}$

* $PW \leq 10 \mu\text{s}$, Duty Cycle $\leq 1\%$

Electrical Characteristics $T_a = 25^\circ\text{C}$

Parameter	Symbol	Test conditions	Min	Typ	Max	Unit
Drain cut-off current	I_{DSS}	$V_{DS}=75\text{V}, V_{GS}=0$			10	μA
Gate leakage current	I_{GSS}	$V_{GS} = \pm 20\text{V}, V_{DS}=0$			± 10	μA
Gate cutoff voltage	$V_{GS(off)}$	$V_{DS}=10\text{V}, I_D=1\text{mA}$	2.0	3.0	4.0	V
Forward transfer admittance	$ Y_{fs} $	$V_{DS}=10\text{V}, I_D=42\text{A}$	21	45		S
Drain to source on-state resistance	$R_{DS(on)}$	$V_{GS}=10\text{V}, I_D=42\text{A}$		9.5	12.5	$\text{m}\Omega$
Input capacitance	C_{iss}	$V_{DS}=10\text{V}, V_{GS}=0, f=1\text{MHz}$		5900		pF
Output capacitance	C_{oss}			810		pF
Reverse transfer capacitance	C_{rss}			400		pF
Turn-on delay time	t_{on}	$I_D=42\text{A}, V_{GS(on)}=10\text{V}, R_L=10\Omega, V_{DD}=38\text{V}$		30		ns
Rise time	t_r			21		ns
Turn-off delay time	t_{off}			72		ns
Fall time	t_f			12		ns
Total Gate Charge	Q_G	$I_D=83\text{A}, V_{DD}=60\text{V}, V_{GS}=10\text{V}$		100		nC
Gate to Source Charge	Q_{GS}			24		nC
Gate to Drain Charge	Q_{GD}			35		nC