

3.3 VOLT ZERO DELAY, LOW SKEW BUFFER

ICS2305

Description

The ICS2305 is a low phase noise, high-speed PLL based, low-skew zero delay buffer. Based on ICS' proprietary low jitter Phase Locked Loop (PLL) techniques, the device provides four low skew outputs at speeds up to 133 MHz at 3.3 V. The outputs can be generated from the PLL (for zero delay), or directly from the input (for testing), and can be set to tri-state mode or to stop at a low level. The PLL feedback is on-chip and is obtained from the CLKOUT pad.

The ICS2305 is available in two different versions. The ICS2305-1 is the base part. The ICS2305-1H is a high drive version with faster rise and fall times.

Features

- Clock outputs from 10 to 133 MHz
- Zero input-output delay
- Four low skew (<250 ps) outputs
- Device-to-device skew <700 ps
- Full CMOS outputs with 25 mA output drive capability at TTL levels
- 5 V tolerant CLKIN
- Tri-state mode for board-level testing
- Advanced, low power, sub-micron CMOS process
- Operating voltage of 3.3 V
- Industrial temperature range available
- Packaged in 8-pin SOIC
- Available in Pb (lead) free package

Block Diagram

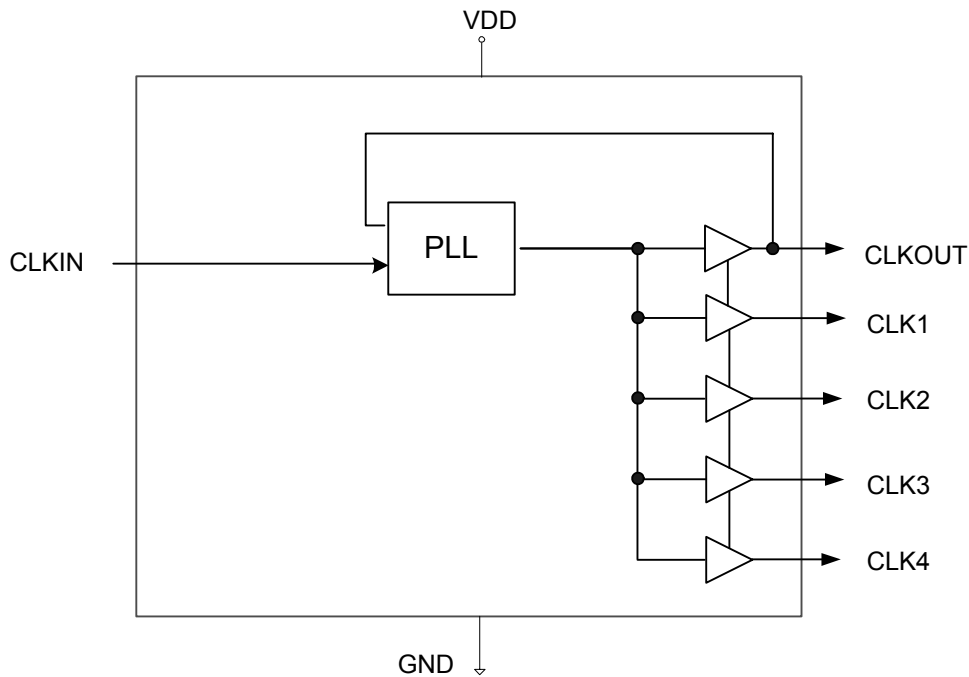

Pin Assignment

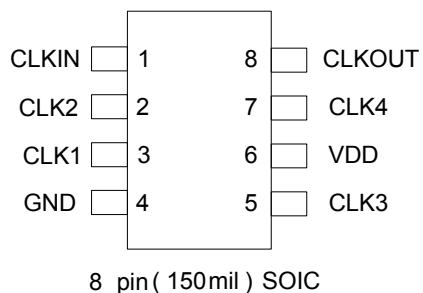

Pin Descriptions

Pin Number	Pin Name	Pin Type	Pin Description
1	CLKIN	Input	Clock input (5 V tolerant).
2	CLK2	Output	Buffered Clock output 2.
3	CLK1	Power	Buffered Clock output 1
4	GND	Power	Connect to ground.
5	CLK3	Output	Buffered Clock output 3
6	VDD	Power	Power supply. Connect to 3.3 V.
7	CLK4	Output	Buffered Clock output 4.
8	CLKOUT	Output	Buffered output. Internall feedback on this pin.

External Components

The ICS2305 requires a minimum number of external components for proper operation. Decoupling capacitors of 0.01 mF should be connected between VDD and GND on pins 4 and 5, and VDD and GND on pins 13 and 12, as close to the device as possible. A series termination resistor of 33Ω may be used to each clock output pin to reduce reflections.

Absolute Maximum Ratings

Stresses above the ratings listed below can cause permanent damage to the ICS2305. These ratings, which are standard values for ICS commercially rated parts, are stress ratings only. Functional operation of the device at these or any other conditions above those indicated in the operational sections of the specifications is not implied. Exposure to absolute maximum rating conditions for extended periods can affect product reliability. Electrical parameters are guaranteed only over the recommended operating temperature range.

Item	Rating
Supply Voltage, VDD	7 V
All Inputs and Outputs	-0.5 V to VDD+0.5 V
CLKIN and FBIN inputs	-0.5 V to 5.5 V
Electrostatic Discharge (HBM)	2000 V
Ambient Operating Temperature (Commercial)	0 to +70°C
Ambient Operating Temperature (Industrial)	-40 to +85°C
Storage Temperature	-65 to +150°C
Junction Temperature	150°C
Soldering Temperature	260°C

Recommended Operation Conditions

Parameter	Min.	Typ.	Max.	Units
Ambient Operating Temperature (Industrial)	-40		+85	°C
Ambient Operating Temperature (Commercial)	0		+70	°C
Power Supply Voltage (measured in respect to GND)	+3.0		+3.6	V

DC Electrical Characteristics

ICS2305M-XX, VDD = 3.3 V ±10%, Ambient Temperature -40 to +85°C(Industrial), (0-70°C Commercial)

Parameter	Symbol	Conditions	Min.	Typ.	Max.	Units
Operating Voltage	VDD		3.0		3.6	V
Input High Voltage	V _{IH}		2			V
Input Low Voltage	V _{IL}				0.8	V
Input Low Current	I _{IL}	V _{IN} = 0V			50	μA
Input High Current	I _{IH}	V _{IN} = VDD			100	μA
Output High Voltage	V _{OH}	I _{OH} = -12 mA	2.4			V
Output Low Voltage	V _{OL}	I _{OL} = 12 mA			0.4	V
Operating Supply Current	IDD	No Load			32	mA
Power Down Supply Current		CLKIN = 0, Note 1			12	μA
Short Circuit Current	I _{OS}	Each output		±50		mA
Input Capacitance	C _{IN}	CLKIN		5		pF

Note 1: When there is no clock signal present at CLKIN, the ICS2305 will enter power down mode. The PLL is stopped and the outputs are tri-state.

AC Electrical Characteristics

ICS2305M-1, VDD=3.3 V ±10%, Ambient temperature -40 to +85°C(Industrial), (0-70°C Commercial)

Parameter	Symbol	Conditions	Min.	Typ.	Max.	Units
Output Clock Frequency	f _{IN}	10 pF load	10		133	MHz
Output Clock Frequency		30 pF load	10		100	MHz
Output Rise Time	t _{OR}	0.8 to 2.0 V, outputs loaded			2.5	ns
Output Fall Time	t _{OF}	2.0 to 0.8 V, outputs loaded			2.5	ns
Output Clock Duty Cycle	t _{DC}	measured at 1.4V, F _{out} =66.67 MHz	40	50	60	%
Output Clock Duty Cycle	t _{DC}	measured at 1.4V, F _{out} =50 MHz	45	50	55	%
Device to Device Skew		rising edges at VDD/2			700	ps
Output to Output Skew		rising edges at VDD/2			250	ps
Input to Output Skew		rising edges at VDD/2			±350	ps
Cycle to Cycle Jitter		measured at 66.67M, outputs loaded			200	ps
PLL Lock Time		Note 2			1.0	ms

Note 2: With VDD at a steady rate and valid input at CLKIN.

ICS2305M-1H, VDD=3.3 V \pm 10%, Ambient temperature -40 to +85°C(Industrial), (0-70°C Commercial),

Parameter	Symbol	Conditions	Min.	Typ.	Max.	Units
Output Clock Frequency	f_{IN}	10 pF load	10		133	MHz
Output Clock Frequency		30 pF load	10		100	MHz
Output Rise Time	t_{OR}	0.8 to 2.0 V, outputs loaded			1.5	ns
Output Fall Time	t_{OF}	2.0 to 0.8 V, outputs loaded			1.5	ns
Output Clock Duty Cycle	t_{DC}	measured at 1.4V, Fout=66.67 MHz	40	50	60	%
Output Clock Duty Cycle	t_{DC}	measured at 1.4V, Fout=50 MHz	45	50	55	%
Device to Device Skew		rising edges at VDD/2			700	ps
Output to Output Skew		rising edges at VDD/2			250	ps
Input to Output Skew		rising edges at VDD/2			\pm 350	ps
Cycle to Cycle Jitter		measured at 66.67M, outputs loaded			200	ps
PLL Lock Time		Note 3			1.0	ms

Note 3: With VDD at a steady rate and valid input at CLKIN

Thermal Characteristics

Parameter	Symbol	Conditions	Min.	Typ.	Max.	Units
Thermal Resistance Junction to Ambient	θ_{JA}	Still air		120		$^{\circ}$ C/W
	θ_{JA}	1 m/s air flow		115		$^{\circ}$ C/W
	θ_{JA}	3 m/s air flow		105		$^{\circ}$ C/W
Thermal Resistance Junction to Case	θ_{JC}			58		$^{\circ}$ C/W

Package Outline and Package Dimensions (8-pin SOIC, 150 Mil. Narrow Body)

Package dimensions are kept current with JEDEC Publication No. 95

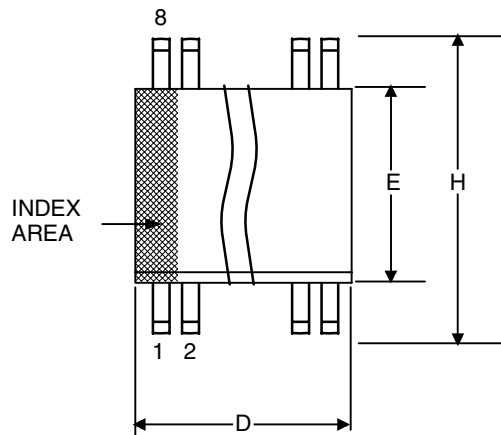

Symbol	Millimeters		Inches	
	Min	Max	Min	Max
A	1.35	1.75	.0532	.0688
A1	0.10	0.25	.0040	.0098
B	0.33	0.51	.013	.020
C	0.19	0.25	.0075	.0098
D	4.80	5.00	.1890	.1968
E	3.80	4.00	.1497	.1574
e	1.27 BASIC		0.050 BASIC	
H	5.80	6.20	.2284	.2440
h	0.25	0.50	.010	.020
L	0.40	1.27	.016	.050
α	0°	8°	0°	8°

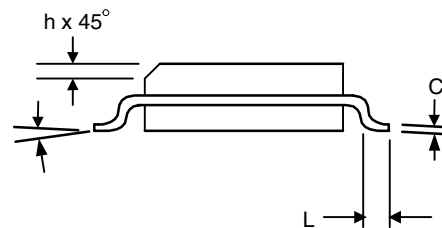
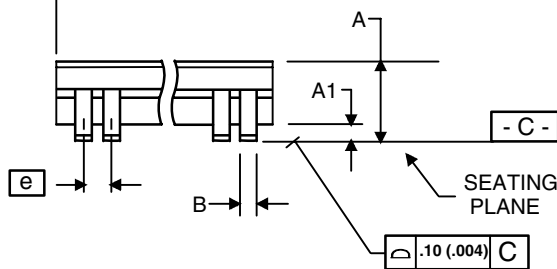

Ordering Information

Part / Order Number	Marking	Shipping Packaging	Package	Temperature
ICS2305MI-1	2305MI-1	Tubes	8-pin SOIC	-40 to +85° C
ICS2305MI-1T	2305MI-1	Tape and Reel	8-pin SOIC	-40 to +85° C
ICS2305MI-1H	2305MI1H	Tubes	8-pin SOIC	-40 to +85° C
ICS2305MI-1HT	2305MI1H	Tape and Reel	8-pin SOIC	-40 to +85° C
ICS2305MI-1LF	2305MI1L	Tubes	8-pin SOIC	-40 to +85° C
ICS2305MI-1LFT	2305MI1L	Tape and Reel	8-pin SOIC	-40 to +85° C
ICS2305MI-1HLF	2305I1HL	Tubes	8-pin SOIC	-40 to +85° C
ICS2305MI-1HLFT	2305I1HL	Tape and Reel	8-pin SOIC	-40 to +85° C
ICS2305M-1	2305M-1	Tubes	8-pin SOIC	0 to +70° C
ICS2305M-1T	2305M-1	Tape and Reel	8-pin SOIC	0 to +70° C
ICS2305M-1H	2305M-1H	Tubes	8-pin SOIC	0 to +70° C
ICS2305M-1HT	2305M-1H	Tape and Reel	8-pin SOIC	0 to +70° C
ICS2305M-1LF	2305M1LF	Tubes	8-pin SOIC	0 to +70° C
ICS2305M-1LFT	2305M1LF	Tape and Reel	8-pin SOIC	0 to +70° C
ICS2305M-1HLF	2305M1HL	Tubes	8-pin SOIC	0 to +70° C
ICS2305M-1HLFT	2305M1HL	Tape and Reel	8-pin SOIC	0 to +70° C

“LF” denotes Pb (lead free) package.

While the information presented herein has been checked for both accuracy and reliability, Integrated Circuit Systems (ICS) assumes no responsibility for either its use or for the infringement of any patents or other rights of third parties, which would result from its use. No other circuits, patents, or licenses are implied. This product is intended for use in normal commercial applications. Any other applications such as those requiring extended temperature range, high reliability, or other extraordinary environmental requirements are not recommended without additional processing by ICS. ICS reserves the right to change any circuitry or specifications without notice. ICS does not authorize or warrant any ICS product for use in life support devices or critical medical instruments.

Revision History

Rev.	Originator	Date	Description of Change
A	P. Griffith	12/01/04	New device/datasheet; Preliminary.
B	P. Griffith	12/27/04	Made corrections to IDD, IDDP, input capacitance, duty cycle and jitter specs/test conditions. Removed reference to table 2 in output clock frequency test conditions. Removed absolute and cycle-to-cycle jitter specs for 15 pF load. Added duty cycle spec for Fout=50 MHz. Release from Preliminary to Final.
C	P. Griffith	1/25/05	Made corrections to test conditions of output rise time, fall-time, duty cycle and cycle-to-cycle jitter.
D	J. Sarma	2/25/05	Added LF packing info.

Innovate with IDT and accelerate your future networks. Contact:

www.IDT.com

For Sales

800-345-7015
408-284-8200
Fax: 408-284-2775

For Tech Support

clockhelp@idt.com
408-284-8200

Corporate Headquarters

Integrated Device Technology, Inc.
6024 Silver Creek Valley Road
San Jose, CA 95138
United States
800 345 7015
+408 284 8200 (outside U.S.)

Asia Pacific and Japan

Integrated Device Technology
Singapore (1997) Pte. Ltd.
Reg. No. 199707558G
435 Orchard Road
#20-03 Wisma Atria
Singapore 238877
+65 6 887 5505

Europe

IDT Europe, Limited
Prime House
Barnett Wood Lane
Leatherhead, Surrey
United Kingdom KT22 7DE
+44 1372 363 339