

# Protection of Lithium Ion Batteries (three cells in series) Monolithic IC MM1293

## Outline

This IC provides protection for lithium ion batteries in the event of overcharging, overdischarging and overcurrents. When anomalies occur during charging or at other times and excessive voltages are applied, after a certain time has elapsed for each cell an external FET switch is turned off (overcharging detection); and in order to prevent overdischarge of the battery during discharge, when the voltage of individual batteries falls below a fixed voltage, an external FET switch is turned off (overdischarging detection), and the IC is put into low-consumption current mode. When large currents flow due to a short-circuit or other cause, an external MOS switch is turned off (overcurrent detection).

## 3-Cell Protection (Cs)

Rank	Overcharge detection voltage	Overcharge hysteresis voltage	Overdischarge detection voltage	Overdischarge resume voltage	Overcurrent detection voltage	At overcurrent detection	Overcurrent release conditions
A	4.35V±50mV	200mV typ.	2.35V typ.	3.05V typ.	150mV typ.	Pin 3 (DOHG pin) L→H	Load release 250kΩ or more
B	4.25V±50mV	↓	2.40V typ.	3.10V typ.	↓	↓	↓
C	Same as rank A	↓	Same as rank A		↓	Pin 4 (OL pin) H→L	↓
D	Same as rank B	↓	Same as rank B		↓	↓	↓
E	↓	none (several mV)	Same as rank B		↓	Pin 3 (DOHG pin) L→H	↓
F	4.10V±50mV	↓	2.35V typ.	3.00V typ.	↓	↓	↓
G	Same as rank A	200mV typ.	Same as rank A		↓	↓	Charging reset

## Features

- |   |                              |                               |
|---|------------------------------|-------------------------------|
| 1. Current consumption (overcharging)   | $V_{CELL} > V_{CELLU}$       | 125μA typ.                    |
| 2. Current consumption (normal operation)   | $V_{CELL} < V_{ALM}$         | 30μA typ.                     |
| 3. Current consumption (overdischarge)  | $V_{CELL} < V_{CELLS}$       | 0.1μA max.                    |
| 4. Overcharge detection voltage (−20 to +70°C)  | $V_{CELL} : L \rightarrow H$ | 4.25V±50mV/CELL               |
| 5. Overcharge hysteresis voltage  | $V_{CELL} : H \rightarrow L$ | $V_{CELLU} - 200mV/CELL$ typ. |
| 6. Overcharge sensing dead time   | $C = 0.1\mu F$               | 1.0S typ.                     |
| 7. Overcharge sensing operation voltage   | $V_{CELL} : L \rightarrow H$ | 4.10V±150mV/CELL              |
| 8. Overdischarge detection voltage  | $V_{CELL} : H \rightarrow L$ | 2.40V/CELL typ.               |
| 9. Overdischarge sensing dead time  | $C = 0.1\mu F$               | 1.0S typ.                     |
| 10. Overcurrent detection voltage   |                              | 0.15V typ.                    |
| 11. Overcharge and overdischarge voltages as well as the overcurrent detection voltage can be changed upon request. |                              |                               |

## Package

SSOP-16

## Applications

Lithium ion battery pack for notebook computers

Block Diagram

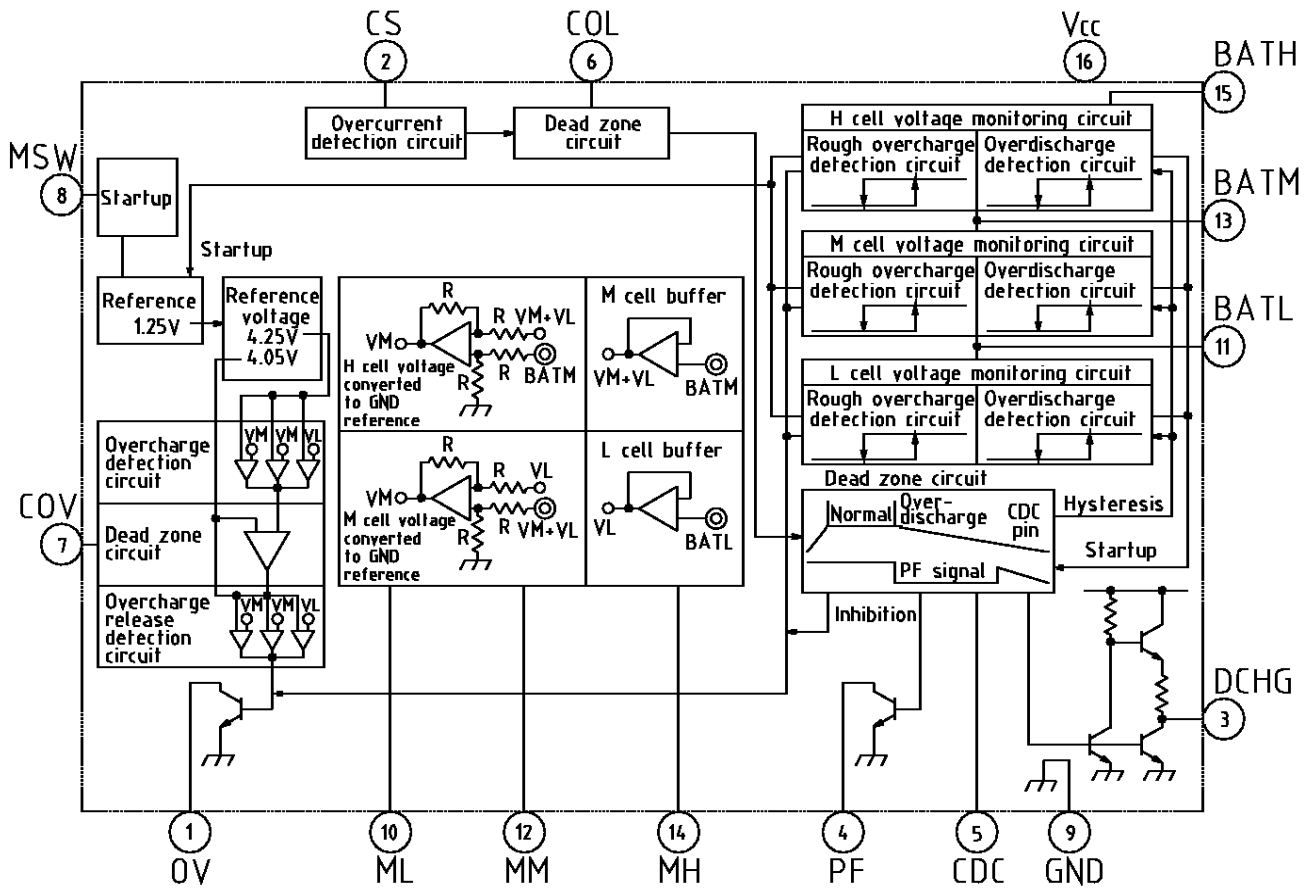

Pin Assignment

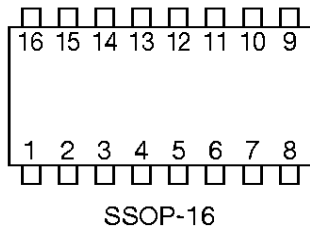

1	OV	9	GND
2	CS	10	ML
3	DCHG	11	BATL
4	PF	12	MM
5	CDC	13	BATM
6	COL	14	MH
7	COV	15	BATH
8	MSW	16	Vcc

**Pin Assignment**

Pin no.	Pin name	Input/output	Function
1	OV	Output	Overcharge detection output pin NPN transistor open collector output; normally high impedance, goes to L level on overdischarge
2	CS	Input	Overcurrent detection pin Monitors equivalent load current through source-drain voltage drop of discharge-controlling FET, and at or above the overcurrent detection voltage sets the DCHG pin to "H" and turns off the discharge-controlling FET. Following overcurrent detection, current is passed from this pin, and if the load is decreased, the overcurrent mode is canceled. Through this action there is a temporary consumption current (at the Vcc pin) of approx. 1 mA on resumption of discharge and detection of overdischarge. This function is disabled in overdischarge mode.
3	DCHG	Output	Pin driving the discharge-controlling FET (P-ch) Normally "L"; on overdischarge set to "H" Output pin for overdischarge detection signals
4	PF	Output	Overdischarge detection pin When the overdischarge detector detects overdischarge at the open collector output of the NPN transistor, this pin is turned on. A delay is provided by setting a dead time until discharge ends, so that by utilizing a reset or other signal from a CPU or some other controlling device, the equipment can be put into standby mode.
5	CDC	Input	Pin to set the dead time for overdischarge detection By connecting a capacitor between the CDC pin and GND, a dead time can be set. Pin to set the dead time for overcurrent detection
6	COL	Input	Pin to set the dead time for overcurrent detection By connecting a capacitor between the COL pin and GND, a dead time can be set. If NC, protection is triggered in a short amount of time; the dead time should be set according to the application.
7	COV	Input	Pin to set the dead time for overcharge detection By connecting a capacitor between the COV pin and GND, a dead time can be set.
8	MSW	Input	Pin to switch the cell voltage monitor on/off GND: monitor on, Vcc: monitor off The cell voltage monitor converts the different cell voltages to a GND-reference voltage and outputs it from the ML, MM and MH pins.
9	GND	Input	Ground pin
10	ML	Output	Monitor output pin for the L cell voltage
11	BATL	Input	Pin for input of L cell high-side voltage and M cell low-side voltage
12	MM	Output	Monitor output pin for the M cell voltage
13	BATM	Input	Pin for input of M cell high-side voltage and H cell low-side voltage
14	MH	Output	Monitor output pin for the H cell voltage
15	BATH	Input	Pin for input of H cell high-side voltage
16	Vcc	Input	Power supply input pin The same potential as the BATH pin should be input

**Absolute Maximum Ratings (Ta=25°C)**

Item	Symbol	Ratings	Units
Storage temperature	T <sub>STG</sub>	-40~+125	°C
Operating temperature	T <sub>OPR</sub>	-20~+70	°C
Charge voltage	V <sub>BAT</sub> max.	18	V
Power supply voltage	V <sub>CC</sub> max.	18	V
Voltage applied to OV pin	V <sub>OV</sub> max.	18	V
Allowable loss	P <sub>d</sub>	300	mW

**Recommended Operating Conditions**

Item	Symbol	Ratings	Units
Operating temperature	T <sub>OPR</sub>	-20~+70	°C
Operating voltage	V <sub>OPR</sub>	+2~+18	V

**Electrical Characteristics** (Except where noted otherwise, Ta=25°C, V<sub>CC</sub>=15V, V<sub>CELL</sub>=V<sub>BATH</sub>=V<sub>BATM</sub>=V<sub>BATL</sub>)

Item	Symbol	Measurement conditions	Min.	Typ.	Max.	Units
Consumption current (V <sub>CC</sub> pin) 1	I <sub>CC1</sub>	V <sub>CELL</sub> =4.4V		125	250	μA
Consumption current (V <sub>CC</sub> pin) 2	I <sub>CC2</sub>	V <sub>CELL</sub> =3.5V		30	60	μA
Consumption current (V <sub>CC</sub> pin) 3	I <sub>CC3</sub>	V <sub>CELL</sub> =2.2V			0.1	μA
Consumption current (BATH pin) 1	I <sub>BATH1</sub>	V <sub>CELL</sub> =4.4V		11	22	μA
Consumption current (BATH pin) 2	I <sub>BATH2</sub>	V <sub>CELL</sub> =3.5V		5	10	μA
Consumption current (BATH pin) 3	I <sub>BATH3</sub>	V <sub>CELL</sub> =2.2V		2	4	μA
BATM pin input current 1	I <sub>BATM</sub>	V <sub>CELL</sub> =3.5V			±300	nA
BATM pin input current 2	I <sub>BATMA</sub>	V <sub>CELL</sub> =4.4V	-0.6	-0.3	0	μA
BATL pin input current 1	I <sub>BATL</sub>	V <sub>CELL</sub> =3.5V			±300	nA
BATL pin input current 2	I <sub>BATLA</sub>	V <sub>CELL</sub> =4.4V	-0.6	-0.3	0	μA
Overcharge detection voltage	V <sub>CELLU</sub>	Ta=-20~+70°C, V <sub>CELL</sub> : 3.7V→4.5V	4.20	4.25	4.30	V
Overcharge detection release voltage	V <sub>CELLO</sub>	V <sub>CELL</sub> : 4.5V→3.7V	V <sub>CELLU</sub> -260mV	V <sub>CELLU</sub> -200mV	V <sub>CELLU</sub> -140mV	V
Overcharge sensing dead time	t <sub>OV</sub>	C <sub>OV</sub> =0.1μF	0.5	1.0	1.5	S
Overcharge sensing operation voltage	V <sub>ALM</sub>	V <sub>CELL</sub> : 3.5V→4.4V	3.95	4.10	4.25	V
Overdischarge sensing hysteresis voltage	ΔV <sub>ALM</sub>	V <sub>CELL</sub> : 4.4V→3.5V	120	200	300	mV
Overdischarge detection voltage	V <sub>CELLS</sub>	V <sub>CELL</sub> : 3.5V→2.0V	2.30	2.40	2.50	V
Discharge resume voltage	V <sub>CELLD</sub>	V <sub>CELL</sub> : 2.0V→3.5V	2.95	3.10	3.25	V
Overdischarge sensing hysteresis voltage	ΔV <sub>CsD</sub>	V <sub>CELLD</sub> -V <sub>CELLS</sub>	490	700	910	mV
Overdischarge sensing dead time	t <sub>DcD1</sub>	C <sub>DcD</sub> =0.1μF	0.5	1.0	1.5	S
Overdischarge reset dead time	t <sub>DcD2</sub>	C <sub>DcD</sub> =0.1μF, V <sub>Cs</sub> =V <sub>CC</sub> +0.3V		7		mS
Overcurrent detection voltage	V <sub>OC</sub>	V <sub>CC</sub> -V <sub>Cs</sub> , D <sub>CHG</sub>	0.135	0.150	0.165	V
Overcurrent sensing dead time	t <sub>COL1</sub>	C <sub>COL</sub> =0.001μF, D <sub>CHG</sub>	5	10	15	mS
Overcurrent reset dead time	t <sub>COL2</sub>	C <sub>COL</sub> =0.001μF, D <sub>CHG</sub>	5	10	15	mS
Overcurrent sensing delay time	t <sub>COL3</sub>	C <sub>COL</sub> =0, D <sub>CHG</sub>		150		μS
Overcurrent reset delay time	t <sub>COL4</sub>	C <sub>COL</sub> =0, D <sub>CHG</sub>		150		μS
Overcurrent protection release			Open-load condition 250kΩ			
DCHG pin source current	I <sub>SO</sub> D <sub>CH</sub>	V <sub>CELL</sub> < V <sub>CELLS</sub> , SW1 : A, V <sub>DCHG</sub> =V <sub>CC</sub> -1.8V	20			μA
DCHG pin sync current	I <sub>SI</sub> D <sub>CH</sub>	V <sub>CELL</sub> > V <sub>CELLS</sub> , SW1 : A, V <sub>DCHG</sub> =0.8V	20			μA
DCHG pin output voltage H	V <sub>TH</sub> D <sub>CH</sub>	V <sub>CC</sub> -V <sub>DCHG</sub> , I <sub>SO</sub> =20μA, SW1 : B			1.8	V
DCHG pin output voltage L	V <sub>TH</sub> D <sub>CL</sub>	V <sub>DCHG</sub> -GND, I <sub>SI</sub> =-20μA, SW1 : B			0.8	V
OV pin sync current	I <sub>SI</sub> O <sub>V</sub>	V <sub>OV</sub> =0.4V, Ta=-20~+70°C	0.2			mA
PF pin sync current	I <sub>SI</sub> P <sub>F</sub>	V <sub>PF</sub> =0.4V, Ta=-20~+70°C	10			μA

**Timing Chart**

**Overcharge**

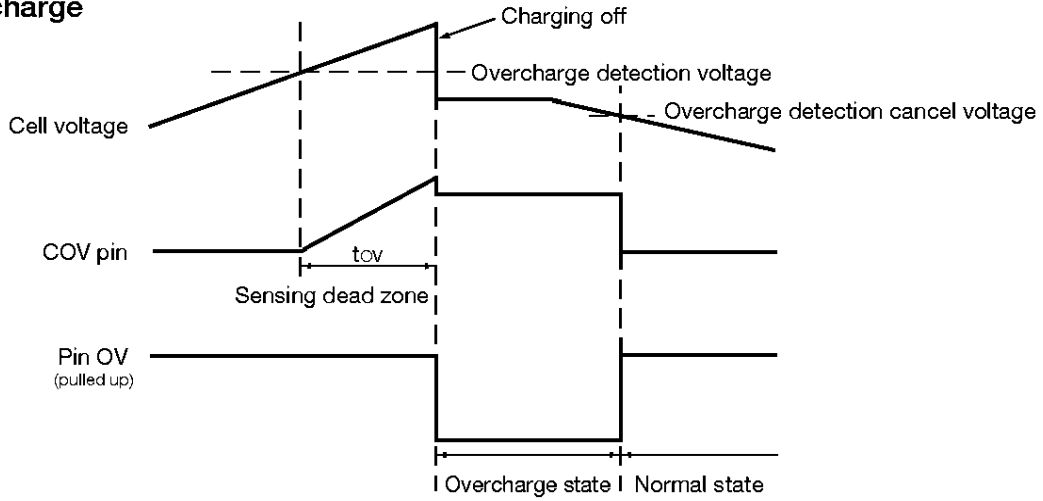

**Overdischarge**

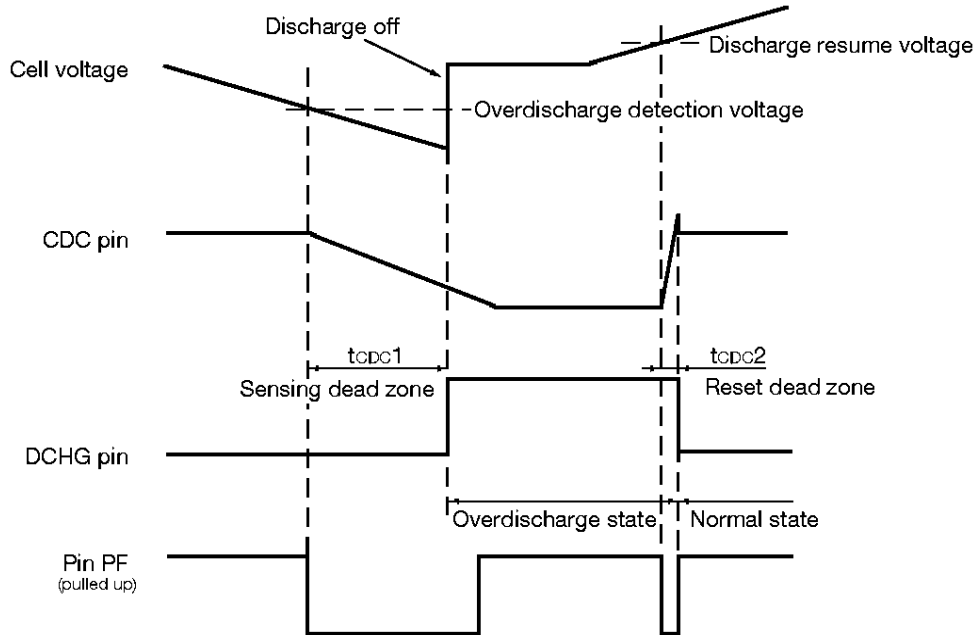

**Overcurrent**

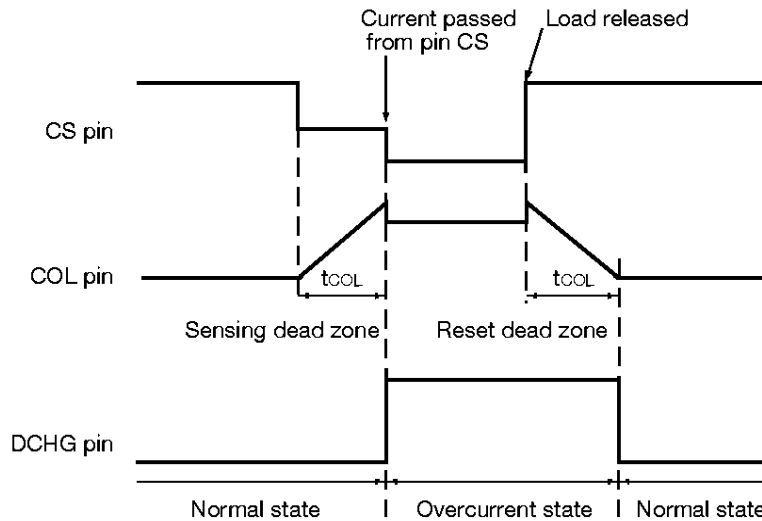

Application circuit

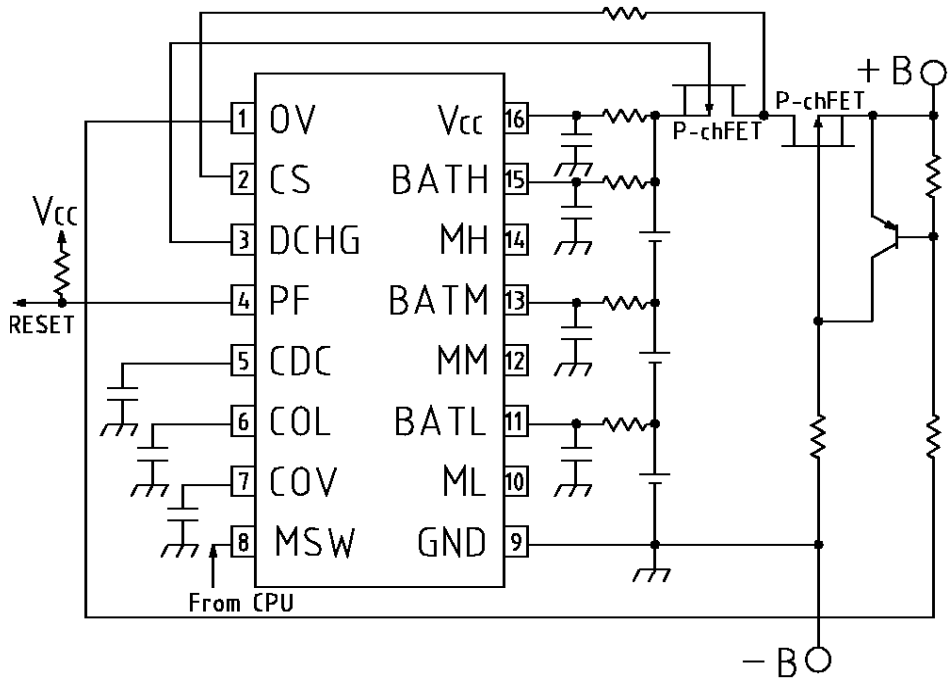

Characteristics

- Overcharge, overdischarge sensing dead time
- Overcurrent dead time

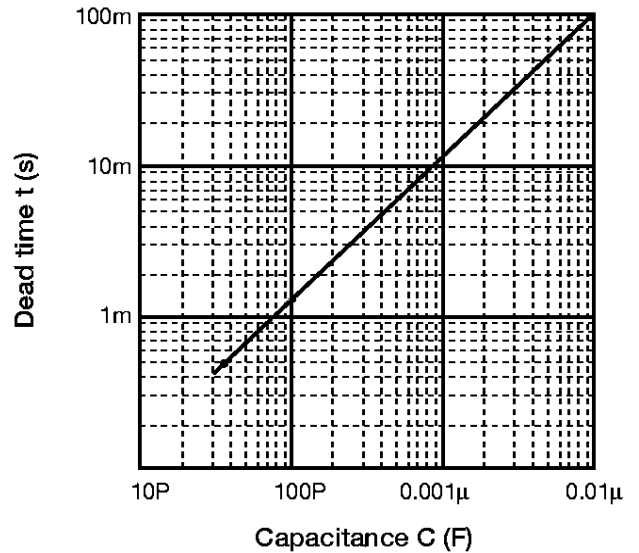
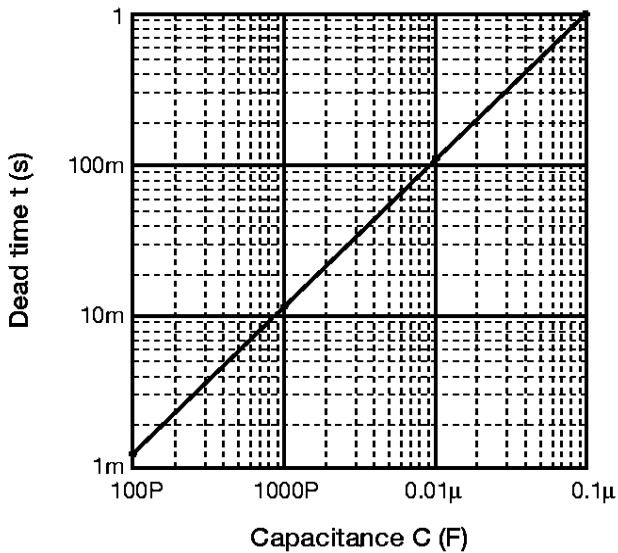

Note : The above characteristics are representative and are not guaranteed.