

APPLICATION MANUAL

LDO REGULATOR WITH ON/OFF SWITCH TK113xxCM

CONTENTS

1 . DESCRIPTION	2
2 . FEATURES	2
3 . APPLICATIONS	2
4 . PIN CONFIGURATION	2
5 . BLOCK DIAGRAM	2
6 . ORDERING INFORMATION	3
7 . ABSOLUTE MAXIMUM RATINGS	3
8 . ELECTRICAL CHARACTERISTICS	4
9 . TEST CIRCUIT	8
10 . APPLICATION EXAMPLE	8
11 . TYPICAL CHARACTERISTICS	9
12 . PIN DESCRIPTION	23
13 . APPLICATIONS INFORMATION	24
14 . NOTES	31
15 . OFFICES	31



LDO REGULATOR WITH ON/OFF SWITCH TK113xxCM

1. DESCRIPTION

The TK113xxC series of low dropout (LDO) voltage regulators are designed for use in battery-powered equipment, portable communication devices or RF modules requiring a thermal enhanced SOT23L-6 package. The power dissipation rating is 600mW.

Features include an operating voltage range of +1.8V to +14V and an output voltage range of 1.5V to 10.0V in 0.1V steps. The maximum continuous current power rating is 380mA. The load current is internally monitored and the device will shut down in the attendance of a short circuit, over-current condition at the output or a junction temperature exceeds 150°C.

An internal PNP pass transistor is used to achieve a typical low dropout voltage of 105mV (typ.) at 100mA load current and a standby current of typically 0.1µA at no load.. An external capacitor can be connected to the noise bypass pin to lower the output noise level to 45µVrms. This device is stable with low ESR ceramic capacitors.

2. FEATURES

- Active Low (Reference : Vin) On/Off Control
- Very Good Stability : Ceramic capacitor can be used.
: $CL \geq 0.01\mu F$ at $V_{out} \geq 2.5V$
- High Precision Output Voltage ($\pm 2\%$ or $\pm 60mV$)
- Excellent Ripple Rejection Ratio: -80dB at 1kHz
- Output Current : 300mA (peak 480mA)
- Very Low Dropout Voltage : 105mV at $I_{out} = 100mA$
- Wide Operating Voltage Range : 1.8V~14.5V
- Very Low Noise with Noise Bypass pin
- Short Circuit Protection (Over Current Protection)
- Internal Thermal Shutdown (Over Heat Protection)
- Reverse Bias Protection

3. APPLICATIONS

- Any Electronic Equipment
- Battery Powered Systems
- Mobile Communication

4. PIN CONFIGURATION

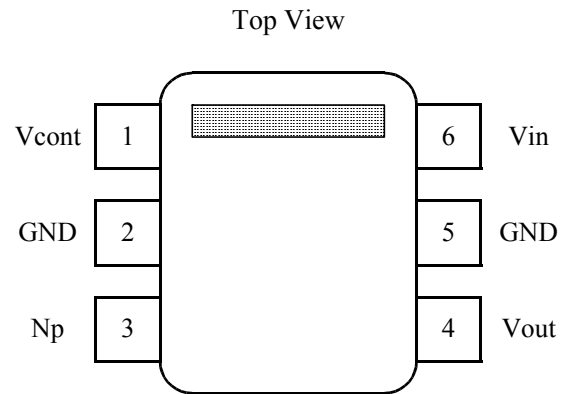

*2pin,5pin are connected in the IC.

5. BLOCK DIAGRAM

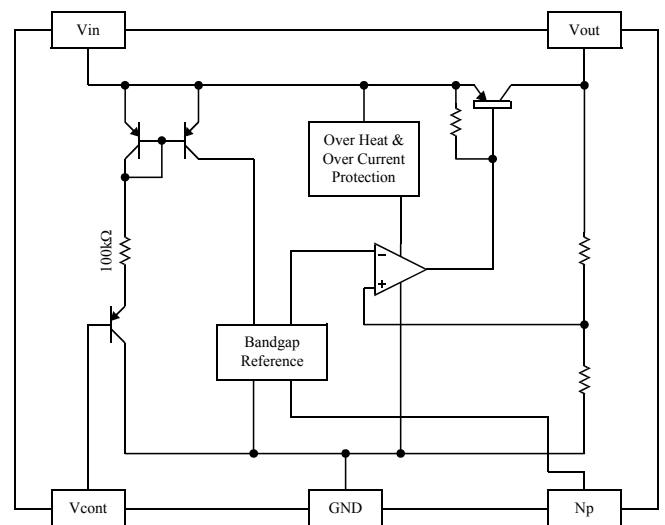

6. ORDERING INFORMATION

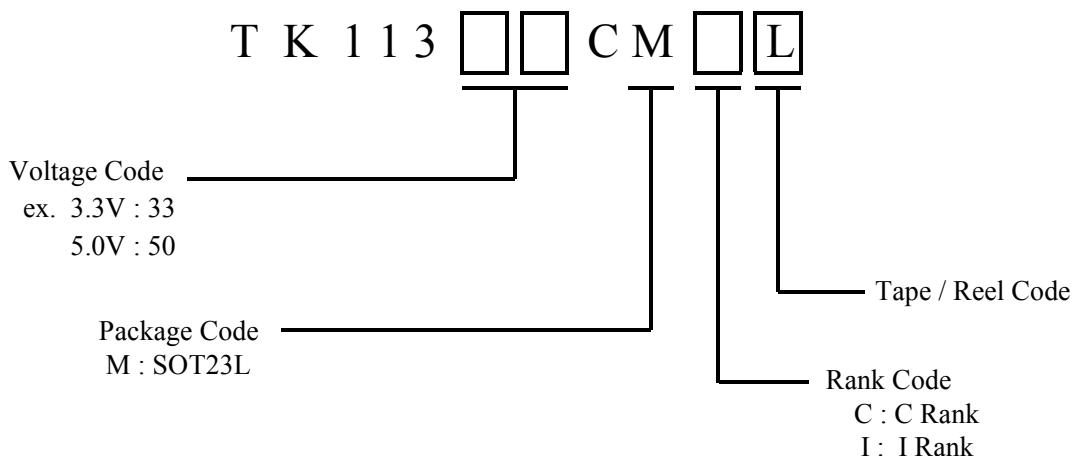

TK11320CM	TK11321CM	TK11322CM	TK11325CM	TK11326CM
TK11327CM	TK11328CM	TK11329CM	TK11330CM	TK11331CM
TK11332CM	TK11333CM	TK11335CM	TK11338CM	TK11340CM
TK11345CM	TK11347CM	TK11348CM	TK11350CM	TK11355CM
TK11360CM	TK11380CM			

*Please contact your authorized TOKO representatives for voltage availability.
If you need a voltage other than the value listed in the above table, please contact TOKO.

7. ABSOLUTE MAXIMUM RATINGS

Ta=25°C

Parameter	Symbol	Rating	Units	Conditions
Absolute Maximum Ratings				
Supply Voltage	V _{CCMAX}	-0.4 ~ 16	V	
Reverse Bias	V _{revMAX}	-0.4 ~ 6	V	V _{out} ≤ 2.0V
		-0.4 ~ 12	V	V _{out} ≥ 2.1V
Np pin Voltage	V _{npMAX}	-0.4 ~ 5	V	
Control pin Voltage	V _{contMAX}	-0.4 ~ 16	V	
Storage Temperature Range	T _{stg}	-55 ~ 150	°C	
Power Dissipation	P _D	600 when mounted on PCB	mW	Internal Limited T _j =150°C *
Operating Condition				
Operating Temperature Range	T _{OP}	-40 ~ 85	°C	
Operating Voltage Range	V _{OP}	1.8 ~ 14.5	V	T _{OP} = -30 ~ 80 °C
		2.1 ~ 14.5	V	T _{OP} = -40 ~ 85 °C
Short Circuit Current	I _{short}	500	mA	

* P_D must be decreased at rate of 4.8mW/°C for operation above 25°C.
The maximum ratings are the absolute limitation values with the possibility of the IC breakage.
When the operation exceeds this standard, quality can not be guaranteed.

8. ELECTRICAL CHARACTERISTICS

8-1. C Rank (TK113xxCMC)

The operation between -40 ~ 85°C is guaranteed with normal test. The parameter with limit value will be guaranteed with test when manufacturing or SQC(Statistical Quality Control) technique.

$$V_{in}=V_{outTYP}+1V, V_{cont}=V_{in}-1.8V, T_a=25^{\circ}C$$

Parameter	Symbol	Value			Units	Conditions
		MIN	TYP	MAX		
Output Voltage	Vout	Refer to TABLE 1			V	Iout = 5mA
Line Regulation	LinReg		0.0	6.0	mV	$\Delta V_{in} = 5V$
Load Regulation	LoaReg	Refer to TABLE 1			mV	Iout = 5mA ~ 100mA
		Refer to TABLE 1			mV	Iout = 5mA ~ 200mA
		Refer to TABLE 1			mV	Iout = 5mA ~ 300mA
Dropout Voltage *1	Vdrop		105	170	mV	Iout = 100mA
			170	270	mV	Iout = 200mA
			235	370	mV	Iout = 270mA (2.1V ≤ Vout ≤ 2.3V)
			235	370	mV	Iout = 300mA (Vout ≥ 2.4V)
Maximum Output Current *2	Iout_MAX	380	480		mA	When (Vout_TYP×0.9)
Supply Current	Iq		80	136	μA	Iout = 0mA
Standby Current	Istandby		0.0	0.1	μA	Vcont = Vin
Quiescent Current	Ignd		1.8	3.0	mA	Iout = 100mA
Control Terminal *3						
Control Current	Icont		1.0	5.0	μA	Vcont = Vin -1.8V
Control Voltage	Vcont	Vin-1.8			V	Vout ON state (Reference :Vin)
				Vin-0.6	V	Vout OFF state (Reference :Vin)
Reference Value						
Np Terminal Voltage	Vnp		1.28		V	
Output Voltage / Temp.	Vo/Ta		35		ppm /°C	
Output Noise Voltage (TK11330CM)	Vno		45		μVrms	CL=1.0μF, Cnp=0.01μF Iout=30mA
Ripple Rejection (TK11330CM)	R.R		80		dB	CL=1.0μF, Cnp=0.01μF Iout=10mA, 1kHz
Rise Time (TK11330CM)	tr		100		μs	CL=1.0μF, Cnp=0.01μF Vcont : Pulse Wave (100Hz) Vcont ON → Vout×95% point

*1: The minimum operating Voltage for Vin can be 1.8 V. Also, the minimum voltage required for Vin is Vin = Vdrop + Vout . As a result, operating at Vout = 2.0 V at the minimum operating voltage is not preferred.

*2: The maximum output current is limited by power dissipation.

*3: The input current decreases to the pA level by connecting the control terminal to GND (Off state).

General Note : Parameters with only typical values are just reference. (Not guaranteed)

General Note : It is possible to decrease the output noise voltage by connecting a capacitor with the noise bypass pin (Np). The noise level is dependent on the capacitance and capacitor characteristic.

TABLE 1

Part Number	Output Voltage			Load Regulation					
				Iout = 100mA		Iout = 200mA		Iout = 300mA	
	MIN	TYP	MAX	TYP	MAX	TYP	MAX	TYP	MAX
	V	V	V	mV	mV	mV	mV	mV	mV
TK11320CMC	1.940	2.000	2.060	11	25	23	53	37	85
TK11321CMC	2.040	2.100	2.160	11	26	23	53	38	86
TK11322CMC	2.140	2.200	2.260	12	26	24	54	38	88
TK11325CMC	2.440	2.500	2.560	12	27	24	55	40	91
TK11326CMC	2.540	2.600	2.660	12	27	25	56	40	92
TK11327CMC	2.640	2.700	2.760	12	27	25	56	41	93
TK11328CMC	2.740	2.800	2.860	12	27	25	57	41	95
TK11329CMC	2.840	2.900	2.960	12	27	25	58	42	96
TK11330CMC	2.940	3.000	3.060	12	28	26	58	42	97
TK11331CMC	3.038	3.100	3.162	12	28	26	59	43	98
TK11332CMC	3.136	3.200	3.264	12	28	26	59	44	99
TK11333CMC	3.234	3.300	3.366	13	28	26	60	44	101
TK11335CMC	3.430	3.500	3.570	13	29	27	61	45	103
TK11338CMC	3.724	3.800	3.876	13	29	28	63	47	107
TK11340CMC	3.920	4.000	4.080	13	30	28	64	48	109
TK11345CMC	4.410	4.500	4.590	14	31	29	67	50	115
TK11347CMC	4.606	4.700	4.794	14	31	30	68	51	117
TK11348CMC	4.704	4.800	4.896	14	32	30	68	52	118
TK11350CMC	4.900	5.000	5.100	14	32	31	70	53	121
TK11355CMC	5.390	5.500	5.610	15	33	32	72	55	127
TK11360CMC	5.880	6.000	6.120	15	34	33	75	58	133
TK11380CMC	7.840	8.000	8.160	17	39	38	87	68	156

Notice.

Please contact your authorized TOKO representative for voltage availability.
 If you need a voltage other than the value listed in the above table, please contact TOKO.

8-2. I Rank (TK113xxCMI)

The operation between -40 ~ 85°C is guaranteed with normal test. The parameter with limit value will be guaranteed with test when manufacturing or SQC(Statistical Quality Control) technique.

$$V_{in}=V_{outTYP}+1V, V_{cont}=V_{in}-2.0V, -T_a=-40 \sim 85^{\circ}C$$

Parameter	Symbol	Value			Units	Conditions
		MIN	TYP	MAX		
Output Voltage	Vout	Refer to TABLE 2			V	Iout = 5mA
Line Regulation	LinReg		0.0	8.0	mV	$\Delta V_{in} = 5V$
Load Regulation	LoaReg	Refer to TABLE 2			mV	Iout = 5mA ~ 100mA
		Refer to TABLE 2			mV	Iout = 5mA ~ 200mA
		Refer to TABLE 2			mV	Iout = 5mA ~ 300mA
Dropout Voltage *1	Vdrop		105	200	mV	Iout = 100mA (Vout ≥ 2.2V)
			170	320	mV	Iout = 200mA (Vout ≥ 2.2V)
			235	440	mV	Iout = 300mA (Vout ≥ 2.4V)
Maximum Output Current *2	IoutMAX	340	480		mA	When (VoutTYP×0.9)
Supply Current	Iq		80	144	μA	Iout = 0mA
Standby Current	Istandby		0.0	0.5	μA	Vcont = Vin
Quiescent Current	Ignd		1.8	3.6	mA	Iout = 100mA
Control Terminal *3						
Control Current	Icont		1.0	10	μA	Vcont = Vin - 2.0V
Control Voltage	Vcont	Vin-2.0			V	Vout ON state (Reference :Vin)
				Vin-0.4	V	Vout OFF state (Reference :Vin)
Reference Value						
Np Terminal Voltage	Vnp		1.28		V	
Output Voltage / Temp.	Vo/Ta		35		ppm /°C	
Output Noise Voltage (TK11330CM)	Vno		45		μVrms	CL=1.0μF, Cnp=0.01μF Iout=30mA
Ripple Rejection (TK11330CM)	R.R		80		dB	CL=1.0μF, Cnp=0.01μF Iout=10mA, 1kHz
Rise Time (TK11330CM)	tr		100		μs	CL=1.0μF, Cnp=0.01μF Vcont : Pulse Wave (100Hz) Vcont ON → Vout×95% point

*1: The minimum operating Voltage for Vin can be 2.1 V. Also, the minimum voltage required for Vin is Vin = V drop + Vout . As a result, operating at Vout _ 2.0 V at the minimum operating voltage is not preferred.

*2: The maximum output current is limited by power dissipation.

*3: The input current decreases to the pA level by connecting the control terminal to GND (Off state).

General Note : Parameters with only typical values are just reference. (Not guaranteed)

General Note : It is possible to decrease the output noise voltage by connecting a capacitor with the noise bypass pin (Np). The noise level is depended on the capacitance and capacitor characteristic.

TABLE 2

Part Number	Output Voltage			Load Regulation					
				Iout = 100mA		Iout = 200mA		Iout = 300mA	
	MIN	TYP	MAX	TYP	MAX	TYP	MAX	TYP	MAX
	V	V	V	mV	mV	mV	mV	mV	mV
TK11320CMI	1.900	2.000	2.100	11	30	23	65	37	122
TK11321CMI	2.000	2.100	2.200	11	31	23	65	38	124
TK11322CMI	2.100	2.200	2.300	12	31	24	66	38	126
TK11325CMI	2.400	2.500	2.600	12	31	24	68	40	131
TK11326CMI	2.500	2.600	2.700	12	32	25	69	40	133
TK11327CMI	2.600	2.700	2.800	12	32	25	70	41	135
TK11328CMI	2.700	2.800	2.900	12	32	25	70	41	137
TK11329CMI	2.800	2.900	3.000	12	32	25	71	42	139
TK11330CMI	2.900	3.000	3.100	12	33	26	72	42	141
TK11331CMI	3.000	3.100	3.200	12	33	26	73	43	143
TK11332CMI	3.100	3.200	3.300	12	33	26	73	44	145
TK11333CMI	3.200	3.300	3.400	13	33	26	74	44	147
TK11335CMI	3.395	3.500	3.605	13	34	27	75	45	151
TK11338CMI	3.686	3.800	3.914	13	34	28	77	47	157
TK11340CMI	3.880	4.000	4.120	13	35	28	79	48	161
TK11345CMI	4.365	4.500	4.635	14	36	29	82	50	170
TK11347CMI	4.559	4.700	4.841	14	36	30	84	51	174
TK11348CMI	4.656	4.800	4.944	14	36	30	84	52	176
TK11350CMI	4.850	5.000	5.150	14	37	31	86	53	180
TK11355CMI	5.335	5.500	5.565	15	38	32	89	55	190
TK11360CMI	5.820	6.000	6.180	15	39	33	93	58	199
TK11380CMI	7.760	8.000	8.240	17	43	38	107	68	238

Notice.

Please contact your authorized TOKO representative for voltage availability.
 If you need a voltage other than the value listed in the above table, please contact TOKO.

9. TEST CIRCUIT

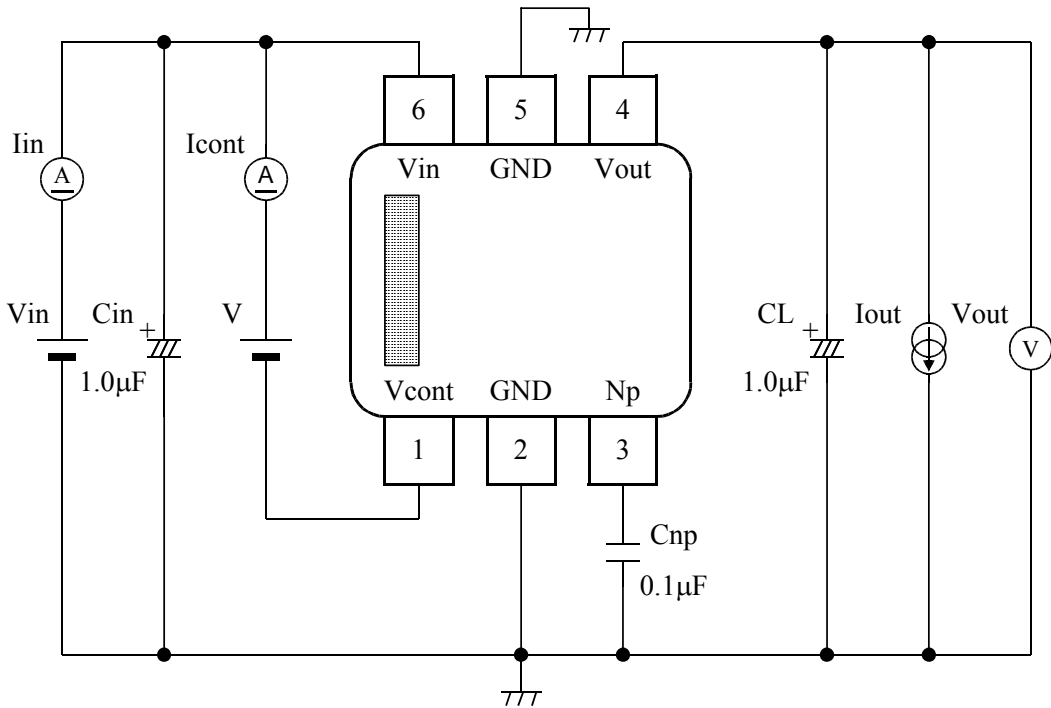

*2pin,5pin are connected in the IC.

10. APPLICATION EXAMPLE

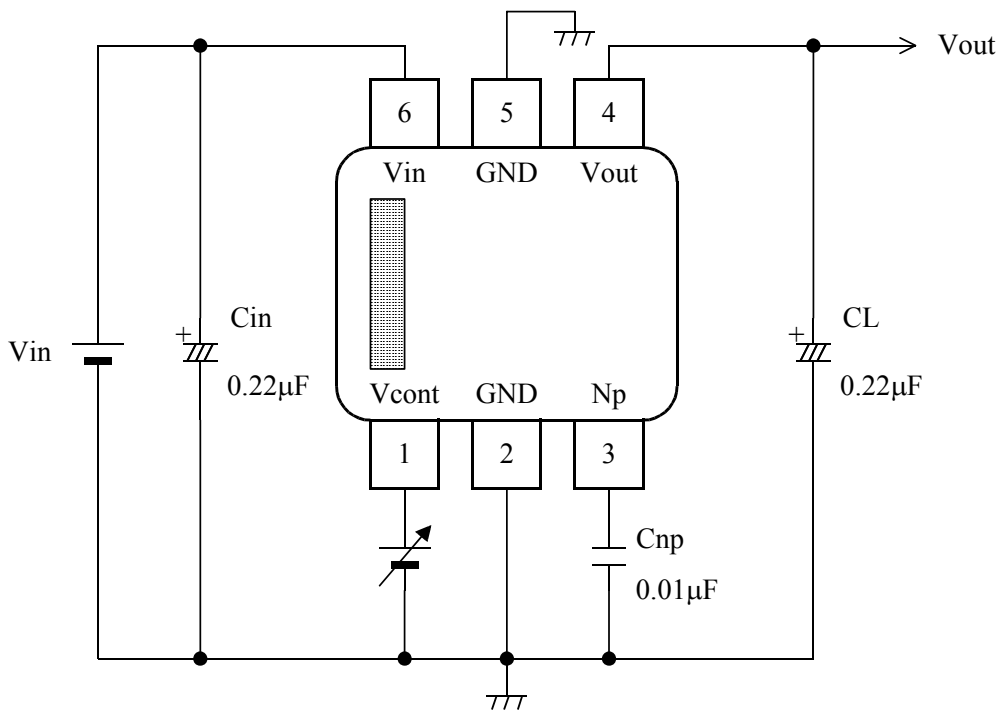

11. TYPICAL CHARACTERISTICS

11-1.DC CHARACTERISTICS

■ Line Regulation

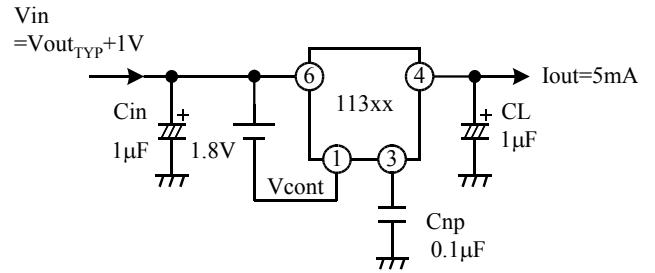
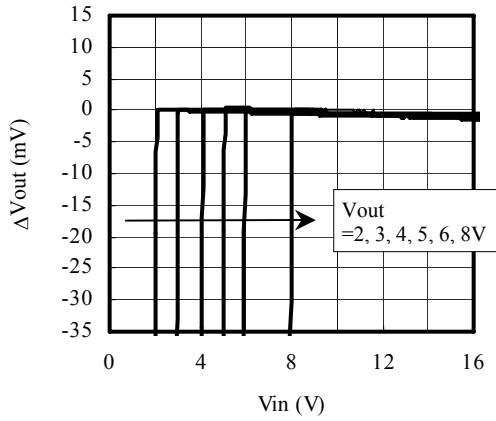

■ Vin vs Iin

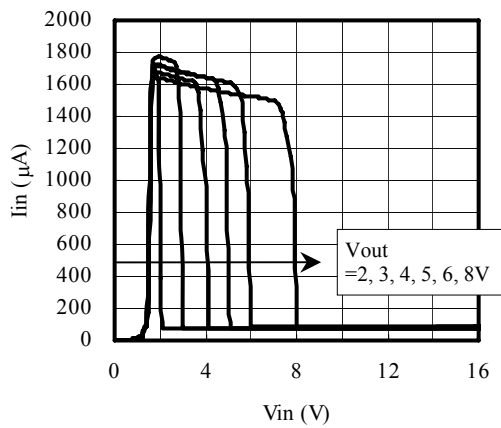

■ Vin vs Iin

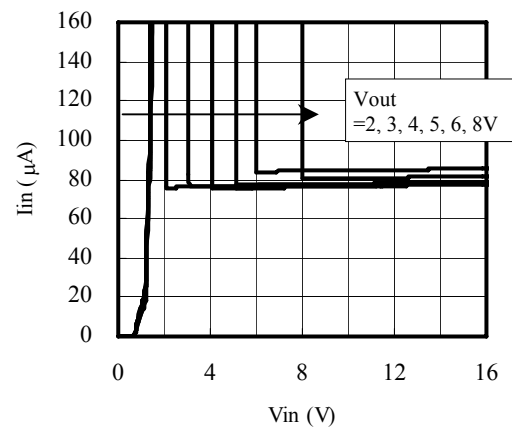

■ Load Regulation

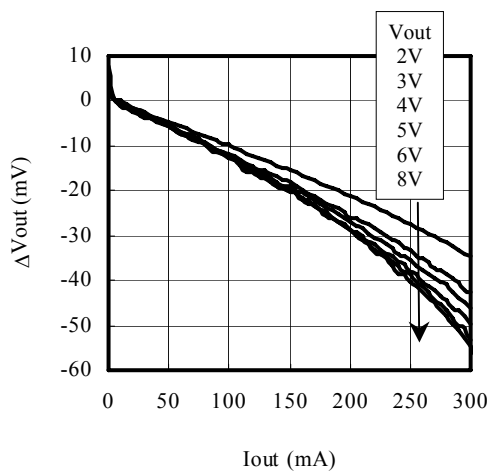

■ Short Circuit Current

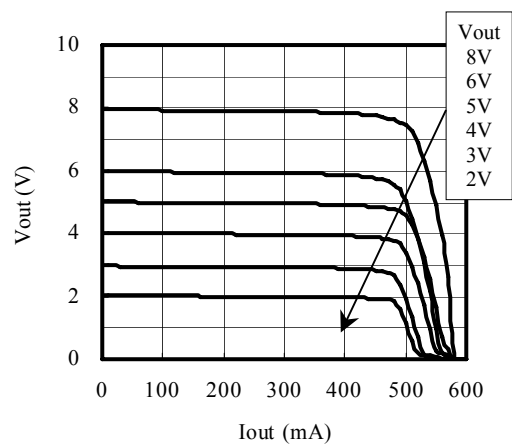

■ Reverse Bias Current

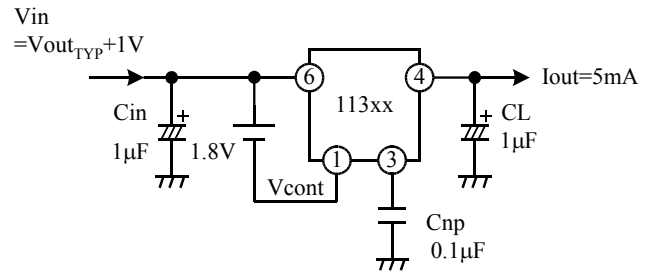
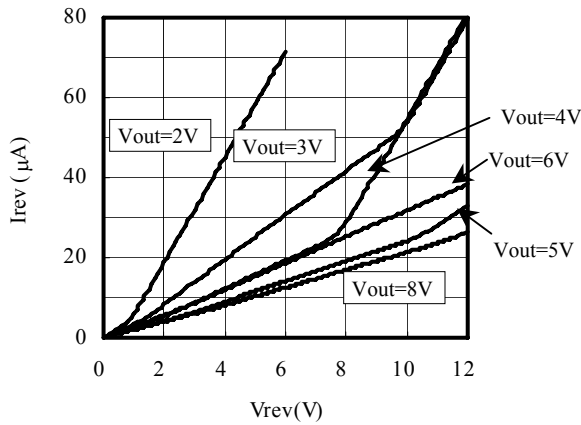

■ Dropout Voltage

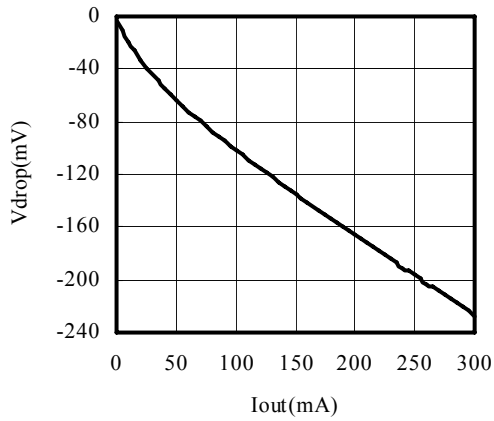

■ V_{in} vs V_{out} Regulation Point

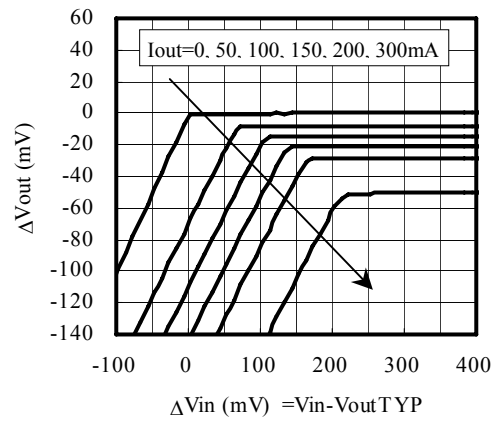

■ I_{in} (Off state)

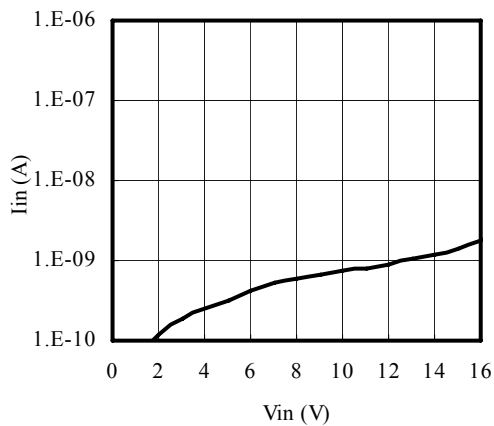

■ $V_{in} - V_{cont}$ vs I_{cont}

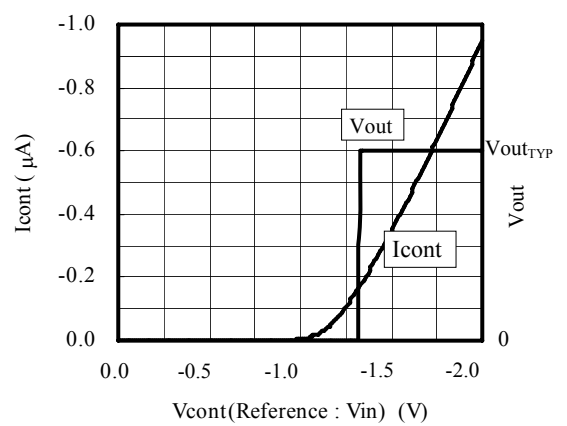

■ GND Pin Current

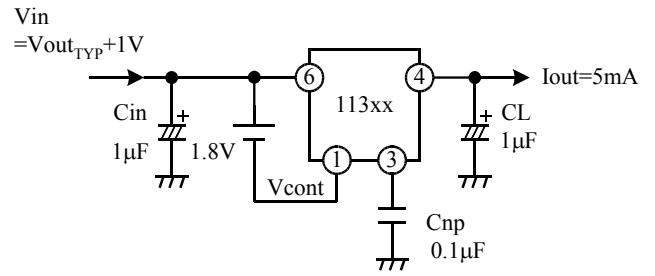
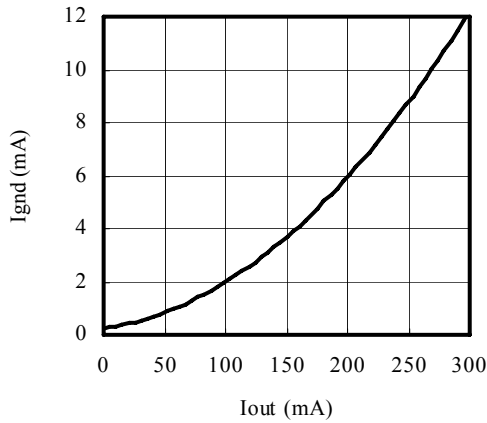

Temperature Characteristics

■ Iout MAX

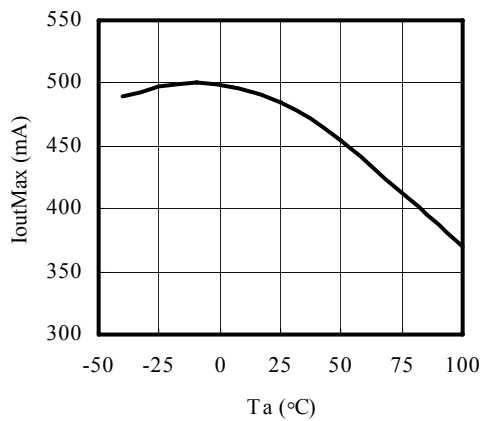

■ GND Pin Current

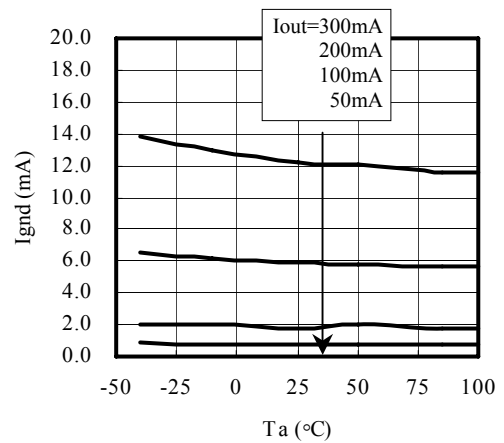

■ Control Current

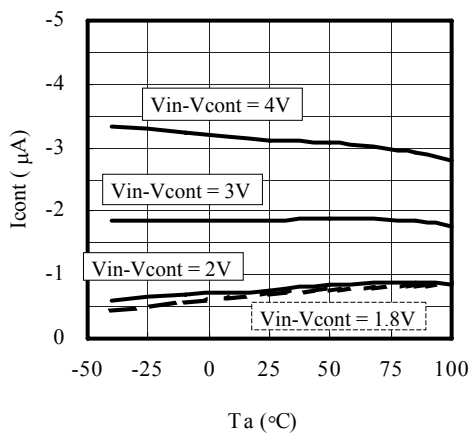

■ ON/OFF Point

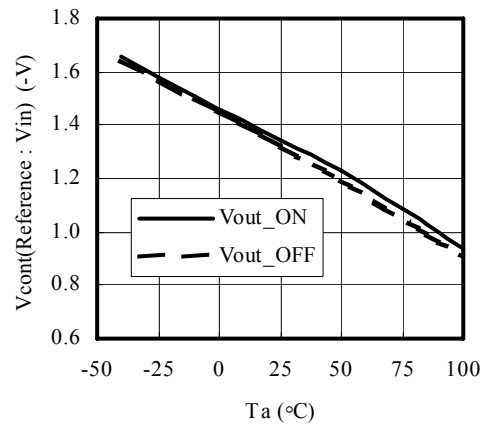

■ Dropout Voltage

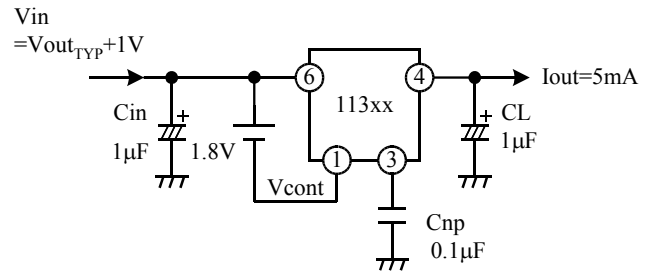
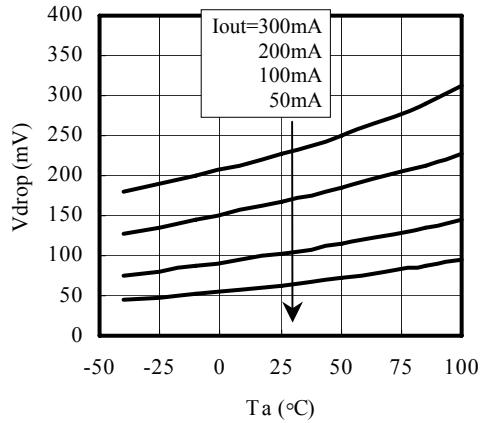

■ Vout (TK11320CM)

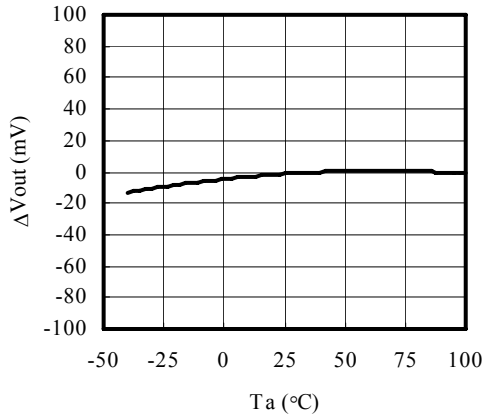

■ Vout (TK11330CM)

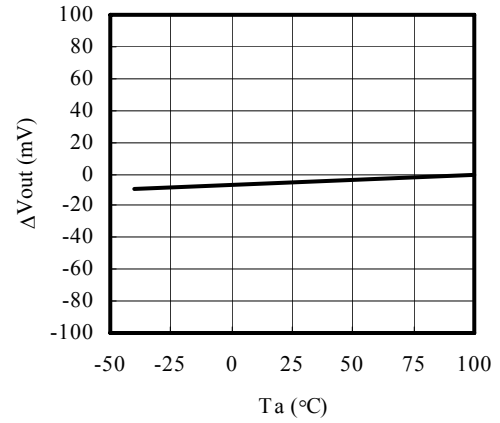

■ Vout (TK11340CM)

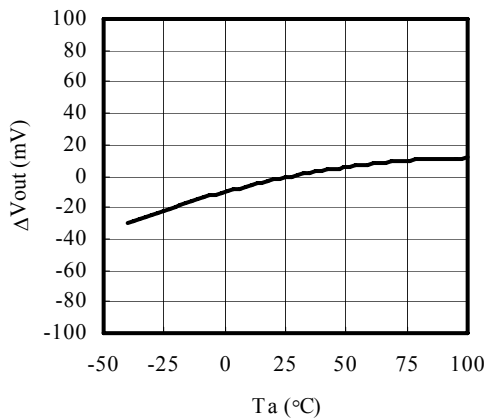

■ Vout (TK11350CM)

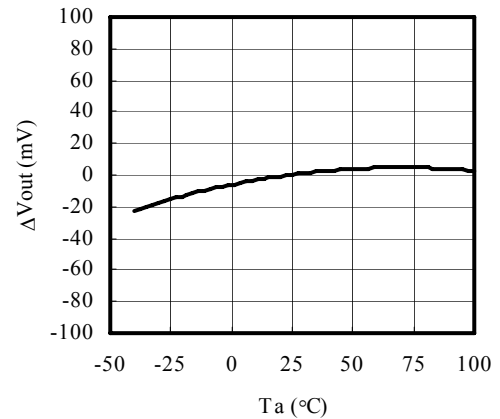

■ Vout (TK11360CM)

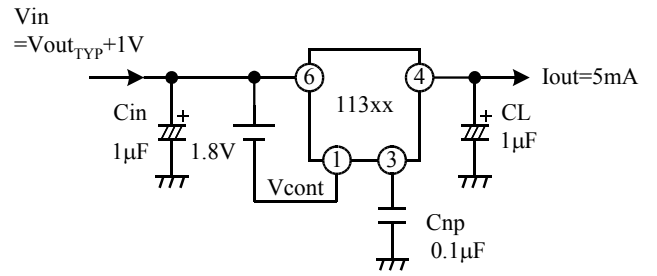
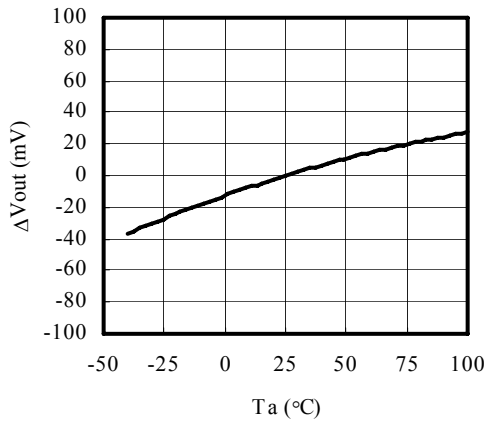

■ Vout (TK11380CM)

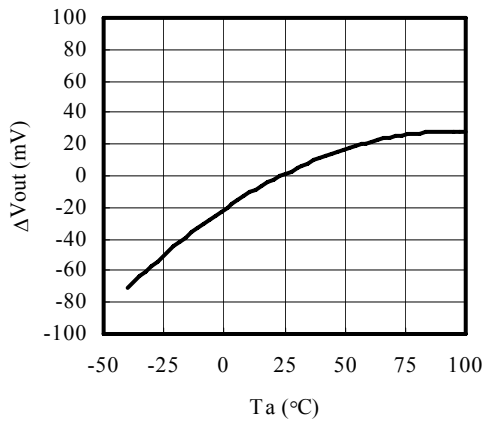

11-2. AC CHARACTERISTICS

Ripple Rejection

- CL = 1μF : Ceramic (C) , Tantalum (T)
Vout=2V

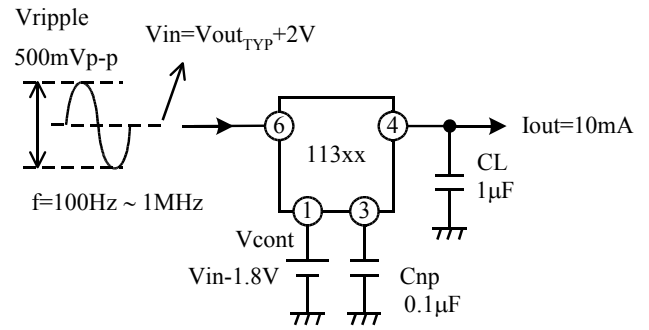
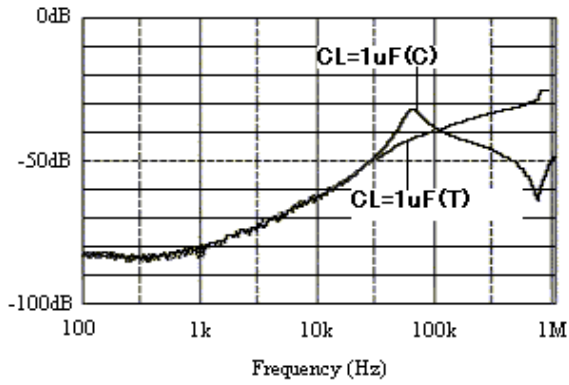

- CL = 1μF : Ceramic (C) , Tantalum (T)
Vout=3V

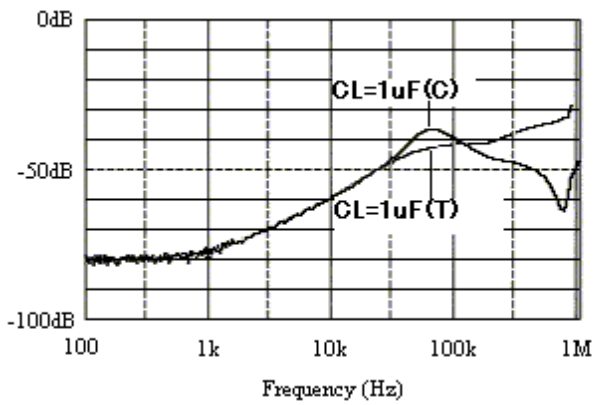

- CL = 1μF : Ceramic (C) , Tantalum (T)
Vout=4V

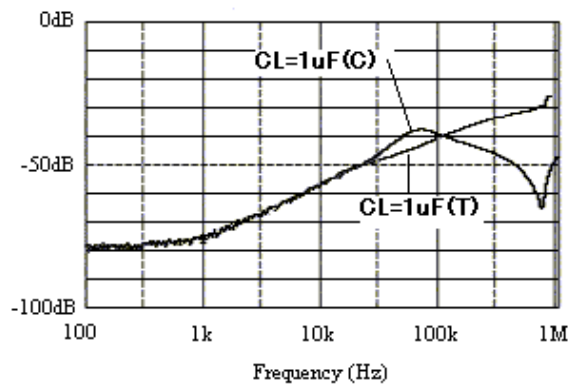

- CL = 1μF : Ceramic (C) , Tantalum (T)
Vout=5V

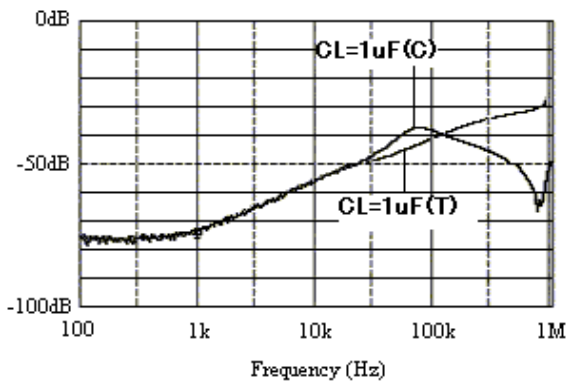

- CL = 1μF : Ceramic (C) , Tantalum (T)
Vout=6V

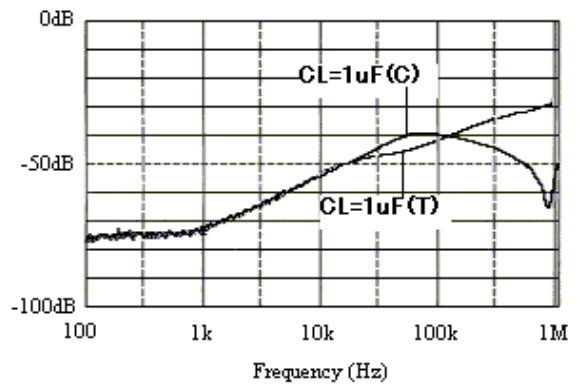

- CL = 1μF : Ceramic (C) , Tantalum (T)
Vout=8V

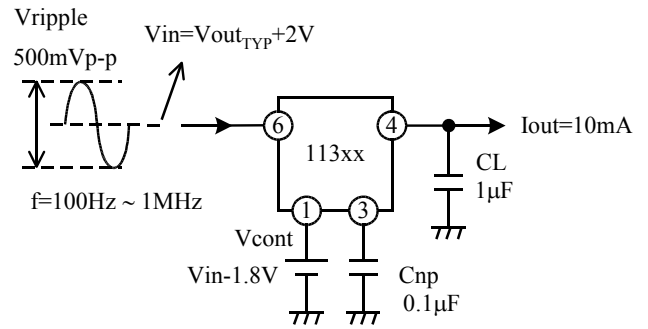
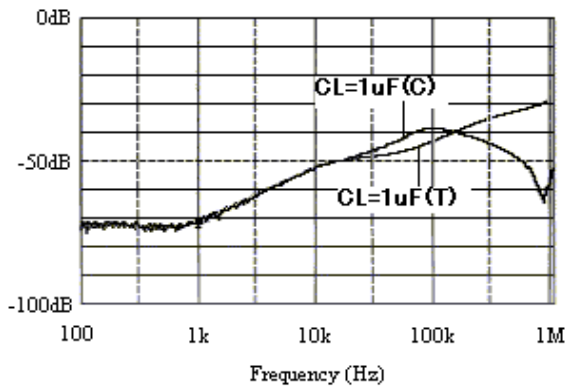

- CL = 0.22μF : Ceramic (C) , Tantalum (T)
Vout=3V

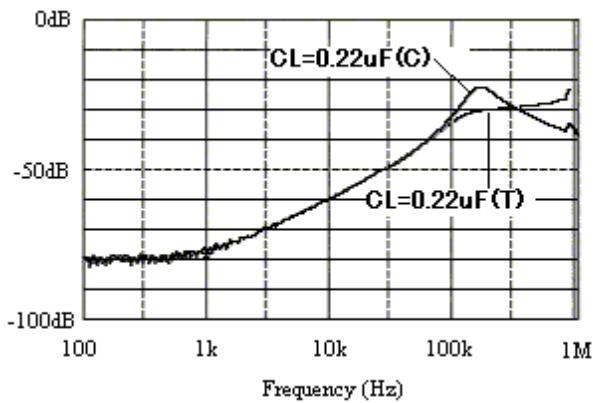

- CL = 0.22μF, 10μF : Tantalum (T)
Vout=3V

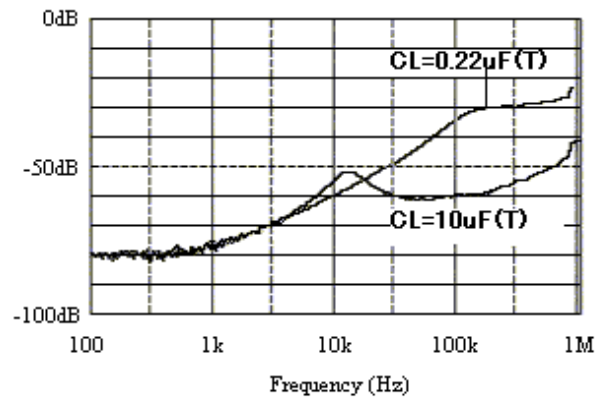

- Cnp = 0.001μF, 0.1μF : Tantalum (T)
Vout=3V

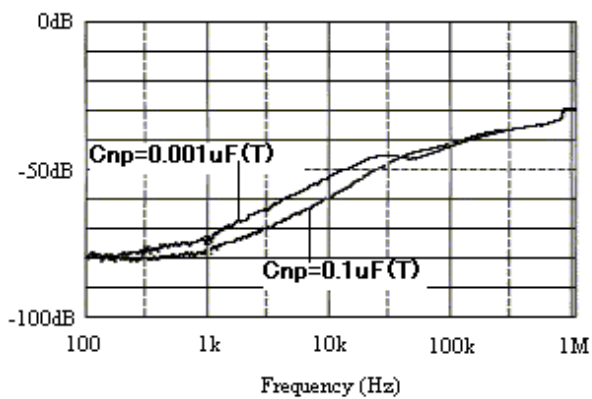

- Iout=0.5~300mA
Vout=3V

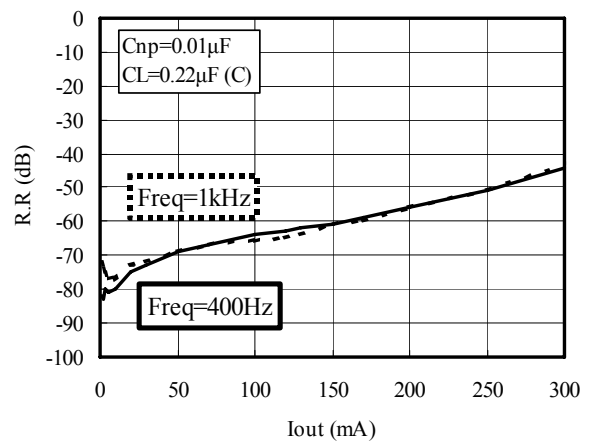

■ Low Vin
Vout=3V

Freq=1kHz, Cnp=0.01μF
CL=0.22μF (C), Vripple=100mVp-p

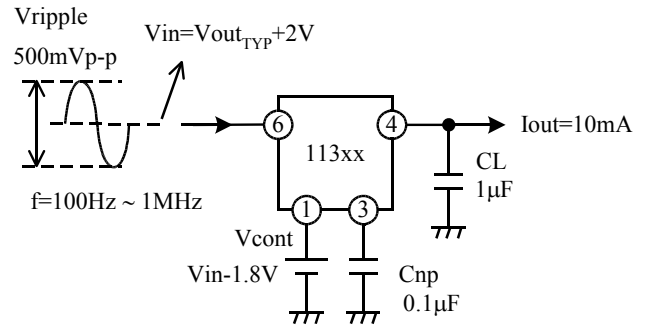
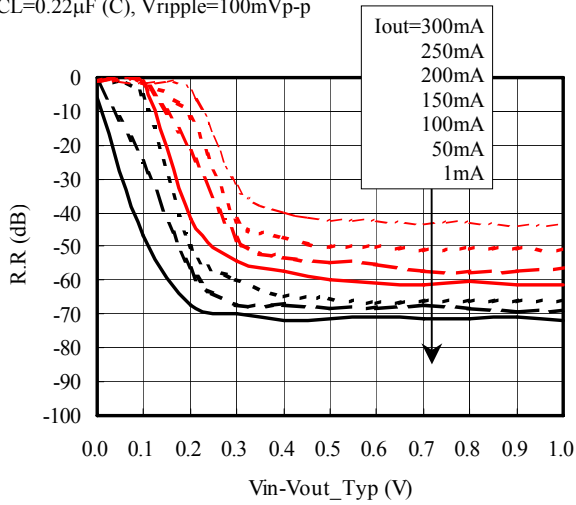

The ripple rejection (R.R) characteristic depends on the characteristic and the capacitance value of the capacitor connected to the output side. The R.R characteristic of 50kHz or more varies greatly with the capacitor on the output side and PCB pattern. If necessary, please confirm stability while operating.

ON/OFF Transient

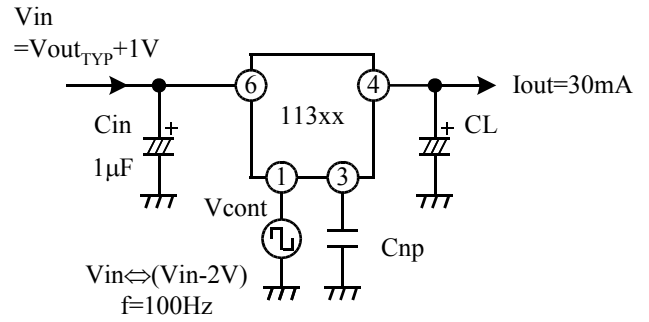

■ CL=0.22µF, 1.0µF, 2.2µF
Vout=3V

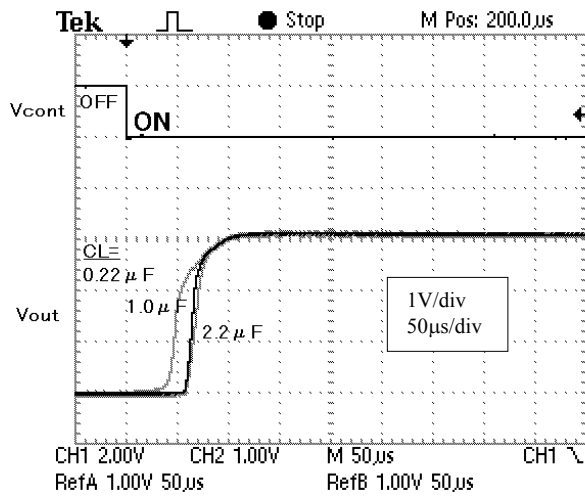

■ CL=0.22µF, 1.0µF, 2.2µF
Vout=3V

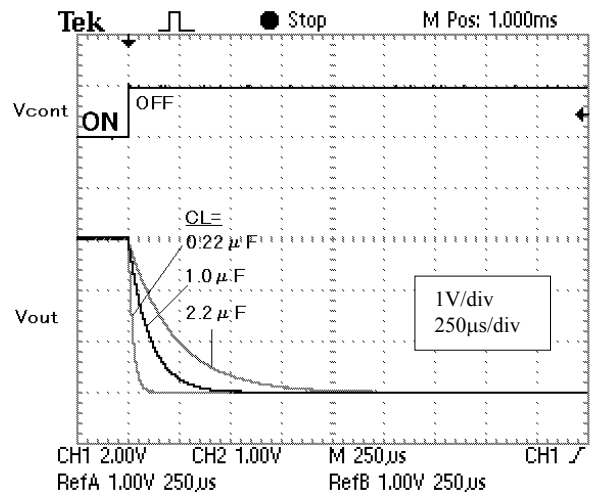

■ Cnp=0.001µF, 0.01µF, 0.1µF
Vout=3V

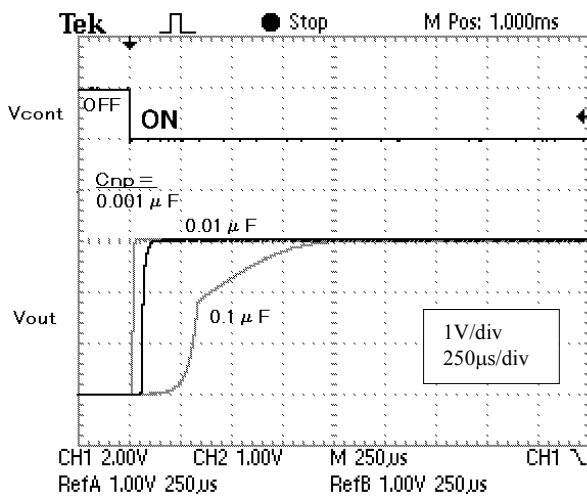

■ Cnp=0.001µF, CL=0.22µF, 1.0µF, 2.2µF
Vout=3V

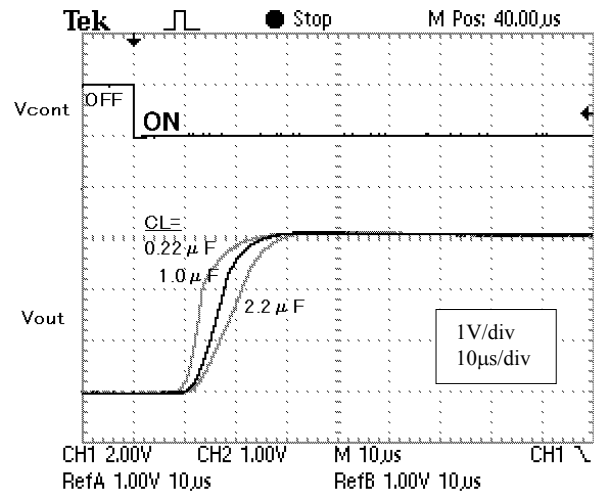

The rise time of the regulator depends on CL and Cnp; the fall time depends on CL.

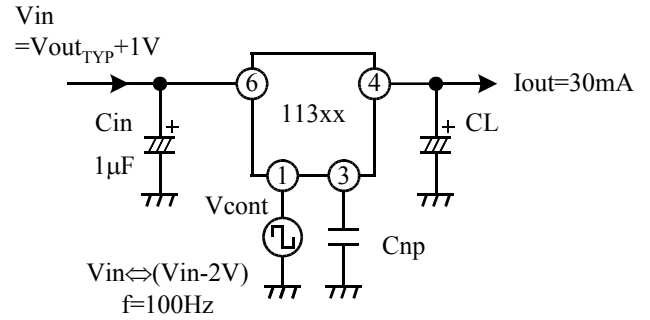
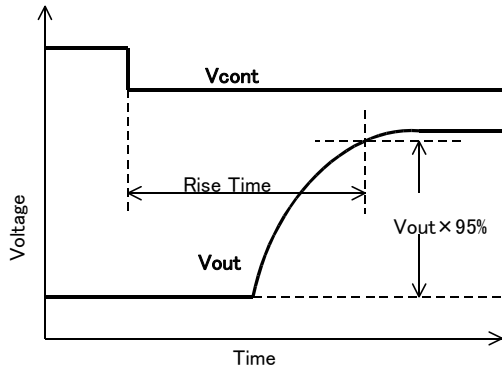

■ $V_{out} = 2V, 3V, 4V, 5V, 6V, 8V$

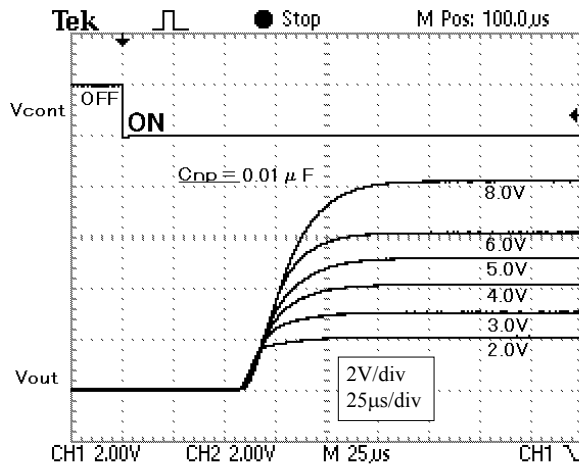

■ $V_{out} = 2V, 3V, 4V, 5V, 6V, 8V$

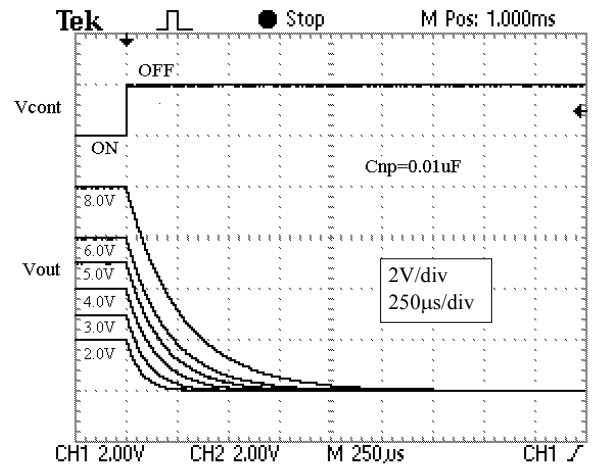

■ $V_{out} = 2V, 3V, 4V, 5V, 6V, 8V$

V_{cont} : one pulse (after discharge C_{np}, C_L)

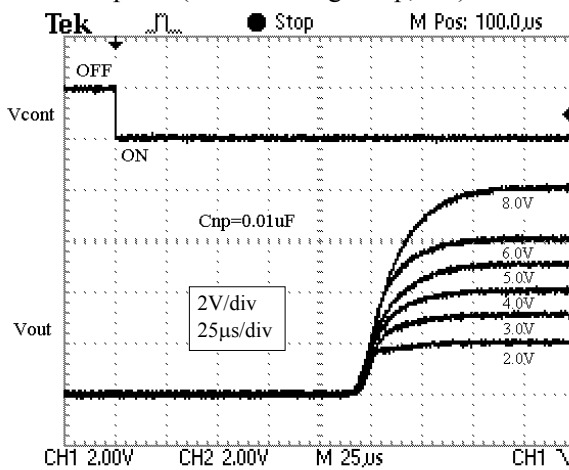

■ $V_{out} = 2V, 3V, 4V, 5V, 6V, 8V$

V_{cont} : one pulse (after discharge C_{np}, C_L)

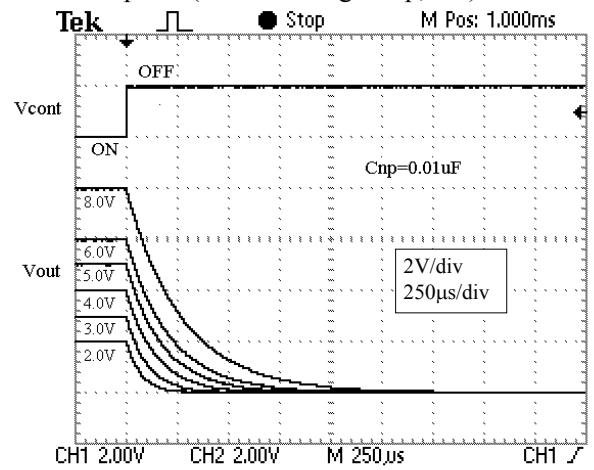

LOAD Transient

■ $CL=0.22\mu F, 1.0\mu F, 2.2\mu F, I_{out}=3\leftrightarrow 33mA$

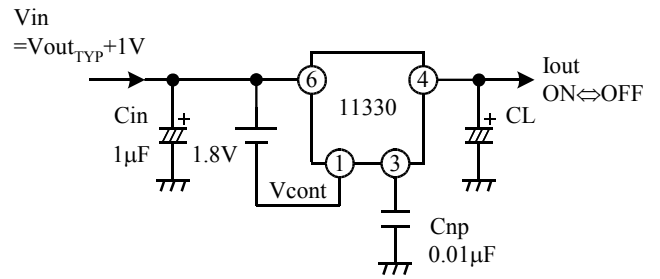
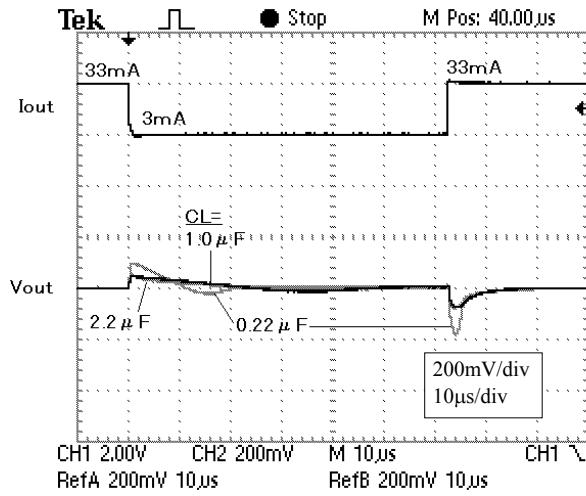

■ $I_{out}=0\leftrightarrow 30mA, 3\leftrightarrow 33mA$

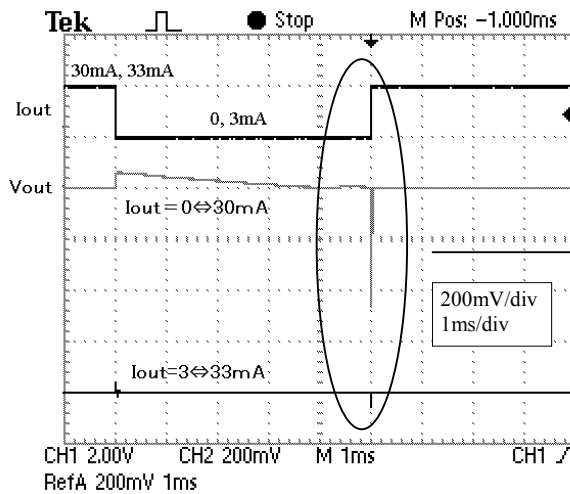

■ $I_{out}=0\rightarrow 30mA, 3\rightarrow 33mA$

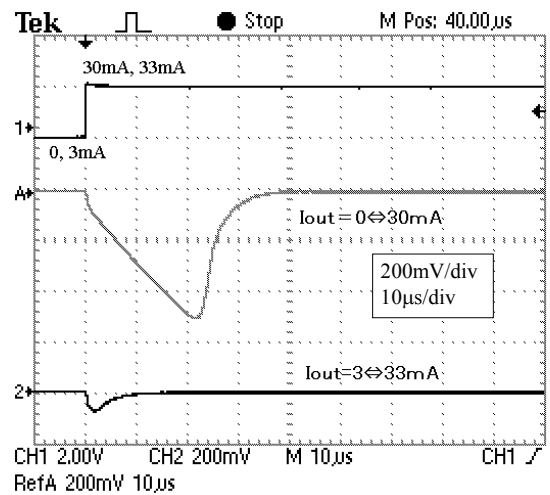

The output load transient characteristics can be greatly improved by adding a small load current to ground. (Refer to the above data curve)
 Increase the output capacitance CL when the load current change is fast and/or large.

LINE Transient

■ $CL=0.22\mu F, 1.0\mu F, 2.2\mu F$

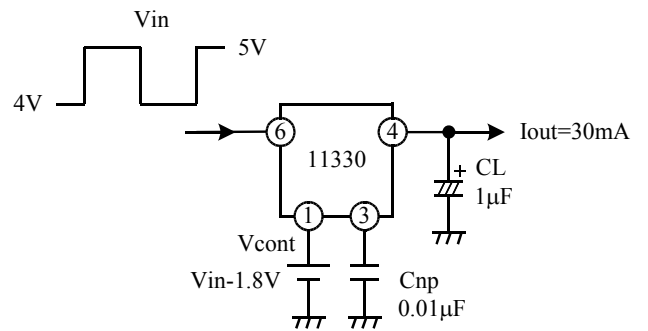
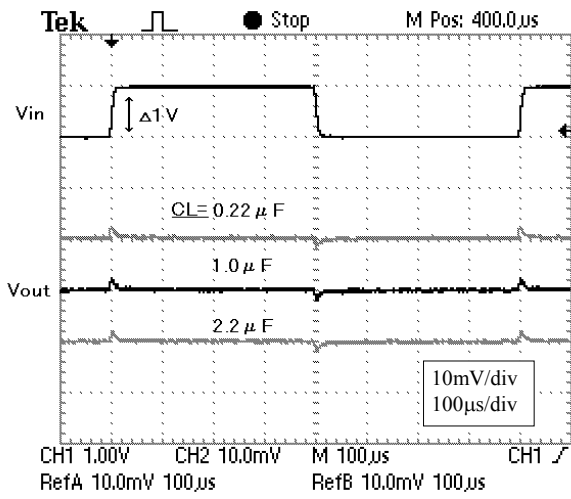

■ $Cnp=0.001\mu F, 0.01\mu F, 0.1\mu F$

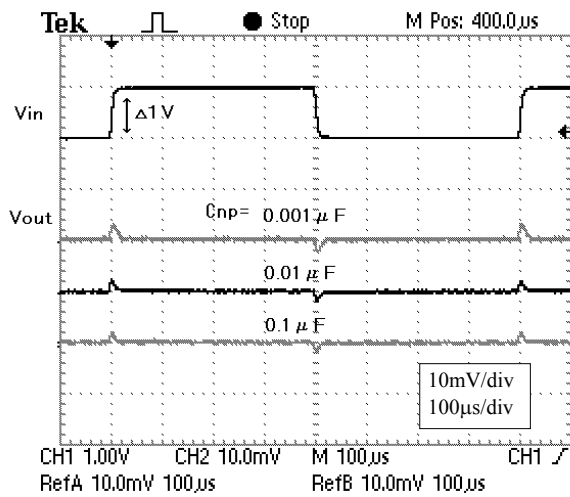

Output Noise Characteristics

■ Vout vs Noise

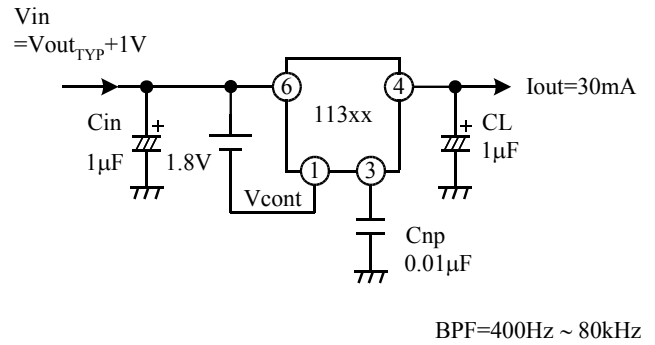
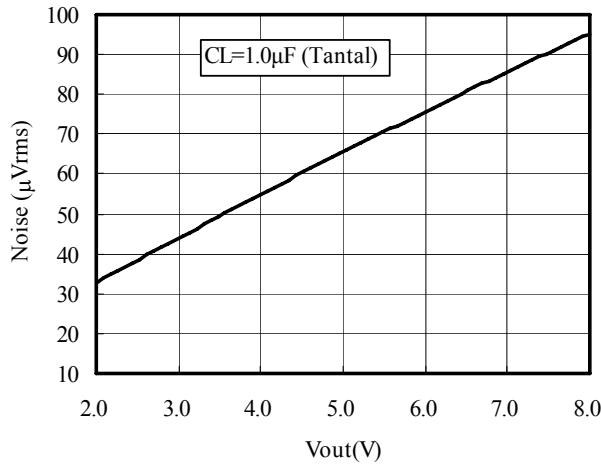

■ Cnp vs Noise (CL : Tantalum)
Vout=3.0V

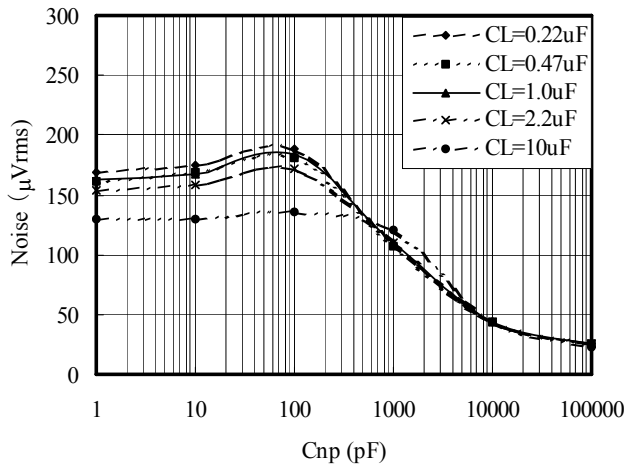

■ Cnp vs Noise (CL : Ceramic)
Vout=3.0V

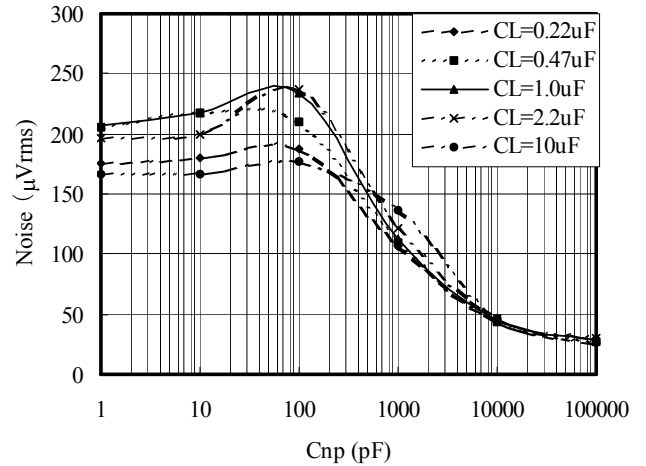

■ Iout vs Noise (CL : Tantal)
Vout=3.0V

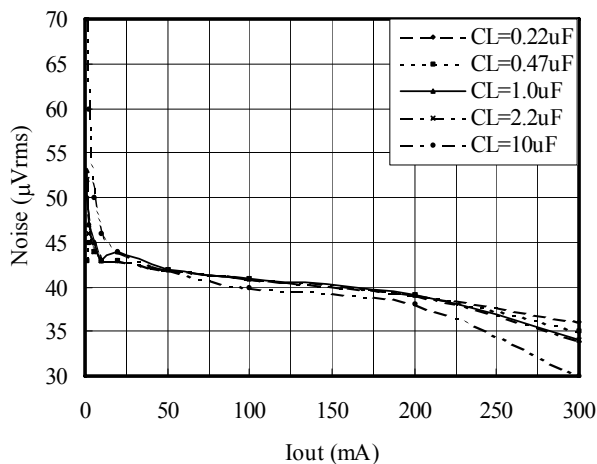

■ Iout vs Noise (CL : Ceramic)
Vout=3.0V

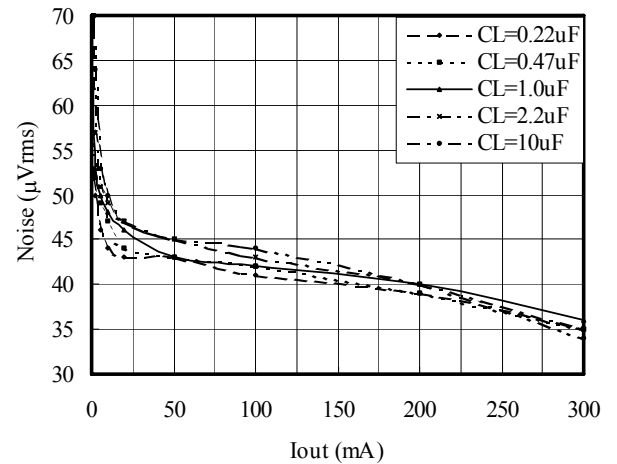

■ Frequency vs Noise

CL=0.22μF(Ceramic), Iout=10mA, Vout=3V

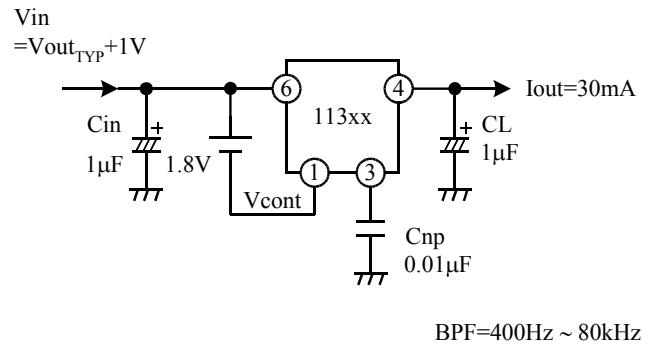
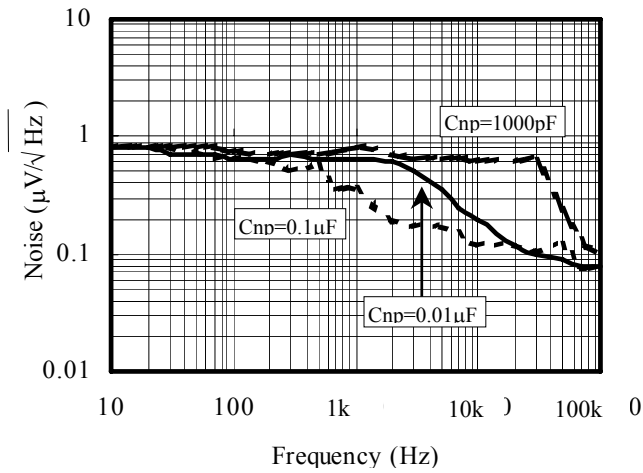

For better noise reduction, it is more effective to increase noise bypass capacitance Cnp without increasing output capacitance CL. The amount of noise increases with higher output voltages.

12. PIN DESCRIPTION

Pin No.	Pin Description	Internal Equivalent Circuit	Description
1	Vcont		<p>On/Off Control Terminal</p> <p>$V_{cont} < V_{in} - 1.8V$: ON $V_{cont} > V_{in} - 0.6V$: OFF *C Rank</p> <p>The pull-up resistor is not built-in.</p>
2	GND		GND Terminal
3	Np		<p>Noise Bypass Terminal</p> <p>Connect a bypass capacitor between GND.</p>
4	Vout		Output Terminal
5	GND		GND Terminal
6	Vin		Input Terminal

13. APPLICATIONS INFORMATION

13-1. Stability

Linear regulators require input and output capacitors in order to maintain the regulator's loop stability. If a 0.1μF capacitor is connected to the output side, the IC provides stable operation at any voltage in the practical current region. However, increase the CL capacitance when using the IC in the low current region and low voltage. Otherwise, the IC oscillates.

The equivalent series resistance (ESR) of the output capacitor must be in the stable operation area. However, it is recommended to use as large a value of capacitance as is practical. The output noise and the ripple noise decrease as the capacitance value increases. ESR values vary widely between ceramic and tantalum capacitors. However, tantalum capacitors are assumed to provide more ESR damping resistance, which provides greater circuit stability. This implies that a higher level of circuit stability can be obtained by using tantalum capacitors when compared to ceramic capacitors with similar values.

The input capacitor is necessary when the battery is discharged, the power supply impedance increases, or the line distance to the power supply is long.

This capacitor might be necessary on each individual IC even if two or more regulator ICs are used. It is not possible to determine this indiscriminately. Please confirm the stability while mounted

A recommended value of the application is as follows.

$$C_{in} = C_L \geq 0.22\mu F \text{ at } I_{out} \geq 0.5mA$$

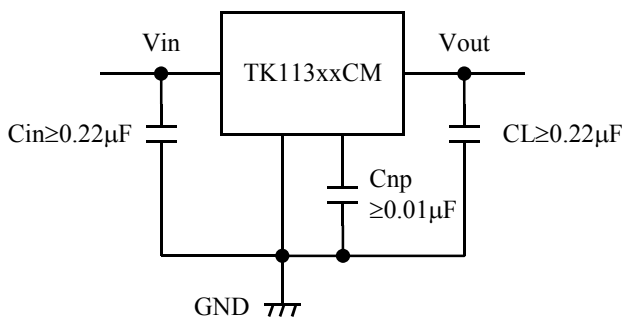

However, above recommended value does not satisfy some conditions.

See “Output Voltage, Output Current vs. Stable Operation Area“ on the next page.

Select the CL capacitance according to the condition of use.

If the fast load transient response is necessary, increase the CL capacitance as much as possible.

Output Voltage, Output Current vs. Stable Operation Area

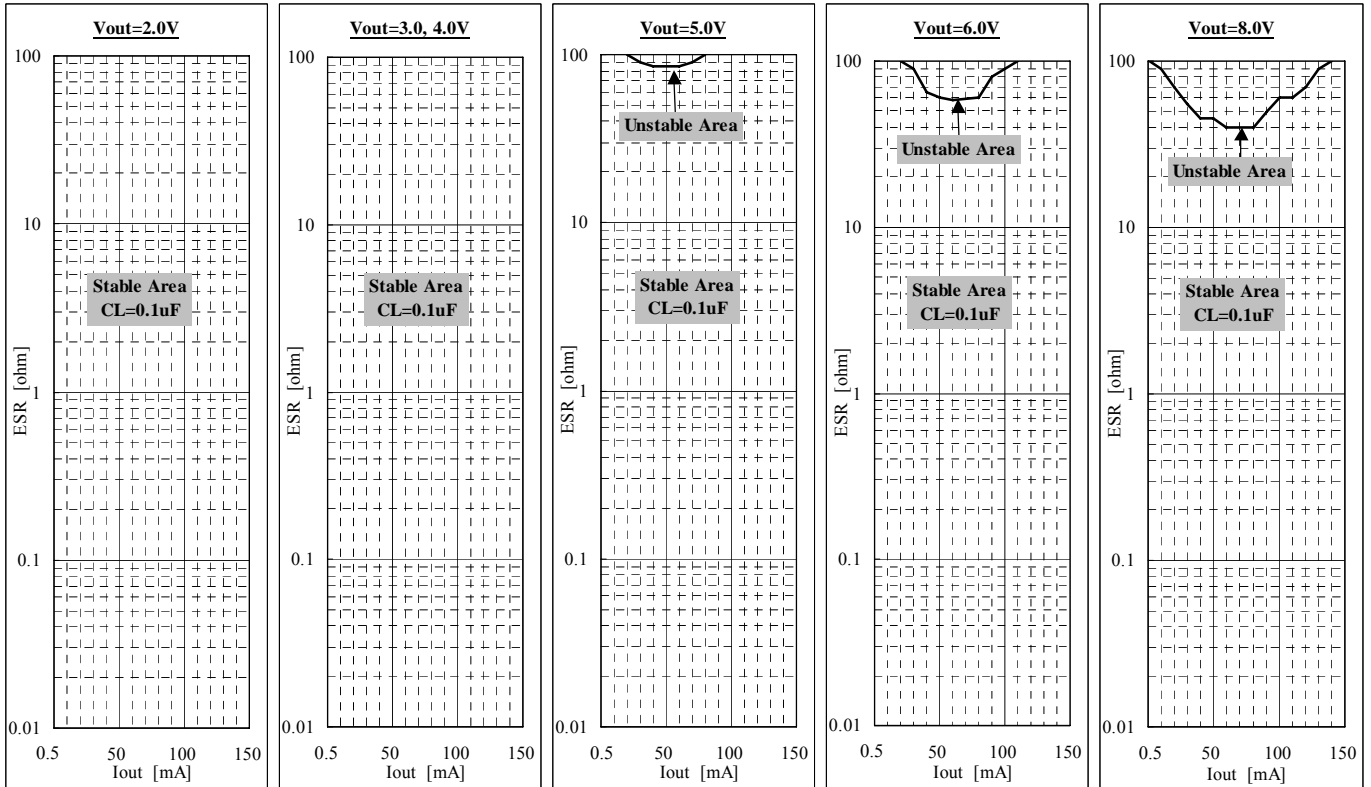

The above graphs show stable operation with a ceramic capacitor of 0.1 μ F (excluding the low current region). If the capacitance is not increased in the low voltage, low current area, stable operation may not be achieved. Please select the best output capacitor according to the voltage and current used. The stability of the regulator improves if a big output side capacitor is used (the stable operation area extends.) Please use as large a capacitance as is practical. Although operation above 150mA has not been described, stability is equal to or better than operation at 150mA.

For evaluation

- Kyocera : CM05B104K10AB , CM05B224K10AB , CM105B104K16A , CM105B224K16A , CM21B225K10A
- Murata : GRM36B104K10 , GRM42B104K10 , GRM39B104K25 , GRM39B224K10 , GRM39B105K6.3

ex. Ceramic Capacitance vs Voltage, Temperature

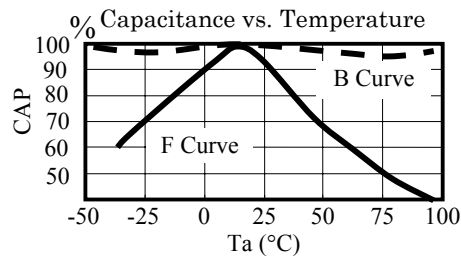
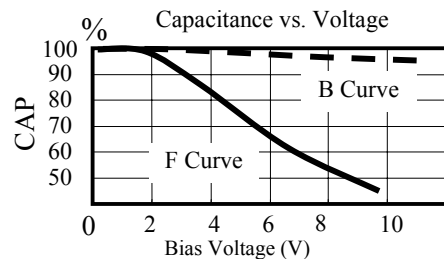

Generally, a ceramic capacitor has both a temperature characteristic and a voltage characteristic. Please consider both characteristics when selecting the part. The B curves are the recommend characteristics.

13-2. Definition of term

◆ **Output Voltage (Vout)**

The output voltage is specified with $V_{in}=(V_{out_{TYP}}+1V)$ and $I_{out}=5mA$.

◆ **Maximum Output Current (Iout MAX)**

The rated output current is specified under the condition where the output voltage drops 0.9V times the value specified with $I_{out}=5mA$. The input voltage is set to $V_{out_{TYP}}+1V$ and the current is pulsed to minimize temperature effect.

◆ **Dropout Voltage (Vdrop)**

The dropout voltage is the difference between the input voltage and the output voltage at which point the regulator starts to fall out of regulation. Below this value, the output voltage will fall as the input voltage is reduced. It is dependent upon the load current and the junction temperature.

◆ **Line Regulation (LinReg)**

Line regulation is the ability of the regulator to maintain a constant output voltage as the input voltage changes. The line regulation is specified as the input voltage is changed from $V_{in}=V_{out_{TYP}}+1V$ to $V_{in}=V_{out_{TYP}}+6V$. It is a pulse measurement to minimize temperature effect.

◆ **Load Regulation (LoaReg)**

Load regulation is the ability of the regulator to maintain a constant output voltage as the load current changes. It is a pulsed measurement to minimize temperature effects with the input voltage set to $V_{in}=V_{out_{TYP}}+1V$. The load regulation is specified under an output current step condition of 5mA to 100mA.

◆ **Ripple Rejection (R.R)**

Ripple rejection is the ability of the regulator to attenuate the ripple content of the input voltage at the output. It is specified with 500mV_{rms}, 1kHz super-imposed on the input voltage, where $V_{in}=V_{out}+2V$. Ripple rejection is the ratio of the ripple content of the output vs. input and is expressed in dB.

◆ **Standby Current (Istandby)**

Standby current is the current which flows into the regulator when the output is turned off by the control function ($V_{cont}=V_{in}$).

◆ **Over Current Sensor**

The over current sensor protects the device when there is excessive output current. It also protects the device if the output is accidentally connected to ground. (When external transistor is used, the protection operates at 10mA at the base terminal)

◆ **Thermal Sensor**

The thermal sensor protects the device in case the junction temperature exceeds the safe value ($T_J=150^{\circ}C$). This temperature rise can be caused by external heat, excessive power dissipation caused by large input to output voltage drops, or excessive output current. The regulator will shut off when the temperature exceeds the safe value. As the junction temperatures decrease, the regulator will begin to operate again. Under sustained fault conditions, the regulator output will oscillate as the device turns off then resets. Damage may occur to the device under extreme fault.

Please prevent the loss of the regulator when this protection operates, by reducing the input voltage or providing better heat efficiency.

* In the case that the power, $V_{in} \times I_{short}$ (Short Circuit Current), becomes more than twice of the maximum rating of its power dissipation in a moment, there is a possibility that the IC is destroyed before internal thermal protection works.

◆ **Reverse Voltage Protection**

Reverse voltage protection prevents damage due to the output voltage being higher than the input voltage. This fault condition can occur when the output capacitor remains charged and the input is reduced to zero, or when an external voltage higher than the input voltage is applied to the output side

◆ **ESD**

MM : 200pF 0Ω 200V or more
HBM : 100pF 1.5kΩ 2000V or more

13-3. Layout

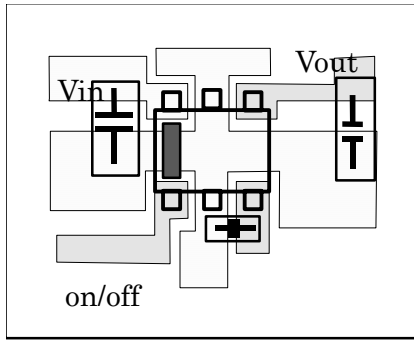

PCB Material : Glass epoxy (t=0.8mm)

Please do derating with 4.8mW/°C at Pd=600mW and 25°C or more. Thermal resistance (θja) is=208°C/W.

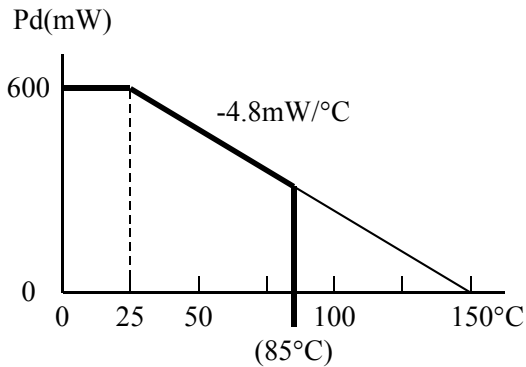

The package loss is limited at the temperature that the internal temperature sensor works (about 150°C). Therefore, the package loss is assumed to be an internal limitation. There is no heat radiation characteristic of the package unit assumed because of the small size. Heat is carried away by the device being mounted on the PCB. This value changes by the material and the copper pattern etc. of the PCB. The losses are approximately 600mW. Enduring these losses becomes possible in a lot of applications operating at 25°C.

The overheating protection circuit operates when there are a lot of losses with the regulator (When outside temperature is high or heat radiation is bad). The output current cannot be pulled enough and the output voltage will drop when the protection circuit operates. When the junction temperature reaches 150°C, the IC is shut down. However, operation begins at once when the IC stops operation and the temperature of the chip decreases.

How to determine the thermal resistance when mounted on PCB

The thermal resistance when mounted is expressed as follows:

$$T_j = \theta_{ja} \times P_d + T_a$$

Tj of IC is set around 150°C. Pd is the value when the thermal sensor is activated.

If the ambient temperature is 25°C, then:

$$150 = \theta_{ja} \times P_d + 25$$

$$\theta_{ja} = 125 / P_d \text{ (}^\circ\text{C / mW)}$$

Pd is easily calculated.

Mount the IC on the print circuit board. Short between the output pin and ground. after that, raise input voltage from 0V to evaluated voltage (see*1) gradually.

At shorted the output pin, the power dissipation P_D can be expressed as P_D=V_{in} × I_{in}.

The input current decreases gradually as the temperature of the chip becomes high. After a while, it reaches the thermal equilibrium. Use this current value at the thermal equilibrium.

In almost all the cases, it shows 600mW(SOT23L-6) or more.

*1 In the case that the power, V_{in} × I_{short}(Short Circuit Current), becomes more than twice of the maximum rating of its power dissipation in a moment, there is a possibility that the IC is destroyed before internal thermal protection works.

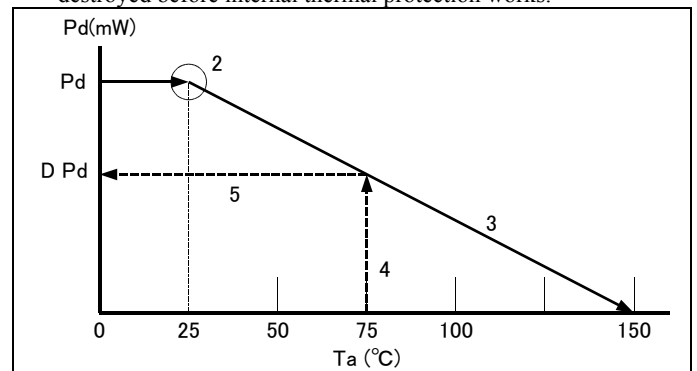

Procedure (When mounted on PCB.)

1. Find Pd (V_{in}×I_{in} when the output side is short-circuited).
2. Plot Pd against 25°C.
3. Connect Pd to the point corresponding to the 150°C with a straight line.
4. In design, take a vertical line from the maximum operating temperature (e.g., 75°C) to the derating curve.
5. Read off the value of Pd against the point at which the vertical line intersects the derating curve. This is taken as the maximum power dissipation DPd.
6. DPd ÷ (V_{inmax}-V_{out})=I_{out} (at 75°C)

The maximum output current at the highest operating temperature will be **I_{out} ≈ DPd ÷ (V_{inMax}-V_{out})**.

Please use the device at low temperature with better radiation. The lower temperature provides better quality.

13-4. On/Off Control

It is recommended to turn the regulator Off when the circuit following the regulator is non-operating. A design with little electric power loss can be implemented. We recommend the use of the on/off control of the regulator without using a high side switch to provide an output from the regulator. A highly accurate output voltage with low voltage drop is obtained. Because the control current is small, it is possible to control it directly by CMOS logic.

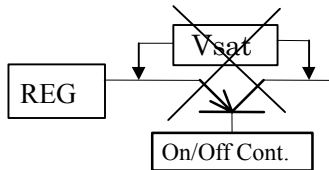

Control Terminal Voltage (Vcont)	ON/OFF State
$V_{cont} < V_{in} - 1.8V$	ON
$V_{cont} > V_{in} - 0.6V$	OFF

*C Rank

The pull-up resistor is not built-in at control terminal. If a pull-up resistor is necessary according as the control driver, connect the control terminal with a pull-up resistance (Rp-up).

If the control function is not used, connect the control terminal to GND.

It is possible to reduce the control current by inserting a series resistor (Rc). However, be careful the ON/OFF level may change. Or “will change”

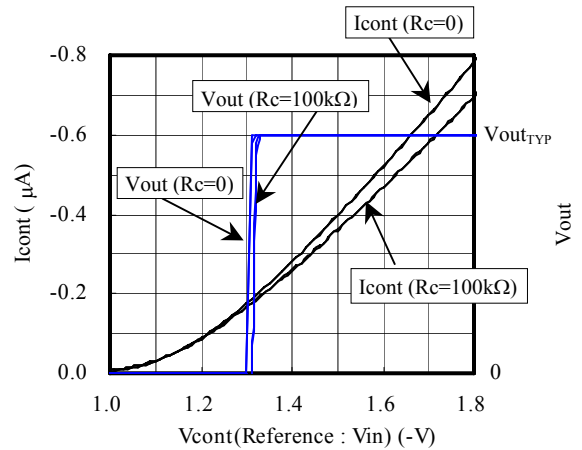
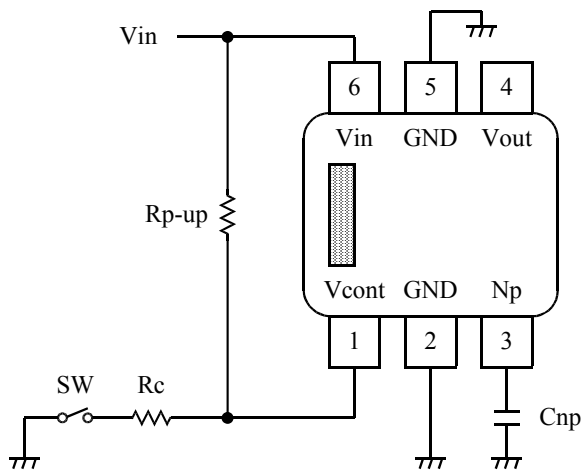

Parallel Connected ON/OFF Control

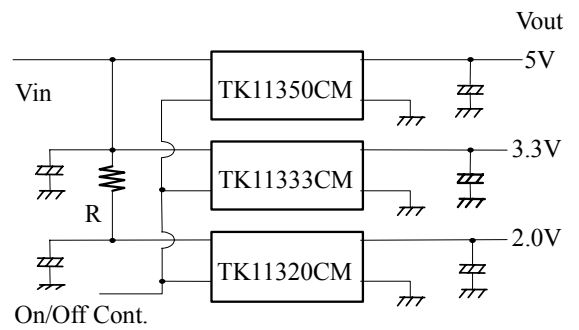

The above figure is multiple regulators being controlled by a single On/Off control signal. There is fear of overheating, because the power loss of the low voltage side IC (TK11320CM) is large. The series resistor (R) is put in the input line of the low output voltage regulator in order to prevent over-dissipation. The voltage dropped across the resistor reduces the large input-to-output voltage across the regulator, reducing the power dissipation in the device. When the thermal sensor works, a decrease of the output voltage, oscillation, etc. may be observed.

13-5. Noise Bypass

The noise and the ripple rejection characteristics depend on the capacitance on the Np terminal.

The ripple rejection characteristic of the low frequency region improves by increasing the capacitance of Cnp.

A standard value is $C_{np}=0.1\mu\text{F}$. Increase Cnp in a design with important output noise and ripple rejection requirements. The IC will not be damaged if the capacitor value is increased.

The on/off switching speed changes depending on the Np terminal capacitance. The switching speed slows when the capacitance is large.

13-6. Outline ; PCB ; Stamps

SOT23L-6

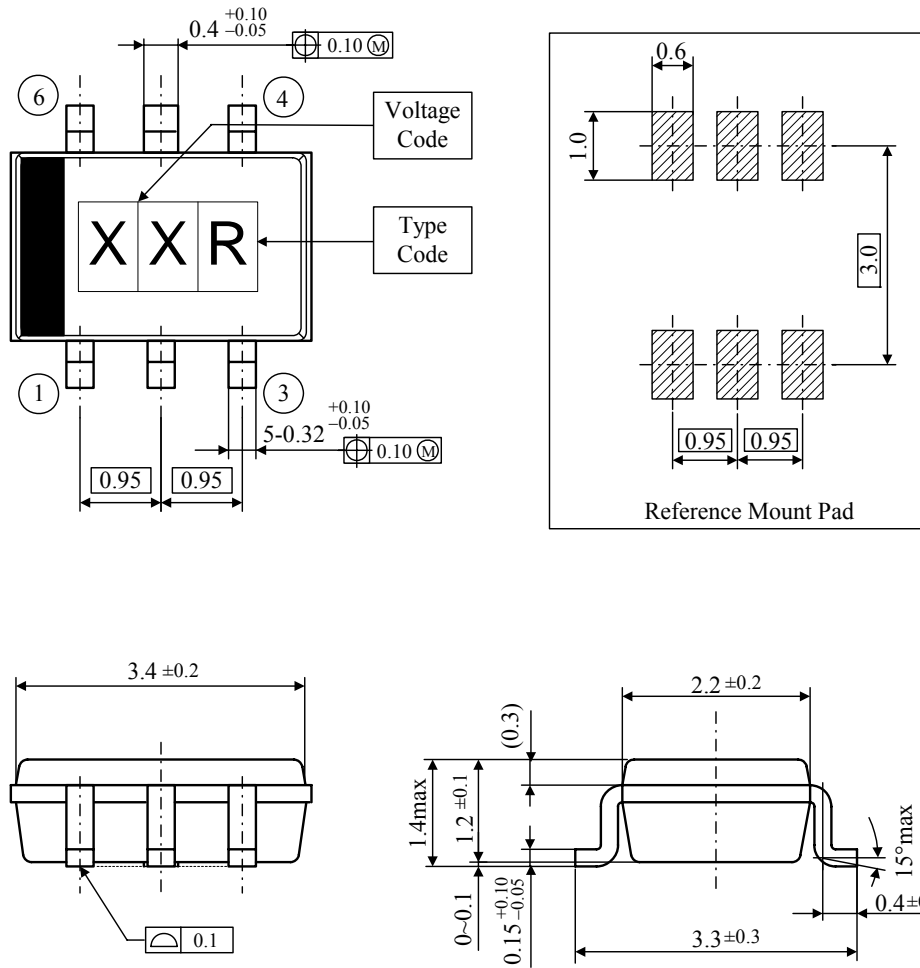

Unit : mm

Package Structure

Package Material : Epoxy Resin
 Terminal Material : Copper Alloy
 Mass (Reference) : 0.023g

V OUT	V CODE	V OUT	V CODE	V OUT	V CODE
2.0V	20	3.2V	32	6.0V	60
2.1	21	3.3	33	8.0	80
2.2	22	3.5	35		
2.5	25	3.8	38		
2.6	26	4.0	40		
2.7	27	4.5	45		
2.8	28	4.7	47		
2.9	29	4.8	48		
3.0	30	5.0	50		
3.1	31	5.5	55		

The output voltage table indicates the standard value when manufactured.
 Please contact your authorized Toko representative for voltage availability.

14. NOTES

- Please be sure that you carefully discuss your planned purchase with our office if you intend to use the products in this application manual under conditions where particularly extreme standards of reliability are required, or if you intend to use products for applications other than those listed in this application manual.
 - Power drive products for automobile, ship or aircraft transport systems; steering and navigation systems, emergency signal communications systems, and any system other than those mentioned above which include electronic sensors, measuring, or display devices, and which could cause major damage to life, limb or property if misused or failure to function.
 - Medical devices for measuring blood pressure, pulse, etc., treatment units such as coronary pacemakers and heat treatment units, and devices such as artificial organs and artificial limb systems which augment physiological functions.
 - Electrical instruments, equipment or systems used in disaster or crime prevention.

- Semiconductors, by nature, may fail or malfunction in spite of our devotion to improve product quality and reliability. We urge you to take every possible precaution against physical injuries, fire or other damages which may cause failure of our semiconductor products by taking appropriate measures, including a reasonable safety margin, malfunction preventive practices and fire-proofing when designing your products.

- This application manual is effective from Oct. 2006. Note that the contents are subject to change or discontinuation without notice. When placing orders, please confirm specifications and delivery condition in writing.

- TOKO is not responsible for any problems nor for any infringement of third party patents or any other intellectual property rights that may arise from the use or method of use of the products listed in this application manual. Moreover, this application manual does not signify that TOKO agrees implicitly or explicitly to license any patent rights or other intellectual property rights which it holds.

- None of ozone depleting substances(ODS) under the Montreal Protocol is used in manufacturing process of us.

15. OFFICES

If you need more information on this product and other TOKO products, please contact us.

- TOKO Inc. Headquarters
 1-17, Higashi-yukigaya 2-chome, Ohta-ku, Tokyo, 145-8585, Japan
 TEL: +81.3.3727.1161
 FAX: +81.3.3727.1176 or +81.3.3727.1169
 Web site: <http://www.toko.co.jp/>

- TOKO America
 Web site: <http://www.toko.com/>

- TOKO Europe
 Web site: <http://www.toko-europe.com/>

- TOKO Hong Kong
 Web site: <http://www.toko.com.hk/>

- TOKO Taiwan
 Web site: <http://www.toko-hc.com.tw/>

- TOKO Singapore
 Web site: <http://www.toko.com.sg/>

- TOKO Seoul
 Web site: <http://www.toko.co.kr/>

- TOKO Manila
 Web site: <http://www.toko.com.ph/>

- TOKO Brazil
 Web site: <http://www.toko.com.br/>



YOUR DISTRIBUTOR