



ICL3221EM

±15kV ESD Protected, +3V, 1µA, 250kbps, RS-232 Transmitters/Receivers

ICL3221EM

The Intersil ICL3221EM devices are 3.0V powered RS-232 transmitters/receivers which meet EIA/TIA-232 and V.28/V.24 specifications. Additionally, they provide ±15kV ESD protection (IEC61000-4-2 Air Gap and Human Body Model) on transmitter outputs and receiver inputs (RS-232 pins). Targeted applications are PDAs, Palmtops, and notebook and laptop computers where the low operational, and even lower standby, power consumption is critical. Efficient on-chip charge pumps, coupled with manual and automatic power-down functions, reduce the standby supply current to a 1µA trickle. Small footprint packaging, and the use of small, low value capacitors ensure board space savings as well. Data rates greater than 250kbps are guaranteed at worst case load conditions. The device is fully compatible with 3.3V-only systems.

The ICL3221EM features an automatic power-down function which powers down the on-chip power-supply and driver circuits. This occurs when an attached peripheral device is shut off or the RS-232 cable is removed, conserving system power automatically without changes to the hardware or operating system. These devices power up again when a valid RS-232 voltage is applied to any receiver input.

Table 1 summarizes the features of the ICL3221EM.

Related Literature

- Technical Brief [TB363](#) "Guidelines for Handling and Processing Moisture Sensitive Surface Mount Devices (SMDs)"

Features

- ESD Protection for RS-232 I/O Pins to ±15kV (IEC61000)
- Drop in Replacement for MAX3221E
- RS-232 Compatible with V_{CC} = 2.7V
- Meets EIA/TIA-232 and V.28/V.24 Specifications at 3V
- Latch-Up Free
- On-Chip Voltage Converters Require Only Four External 0.1µF Capacitors
- Manual and Automatic Power-down Features
- Receiver Hysteresis For Improved Noise Immunity
- Guaranteed Minimum Data Rate 250kbps
- Power Supply Range Single +3.0V to +3.6V
- Low Supply Current in Power-down State 1µA
- Pb-Free (RoHS Compliant)

Applications

- Any System Requiring RS-232 Communication Ports
 - Battery Powered, Hand-Held, and Portable Equipment
 - Laptop Computers, Notebooks, Palmtops
 - Modems, Printers and other Peripherals
 - Digital Cameras
 - Cellular/Mobile Phones

TABLE 1. SUMMARY OF FEATURES

PART NUMBER	NUMBER OF Tx	NUMBER OF Rx	DATA RATE (kbps)	RECEIVER ENABLE FUNCTION?	READY OUTPUT?	MANUAL POWER-DOWN?	AUTOMATIC POWER-DOWN FUNCTION?
ICL3221EM	1	1	250	Yes	No	Yes	Yes

Ordering Information

PART NUMBER	PART MARKING	TEMP RANGE (°C)	PACKAGE	PKG. DWG. #
ICL3221EMVZ* (Notes 1, 2, 3)	3221 EMVZ	-55 to +125	16 Ld TSSOP	M16.173

NOTES:

1. Add "-T" suffix for tape and reel. Please refer to [TB347](#) for details on reel specifications.
2. These Intersil Pb-free plastic packaged products employ special Pb-free material sets, molding compounds/die attach materials, and 100% matte tin plate plus anneal (e3 termination finish, which is RoHS compliant and compatible with both SnPb and Pb-free soldering operations). Intersil Pb-free products are MSL classified at Pb-free peak reflow temperatures that meet or exceed the Pb-free requirements of IPC/JEDEC J STD-020.
3. For Moisture Sensitivity Level (MSL), please see device information page for [ICL3221EM](#). For more information on MSL please see techbrief [TB363](#).

Pin Configurations

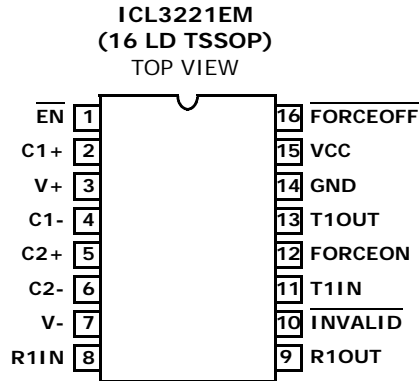

Pin Descriptions

PIN	PIN NUMBER	FUNCTION
$\overline{\text{EN}}$	1	Active low receiver enable control
C1+	2	External capacitor (voltage doubler) is connected to this lead.
V+	3	Internally generated positive transmitter supply (+5.5V).
C1-	4	External capacitor (voltage doubler) is connected to this lead.
C2+	5	External capacitor (voltage inverter) is connected to this lead.
C2-	6	External capacitor (voltage inverter) is connected to this lead.
V-	7	Internally generated negative transmitter supply (-5.5V).
R1IN	8	$\pm 15\text{kV}$ ESD Protected, RS-232 compatible receiver inputs.
R1OUT	9	TTL/CMOS level receiver outputs.
$\overline{\text{INVALID}}$	10	Active low output that indicates if no valid RS-232 levels are present on any receiver input.
T1IN	11	TTL/CMOS compatible transmitter Inputs.
FORCEON	12	Active high input to override automatic power-down circuitry thereby keeping transmitters active (FORCEOFF must be high).
T1OUT	13	$\pm 15\text{kV}$ ESD Protected, RS-232 level (nominally $\pm 5.5\text{V}$) transmitter outputs.
GND	14	Ground connection.
VCC	15	System power supply input (3.0V to 3.6V).
$\overline{\text{FORCEOFF}}$	16	Active low to shut down transmitters and on-chip power supply. This overrides any automatic circuitry and FORCEON (see Table 2).

Typical Operating Circuits

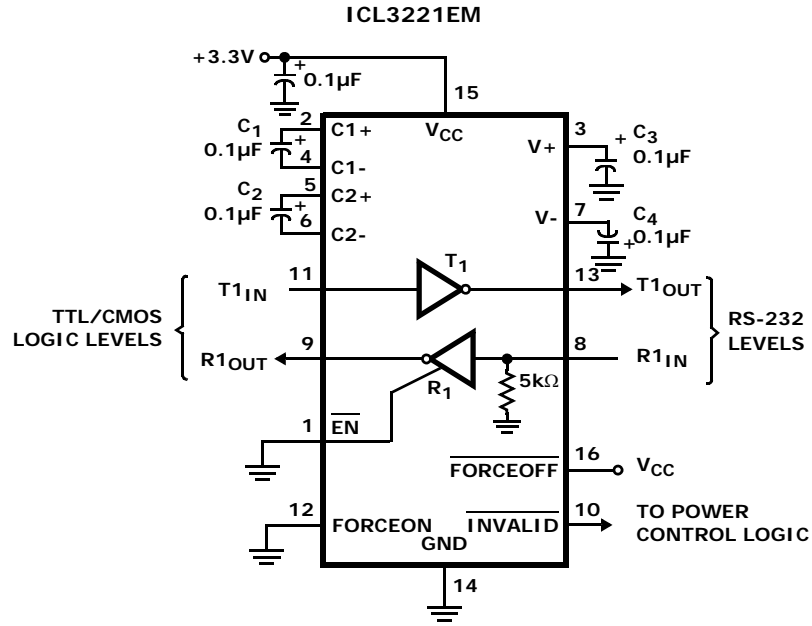

ISL3221EM

Absolute Maximum Ratings

V _{CC} to GND	-0.3V to 6V
V ₊ to GND	-0.3V to 7V
V ₋ to GND	+0.3V to -7V
V ₊ to V ₋	14V
Input Voltages	
T _{IN} , FORCEOFF, FORCEON, $\overline{\text{EN}}$, $\overline{\text{SHDN}}$	-0.3V to 6V
R _{IN}	±25V
Output Voltages	
T _{OUT}	±13.2V
R _{OUT} , INVALID	-0.3V to V _{CC} + 0.3V
Short Circuit Duration	
T _{OUT}	Continuous
ESD Rating	See Specification Table on page 5

Thermal Information

Thermal Resistance (Typical, Note 4)	θ_{JA} (°C/W)
16 Ld TSSOP Package	145
Maximum Junction Temperature (Plastic Package)	+150°C
Maximum Storage Temperature Range	-65°C to +150°C
Pb-Free Reflow Profile	see link below
	http://www.intersil.com/pbfree/Pb-FreeReflow.asp

Operating Conditions

Operating Voltage Range	+3.0V to +3.6V
Temperature Range	-55°C to +125°C

CAUTION: Do not operate at or near the maximum ratings listed for extended periods of time. Exposure to such conditions may adversely impact product reliability and result in failures not covered by warranty.

NOTE:

- θ_{JA} is measured with the component mounted on a low effective thermal conductivity test board in free air. See Tech Brief TB379 for details.

Electrical Specifications Test Conditions: V_{CC} = 3.3V ±10%, C₁ - C₄ = 0.1µF; Unless Otherwise Specified. Typical values are at T_A = +25°C. **Boldface limits apply over the operating temperature range, -55°C to +125°C.**

PARAMETER	TEST CONDITIONS	TEMP (°C)	MIN (Note 6)	TYP	MAX (Note 6)	UNITS
DC CHARACTERISTICS						
Supply Current, Automatic Power-down	All R _{IN} Open, FORCEON = GND, $\overline{\text{FORCEOFF}} = V_{CC}$	Full	-	1.0	10	µA
Supply Current, Power-down	$\overline{\text{FORCEOFF}} = \overline{\text{SHDN}} = \text{GND}$	Full	-	1.0	10	µA
Supply Current, Automatic Power-down Disabled	All Outputs Unloaded, FORCEON = $\overline{\text{FORCEOFF}} = \overline{\text{SHDN}} = V_{CC}$	Full	-	0.3	1.8	mA
LOGIC AND TRANSMITTER INPUTS AND RECEIVER OUTPUTS						
Input Logic Threshold Low	T _{IN} , FORCEON, $\overline{\text{FORCEOFF}}$, $\overline{\text{EN}}$, $\overline{\text{SHDN}}$	Full	-	-	0.8	V
Input Logic Threshold High	T _{IN} , FORCEON, $\overline{\text{FORCEOFF}}$, $\overline{\text{EN}}$, $\overline{\text{SHDN}}$	Full	2.0	-	-	V
Input Leakage Current	T _{IN} , FORCEON, $\overline{\text{FORCEOFF}}$, $\overline{\text{EN}}$, $\overline{\text{SHDN}}$	Full	-	±0.01	± 10	µA
Output Leakage Current	$\overline{\text{FORCEOFF}} = \text{GND}$ or $\overline{\text{EN}} = V_{CC}$	Full	-	±0.05	± 10	µA
Output Voltage Low	I _{OUT} = 1.6mA	Full	-	-	0.4	V
Output Voltage High	I _{OUT} = -1.0mA	Full	V_{CC} - 0.6	V _{CC} - 0.1	-	V
AUTOMATIC POWER-DOWN (FORCEON = GND, $\overline{\text{FORCEOFF}} = V_{CC}$)						
Receiver Input Thresholds to Enable Transmitters	Power Up (see Figure 6)	Full	-2.7	-	2.7	V
Receiver Input Thresholds to Disable Transmitters	Power Down (see Figure 6)	Full	-0.3	-	0.3	V
INVALID Output Voltage Low	I _{OUT} = 1.6mA	Full	-	-	0.4	V
INVALID Output Voltage High	I _{OUT} = -1.0mA	Full	V_{CC} - 0.6	-	-	V
Receiver Threshold to Transmitters Enabled Delay (t _{WU})		25	-	100	-	µs
Receiver Positive or Negative Threshold to INVALID High Delay (t _{IN VH})		25	-	1	-	µs

ISL3221EM

Electrical Specifications Test Conditions: $V_{CC} = 3.3V \pm 10\%$, $C_1 - C_4 = 0.1\mu F$; Unless Otherwise Specified. Typical values are at $T_A = +25^\circ C$. **Boldface limits apply over the operating temperature range, $-55^\circ C$ to $+125^\circ C$.** (Continued)

PARAMETER	TEST CONDITIONS	TEMP (°C)	MIN (Note 6)	TYP	MAX (Note 6)	UNITS	
Receiver Positive or Negative Threshold to INVALID Low Delay (t_{1NVL})		25	-	30	-	μs	
RECEIVER INPUT							
Input Voltage Range		25	-25	-	25	V	
Input Threshold Low	$V_{CC} = 3.3V$	25	0.6	1.2	-	V	
Input Threshold High	$V_{CC} = 3.3V$	25	-	1.5	2.4	V	
Input Hysteresis		25	-	0.5	-	V	
Input Resistance		25	3	5	7	k Ω	
TRANSMITTER OUTPUT							
Output Voltage Swing	All Transmitter Outputs Loaded with 3k Ω to Ground	Full	± 5.0	± 5.4	-	V	
Output Resistance	$V_{CC} = V_+ = V_- = 0V$, Transmitter Output = $\pm 2V$	Full	300	10M	-	Ω	
Output Short-Circuit Current		Full	-	± 35	± 60	mA	
Output Leakage Current	$V_{OUT} = \pm 12V$, $V_{CC} = 0V$ or $3V$ to $3.6V$, Automatic Power-down or $FORCEOFF = SHDN = GND$	Full	-	-	± 25	μA	
TIMING CHARACTERISTICS							
Maximum Data Rate	$R_L = 3k\Omega$, $C_L = 1000pF$, One Transmitter Switching	Full	250	500	-	kbps	
Receiver Propagation Delay	Receiver Input to Receiver Output, $C_L = 150pF$	t_{PHL}	25	-	0.15	-	μs
		t_{PLH}	25	-	0.15	-	μs
Receiver Output Enable Time	Normal Operation	25	-	200	-	ns	
Receiver Output Disable Time	Normal Operation	25	-	200	-	ns	
Transmitter Skew	t_{PHL} to t_{PLH} (Note 5)	25	-	100	1000	ns	
Receiver Skew	t_{PHL} to t_{PLH}	25	-	50	1000	ns	
Transition Region Slew Rate	$V_{CC} = 3.3V$, $R_L = 3k\Omega$ to $7k\Omega$, Measured from $3V$ to $-3V$ or $-3V$ to $3V$	$C_L = 150pF$ to $2500pF$	25	4	-	30	V/ μs
		$C_L = 150pF$ to $1000pF$	25	6	-	30	V/ μs
ESD PERFORMANCE							
RS-232 Pins (TOUT, RIN)	Human Body Model	25	-	± 15	-	kV	
	IEC61000-4-2 Contact Discharge	25	-	± 8	-	kV	
	IEC61000-4-2 Air Gap Discharge	25	-	± 15	-	kV	
All Other Pins	Human Body Model	25	-	± 2	-	kV	

NOTES:

- Transmitter skew is measured at the transmitter zero crossing points.
- Parts are 100% tested at $+25^\circ C$. Full temp limits are guaranteed by bench and tester characterization

Detailed Description

ICL3221EM interface ICs operate from a single +3V supply, guarantee a 250kbps minimum data rate, require only four small external 0.1µF capacitors, feature low power consumption, and meet all EIA RS-232C and V.28 specifications. The circuit is divided into three sections: charge pump, transmitters and receivers.

Charge-Pump

Intersil's ICL3221EM utilizes regulated on-chip dual charge pumps as voltage doublers, and voltage inverters to generate ±5.5V transmitter supplies from a V_{CC} supply as low as 3.0V. This allows these devices to maintain RS-232 compliant output levels over the ±10% tolerance range of 3.3V powered systems. The efficient on-chip power supplies require only four small, external 0.1µF capacitors for the voltage doubler and inverter functions at V_{CC} = 3.3V. See "Capacitor Selection" on page 9 and Table 3 on page 9 for capacitor recommendations for other operating conditions. The charge pumps operate discontinuously (i.e., they turn off as soon as the V+ and V- supplies are pumped up to the nominal values), resulting in significant power savings.

Transmitters

The transmitters are proprietary, low dropout, inverting drivers that translate TTL/CMOS inputs to EIA/TIA-232 output levels. Coupled with the on-chip ±5.5V supplies, these transmitters deliver true RS-232 levels over a wide range of single supply system voltages.

The transmitter output disables and assumes a high impedance state when the device enters the power-down mode (see Table 2). These outputs may be driven to ±12V when disabled.

All devices guarantee a 250kbps data rate for full load conditions (3kΩ and 1000pF), V_{CC} ≥ 3.0V, with one transmitter operating at full speed. Under more typical conditions of V_{CC} ≥ 3.3V, R_L = 3kΩ, and C_L = 250pF, one transmitter easily operates at 900kbps.

Transmitter inputs float if left unconnected, and may cause I_{CC} increases. Connect unused inputs to GND for the best performance.

Receivers

The ICL3221EM device contains standard inverting receiver that three-state via the EN or FORCEOFF control lines. The receivers convert RS-232 signals to CMOS output levels and accept inputs up to ±25V while presenting the required 3kΩ to 7kΩ input impedance (see Figure 1) even if the power is off (V_{CC} = 0V). The receivers' Schmitt trigger input stage uses hysteresis to increase noise immunity and decrease errors due to slow input signal transitions.

The ICL3221EM's inverting receiver is disabled only when EN is driven high (see Table 2).

Standard receivers driving powered down peripherals must be disabled to prevent current flow through the peripheral's protection diodes (see Figures 2 and 3).

This renders them useless for wake up functions, but the corresponding monitor receiver can be dedicated to this task as shown in Figure 3.

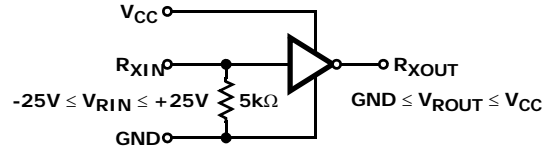

FIGURE 1. INVERTING RECEIVER CONNECTIONS

Low Power Operation

These 3V devices require a nominal supply current of 0.3mA, during normal operation (not in power-down mode). This is considerably less than the 5mA to 11mA current required by comparable 5V RS-232 devices, allowing users to reduce system power simply by switching to this new family.

Pin Compatible Replacements for 5V Devices

The ICL3221EM is pin compatible with existing 5V RS-232 transceivers - See the "Features" section on page 1 for details.

This pin compatibility coupled with the low I_{CC} and wide operating supply range, make the ICL3221EM potential lower power, higher performance drop-in replacements for existing 5V applications. As long as the ±5V RS-232 output swings are acceptable, and transmitter input pull-up resistors aren't required, the ICL3221EM should work in most 5V applications.

When replacing a device in an existing 5V application, it is acceptable to terminate C₃ to V_{CC} as shown on the "Typical Operating Circuits" on page 3. Nevertheless, terminate C₃ to GND if possible, as slightly better performance results from this configuration.

Power-down Functionality

The already low current requirement drops significantly when the device enters power-down mode. In power-down, supply current drops to 1µA, because the on-chip charge pump turns off (V+ collapses to V_{CC}, V- collapses to GND), and the transmitter outputs three-state. Inverting receiver outputs may or may not disable in power-down; refer to Table 2 for details. This micro-power mode makes these devices ideal for battery powered and portable applications.

Software Controlled (Manual) Power-down

The ICL3221EM device provides a pin that allows the user to force the IC into the low power, standby state. Driving this pin high enables normal operation, while driving it low forces the IC into its power-down state. Connect SHDN to V_{CC} if the power-down function isn't needed. Note that all the receiver outputs remain enabled during shutdown (see Table 2). For the lowest power consumption during power-down, the receivers should also be disabled by driving the EN input high (see next section, and Figures 2 and 3).

ISL3221EM

TABLE 2. POWER-DOWN AND ENABLE LOGIC TRUTH TABLE

RS-232 SIGNAL PRESENT AT RECEIVER INPUT?	FORCEOFF OR SHDN INPUT	FORCEON INPUT	$\overline{\text{EN}}$ INPUT	TRANSMITTER OUTPUTS	RECEIVER OUTPUTS	$\overline{\text{INVALID}}$ OUTPUT	MODE OF OPERATION
ICL3221EM							
No	H	H	L	Active	Active	L	Normal Operation (Auto Power-down Disabled)
No	H	H	H	Active	High-Z	L	
Yes	H	L	L	Active	Active	H	Normal Operation (Auto Power-down Enabled)
Yes	H	L	H	Active	High-Z	H	
No	H	L	L	High-Z	Active	L	Power-down Due to Auto Power-down Logic
No	H	L	H	High-Z	High-Z	L	
Yes	L	X	L	High-Z	Active	H	Manual Power-down
Yes	L	X	H	High-Z	High-Z	H	Manual Power-down with Receiver Disabled
No	L	X	L	High-Z	Active	L	Manual Power-down
No	L	X	H	High-Z	High-Z	L	Manual Power-down with Receiver Disabled

The ICL3221EM utilizes a two pin approach where the FORCEON and $\overline{\text{FORCEOFF}}$ inputs determine the IC's mode. For always enabled operation, FORCEON and FORCEOFF are both strapped high. To switch between active and power-down modes, under logic or software control, only the $\overline{\text{FORCEOFF}}$ input need be driven. The FORCEON state isn't critical, as $\overline{\text{FORCEOFF}}$ dominates over FORCEON. Nevertheless, if strictly manual control over power-down is desired, the user must strap FORCEON high to disable the automatic power-down circuitry.

The $\overline{\text{INVALID}}$ output always indicates whether or not a valid RS-232 signal is present at any of the receiver inputs (see Table 2), giving the user an easy way to determine when the interface block should power down. In the case of a disconnected interface cable where all the receiver inputs are floating (but pulled to GND by the internal receiver pull down resistors), the $\overline{\text{INVALID}}$ logic detects the invalid levels and drives the output low. The power management logic then uses this indicator to power down the interface block. Reconnecting the cable restores valid levels at the receiver inputs, $\overline{\text{INVALID}}$ switches high, and the power management logic wakes up the interface block. $\overline{\text{INVALID}}$ can also be used to indicate the DTR or RING INDICATOR signal, as long as the other receiver inputs are floating, or driven to GND (as in the case of a powered down driver). Connecting FORCEOFF and FORCEON together disables the automatic power-down feature, enabling them to function as a manual SHUTDOWN input (see Figure 4).

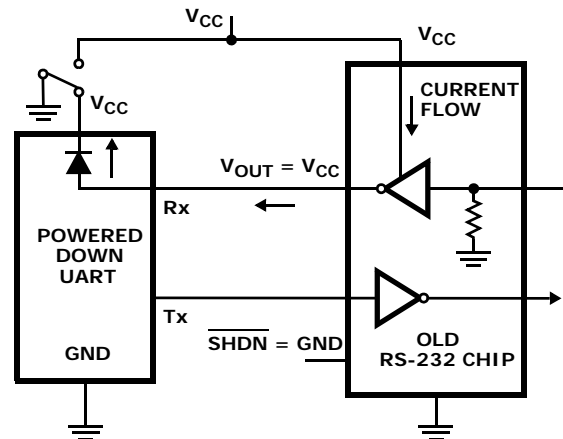

FIGURE 2. POWER DRAIN THROUGH POWERED DOWN PERIPHERAL

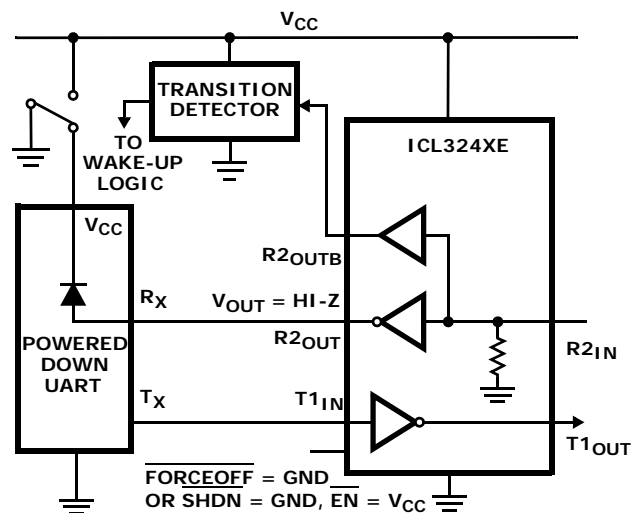

FIGURE 3. DISABLED RECEIVERS PREVENT POWER DRAIN

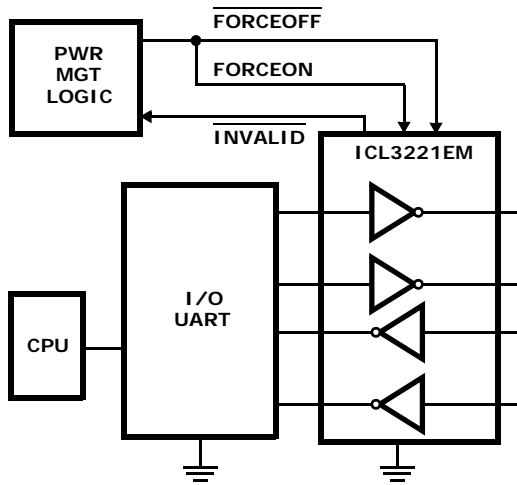

FIGURE 4. CONNECTIONS FOR MANUAL POWER-DOWN WHEN NO VALID RECEIVER SIGNALS ARE PRESENT

With any of the control schemes, the time required to exit power-down, and resume transmission is only 100µs. A mouse, or other application, may need more time to wake up from shutdown. If automatic power-down is being utilized, the RS-232 device will reenter power-down if valid receiver levels aren't reestablished within 30µs of the ICL3221EM powering up. Figure 5 illustrates a circuit that keeps the ICL3221EM from initiating automatic power-down for 100ms after powering up. This gives the slow-to-wake peripheral circuit time to reestablish valid RS-232 output levels.

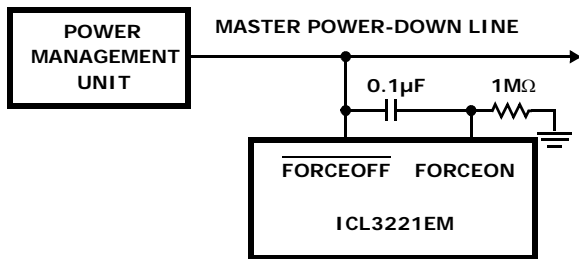

FIGURE 5. CIRCUIT TO PREVENT AUTO POWER-DOWN FOR 100ms AFTER FORCED POWER-UP

Automatic Power-down

Even greater power savings is available by using the devices which feature an automatic power-down function. When no valid RS-232 voltages (see Figure 6) are sensed on any receiver input for 30µs, the charge pump and transmitters power-down, thereby reducing supply current to 1µA. Invalid receiver levels occur whenever the driving peripheral's outputs are shut off (powered down) or when the RS-232 interface cable is disconnected. The ICL3221EM powers back up whenever it detects a valid RS-232 voltage level on any receiver input. This automatic power-down feature provides additional system power savings without changes to the existing operating system.

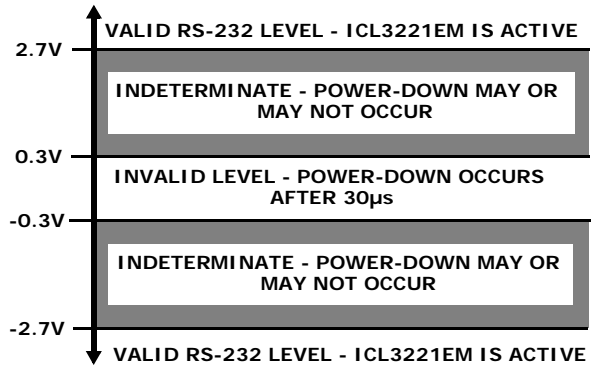

FIGURE 6. DEFINITION OF VALID RS-232 RECEIVER LEVELS

Automatic power-down operates when the FORCEON input is low, and the FORCEOFF input is high. Tying FORCEON high disables automatic power-down, but manual power-down is always available via the overriding FORCEOFF input. Table 2 summarizes the automatic power-down functionality.

Devices with the automatic power-down feature include an INVALID output signal, which switches low to indicate that invalid levels have persisted on all of the receiver inputs for more than 30µs (see Figure 7). INVALID switches high 1µs after detecting a valid RS-232 level on a receiver input. INVALID operates in all modes (forced or automatic power-down, or forced on), so it is also useful for systems employing manual power-down circuitry. When automatic power-down is utilized, INVALID = 0 indicates that the ICL3221EM is in power-down mode.

The time to recover from automatic power-down mode is typically 100µs.

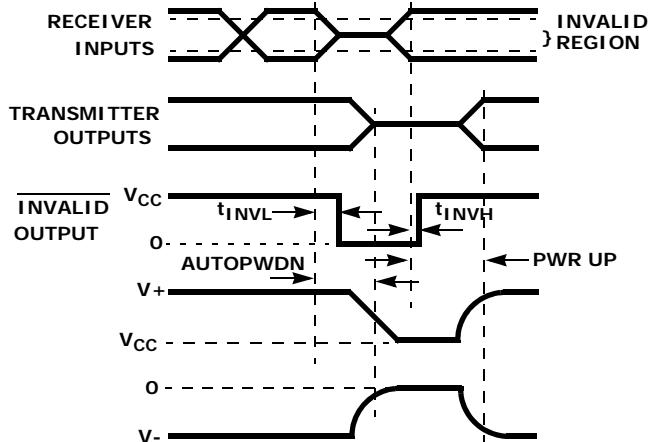

FIGURE 7. AUTOMATIC POWER-DOWN AND INVALID TIMING DIAGRAMS

Receiver ENABLE Control

Several devices also feature an EN input to control the receiver outputs. Driving EN high disables all the inverting (standard) receiver outputs placing them in a

high impedance state. This is useful to eliminate supply current, due to a receiver output forward biasing the protection diode, when driving the input of a powered down ($V_{CC} = GND$) peripheral (see Figure 2).

Capacitor Selection

The charge pumps require 0.1 μ F capacitors for 3.3V operation. For other supply voltages, refer to Table 3 for capacitor values. Do not use values smaller than those listed in Table 3. Increasing the capacitor values (by a factor of 2) reduces ripple on the transmitter outputs and slightly reduces power consumption. C_2 , C_3 , and C_4 can be increased without increasing C_1 's value, however, do not increase C_1 without also increasing C_2 , C_3 , and C_4 to maintain the proper ratios (C_1 to the other capacitors).

When using minimum required capacitor values, make sure that capacitor values do not degrade excessively with temperature. If in doubt, use capacitors with a larger nominal value. The capacitor's equivalent series resistance (ESR) usually rises at low temperatures and it influences the amount of ripple on $V+$ and $V-$.

TABLE 3. REQUIRED CAPACITOR VALUES

V_{CC} (V)	C_1 (μ F)	C_2, C_3, C_4 (μ F)
3.0 to 3.6	0.1	0.1

Power Supply Decoupling

In most circumstances a 0.1 μ F bypass capacitor is adequate. In applications that are particularly sensitive to power supply noise, decouple V_{CC} to ground with a capacitor of the same value as the charge-pump capacitor C_1 . Connect the bypass capacitor as close as possible to the IC.

Operation Down to 2.7V

The ICL3221EM transmitter outputs meet RS-562 levels ($\pm 3.7V$), at full data rate, with V_{CC} as low as 2.7V. RS-562 levels typically ensure interoperability with RS-232 devices.

Transmitter Outputs when Exiting Power-down

Figure 8 shows the response of two transmitter outputs when exiting power-down mode. As they activate, the two transmitter outputs properly go to opposite RS-232 levels, with no glitching, ringing, nor undesirable transients. Each transmitter is loaded with 3k Ω in parallel with 2500pF. Note that the transmitters enable only when the magnitude of the supplies exceed approximately 3V.

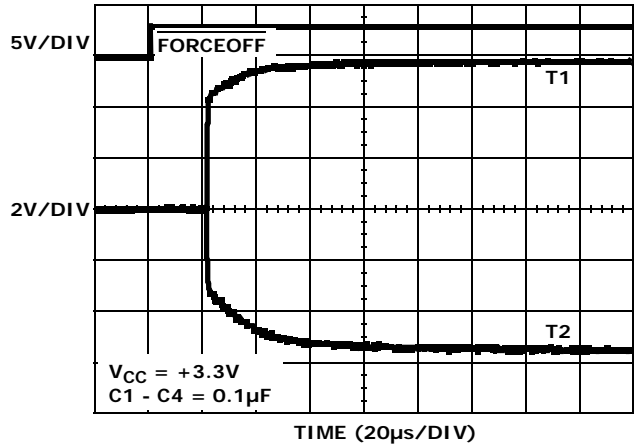

FIGURE 8. TRANSMITTER OUTPUTS WHEN EXITING POWER-DOWN

High Data Rates

The ICL3221EM maintains the RS-232 $\pm 5V$ minimum transmitter output voltages even at high data rates. Figure 9 details a transmitter loopback test circuit, and Figure 10 illustrates the loopback test result at 120kbps. For this test, all transmitters were simultaneously driving RS-232 loads in parallel with 1000pF, at 120kbps. Figure 11 shows the loopback results for a single transmitter driving 1000pF and an RS-232 load at 250kbps. The static transmitters were also loaded with an RS-232 receiver.

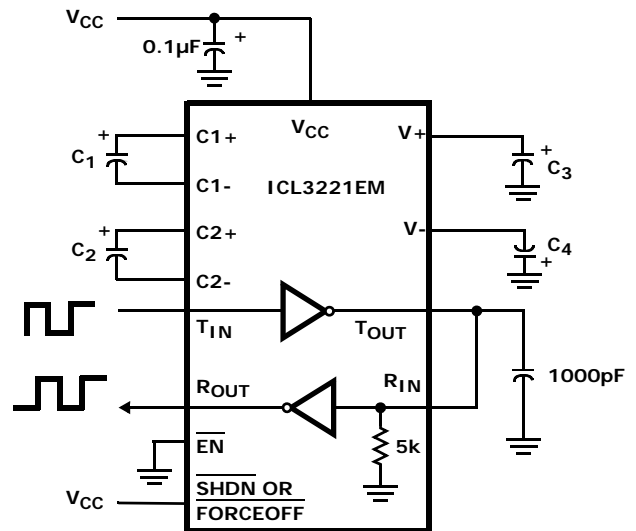

FIGURE 9. TRANSMITTER LOOPBACK TEST CIRCUIT

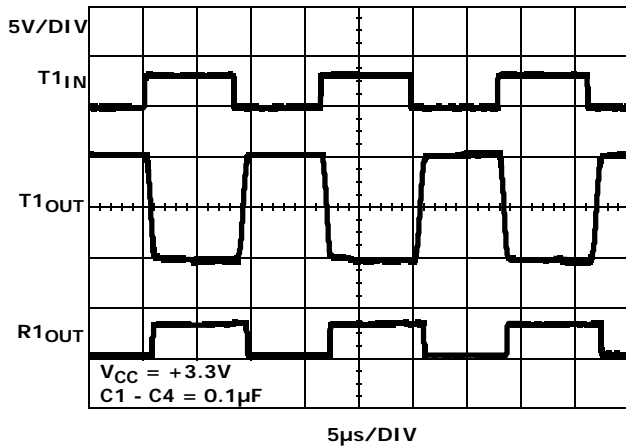

FIGURE 10. LOOPBACK TEST AT 120kbps

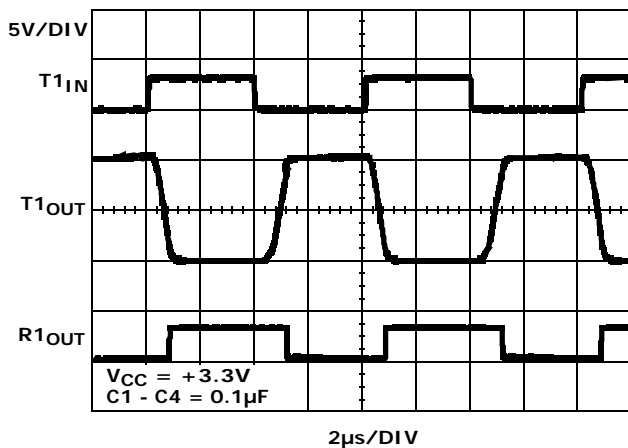

FIGURE 11. LOOPBACK TEST AT 250kbps

Interconnection with 3V and 5V Logic

The ICL3221EM directly interfaces with 5V CMOS and TTL logic families. Nevertheless, with the ICL3221EM at 3.3V, and the logic supply at 5V, AC, HC, and CD4000 outputs can drive ICL3221EM inputs, but ICL3221EM outputs do not reach the minimum V_{IH} for these logic families. See Table 4 for more information.

TABLE 4. LOGIC FAMILY COMPATIBILITY WITH VARIOUS SUPPLY VOLTAGES

SYSTEM POWER-SUPPLY VOLTAGE (V)	V _{CC} SUPPLY VOLTAGE (V)	COMPATIBILITY
3.3	3.3	Compatible with all CMOS families.

± 15kV ESD Protection

All pins on ICL3221EM devices include ESD protection structures, but the ICL3221EM family incorporates advanced structures which allow the RS-232 pins (transmitter outputs and receiver inputs) to survive ESD events up to ±15kV. The RS-232 pins are particularly vulnerable to ESD damage because they typically connect to an exposed port on the exterior of the finished product. Simply touching the port pins, or connecting a cable, can cause an ESD event that might destroy unprotected ICs. These new ESD structures protect the device whether or not it is powered up, protect without allowing any latch-up mechanism to activate, and don't interfere with RS-232 signals as large as ±25V.

Human Body Model (HBM) Testing

As the name implies, this test method emulates the ESD event delivered to an IC during human handling. The tester delivers the charge through a 1.5kΩ current limiting resistor, making the test less severe than the IEC61000 test, which utilizes a 330Ω limiting resistor. The HBM method determines an IC's ability to withstand the ESD transients typically present during handling and manufacturing. Due to the random nature of these events, each pin is tested with respect to all other pins. The RS-232 pins on "E" family devices can withstand HBM ESD events to ±15kV.

IEC61000-4-2 Testing

The IEC61000 test method applies to finished equipment, rather than to an individual IC. Therefore, the pins most likely to suffer an ESD event are those that are exposed to the outside world (the RS-232 pins in this case), and the IC is tested in its typical application configuration (power applied) rather than testing each pin-to-pin combination. The lower current limiting resistor coupled with the larger charge storage capacitor yields a test that is much more severe than the HBM test. The extra ESD protection built into this device's RS-232 pins allows the design of equipment meeting level 4 criteria without the need for additional board level protection on the RS-232 port.

AIR-GAP DISCHARGE TEST METHOD

For this test method, a charged probe tip moves toward the IC pin until the voltage arcs to it. The current waveform delivered to the IC pin depends on approach speed, humidity, temperature, etc., so it is difficult to obtain repeatable results. The "E" device RS-232 pins withstand ±15kV air-gap discharges.

CONTACT DISCHARGE TEST METHOD

During the contact discharge test, the probe contacts the tested pin before the probe tip is energized, thereby eliminating the variables associated with the air-gap discharge. The result is a more repeatable and predictable test, but equipment limits prevent testing devices at voltages higher than ±8kV. All "E" family devices survive ±8kV contact discharges on the RS-232 pins.

Typical Performance Curves $V_{CC} = 3.3V, T_A = +25^\circ C.$

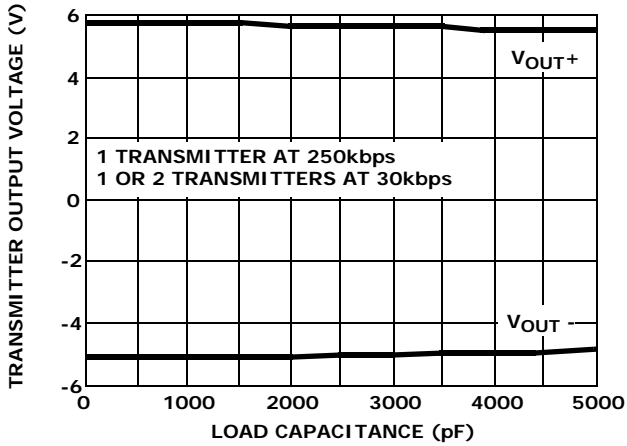

FIGURE 12. TRANSMITTER OUTPUT VOLTAGE vs LOAD CAPACITANCE

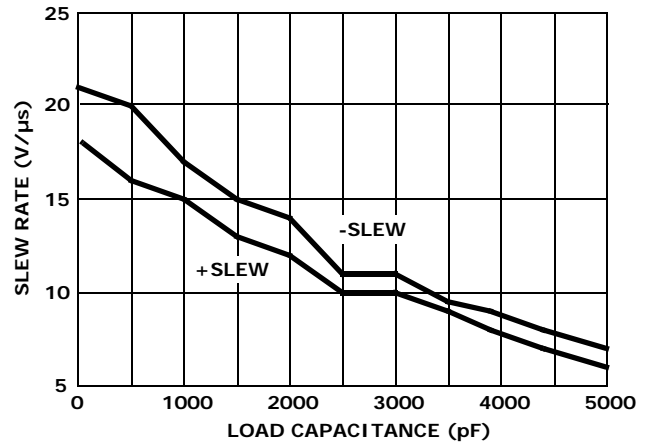

FIGURE 13. SLEW RATE vs LOAD CAPACITANCE

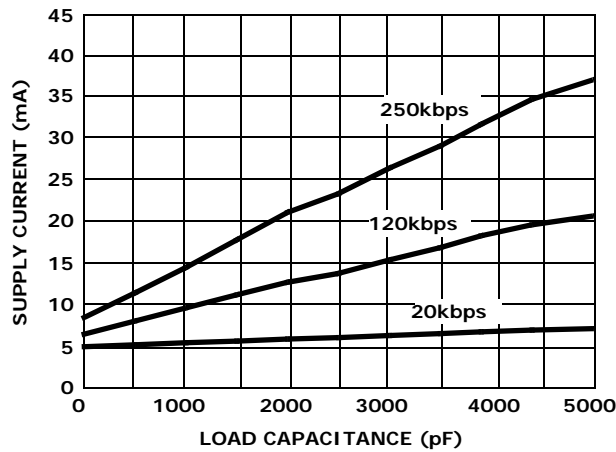

FIGURE 14. SUPPLY CURRENT vs LOAD CAPACITANCE WHEN TRANSMITTING DATA

Die Characteristics

SUBSTRATE POTENTIAL (POWERED UP):

GND

TRANSISTOR COUNT:

ISL3221EM: 286

PROCESS:

Si Gate CMOS

Thin Shrink Small Outline Plastic Packages (TSSOP)

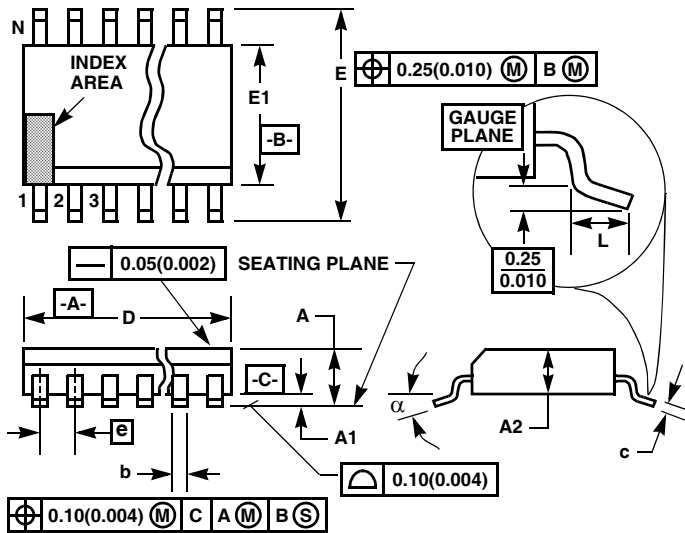

M16.173
16 LEAD THIN SHRINK SMALL OUTLINE PLASTIC PACKAGE

SYMBOL	INCHES		MILLIMETERS		NOTES
	MIN	MAX	MIN	MAX	
A	-	0.043	-	1.10	-
A1	0.002	0.006	0.05	0.15	-
A2	0.033	0.037	0.85	0.95	-
b	0.0075	0.012	0.19	0.30	9
c	0.0035	0.008	0.09	0.20	-
D	0.193	0.201	4.90	5.10	3
E1	0.169	0.177	4.30	4.50	4
e	0.026 BSC		0.65 BSC		-
E	0.246	0.256	6.25	6.50	-
L	0.020	0.028	0.50	0.70	6
N	16		16		7
α	0°	8°	0°	8°	-

NOTES:

1. These package dimensions are within allowable dimensions of JEDEC MO-153-AB, Issue E.
2. Dimensioning and tolerancing per ANSI Y14.5M-1982.
3. Dimension "D" does not include mold flash, protrusions or gate burrs. Mold flash, protrusion and gate burrs shall not exceed 0.15mm (0.006 inch) per side.
4. Dimension "E1" does not include interlead flash or protrusions. Interlead flash and protrusions shall not exceed 0.15mm (0.006 inch) per side.
5. The chamfer on the body is optional. If it is not present, a visual index feature must be located within the crosshatched area.
6. "L" is the length of terminal for soldering to a substrate.
7. "N" is the number of terminal positions.
8. Terminal numbers are shown for reference only.
9. Dimension "b" does not include dambar protrusion. Allowable dambar protrusion shall be 0.08mm (0.003 inch) total in excess of "b" dimension at maximum material condition. Minimum space between protrusion and adjacent lead is 0.07mm (0.0027 inch).
10. Controlling dimension: MILLIMETER. Converted inch dimensions are not necessarily exact. (Angles in degrees)

Rev. 1 2/02

For additional products, see www.intersil.com/product_tree

Intersil products are manufactured, assembled and tested utilizing ISO9000 quality systems as noted in the quality certifications found at www.intersil.com/design/quality

Intersil products are sold by description only. Intersil Corporation reserves the right to make changes in circuit design, software and/or specifications at any time without notice. Accordingly, the reader is cautioned to verify that data sheets are current before placing orders. Information furnished by Intersil is believed to be accurate and reliable. However, no responsibility is assumed by Intersil or its subsidiaries for its use; nor for any infringements of patents or other rights of third parties which may result from its use. No license is granted by implication or otherwise under any patent or patent rights of Intersil or its subsidiaries.

For information regarding Intersil Corporation and its products, see www.intersil.com