

.100" (2.54 mm) Card Edge Crimp Connector

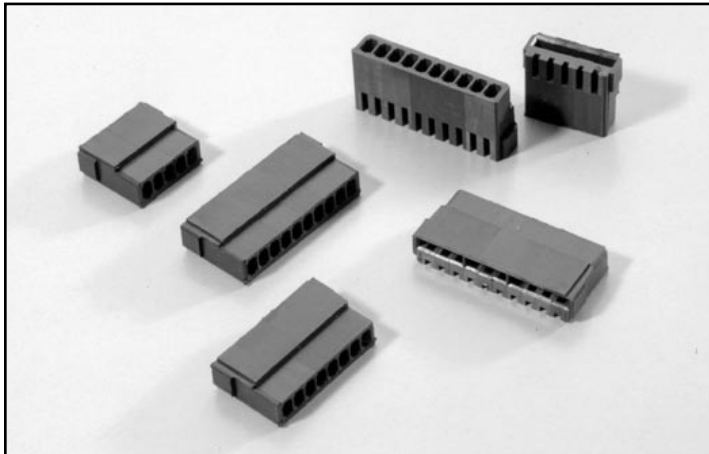

1500 SERIES

PART NUMBER LEGEND

1500-XX-02-X

DENOTES CUSTOM KEY LOCATION
(SEE TABLE FOR LOCATION)

NUMBER OF POSITIONS (SEE TABLE I)

Mating Crimp Contact: 14XX-1XX Series

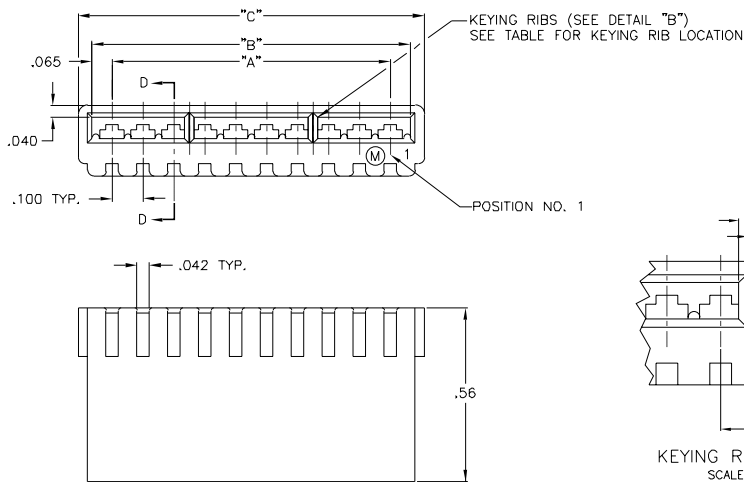

NOTES:

- THIS PART FOR USE WITH A .062±.007 P.C. BOARD (SINGLE SIDED)
- CRIMP TERMINAL SHOWN (P/N 1400-2XX) FOR USE WITH 22 AWG THRU 30 AWG WIRE.
- HOUSING MATERIAL: POLYESTER, 15% G.F., UL94V0
COLOR: BLACK

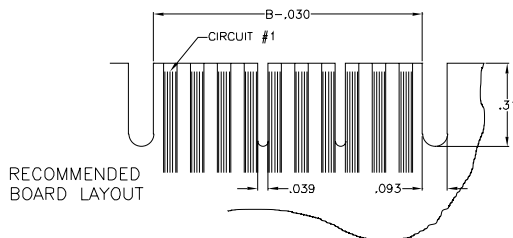
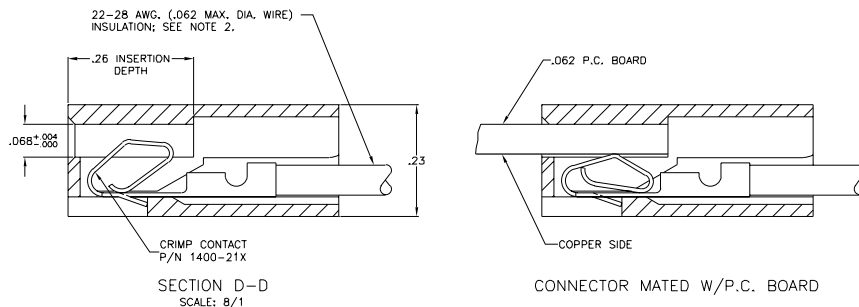

TABLE 1

PART No.	DIM "A"	DIM "B" ±.010	DIM "C"	KEYING RIB BETWEEN CKTS
1500-02-02	.100 ±.004	.230	.320 ±.007	-
-03-	.200 ±.005	.330	.420 ±.007	-
-04-	.300 ±.005	.430	.520 ±.007	-
-05-	.400 ±.005	.530	.620 ±.008	-
-06-	.500 ±.006	.630	.720 ±.008	-
-07-	.600 ±.006	.730	.820 ±.008	-
-08-	.700 ±.006	.830	.920 ±.008	-
-09-	.800 ±.006	.930	1.020 ±.010	4&5
-10-	.900 ±.006	1.030	1.120 ±.010	4&5 7&8
-11-	1.000 ±.007	1.130	1.220 ±.010	4&5 8&9
-12-	1.100 ±.007	1.230	1.320 ±.010	4&5 9&10
-13-	1.200 ±.007	1.330	1.420 ±.010	4&5 8&9
-14-	1.300 ±.007	1.430	1.520 ±.010	4&5 8&9
-15-	1.400 ±.008	1.530	1.620 ±.010	4&5 8&9
-16-	1.500 ±.008	1.630	1.720 ±.012	4&5 8&9
-17-	1.600 ±.008	1.730	1.820 ±.012	4&5 8&9
-18-	1.700 ±.008	1.830	1.920 ±.012	4&5 8&9
-19-	1.800 ±.008	1.930	2.020 ±.012	4&5 8&9
-20-	1.900 ±.008	2.030	2.120 ±.012	4&5 8&9
-21-	2.000 ±.009	2.130	2.220 ±.012	4&5 8&9
-22-	2.100 ±.009	2.230	2.320 ±.012	4&5 8&9
-23-	2.200 ±.009	2.330	2.420 ±.012	4&5 8&9
-24-	2.300 ±.007	2.430	2.520 ±.014	4&5 8&9
1500-25-02	2.400 ±.010	2.530	2.620 ±.014	4&5 8&9
1500-12-02-0	1.100 ±.007	1.230	1.320 ±.008	-
1500-11-02-1	1.000 ±.007	1.130	1.220 ±.008	4&5 7&8



North and South America:
Methode Electronics, Inc. Connector Products
 1700 Hicks Road • Rolling Meadows, IL 60008 USA
 847-392-3500 • Toll Free: 800-323-6864 • Fax: 847-392-9404
 Email: info@methode.com • Web: www.methode.com/connector/index.html

Europe:
Methode Electronics Ireland, Ltd.
 Unit H, Crossagalla Business Park, Ballysimon Rd. • Limerick, Ireland
 +353 (0) 61 401222 • Fax: +353 (0) 61 401942
 Email: info@methode.ie • Web: ireland.methode.com/main.html

Far East:
Methode Electronics Far East, Pte. Ltd.
 1 Tuas Lane, Jurong Town • Singapore 638610
 65-68615444 • Fax: 65-68614777
 Email: sales@methode.com.sg • Web: www.methode.com/mefe/index.html

.100" (2.54 mm) Card Edge Connector - IDC

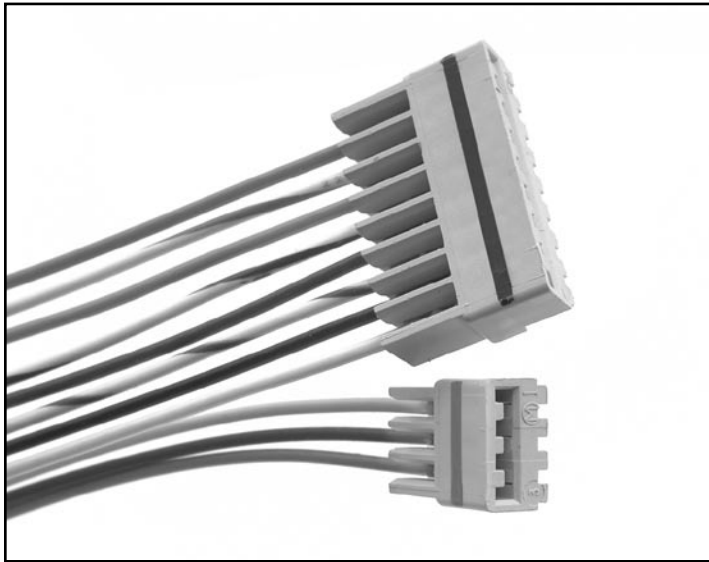

1500 SERIES

PART NUMBER LEGEND

150X-XX-1XX-XX

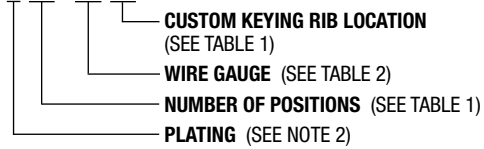

NOTES:

- MATERIAL:
INSULATOR - NYLON 6/6, 30% GLASS REINFORCED, UL94V-0
COLOR - WHITE
CONTACT - COPPER ALLOY
- FINISH: 1500 - .000150/.000250 90/10 TIN/LEAD
OVER .000050/.000150 NICKEL PLATE
1502 - .000015 GOLD OVER .000050/.000150 NICKEL PLATE
- POLARIZING RIBS CAN BE LOCATED BETWEEN ANY TWO CIRCUITS.
SEE TABLE 1 FOR STANDARD LOCATIONS.
- WIRE SIZE IN TABLE II APPLIES TO 7 STRAND CONDUCTORS.
- MAXIMUM INSULATION O.D. IS .060

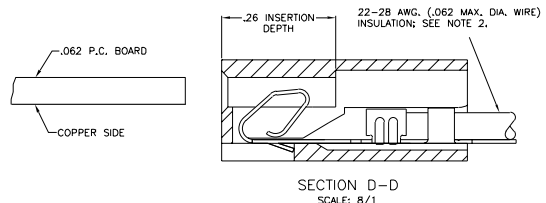
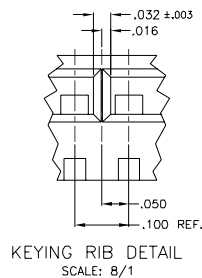
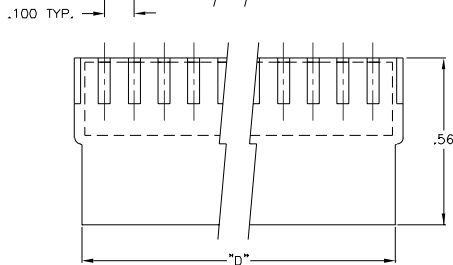
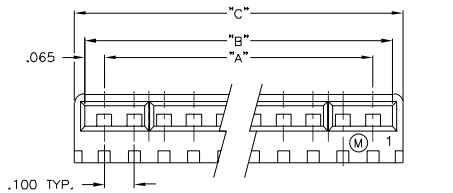

PART No.	WIRE SIZE	COLOR
1500-XX-122	22 AWG	RED
1500-XX-124	24 AWG	BLACK
1500-XX-126	26 AWG	BLUE
1500-XX-128	28 AWG	GREEN
1500-XX-130	30 AWG	WHITE

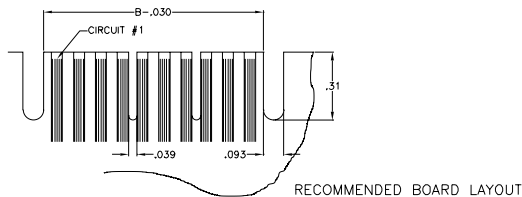
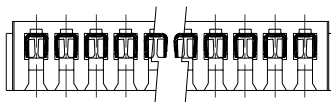

PART No.	CIRCUITS	DIM "A"	DIM "B"	DIM "C"	DIM "B"	KEYING RIB BETWEEN CKTS
1500-02-1XX	2	.100 ±.002	.230	.300 ±.008	.248	-
-03-	3	.200 ±.003	.330	.400 ±.008	.348	-
-04-	4	.300 ±.003	.430	.500 ±.008	.448	-
-05-	5	.400 ±.004	.530	.600 ±.008	.548	-
-06-	6	.500 ±.004	.630	.700 ±.008	.648	-
-07-	7	.600 ±.004	.730	.800 ±.008	.748	-
-08-	8	.700 ±.004	.830	.900 ±.008	.848	-
-09-	9	.800 ±.004	.930	1.000 ±.008	.948	4&5
-10-	10	.900 ±.004	1.030	1.100 ±.008	1.048	4&5 7&8
-11-	11	1.000 ±.007	1.130	1.200 ±.008	1.148	4&5 8&9
-12-	12	1.100 ±.007	1.230	1.300 ±.008	1.248	4&5 9&10
-13-	13	1.200 ±.007	1.330	1.400 ±.008	1.348	4&5 8&9
-14-	14	1.300 ±.007	1.430	1.500 ±.008	1.448	4&5 8&9
1500-15-1XX	15	1.400 ±.008	1.530	1.600 ±.008	1.548	4&5 8&9
1500-09-1XX-01	9	.800 ±.004	.930	1.000 ±.008	.948	2&3 6&7
1500-11-1XX-00	11	1.000 ±.005	1.130	1.200	1.148	-



North and South America:
Methode Electronics, Inc. Connector Products
 1700 Hicks Road • Rolling Meadows, IL 60008 USA
 847-392-3500 • Toll Free: 800-323-6864 • Fax: 847-392-9404
 Email: info@methode.com • Web: www.methode.com/connector/index.html

Europe:
Methode Electronics Ireland, Ltd.
 Unit H, Crossagalla Business Park, Ballysillon Rd. • Limerick, Ireland
 +353 (0) 61 401222 • Fax: +353 (0) 61 401942
 Email: info@methode.ie • Web: ireland.methode.com/main.html

Far East:
Methode Electronics Far East, Pte. Ltd.
 1 Tuas Lane, Jurong Town • Singapore 638610
 65-68615444 • Fax: 65-68614777
 Email: sales@methode.com.sg • Web: www.methode.com/mefe/index.html



Specifications

"TERMACON". Single Point Contact Connectors 1000, 1300 & 1500 Series Receptacles/Headers and Card Edge Connectors (.100" Centers)

Mechanical

1000 Series
.100" (2.54mm)

Insulator Housing: Nylon 94V-0 rated

Contact Material: Copper alloy tin plated

Insertion Force: Initial force to mate with .025 sq. pin - 8
ozs. max per circuit

Withdrawal Force: 2 oz. min. per circuit

Contact Retention: 6 lbs. min. in connector housing

Crimp Contact Insertion: 1.5 lbs. max. into connector
housing

Pin Push Out (Headers): 2 lbs. min.

Crimp Strength: Lead to terminal min. pull strength

Wire Gauge (AWG)	22	24	26	28	30
Pull (lbs.)	10	8	6	4	2

Electrical

High Voltage Dielectric: 1500 V RMS for 60 seconds
between adjacent terminals

Rated Voltage: 250 VAC

Current: .100" centers, 3.5 max.

Temperature Rise: 30°C at rated current

Terminal Resistance: Measured across a mated terminal
pair .100" centers, 10 mV at 1 amp

Ambient Temperature: -40°C to +105°C

Insulation Resistance: 500K Megohm min. between ad-
jacent contacts at 75°F and 50% RH

Humidity (MIL-STD-202E): After MIL-202E test has been
performed on mated terminal parts, maximum mV drop
should be two times the original mV reading prior to test
or .100" center, 25 mV at amp

Notes

Underwriters Laboratories Component Recognition File
E-48567

Canadian Standards File 52212



North and South America:

Methode Electronics, Inc. Connector Products

1700 Hicks Road • Rolling Meadows, IL 60008 USA

847-392-3500 • Toll Free: 800-323-6864 • Fax: 847-392-9404

Email: info@methode.com • Web: www.methode.com/connector/index.html

Europe:

Methode Electronics Ireland, Ltd.

Unit H, Crossagalla Business Park, Ballysimon Rd. • Limerick, Ireland

+353 (0) 61 401222 • Fax: +353 (0) 61 401942

Email: info@methode.ie • Web: ireland.methode.com/main.html

Far East:

Methode Electronics Far East, Pte. Ltd.

1 Tuas Lane, Jurong Town • Singapore 638610

65-68615444 • Fax: 65-68614777

Email: sales@methode.com.sg • Web: www.methode.com/mefe/index.html