



Integrated  
Circuit  
Systems, Inc.

# ICS813001I

## DUAL VCXO w/3.3V, 2.5V LVPECL FEMTOCLOCK™ PLL

### GENERAL DESCRIPTION



The ICS813001I is a dual VCXO + FemtoClock™ Multiplier designed for use in Discrete PLL loops. Two selectable external VCXO crystals allow the device to be used in multi-rate applications, where a given line card can be switched, for example, between 1Gb Ethernet (125MHz system reference clock) and 1Gb Fibre Channel (106.25MHz system reference clock) modes. Of course, a multitude of other applications are also possible such as switching between 74.25MHz and 74.175824MHz for HDTV, switching between SONET, FEC and non FEC rates, etc.

The ICS813001I is a two stage device – a VCXO followed by a FemtoClock PLL. The FemtoClock PLL can multiply the crystal frequency of the VCXO to provide an output frequency range of 40.83MHz to 640MHz, with a random rms phase jitter of less than 1ps (12kHz – 20MHz). This phase jitter performance meets the requirements of 1Gb/10Gb Ethernet, 1Gb, 2Gb, 4Gb and 10Gb Fibre Channel, and SONET up to OC48. The FemtoClock PLL can also be bypassed if frequency multiplication is not required. For testing/debug purposes, de-assertion of the output enable pin will place both Q and nQ in a high impedance state.

### BLOCK DIAGRAM

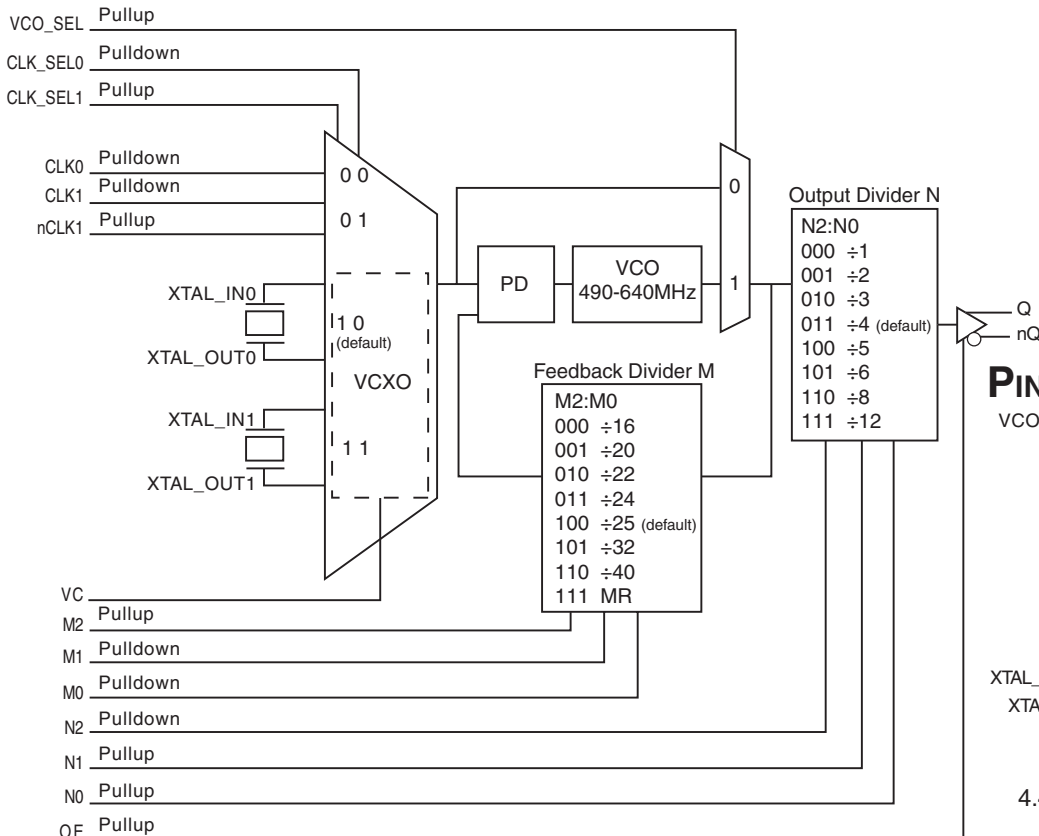

### FEATURES

- One 3.3V or 2.5V LVPECL output pair
- Two selectable crystal oscillator interfaces for the VCXO, one differential clock or one LVCMOS/LVTTL clock inputs
- CLK1/nCLK1 supports the following input types: LVPECL, LVDS, LVHSTL, SSTL, HCSL
- Crystal operating frequency range: 14MHz - 24MHz
- VCO range: 490MHz - 640MHz
- Output frequency range: 40.83MHz - 640MHz
- VCXO pull range: ±100ppm (typical)
- Supports the following applications (among others): SONET, Ethernet, Fibre Channel, HDTV, MPEG
- RMS phase jitter @ 622.08MHz (12kHz - 20MHz): 0.84 (typical)
- Supply voltage modes:
 

$V_{CC}/V_{CCO}$	
3.3V/3.3V	
3.3V/2.5V	
2.5V/2.5V	
- -40°C to 85°C ambient operating temperature
- Available in both, Standard and RoHS/Lead-Free compliant packages

### PIN ASSIGNMENT

VCO_SEL	1	24	CLK_SEL1
N0	2	23	CLK_SEL0
N1	3	22	OE
N2	4	21	M2
VCCO	5	20	M1
Q	6	19	M0
nQ	7	18	CLK1
VEE	8	17	nCLK1
VCCA	9	16	CLK0
VCC	10	15	VC
XTAL_OUT1	11	14	XTAL_IN0
XTAL_IN1	12	13	XTAL_OUT0

### ICS813001I

#### 24-Lead TSSOP

4.40mm x 7.8mm x 0.92mm  
package body  
**G Package**  
Top View



**TABLE 1. PIN DESCRIPTIONS**

Νομ βερ	Νομ ε	Τυπε		Δεσχηπιον
1	VCO_SEL	Input	Pullup	VCO select pin. LVCMOS/LVTTL interface levels.
2, 3	N0, N1	Input	Pullup	Output divider select pins. Default value = ÷4. LVCMOS/LVTTL interface levels.
4	N2	Input	Pulldown	
5	V <sub>CCO</sub>	Power		Output supply pin.
6, 7	Q, nQ	Ouput		Differential output pair. LVPECL interface levels.
8	V <sub>EE</sub>	Power		Negative supply pin.
9	V <sub>CCA</sub>	Power		Analog supply pin.
10	V <sub>CC</sub>	Power		Core supply pin.
11 12	XTAL_OUT1, XTAL_IN1	Input		Parallel resonant crystal interface. XTAL_OUT1 is the output, XTAL_IN1 is the input.
13 14	XTAL_OUT0, XTAL_IN0	Input		Parallel resonant crystal interface. XTAL_OUT0 is the output, XTAL_IN0 is the input.
15	VC	Input		VCXO control voltage input.
16	CLK0	Input	Pulldown	LVCMOS/LVTTL clock input.
17	nCLK1	Input	Pullup	Inverting differential clock input.
18	CLK1	Input	Pulldown	Non-inverting differential clock input.
19, 20	M0, M1	Input	Pulldown	Feedback divider select pins. Default value = ÷25. LVCMOS/LVTTL interface levels.
21	M2	Input	Pullup	
22	OE	Input	Pullup	Output enable. When HIGH, the output is active. When LOW, the output is in a high impedance state. LVCMOS/LVTTL interface levels.
23	CLK_SEL0	Input	Pulldown	Clock select pin. LVCMOS/LVTTL interface levels. Refer to Table 3.
24	CLK_SEL1	Input	Pullup	

NOTE: *Pulldown and Pullup* refer to internal input resistors. See Table 2, Pin Characteristics, for typical values.

**TABLE 2. PIN CHARACTERISTICS**

Symbol	Parameter	Test Conditions	Minimum	Typical	Maximum	Units
C <sub>IN</sub>	Input Capacitance			4		pF
R <sub>PULLDOWN</sub>	Input Pulldown Resistor			51		kΩ
R <sub>PULLUP</sub>	Input Pullup Resistor			51		kΩ

**TABLE 3. CONTROL INPUT FUNCTION TABLE**

Inputs		
CLK_SEL1	CLK_SELO	Selected Input
0	0	CLK0
0	1	CLK1, nCLK1
1	0	XTAL0
1	1	XTAL1



**ABSOLUTE MAXIMUM RATINGS**

Supply Voltage, $V_{CC}$	4.6V
Inputs, $V_I$	-0.5V to $V_{CC} + 0.5V$
Outputs, $I_O$ (LVPECL)	
Continuous Current	50mA
Surge Current	100mA
Package Thermal Impedance, $\theta_{JA}$	70°C/W (0 lfpm)
Storage Temperature, $T_{STG}$	-65°C to 150°C

NOTE: Stresses beyond those listed under Absolute Maximum Ratings may cause permanent damage to the device. These ratings are stress specifications only. Functional operation of product at these conditions or any conditions beyond those listed in the *DC Characteristics* or *AC Characteristics* is not implied. Exposure to absolute maximum rating conditions for extended periods may affect product reliability.

**TABLE 4A. POWER SUPPLY DC CHARACTERISTICS,  $V_{CC} = V_{CCA} = V_{CCO} = 3.3V \pm 5\%$ ,  $T_A = -40^\circ C$  TO  $85^\circ C$**

Symbol	Parameter	Test Conditions	Minimum	Typical	Maximum	Units
$V_{CC}$	Core Supply Voltage		3.135	3.3	3.465	V
$V_{CCA}$	Analog Supply Voltage		3.135	3.3	3.465	V
$V_{CCO}$	Output Supply Voltage		3.135	3.3	3.465	V
$I_{EE}$	Power Supply Current				130	mA
$I_{CCA}$	Analog Supply Current				10	mA

**TABLE 4B. POWER SUPPLY DC CHARACTERISTICS,  $V_{CC} = V_{CCA} = 3.3V \pm 5\%$ ,  $V_{CCO} = 2.5V \pm 5\%$ ,  $T_A = -40^\circ C$  TO  $85^\circ C$**

Symbol	Parameter	Test Conditions	Minimum	Typical	Maximum	Units
$V_{CC}$	Core Supply Voltage		3.135	3.3	3.465	V
$V_{CCA}$	Analog Supply Voltage		3.135	3.3	3.465	V
$V_{CCO}$	Output Supply Voltage		2.375	2.5	2.625	V
$I_{EE}$	Power Supply Current				130	mA
$I_{CCA}$	Analog Supply Current				10	mA

**TABLE 4C. POWER SUPPLY DC CHARACTERISTICS,  $V_{CC} = V_{CCA} = V_{CCO} = 2.5V \pm 5\%$ ,  $T_A = -40^\circ C$  TO  $85^\circ C$**

Symbol	Parameter	Test Conditions	Minimum	Typical	Maximum	Units
$V_{CC}$	Core Supply Voltage		2.375	2.5	2.625	V
$V_{CCA}$	Analog Supply Voltage		2.375	2.5	2.625	V
$V_{CCO}$	Output Supply Voltage		2.375	2.5	2.625	V
$I_{EE}$	Power Supply Current				125	mA
$I_{CCA}$	Analog Supply Current				10	mA



**TABLE 4C. LVCMOS / LVTTTL DC CHARACTERISTICS, TA = -40°C TO 85°C**

Symbol	Parameter	Test Conditions	Minimum	Typical	Maximum	Units
V <sub>IH</sub>	Input High Voltage	V <sub>CC</sub> = 3.3V	2.0		V <sub>CC</sub> + 0.3	V
		V <sub>CC</sub> = 2.5V	1.7		V <sub>CC</sub> + 0.3	V
V <sub>IL</sub>	Input Low Voltage	V <sub>CC</sub> = 3.3V	-0.3		0.8	V
		V <sub>CC</sub> = 2.5V	-0.3		0.7	V
VC	VCXO Control Voltage		0		V <sub>CC</sub>	V
I <sub>IH</sub>	Input High Current	N2, M0, M1, CLK0, CLK_SEL0 V <sub>CC</sub> = V <sub>IN</sub> = 3.465V or 2.625V			150	μA
		N0, N1, M2, VCO_SEL, CLK_SEL1 V <sub>CC</sub> = V <sub>IN</sub> = 3.465V or 2.625V			5	μA
I <sub>IL</sub>	Input Low Current	N2, M0, M1, CLK0, CLK_SEL0 V <sub>CC</sub> = 3.465V or 2.625V, V <sub>IN</sub> = 0V	-5			μA
		N0, N1, M2, VCO_SEL, CLK_SEL1 V <sub>CC</sub> = 3.465V or 2.625V, V <sub>IN</sub> = 0V	-150			μA
I <sub>VC</sub>	Input Current of V <sub>c</sub> pin	V <sub>CC</sub> = 3.465V or 2.625V	-100		100	μA

**TABLE 4D. DIFFERENTIAL DC CHARACTERISTICS, TA = -40°C TO 85°C**

Symbol	Parameter	Test Conditions	Minimum	Typical	Maximum	Units
I <sub>IH</sub>	Input High Current	CLK1 V <sub>IN</sub> = V <sub>CC</sub> = 3.465V or 2.625V			150	μA
		nCLK1 V <sub>IN</sub> = V <sub>CC</sub> = 3.465V or 2.625V			5	μA
I <sub>IL</sub>	Input Low Current	CLK1 V <sub>IN</sub> = 0V, V <sub>CC</sub> = 3.465V or 2.625V	-5			μA
		nCLK1 V <sub>IN</sub> = 0V, V <sub>CC</sub> = 3.465V or 2.625V	-150			μA
V <sub>PP</sub>	Peak-to-Peak Input Voltage		0.15		1.3	V
V <sub>CMR</sub>	Common Mode Input Voltage; NOTE 1, 2		V <sub>EE</sub> + 0.5		V <sub>CC</sub> - 0.85	V

NOTE 1: Common mode voltage is defined as V<sub>IH</sub>.

NOTE 2: For single ended applications, the maximum input voltage for CLK1, nCLK1 is V<sub>CC</sub> + 0.3V.

**TABLE 4E. LVPECL DC CHARACTERISTICS, TA = -40°C TO 85°C**

Symbol	Parameter	Test Conditions	Minimum	Typical	Maximum	Units
V <sub>OH</sub>	Output High Voltage; NOTE 1		V <sub>CCO</sub> - 1.4		V <sub>CCO</sub> - 0.9	V
V <sub>OL</sub>	Output Low Voltage; NOTE 1		V <sub>CCO</sub> - 2.0		V <sub>CCO</sub> - 1.7	V
V <sub>SWING</sub>	Peak-to-Peak Output Voltage Swing		0.6		1.0	V

NOTE 1: Outputs terminated with 50Ω to V<sub>CCO</sub> - 2V.



Integrated  
Circuit  
Systems, Inc.

# ICS813001

DUAL VCXO w/3.3V, 2.5V LVPECL  
FEMTOCLOCK™ PLL

**TABLE 5A. AC CHARACTERISTICS,  $V_{CC} = V_{CCA} = V_{CCO} = 3.3V \pm 5\%$ ,  $T_A = -40^\circ\text{C}$  TO  $85^\circ\text{C}$**

Symbol	Parameter	Test Conditions	Minimum	Typical	Maximum	Units
$f_{OUT}$	Output Frequency	VCO_SEL = 1	40.83		640	MHz
$f_{jit}(\emptyset)$	RMS Phase Jitter, (Random); NOTE 1	622.08MHz (12kHz - 20MHz)		0.84		ps
$f_{VCO}$	PLL VCO Lock Range		490		640	MHz
$t_R / t_F$	Output Rise/Fall Time	20% to 80%	250		500	ps
odc	Output Duty Cycle	$N \div 1$	43		57	%
		$N \neq \div 1$	48		52	%

NOTE 1: Phase jitter using a crystal interface.

**TABLE 5B. AC CHARACTERISTICS,  $V_{CC} = V_{CCA} = 3.3V \pm 5\%$ ,  $V_{CCO} = 2.5V \pm 5\%$ ,  $T_A = -40^\circ\text{C}$  TO  $85^\circ\text{C}$**

Symbol	Parameter	Test Conditions	Minimum	Typical	Maximum	Units
$f_{OUT}$	Output Frequency	VCO_SEL = 1	40.83		640	MHz
$f_{jit}(\emptyset)$	RMS Phase Jitter, (Random); NOTE 1	622.08MHz (12kHz - 20MHz)		0.87		ps
$f_{VCO}$	PLL VCO Lock Range		490		640	MHz
$t_R / t_F$	Output Rise/Fall Time	20% to 80%	250		500	ps
odc	Output Duty Cycle	$N \div 1$	43		57	%
		$N \neq \div 1$	48		52	%

NOTE 1: Phase jitter using a crystal interface.

**TABLE 5C. AC CHARACTERISTICS,  $V_{CC} = V_{CCA} = V_{CCO} = 2.5V \pm 5\%$ ,  $T_A = -40^\circ\text{C}$  TO  $85^\circ\text{C}$**

Symbol	Parameter	Test Conditions	Minimum	Typical	Maximum	Units
$f_{OUT}$	Output Frequency	VCO_SEL = 1	40.83		640	MHz
$f_{jit}(\emptyset)$	RMS Phase Jitter, (Random); NOTE 1	622.08MHz (12kHz - 20MHz)		1.2		ps
$f_{VCO}$	PLL VCO Lock Range		490		640	MHz
$t_R / t_F$	Output Rise/Fall Time	20% to 80%	250		500	ps
odc	Output Duty Cycle	$N \div 1$	43		57	%
		$N \neq \div 1$	48		52	%

NOTE 1: Phase jitter using a crystal interface.



**TYPICAL PHASE NOISE AT 622.08MHz @ 3.3V**

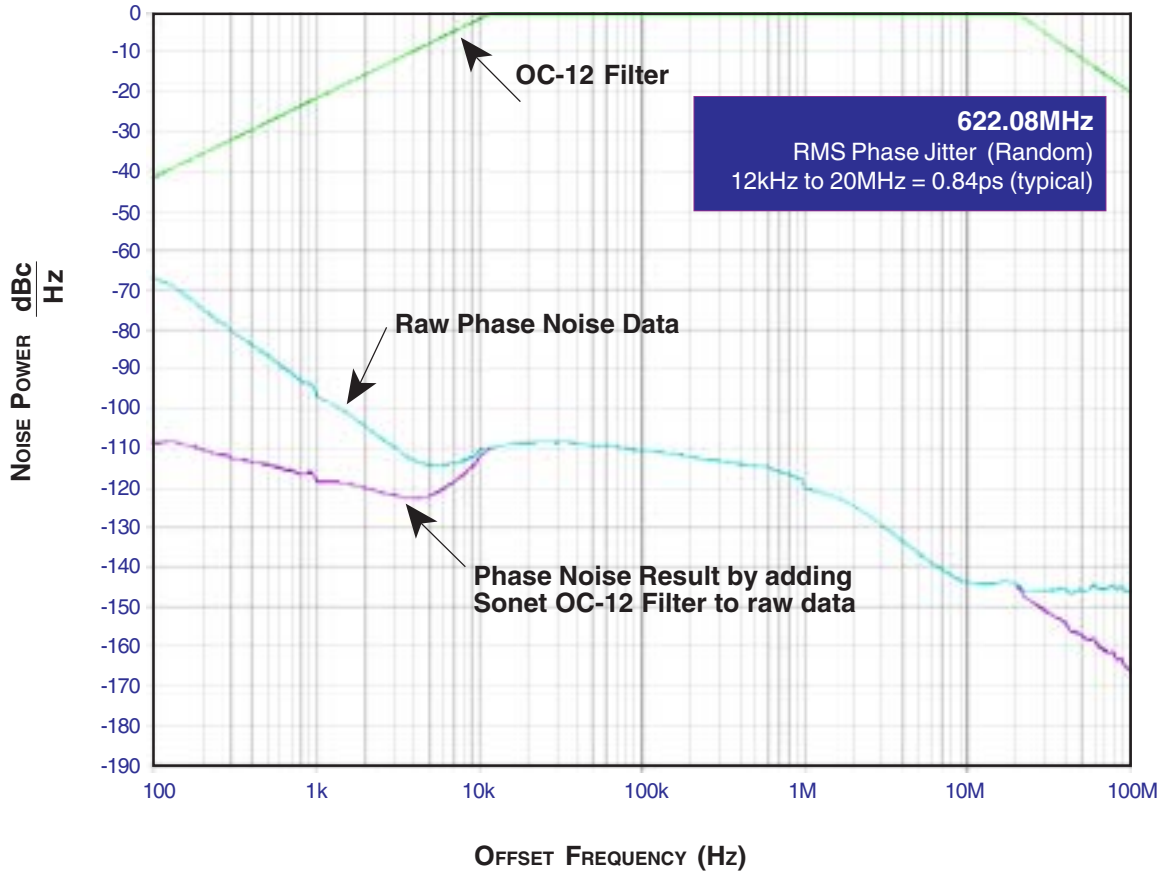



## PARAMETER MEASUREMENT INFORMATION

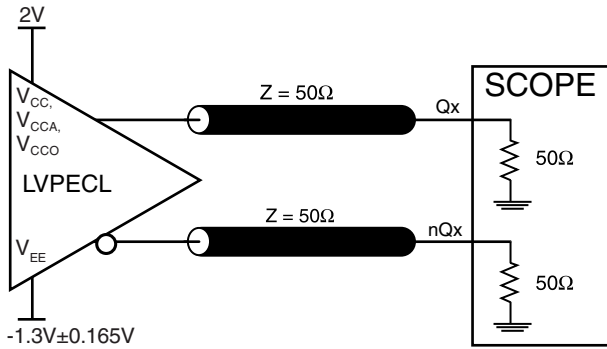

**3.3V CORE/3.3V LVPECL OUTPUT LOAD AC TEST CIRCUIT**

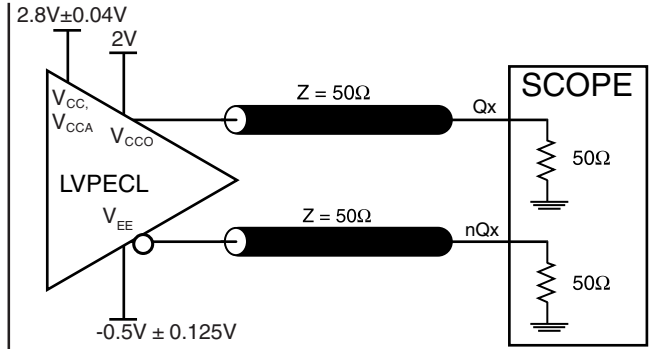

**3.3V CORE/2.5V LVPECL OUTPUT LOAD AC TEST CIRCUIT**

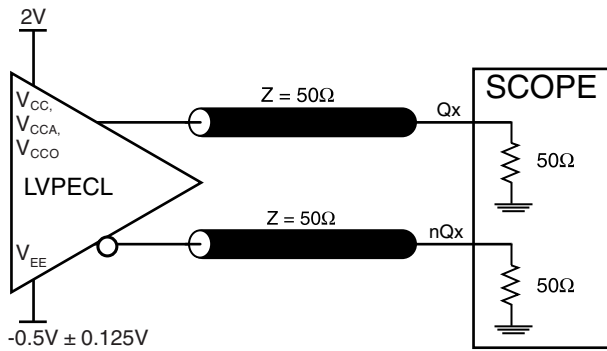

**2.5V CORE/2.5V LVPECL OUTPUT LOAD AC TEST CIRCUIT**

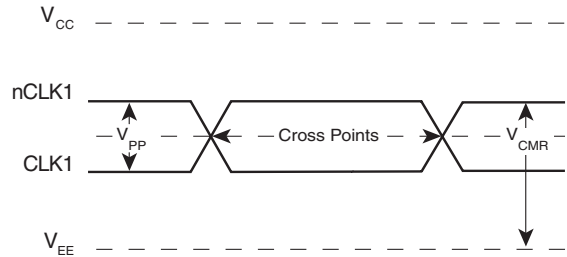

**DIFFERENTIAL INPUT LEVELS**

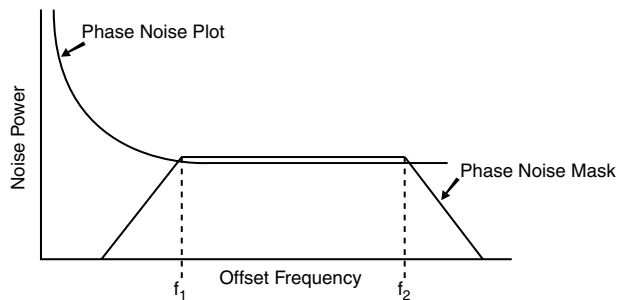

$$\text{RMS Jitter} = \sqrt{\text{Area Under the Masked Phase Noise Plot}}$$

**RMS PHASE JITTER**

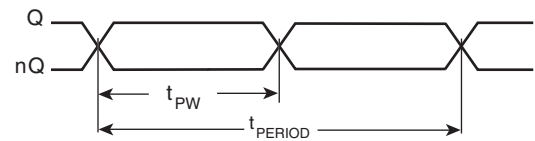

$$\text{odc} = \frac{t_{PW}}{t_{PERIOD}} \times 100\%$$

**OUTPUT DUTY CYCLE/PULSE WIDTH/PERIOD**

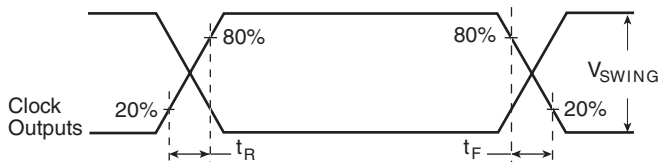

**OUTPUT RISE/FALL TIME**



## APPLICATION INFORMATION

### POWER SUPPLY FILTERING TECHNIQUES

As in any high speed analog circuitry, the power supply pins are vulnerable to random noise. The ICS813001I provides separate power supplies to isolate any high switching noise from the outputs to the internal PLL.  $V_{CC}$ ,  $V_{CCA}$ , and  $V_{CCO}$  should be individually connected to the power supply plane through vias, and bypass capacitors should be used for each pin. To achieve optimum jitter performance, power supply isolation is required. *Figure 1* illustrates how a  $10\Omega$  resistor along with a  $10\mu\text{F}$  and a  $.01\mu\text{F}$  bypass capacitor should be connected to each  $V_{CCA}$ .

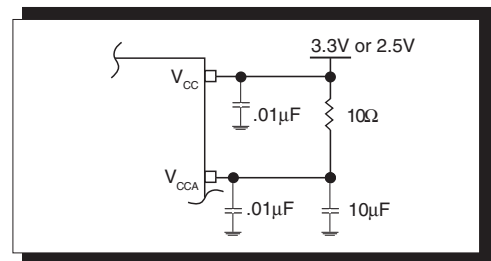

FIGURE 1. POWER SUPPLY FILTERING

### WIRING THE DIFFERENTIAL INPUT TO ACCEPT SINGLE ENDED LEVELS

*Figure 2* shows how the differential input can be wired to accept single ended levels. The reference voltage  $V_{REF} = V_{CC}/2$  is generated by the bias resistors  $R1$ ,  $R2$  and  $C1$ . This bias circuit should be located as close as possible to the input pin. The ratio

of  $R1$  and  $R2$  might need to be adjusted to position the  $V_{REF}$  in the center of the input voltage swing. For example, if the input clock swing is only 2.5V and  $V_{CC} = 3.3\text{V}$ ,  $V_{REF}$  should be 1.25V and  $R2/R1 = 0.609$ .

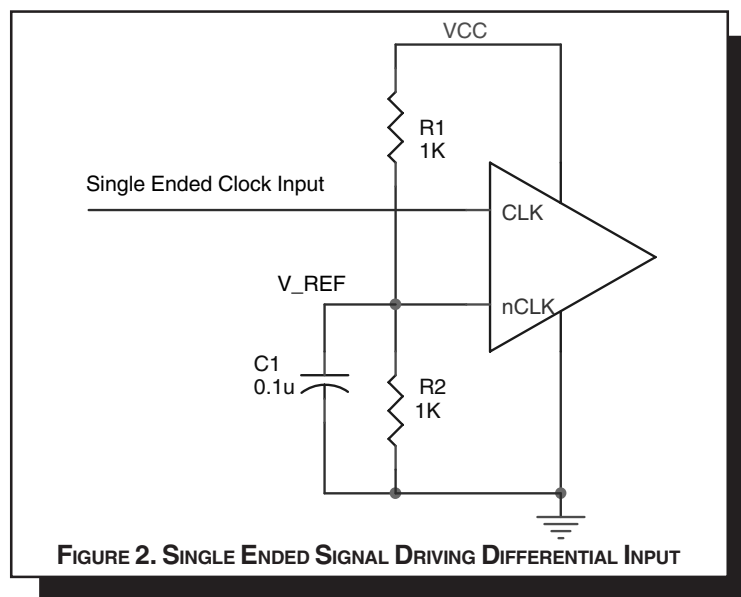

FIGURE 2. SINGLE ENDED SIGNAL DRIVING DIFFERENTIAL INPUT





### VCXO CRYSTAL SELECTION

Choosing a crystal with the correct characteristics is one of the most critical steps in using a Voltage Controlled Crystal Oscillator (VCXO). The crystal parameters affect the tuning

range and accuracy of a VCXO. Below are the key variables and an example of using the crystal parameters to calculate the tuning range of the VCXO.

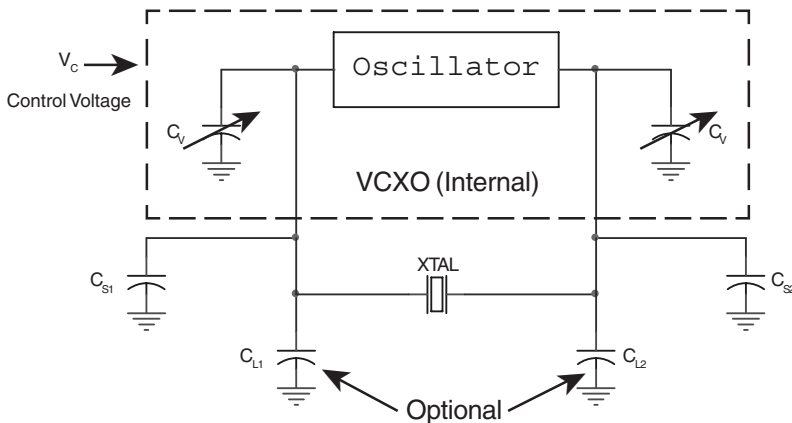

- $V_c$  - Control voltage used to tune frequency
- $C_v$  - Varactor capacitance, varies due to the change in control voltage
- $C_{L1}, C_{L2}$  - Load tuning capacitance used for fine tuning or centering nominal frequency
- $C_{s1}, C_{s2}$  - Stray Capacitance caused by pads, vias, and other board parasitics

**FIGURE 3. VCXO OSCILLATOR CIRCUIT**

**TABLE 6. EXAMPLE CRYSTAL PARAMETERS**

Symbol	Parameter	Test Conditions	Minimum	Typical	Maximum	Units
$f_N$	Nominal Frequency		14		24	MHz
$f_T$	Frequency Tolerance				$\pm 20$	ppm
$f_s$	Frequency Stability				$\pm 20$	ppm
	Operating Temperature Range		0		70	$^{\circ}\text{C}$
$C_L$	Load Capacitance			12		pF
$C_O$	Shunt Capacitance			4		pF
$C_1, C_2$	Pullability Ratio			220	240	
ESR	Equivalent Series Resistance				20	
	Drive Level				1	mW
	Aging @ 25 $^{\circ}\text{C}$			$\pm 3$ per year		ppm
	Mode of Operation			Fundamental		



**TABLE 7. VARACTOR PARAMETERS**

Symbol	Parameter	Test Conditions	Minimum	Typical	Maximum	Units
$C_{V\_LOW}$	Low Varactor Capacitance	$V_C = 0V$		15		pF
$C_{V\_HIGH}$	High Varactor Capacitance	$V_C = 3.3V$		27.4		pF

**FORMULAS**

$$C_{Low} = \frac{(C_{L1} + C_{S1} + C_{V\_Low}) \cdot (C_{L2} + C_{S2} + C_{V\_Low})}{(C_{L1} + C_{S1} + C_{V\_Low}) + (C_{L2} + C_{S2} + C_{V\_Low})}$$

$$C_{High} = \frac{(C_{L1} + C_{S1} + C_{V\_High}) \cdot (C_{L2} + C_{S2} + C_{V\_High})}{(C_{L1} + C_{S1} + C_{V\_High}) + (C_{L2} + C_{S2} + C_{V\_High})}$$

- $C_{Low}$  is the effective capacitance due to the low varactor capacitance, load capacitance and stray capacitance.  $C_{Low}$  determines the high frequency component on the TPR.
- $C_{High}$  is the effective capacitance due to the high varactor capacitance, load capacitance and stray capacitance.  $C_{High}$  determines the low frequency component on the TPR.

$$Total\ Pull\ Range\ (TPR) = \left( \frac{1}{2 \cdot C_0 / C_1 \cdot \left(1 + C_{Low} / C_0\right)} - \frac{1}{2 \cdot C_0 / C_1 \cdot \left(1 + C_{High} / C_0\right)} \right) \cdot 10^6$$

Absolute Pull Range (APR) = Total Pull Range – (Frequency Tolerance + Frequency Stability + Aging)

**EXAMPLE CALCULATIONS**

Using the tables and figures above, we can now calculate the TPR and APR of the VCXO using the example crystal parameters. For the numerical example below there were some assumptions made. First, the stray capacitance ( $C_{S1}$ ,  $C_{S2}$ ), which is all the excess capacitance due to board parasitic, is 4pF. Second, the expected lifetime of the project

is 5 years; hence the inaccuracy due to aging is ±15ppm. Third, though many boards will not require load tuning capacitors ( $C_{L1}$ ,  $C_{L2}$ ), it is recommended for long-term consistent performance of the system that two tuning capacitor pads be placed into every design. Typical values for the load tuning capacitors will range from 0 to 4pF.

$$C_{Low} = \frac{(0 + 4pf + 15pf) \cdot (0 + 4pf + 15pf)}{(0 + 4pf + 15pf) \cdot (0 + 4pf + 15pf)} = 9.5pf$$

$$C_{High} = \frac{(0 + 4pf + 27.4pf) \cdot (0 + 4pf + 27.4pf)}{(0 + 4pf + 27.4pf) \cdot (0 + 4pf + 27.4pf)} = 15.7pf$$

$$TPR = \left( \frac{1}{2 \cdot 220 \cdot \left(1 + 9.5pf / 4pf\right)} - \frac{1}{2 \cdot 220 \cdot \left(1 + 15.7pf / 4pf\right)} \right) \cdot 10^6 = 212ppm$$

TPR = ±106ppm

APR = 106ppm – (20ppm + 20ppm + 15ppm) = ±51ppm

The example above will ensure a total pull range of ±106 ppm with an APR of ±51ppm. Many times, board designers may select their own crystal based on their application. If the application requires a tighter APR, a crystal

with better pullability ( $C_0/C_1$  ratio) can be used. Also, with the equations above, one can vary the frequency tolerance, temperature stability, and aging or shunt capacitance to achieve the required pullability.



### DIFFERENTIAL CLOCK INPUT INTERFACE

The CLK/nCLK accepts LVDS, LVPECL, LVHSTL, SSTL, HCSL and other differential signals. Both  $V_{SWING}$  and  $V_{OH}$  must meet the  $V_{PP}$  and  $V_{CMR}$  input requirements. Figures 4A to 4E show interface examples for the HiPerClockS CLK/nCLK input driven by the most common driver types. The input interfaces suggested

here are examples only. Please consult with the vendor of the driver component to confirm the driver termination requirements. For example in *Figure 4A*, the input termination applies for ICS HiPerClockS LVHSTL drivers. If you are using an LVHSTL driver from another vendor, use their termination recommendation.

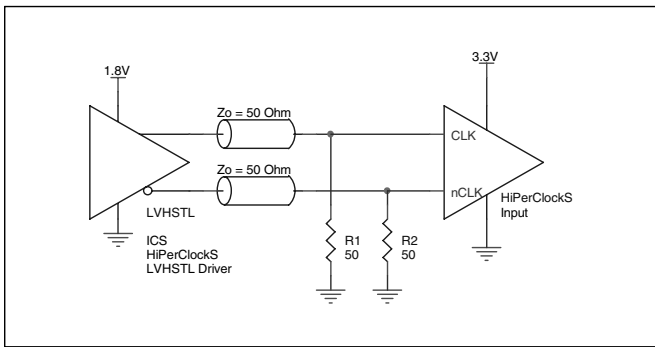

**FIGURE 4A. HiPerClockS CLK/nCLK INPUT DRIVEN BY ICS HiPerClockS LVHSTL DRIVER**

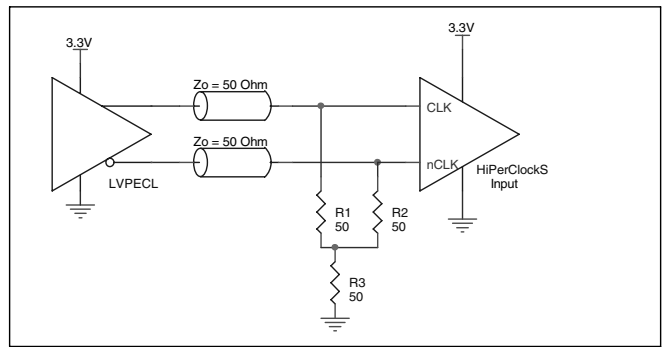

**FIGURE 4B. HiPerClockS CLK/nCLK INPUT DRIVEN BY 3.3V LVPECL DRIVER**

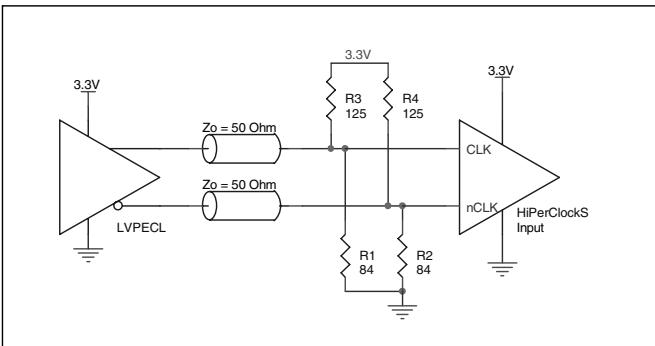

**FIGURE 4C. HiPerClockS CLK/nCLK INPUT DRIVEN BY 3.3V LVPECL DRIVER**

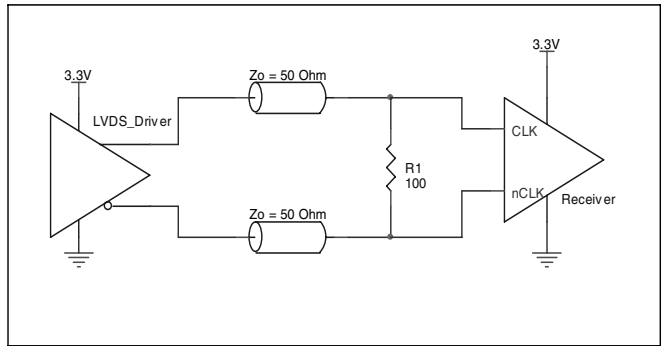

**FIGURE 4D. HiPerClockS CLK/nCLK INPUT DRIVEN BY 3.3V LVDS DRIVER**

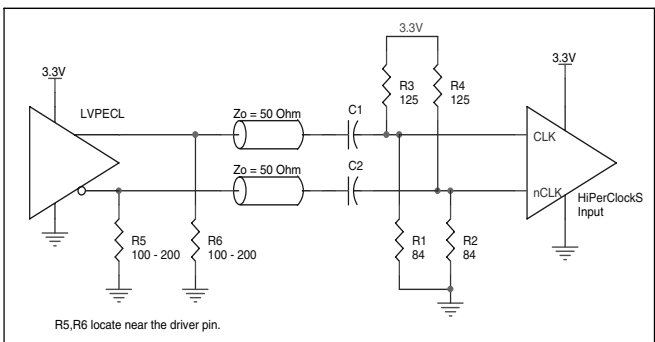

**FIGURE 4E. HiPerClockS CLK/nCLK INPUT DRIVEN BY 3.3V LVPECL DRIVER WITH AC COUPLE**



## RECOMMENDATIONS FOR UNUSED INPUT AND OUTPUT PINS

### INPUTS:

#### CRYSTAL INPUT:

For applications not requiring the use of the crystal oscillator input, both XTAL\_IN and XTAL\_OUT can be left floating. Though not required, but for additional protection, a 1kΩ resistor can be tied from XTAL\_IN to ground.

#### CLK INPUT:

For applications not requiring the use of a clock input, it can be left floating. Though not required, but for additional protection, a 1kΩ resistor can be tied from the CLK input to ground.

#### CLK/nCLK INPUT:

For applications not requiring the use of the differential input, both CLK and nCLK can be left floating. Though not required, but for additional protection, a 1kΩ resistor can be tied from CLK to ground.

#### LVC MOS CONTROL PINS:

All control pins have internal pull-ups or pull-downs; additional resistance is not required but can be added for additional protection. A 1kΩ resistor can be used.

VC input pin - do not float, must be biased.

### OUTPUTS:

#### LVPECL OUTPUT

All unused LVPECL outputs can be left floating. We recommend that there is no trace attached. Both sides of the differential output pair should either be left floating or terminated.

## TERMINATION FOR 3.3V LVPECL OUTPUT

The clock layout topology shown below is a typical termination for LVPECL outputs. The two different layouts mentioned are recommended only as guidelines.

FOUT and nFOUT are low impedance follower outputs that generate ECL/LVPECL compatible outputs. Therefore, terminating resistors (DC current path to ground) or current sources must be used for functionality. These outputs are designed to drive 50Ω transmission lines.

Matched impedance techniques should be used to maximize operating frequency and minimize signal distortion. *Figures 5A and 5B* show two different layouts which are recommended only as guidelines. Other suitable clock layouts may exist and it would be recommended that the board designers simulate to guarantee compatibility across all printed circuit and clock component process variations.

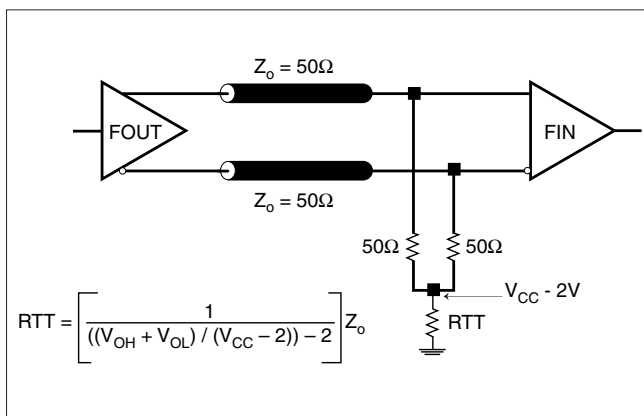

FIGURE 5A. LVPECL OUTPUT TERMINATION

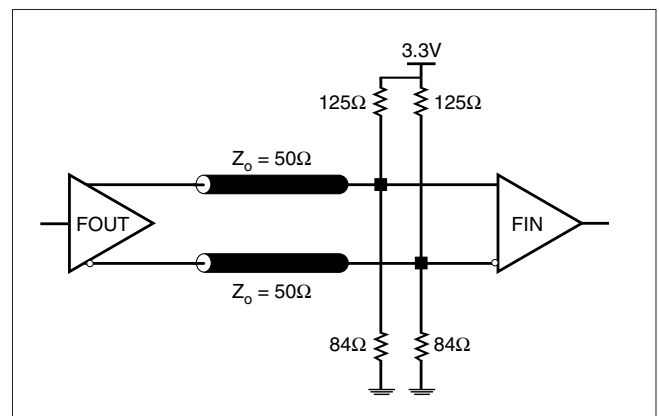

FIGURE 5B. LVPECL OUTPUT TERMINATION



**TERMINATION FOR 2.5V LVPECL OUTPUT**

Figure 6A and Figure 6B show examples of termination for 2.5V LVPECL driver. These terminations are equivalent to terminating 50Ω to  $V_{CC} - 2V$ . For  $V_{CC} = 2.5V$ , the  $V_{CC} - 2V$  is very

close to ground level. The R3 in Figure 6B can be eliminated and the termination is shown in Figure 6C.

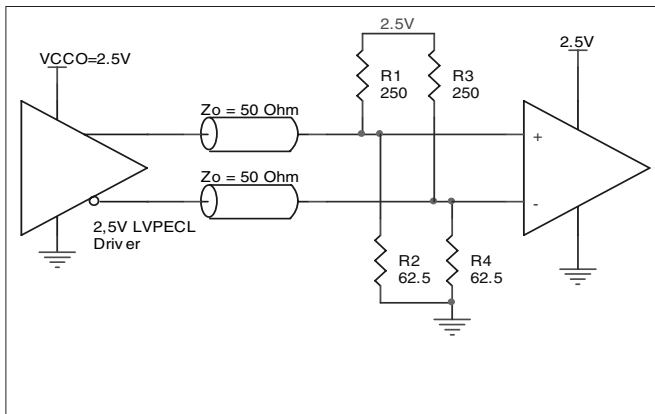

**FIGURE 6A. 2.5V LVPECL DRIVER TERMINATION EXAMPLE**

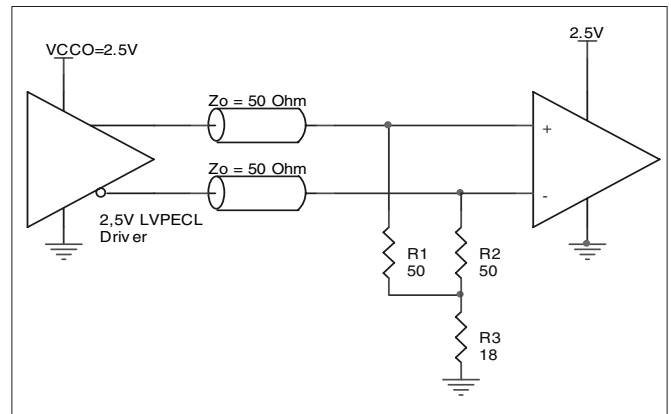

**FIGURE 6B. 2.5V LVPECL DRIVER TERMINATION EXAMPLE**

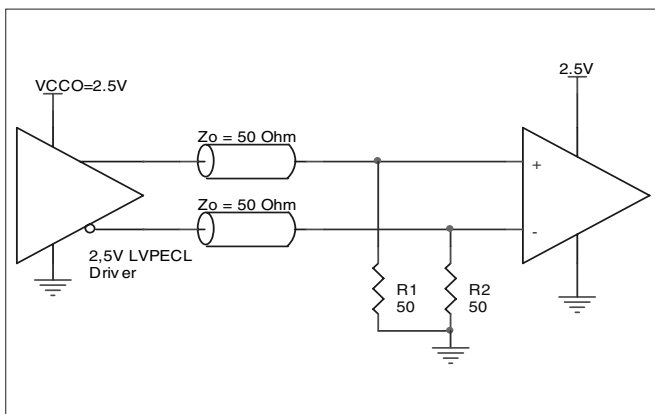

**FIGURE 6C. 2.5V LVPECL TERMINATION EXAMPLE**



## POWER CONSIDERATIONS

This section provides information on power dissipation and junction temperature for the ICS813001I. Equations and example calculations are also provided.

### 1. Power Dissipation.

The total power dissipation for the ICS813001I is the sum of the core power plus the power dissipated in the load(s). The following is the power dissipation for  $V_{CC} = 3.3V + 5\% = 3.465V$ , which gives worst case results.

**NOTE:** Please refer to Section 3 for details on calculating power dissipated in the load.

- Power (core)<sub>MAX</sub> =  $V_{CC\_MAX} * I_{EE\_MAX} = 3.465V * 130mA = 450.45mW$
- Power (outputs)<sub>MAX</sub> = **30mW/Loaded Output pair**

**Total Power**<sub>MAX</sub> (3.465V, with output switching) = 450.45mW + 30mW = **480.5mW**

### 2. Junction Temperature.

Junction temperature,  $T_j$ , is the temperature at the junction of the bond wire and bond pad and directly affects the reliability of the device. The maximum recommended junction temperature for HiPerClockS™ devices is 125°C.

The equation for  $T_j$  is as follows:  $T_j = \theta_{JA} * Pd\_total + T_A$

$T_j$  = Junction Temperature

$\theta_{JA}$  = Junction-to-Ambient Thermal Resistance

$Pd\_total$  = Total Device Power Dissipation (example calculation is in section 1 above)

$T_A$  = Ambient Temperature

In order to calculate junction temperature, the appropriate junction-to-ambient thermal resistance  $\theta_{JA}$  must be used. Assuming a moderate air flow of 1 meter per second and a multi-layer board, the appropriate value is 70°C/W per Table 8 below.

Therefore,  $T_j$  for an ambient temperature of 85°C with all outputs switching is:

$$85^\circ C + 0.481W * 65^\circ C/W = 116.3^\circ C. \text{ This is below the limit of } 125^\circ C.$$

This calculation is only an example.  $T_j$  will obviously vary depending on the number of loaded outputs, supply voltage, air flow, and the type of board (single layer or multi-layer).

**TABLE 8. THERMAL RESISTANCE  $\theta_{JA}$  FOR 24-PIN TSSOP, FORCED CONVECTION**

$\theta_{JA}$ by Velocity (Meters per Second)			
	0	1	2.5
Multi-Layer PCB, JEDEC Standard Test Boards	70°C/W	65°C/W	62°C/W



### 3. Calculations and Equations.

The purpose of this section is to derive the power dissipated into the load.

LVPECL output driver circuit and termination are shown in *Figure 7*.

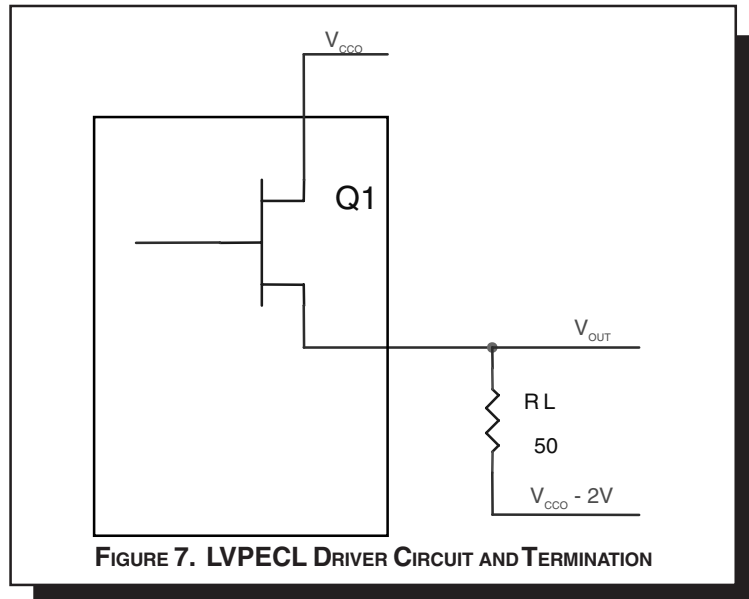

**FIGURE 7. LVPECL DRIVER CIRCUIT AND TERMINATION**

To calculate worst case power dissipation into the load, use the following equations which assume a 50Ω load, and a termination voltage of  $V_{CCO} - 2V$ .

- For logic high,  $V_{OUT} = V_{OH\_MAX} = V_{CCO\_MAX} - 0.9V$

$$(V_{CCO\_MAX} - V_{OH\_MAX}) = 0.9V$$

- For logic low,  $V_{OUT} = V_{OL\_MAX} = V_{CCO\_MAX} - 1.7V$

$$(V_{CCO\_MAX} - V_{OL\_MAX}) = 1.7V$$

Pd\_H is power dissipation when the output drives high.

Pd\_L is the power dissipation when the output drives low.

$$Pd_H = [(V_{OH\_MAX} - (V_{CCO\_MAX} - 2V))/R_L] * (V_{CCO\_MAX} - V_{OH\_MAX}) = [(2V - (V_{CCO\_MAX} - V_{OH\_MAX}))/R_L] * (V_{CCO\_MAX} - V_{OH\_MAX}) = [(2V - 0.9V)/50\Omega] * 0.9V = \mathbf{19.8mW}$$

$$Pd_L = [(V_{OL\_MAX} - (V_{CCO\_MAX} - 2V))/R_L] * (V_{CCO\_MAX} - V_{OL\_MAX}) = [(2V - (V_{CCO\_MAX} - V_{OL\_MAX}))/R_L] * (V_{CCO\_MAX} - V_{OL\_MAX}) = [(2V - 1.7V)/50\Omega] * 1.7V = \mathbf{10.2mW}$$

Total Power Dissipation per output pair = Pd\_H + Pd\_L = **30mW**



Integrated  
Circuit  
Systems, Inc.

**ICS813001I**  
DUAL VCXO w/3.3V, 2.5V LVPECL  
FEMTOCLOCK™ PLL

## RELIABILITY INFORMATION

TABLE 9.  $\theta_{JA}$  vs. AIR FLOW TABLE FOR 24 LEAD TSSOP

$\theta_{JA}$ by Velocity (Meters per Second)			
	0	1	2.5
Multi-Layer PCB, JEDEC Standard Test Boards	70°C/W	65°C/W	62°C/W

### TRANSISTOR COUNT

The transistor count for ICS813001I is: 3948





Integrated  
Circuit  
Systems, Inc.

**ICS813001**  
DUAL VCXO w/3.3V, 2.5V LVPECL  
FEMTOCLOCK™ PLL

PACKAGE OUTLINE - G SUFFIX FOR 24 LEAD TSSOP

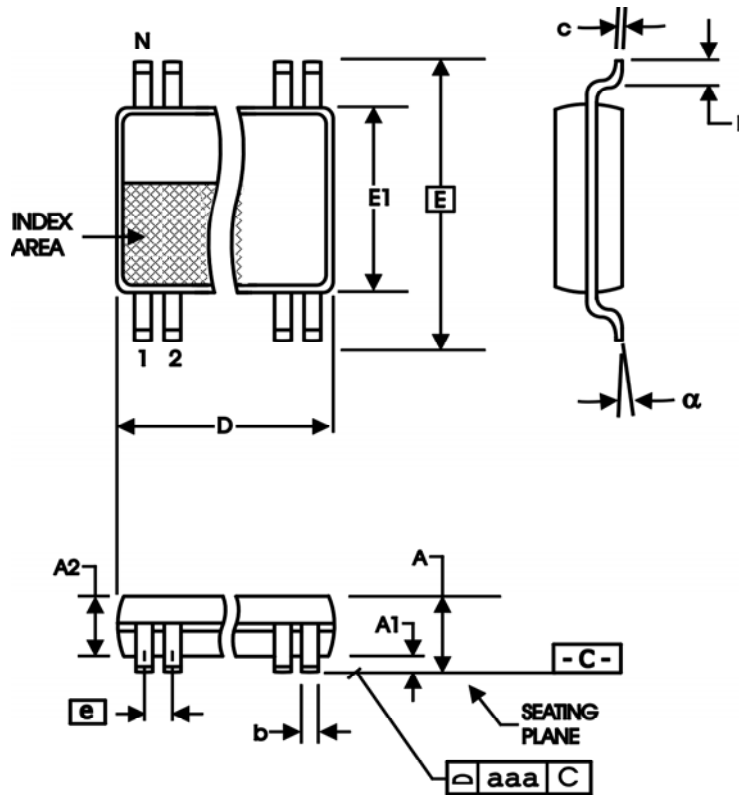

TABLE 10. PACKAGE DIMENSIONS

SYMBOL	Millimeters	
	Minimum	Maximum
N	24	
A	--	1.20
A1	0.05	0.15
A2	0.80	1.05
b	0.19	0.30
c	0.09	0.20
D	7.70	7.90
E	6.40 BASIC	
E1	4.30	4.50
e	0.65 BASIC	
L	0.45	0.75
α	0°	8°
aaa	--	0.10

Reference Document: JEDEC Publication 95, MO-153



Integrated  
Circuit  
Systems, Inc.

**ICS813001I**  
DUAL VCXO w/3.3V, 2.5V LVPECL  
FEMTOCLOCK™ PLL

**TABLE 11. ORDERING INFORMATION**

Part/Order Number	Marking	Package	Shipping Packaging	Temperature
ICS813001AGI	ICS813001AGI	24 Lead TSSOP	tube	-40°C to 85°C
ICS813001AGIT	ICS813001AGI	24 Lead TSSOP	2500 tape & reel	-40°C to 85°C
ICS813001AGILF	ICS813001AGIL	24 Lead "Lead-Free" TSSOP	tube	-40°C to 85°C
ICS813001AGILFT	ICS813001AGIL	24 Lead "Lead-Free" TSSOP	2500 tape & reel	-40°C to 85°C

NOTE: Parts that are ordered with an LF suffix to the part number are the Pb-Free configuration and are RoHS compliant.

The aforementioned trademarks, HiPerClockS and FemtoClocks are trademarks of Integrated Circuit Systems, Inc. or its subsidiaries in the United States and/or other countries. While the information presented herein has been checked for both accuracy and reliability, Integrated Circuit Systems, Incorporated (ICS) assumes no responsibility for either its use or for infringement of any patents or other rights of third parties, which would result from its use. No other circuits, patents, or licenses are implied. This product is intended for use in normal commercial and industrial applications. Any other applications such as those requiring high reliability or other extraordinary environmental requirements are not recommended without additional processing by ICS. ICS reserves the right to change any circuitry or specifications without notice. ICS does not authorize or warrant any ICS product for use in life support devices or critical medical instruments.