

**Product Features:**

- Low Current Consumption
- Ultra Miniature Package
- RoHS Compliant
- Compatible with Leadfree Processing

**Applications:**

- Server & Storage
- CDMA/WCDMA
- 802.11 / Wifi
- T1/E1, T3/E3

<b>Frequency</b>	(Contact Sales Channel for other available frequencies)
<b>Output Level</b> Clipped Sinewave	0.8 V p-p Min.
<b>Output Load</b> Clipped Sinewave	10K Ohms / 10 pF
<b>Frequency Stability</b> Vs Temperature Vs Voltage Vs Load(5%)	See Frequency Stability Table ± 0.2 ppm Max. ± 0.2 ppm Max.
<b>Frequency Tolerance @ 25° C</b>	±2 .0 ppm (After 2 <sup>nd</sup> Reflow)
<b>Aging</b>	± 1 ppm / Year Max.
<b>Supply Voltage</b>	See Supply Voltage Table , tolerance ± 5%
<b>Current</b>	2.0 mA Max.
<b>Voltage Control (I783)</b>	1.5 VDC ± 1.0 VDC, ± 5.0 ppm Min. (Custom Available)
<b>Operating</b>	See Operating Temperature Table
<b>Storage</b>	-40° C to +85° C
<b>Harmonics</b>	-8.0 dBc Max.
<b>Phase Noise</b>	-130 dBc/Hz @ 1KHz

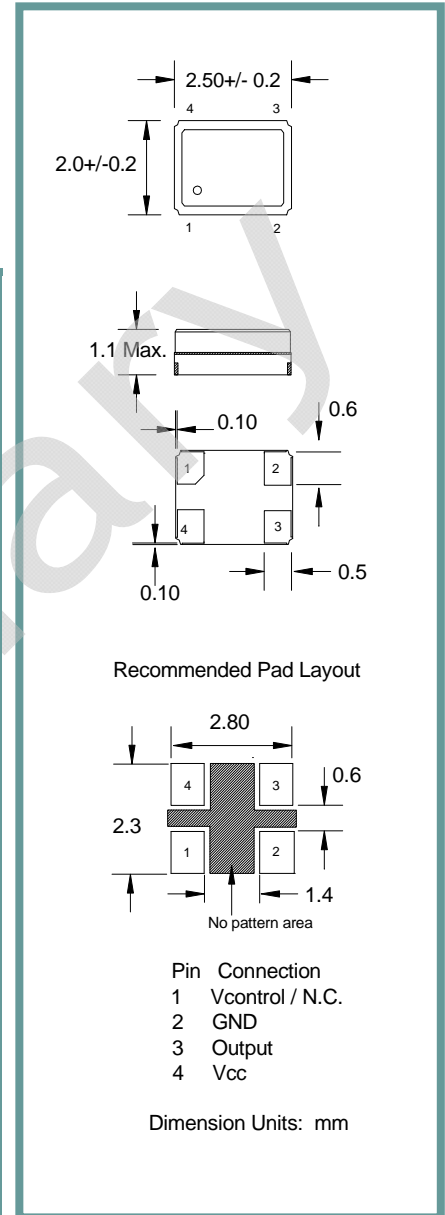

Package	Part Number Guide		Sample Part Number: I583-5P8-26.000 Mhz	
	Operating Temperature	Frequency Stability vs Temperature	Supply Voltage	Frequency
I583 (Clipped Sinewave TCXO) I783 (Clipped Sinewave TCVCXO)	7 = 0° C to +50° C	P = ±2.0 ppm	3 = 3.3 V	- 26.000 MHz
	1 = 0° C to +70° C	Q = ±2.5 ppm	7 = 3.0 V	
	3 = -20° C to +70° C	R = ±3.0 ppm	8 = 2.8 V	
	5 = -30° C to +85° C	J = ±5.0 ppm	2 = 2.7 V	
			1 = 1.8 V	

NOTE: A 0.01 µF bypass capacitor is recommended between Vcc (pin 4) and GND (pin 2) to minimize power supply noise.  
 \*\* Not available for all temperature ranges.



2.0 mm x 2.5 mm Ceramic Package SMD TCXO



I583/I783 Series

**Pb Free Solder Reflow Profile:**

**Typical Application:**

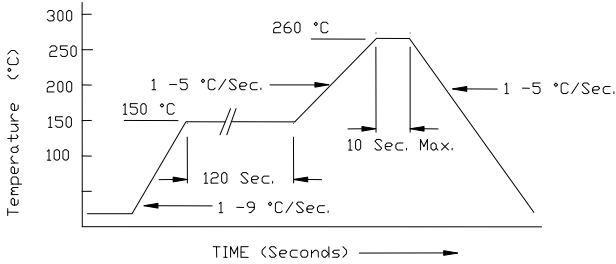

\*Units are backward compatible with 240C reflow processes

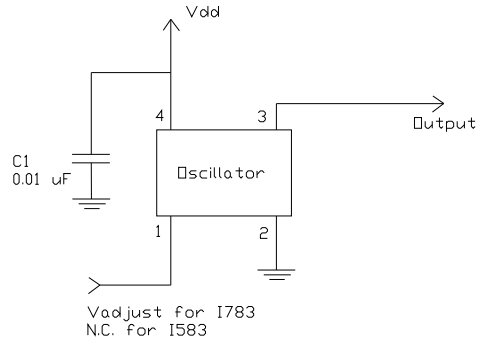

**Package Information:**

MSL = N.A. (package does not contain plastic, storage life is unlimited under normal room conditions).  
Termination = e4 (Au over Ni over W base metalization).

**Tape and Reel Information:**

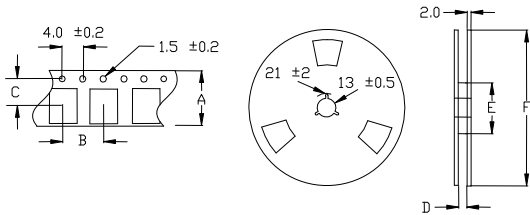

Quantity per Reel	3000
A	8 +/- .3
B	4 +/- .2
C	3.5 +/- .2
D	9 +/- .1 or 12 +/- .3
E	60 / 80
F	180

**Environmental Specifications**

Thermal Shock	MIL-STD-883, Method 1011, Condition A
Moisture Resistance	MIL-STD-883, Method 1004
Mechanical Shock	MIL-STD-883, Method 2002, Condition B
Mechanical Vibration	MIL-STD-883, Method 2007, Condition A
Resistance to Soldering Heat	J-STD-020C, Table 5-2 Pb-free devices (except 2 cycles max)
Hazardous Substance	Pb-Free / RoHS / Green Compliant
Solderability	JESD22-B102-D Method 2 (Preconditioning E)
Terminal Strength	MIL-STD-883, Method 2004, Test Condition D
Gross Leak	MIL-STD-883, Method 1014, Condition C
Fine Leak	MIL-STD-883, Method 1014, Condition A2, R1=2x10 <sup>-8</sup> atm cc/s
Solvent Resistance	MIL-STD-202, Method 215

**Marking**

Line 1: XXXX(Freq.Code,Production Code,Year, Month,Date) (Example="GB17L")  
Line 2: XXXXX (Crystal Code)