

**Metallized Polyester Film Capacitor
Quality Assessment: CECC 30 401-059
Special Version - Crimped to pcm 10**

MAIN APPLICATIONS:

Blocking, bypassing, filtering and timing, high frequency coupling and decoupling of fast digital circuits. Interference suppression in low voltage applications. High pulse load. High temperature operations.

MARKING:

Manufacturer's logo/type/C-value/rated voltage/tolerance/date of manufacture

DIELECTRIC:

Polyester film

ELECTRODES:

Vacuum deposited aluminum

COATING:

Flame retardant plastic case (UL-class 94 V-0), green, epoxy resin sealed

CONSTRUCTION:

Stacked metallized polyester film

LEADS:

Tinned wire

IEC TEST CLASSIFICATION:

55/125/56, according to IEC 60068

55/100/21 (for 4.7µF/40 VDC)

OPERATING TEMPERATURE RANGE:

- 55°C to + 125°C

- 55°C to + 100°C (for 4.7µF/40 VDC)

CAPACITANCE RANGE:

1000pF to 4.7µF

CAPACITANCE TOLERANCES:

± 20% (M), ± 10% (K), ± 5% (J)

RATED VOLTAGES (U_R):

40 VDC, 50 VDC, 63 VDC, 100 VDC, 250 VDC

PERMISSIBLE AC VOLTAGES (RMS) UP TO 60Hz:

25 VAC, 30 VAC, 40 VAC, 63 VAC, 160 VAC

TEST VOLTAGE (ELECTRODE/ELECTRODE):

1.6 x U_R for 2 sec.

INSULATION RESISTANCE:

Measured at 100 VDC (50 VDC and 63 VDC series

measured at 50 VDC) after one minute

For C ≤ 0.33µF and U_R > 100 VDC:

30,000 MΩ minimum value (100,000 MΩ typical value)

For C ≤ 0.33µF and U_R ≤ 100 VDC:

15,000 MΩ minimum value (100,000 MΩ typical value)

Dimensions in millimeters

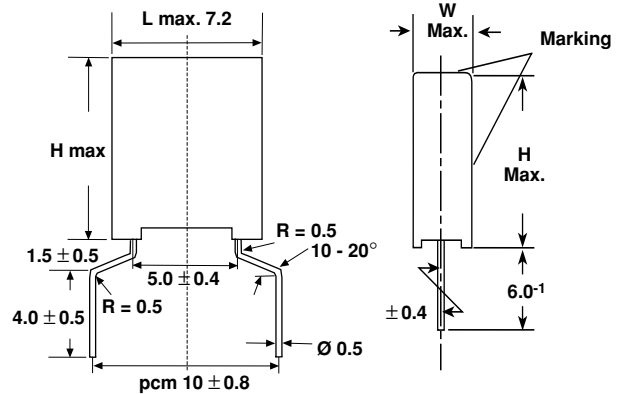

TIME CONSTANT:

Measured at 100 VDC (50 VDC and 63 VDC series measured at 50 VDC, 40 VDC measured with U_R) after one minute

For 0.33µF < C ≤ 3.3µF and U_R ≤ 100 VDC:

5000 s minimum value (15,000 s typical value)

For C > 3.3µF and U_R ≤ 100 VDC:

1250 s minimum value (10,000 s typical value)

CAPACITANCE DRIFT:

Up to + 40°C, ± 1.5% for a period of two years

DERATING FOR DC AND AC.

CATEGORY VOLTAGE U_C:

At + 85°C: U_C = 1.0 U_R

At + 100°C: U_C = 0.8 U_R

At + 125°C: U_C = 0.5 U_R (maximum 1000 h)

SELF INDUCTANCE:

~ 6 nH measured with 2mm long leads

PULL TEST ON LEADS:

≥ 30 N in direction of leads according to IEC 60068-2-21

RELIABILITY:

Operational life > 300,000 h

Failure rate < 2 FIT (40°C and 0.5 x U_R)

For further details, please refer to the general information provided in this catalog.

MAXIMUM PULSE RISE TIME

PCM (mm)	Maximum pulse rise time d _v / d _t [V/µs]				
	40 VDC	50 VDC	63 VDC	100 VDC	250 VDC
10	120	160	200	240	350

If the maximum pulse voltage is less than the rated voltage higher d_v/d_t values can be permitted.



DISSIPATION FACTOR TAN δ

MEASURED AT	$C \leq 0.1\mu\text{F}$	$0.1\mu\text{F} < C \leq 1.0\mu\text{F}$	$C > 1.0\mu\text{F}$
1kHz	8×10^{-3}	8×10^{-3}	10×10^{-3}
10kHz	15×10^{-3}	15×10^{-3}	—
100kHz	25×10^{-3}	—	—
Maximum values			

CAPACITANCE	CAPACITANCE CODE	VOLTAGE CODE 04 40 VDC/ 25 VAC			VOLTAGE CODE 05 50 VDC/ 30 VAC			VOLTAGE CODE 06 63 VDC/ 40 VAC			VOLTAGE CODE 01 100 VDC/ 63 VAC			VOLTAGE CODE 25* 250 VDC/ 160 VAC		
		W	H	L	W	H	L	W	H	L	W	H	L	W	H	L
1000 pF	- 210	—	—	—	—	—	—	—	—	—	2.5	6.5	7.2	2.5	6.5	7.2
1500 pF	- 215	—	—	—	—	—	—	—	—	—	2.5	6.5	7.2	2.5	6.5	7.2
2200 pF	- 222	—	—	—	—	—	—	—	—	—	2.5	6.5	7.2	2.5	6.5	7.2
3300 pF	- 233	—	—	—	—	—	—	—	—	—	2.5	6.5	7.2	2.5	6.5	7.2
4700 pF	- 247	—	—	—	—	—	—	—	—	—	2.5	6.5	7.2	2.5	6.5	7.2
6800 pF	- 268	—	—	—	—	—	—	—	—	—	2.5	6.5	7.2	2.5	6.5	7.2
0.01 μF	- 310	—	—	—	—	—	—	—	—	—	2.5	6.5	7.2	2.5	6.5	7.2
0.015 μF	- 315	—	—	—	—	—	—	—	—	—	2.5	6.5	7.2	2.5	6.5	7.2
0.022 μF	- 322	—	—	—	—	—	—	—	—	—	2.5	6.5	7.2	2.5	6.5	7.2
0.033 μF	- 333	—	—	—	—	—	—	—	—	—	2.5	6.5	7.2	3.0	7.5	7.2
0.047 μF	- 347	—	—	—	—	—	—	—	—	—	2.5	6.5	7.2	3.5	8.5	7.2
0.068 μF	- 368	—	—	—	—	—	—	—	—	—	2.5	6.5	7.2	4.5	9.5	7.2
0.10 μF	- 410	—	—	—	—	—	—	2.5	6.5	7.2	2.5	6.5	7.2	4.5	9.5	7.2
0.15 μF	- 415	—	—	—	—	—	—	2.5	6.5	7.2	3.0	7.5	7.2	5.5	11.5	7.2
0.22 μF	- 422	—	—	—	—	—	—	2.5	6.5	7.2	3.5	8.5	7.2	—	—	—
0.33 μF	- 433	—	—	—	—	—	—	3.0	7.5	7.2	4.5	9.5	7.2	—	—	—
0.47 μF	- 447	—	—	—	—	—	—	3.5	8.5	7.2	4.5	9.5	7.2	—	—	—
0.68 μF	- 468	—	—	—	—	—	—	4.5	9.5	7.2	5.5	11.5	7.2	—	—	—
1.0 μF	- 510	—	—	—	—	—	—	5.0	10.5	7.2	7.2	13.0	7.2	—	—	—
1.5 μF	- 515	—	—	—	5.5	11.5	7.2	—	—	—	—	—	—	—	—	—
2.2 μF	- 522	—	—	—	7.2	13.0	7.2	—	—	—	—	—	—	—	—	—
3.3 μF	- 533	—	—	—	7.2	13.0	7.2	—	—	—	—	—	—	—	—	—
4.7 μF^*	- 547	7.2	13.0	7.2	—	—	—	—	—	—	—	—	—	—	—	—

Further C-values on request.
*CECC approval in preparation.

RECOMMENDED PACKAGING

LETTER CODE	TYPE OF PACKAGING	HEIGHT (H) (mm)	REEL DIAMETER (mm)	ORDERING CODE EXAMPLE	PCM 10
ED	AMMO	16.5	S*	MKT 1826-533-055-ED	-
EG	AMMO	18.5	S*	MKT 1826-533-055-EG	-
EF	REEL	16.5	350	MKT 1826-533-055-EF	-
EW	REEL	18.5	350	MKT 1826-533-055-EW	-
E	BULK	—	—	MKT 1826-533-055-E	X

*S = box size 55 x 210 x 340mm (W x H x L).

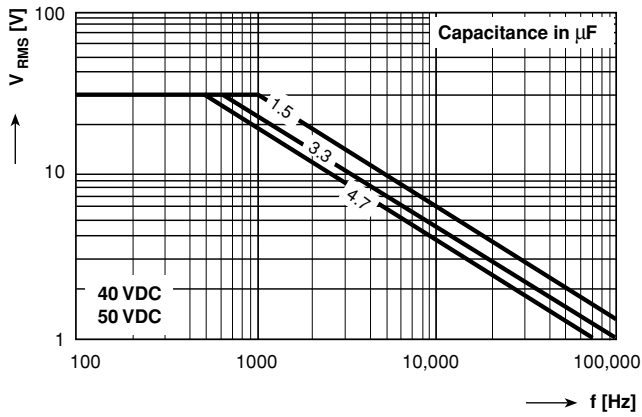

Permissible AC Voltage versus Frequency

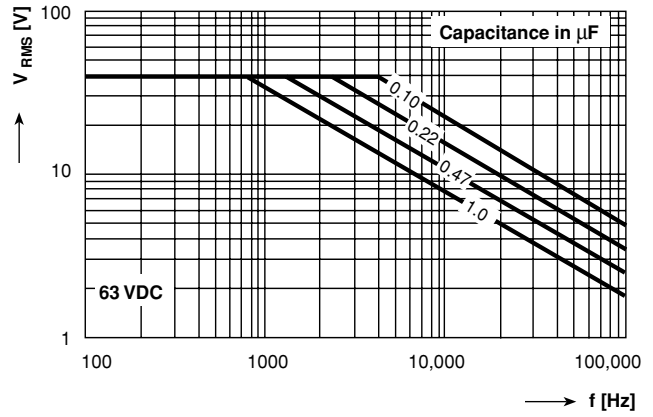

Permissible AC Voltage versus Frequency

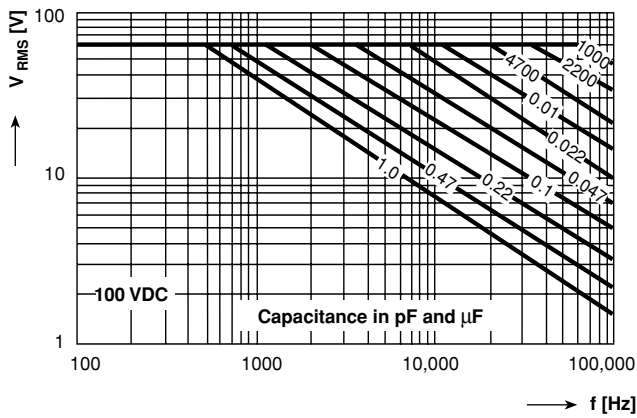

Permissible AC Voltage versus Frequency

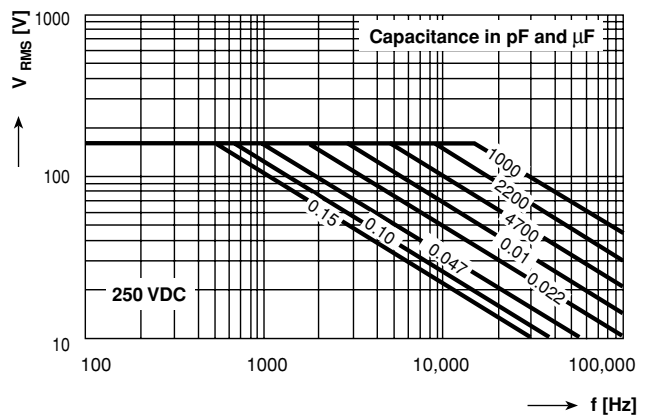

Permissible AC Voltage versus Frequency

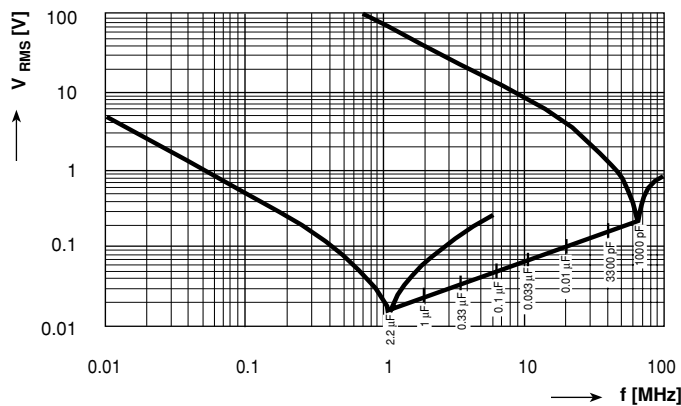

Impedance versus Frequency $Z = f(f)$
(Lead length 2.0mm)