

DASH NO. M CODE MADE FROM

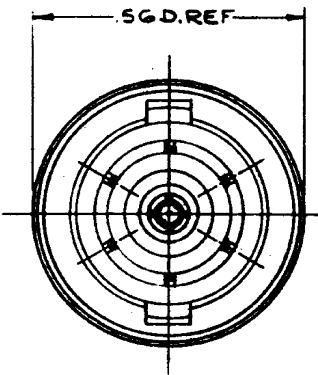
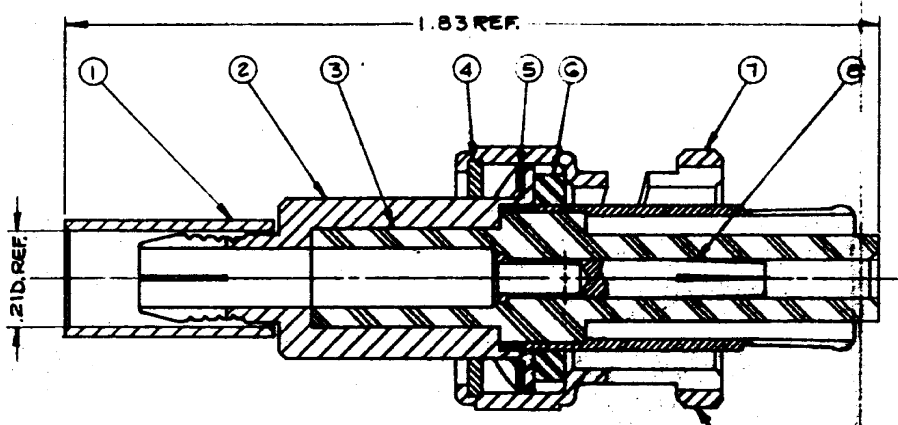

STAMP:
KINGS 1705-16-M06

- NOTES:
1. FOR USE WITH LASL TYPE C 9Y19503 CABLE.
 2. FOR CABLING INSTRUCTIONS SEE CP-441.
 3. FOR CABLE TRIMMING USE KTL-72 & KTD-136.
 4. FOR CRIMPING USE DIE SIZE 01.

UNLESS OTHERWISE SPECIFIED:

- | | |
|--|--|
| 1. TOLERANCES: FRACTIONS & 2 PLACE DECIMALS ± .010 | 2. REMOVE ALL BURRS, BREAK SHARP EDGES .005 MAX. |
| 3 PLACE DECIMALS ± .004 | 3. NO FILLETS PERMITTED. |
| T. I. R. CONCENTRICITY OF ANY 2 DIAMETERS MAY NOT EXCEED HALF THE SUM OF THEIR TOLERANCES. | 4. SURFACE ROUGHNESS 63 MICROINCHES RMS MAX. |
| | 5. ALL DIMENSIONS PRIOR TO PLATING. |

1705-16-M06 S-D

REVISIONS	
NO.	CHANGE
0	ER-18819 CXC 12 JUL 79
1	CN 19679 D GA 24 SEP 79

S-D

SCALE: 4:1

WAS E-8634

USED ON:

REF: SLAC P.O. NO. US915930M

FINISH: SPECKER-10004

MATL:

SPEC:

SHV PLUG

DRAWN CXC	DATE 19 JUL 79
APPR. GINO	DATE 20 JUL 79

KINGS ELECTRONICS
40 MARSHDALE ROAD
TUCKAHOE, N. Y. 10787

1705-16-M06

S-D