

SA5V0-G Thru. SA191-G Series

Working Peak Reverse Voltage: 5.0 to 190 Volts

Peak Pulse Power: 500 Watts

RoHS Device



Features

- Glass passivated chip.
- Low leakage.
- 500W peak pulse power capability with a 10/1000 μ s waveform, repetitive rate (duty cycle): 0.01%.
- Uni and Bidirectional unit.
- Excellent clamping capability.
- Very fast response time.
- RoHS compliant.

Mechanical data

- Case: Molded plastic DO-15
- Epoxy: UL 94V-0 rate flame retardant
- Terminals: Axial leads solderable per MIL-STD-202, Method 208
- Polarity: Color band denotes positive end (cathode)
- Mounting position: Any

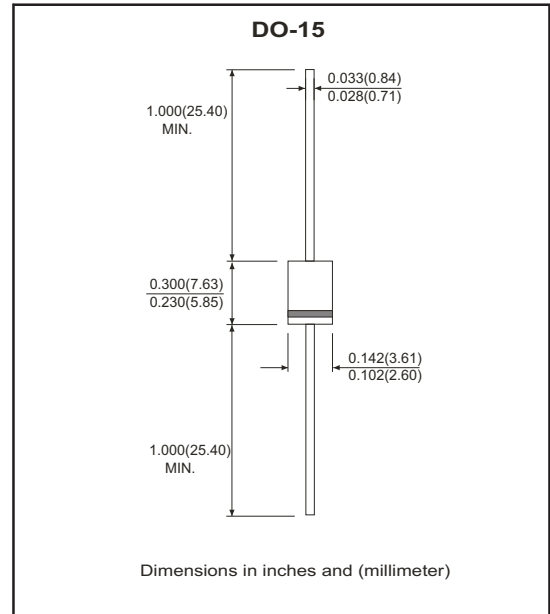

Maximum Ratings and Electrical Characteristics

Ratings at 25°C ambient temperature unless otherwise specified.
Single phase, half wave, 60Hz, resistive or inductive load.
For capacitive load, derate current by 20%.

Characteristics	Symbol	Value	Units
Peak power dissipation with a 10/1000 μ S waveform (Note 1)	P _{PP}	500	W
Peak pulse current with a 10/1000 μ S waveform (Note 1)	I _{PPM}	See Next Table	A
Power dissipation on infinite heatsink at T _L =75 °C	P _D	3.0	W
Peak forward surge current, 8.3ms single half sine-wave uni-directional only (Note 2)	I _{FSM}	70	A
Maximum instantaneous forward voltage at 25A for uni-directional only (Note 3)	V _F	3.5/5.0	V
Operating junction and storage temperature range	T _J , T _{STG}	-55 to +150	°C

NTOES:

- (1) Non-repetitive current pulse per fig.5 and derated above T_A=25°C per fig. 1.
- (2) Measured on 8.3 ms single half sine-wave or equivalent square wave,duty cycle=4 pulses per minute maximum.
- (3) V_F<3.5V for devices of V_{RR}≤200V and V_F<5.0V for devices of V_{RR}≥201V.

RATING AND CHARACTERISTIC CURVES (SA5V0-G thru SA191-G)

Fig.1 Pulse Derating Curve

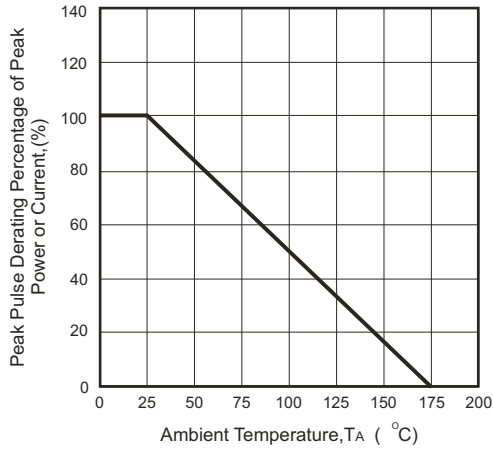

Fig.2 Maximum Non-Repetitive Surge Current

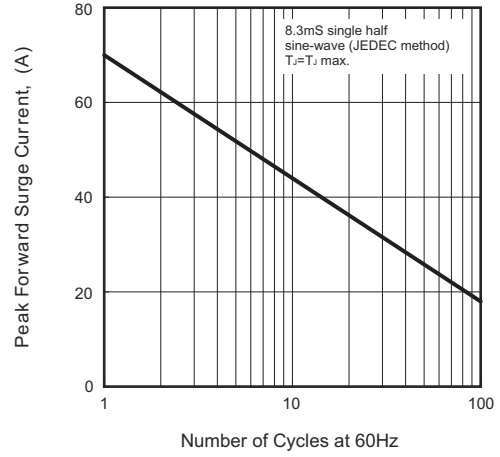

Fig.3 Steady State Power Derating Curve

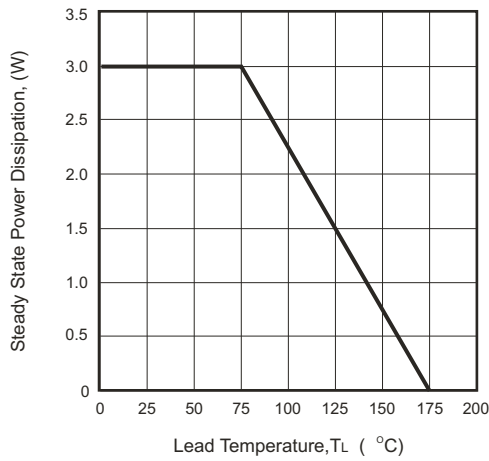

Fig.4 Peak Pulse Power Rating Curve

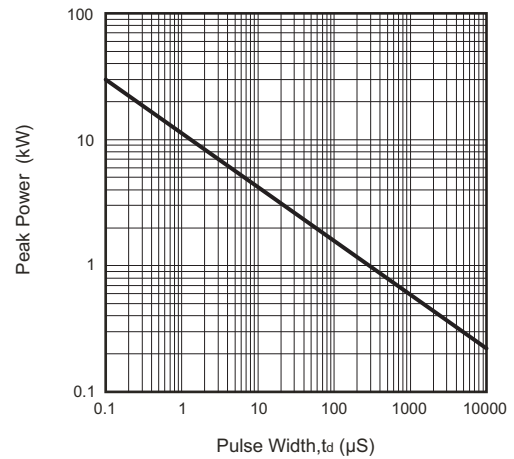

Fig.5 Pulse Waveform

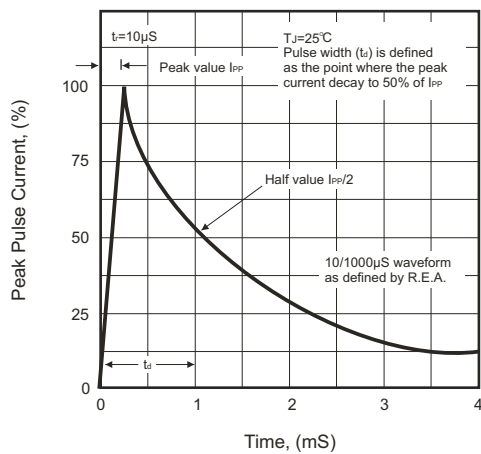
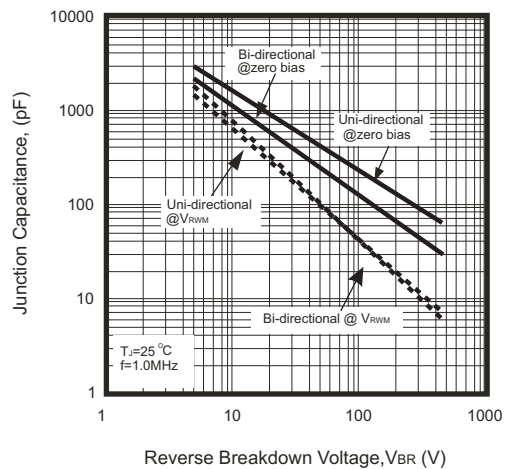

Fig.6 Typical Junction Capacitance



Axial Lead Transient Voltage Suppressor



Electrical Characteristics (SA5V0-G Thru. SA191-G)

Part No	Breakdown voltage V@ I _T			Maximum Reverse Leakage @VRWM IR (uA)	Working Peak Reverse Voltage VRWM (V)	Maximum Reverse Surge Current @ 10/1000us sinewave IPP (A)	Maximum Clamping Voltage @IPP Vc (V)	Marking Code	
	VBR Min. (V)	VBR Max. (V)	I _T (mA)					UNI	BI
SA5V0(C)-G	6.40	7.30	10	600	5.0	52.08	9.60	SA5.0	SA5.0C
SA5V0A(CA)-G	6.40	7.00	10	600	5.0	54.35	9.20	SA5.0A	SA5.0CA
SA6V0(C)-G	6.67	8.15	10	600	6.0	43.86	11.4	SA6.0	SA6.0C
SA6V0A(CA)-G	6.67	7.37	10	600	6.0	48.54	10.3	SA6.0A	SA6.0CA
SA6V5(C)-G	7.22	8.82	10	400	6.5	40.65	12.3	SA6.5	SA6.5C
SA6V5A(CA)-G	7.22	7.98	10	400	6.5	44.64	11.2	SA6.5A	SA6.5CA
SA7V0(C)-G	7.78	9.51	10	150	7.0	37.59	13.3	SA7.0	SA7.0C
SA7V0A(CA)-G	7.78	8.60	10	150	7.0	41.67	12.0	SA7.0A	SA7.0CA
SA7V5(C)-G	8.33	10.20	1	50	7.5	34.97	14.3	SA7.5	SA7.5C
SA7V5A(CA)-G	8.33	9.21	1	50	7.5	38.76	12.9	SA7.5A	SA7.5CA
SA8V0(C)-G	8.89	10.90	1	25	8.0	33.33	15.0	SA8.0	SA8.0C
SA8V0A(CA)-G	8.89	9.83	1	25	8.0	36.76	13.6	SA8.0A	SA8.0CA
SA8V5(C)-G	9.44	11.50	1	5	8.5	31.45	15.9	SA8.5	SA8.5C
SA8V5A(CA)-G	9.44	10.40	1	5	8.5	34.72	14.4	SA8.5A	SA8.5CA
SA9V0(C)-G	10.00	12.20	1	5	9.0	29.59	16.9	SA9.0	SA9.0C
SA9V0A(CA)-G	10.00	11.10	1	5	9.0	32.47	15.4	SA9.0A	SA9.0CA
SA100(C)-G	11.10	13.60	1	5	10.0	26.60	18.8	SA10	SA10C
SA100A(CA)-G	11.10	12.30	1	5	10.0	29.41	17.0	SA10A	SA10CA
SA110(C)-G	12.20	14.90	1	5	11.0	24.88	20.1	SA11	SA11C
SA110A(CA)-G	12.20	13.50	1	5	11.0	27.47	18.2	SA11A	SA11CA
SA120(C)-G	13.30	16.30	1	5	12.0	22.73	22.0	SA12	SA12C
SA120A(CA)-G	13.30	14.70	1	5	12.0	25.13	19.9	SA12A	SA12CA
SA130(C)-G	14.40	17.60	1	5	13.0	21.01	23.8	SA13	SA13C
SA130A(CA)-G	14.40	15.90	1	5	13.0	23.26	21.5	SA13A	SA13CA
SA140(C)-G	15.60	19.10	1	5	14.0	19.38	25.8	SA14	SA14C
SA140A(CA)-G	15.60	17.20	1	5	14.0	21.55	23.2	SA14A	SA14CA
SA150(C)-G	16.70	20.40	1	5	15.0	18.59	26.9	SA15	SA15C
SA150A(CA)-G	16.70	18.50	1	5	15.0	20.49	24.4	SA15A	SA15CA
SA160(C)-G	17.80	21.80	1	5	16.0	17.36	28.8	SA16	SA16C
SA160A(CA)-G	17.80	19.70	1	5	16.0	19.23	26.0	SA16A	SA16CA
SA170(C)-G	18.90	23.10	1	5	17.0	16.39	30.5	SA17	SA17C
SA170A(CA)-G	18.90	20.90	1	5	17.0	18.12	27.6	SA17A	SA17CA
SA180(C)-G	20.00	24.40	1	5	18.0	15.53	32.2	SA18	SA18C
SA180A(CA)-G	20.00	22.10	1	5	18.0	17.12	29.2	SA18A	SA18CA
SA190(C)-G	21.13	25.76	1	5	19.0	14.70	34.0	SA19	SA19C
SA190A(CA)-G	21.10	23.30	1	5	19.0	16.24	30.8	SA19A	SA19CA
SA200(C)-G	22.20	27.10	1	5	20.0	13.97	35.8	SA20	SA20C
SA200A(CA)-G	22.20	24.50	1	5	20.0	15.43	32.4	SA20A	SA20CA
SA220(C)-G	24.40	29.80	1	5	22.0	12.69	39.4	SA22	SA22C
SA220A(CA)-G	24.40	26.90	1	5	22.0	14.08	35.5	SA22A	SA22CA
SA240(C)-G	26.70	32.60	1	5	24.0	11.63	43.0	SA24	SA24C
SA240A(CA)-G	26.70	29.50	1	5	24.0	12.85	38.9	SA24A	SA24CA
SA260(C)-G	28.90	35.30	1	5	26.0	10.73	46.6	SA26	SA26C
SA260A(CA)-G	28.90	31.90	1	5	26.0	11.88	42.1	SA26A	SA26CA
SA280(C)-G	31.10	38.00	1	5	28.0	10.00	50.0	SA28	SA28C
SA280A(CA)-G	31.10	34.40	1	5	28.0	11.01	45.4	SA28A	SA28CA
SA300(C)-G	33.30	40.70	1	5	30.0	9.35	53.5	SA30	SA30C
SA300A(CA)-G	33.30	36.80	1	5	30.0	10.33	48.4	SA30A	SA30CA
SA330(C)-G	36.70	44.90	1	5	33.0	8.47	59.0	SA33	SA33C
SA330A(CA)-G	36.70	40.60	1	5	33.0	9.38	53.3	SA33A	SA33CA
SA360(C)-G	40.00	48.90	1	5	36.0	7.78	64.3	SA36	SA36C
SA360A(CA)-G	40.00	44.20	1	5	36.0	8.61	58.1	SA36A	SA36CA

Axial Lead Transient Voltage Suppressor

Electrical Characteristics (SA5V0-G Thru. SA191-G)

Part No	Breakdown voltage V@ I _T			Maximum Reverse Leakage @VRWM IR (μA)	Working Peak Reverse Voltage VRWM (V)	Maximum Reverse Surge Current @ 10/1000us sinewave IPP (A)	Maximum Clamping Voltage @IPP VC (V)	Marking Code	
	V _{BR} Min. (V)	V _{BR} Max. (V)	I _T (mA)					UNI	BI
SA400(C)-G	44.40	54.30	1	5	40.0	7.00	71.4	SA40	SA40C
SA400A(CA)-G	44.40	49.10	1	5	40.0	7.75	64.5	SA40A	SA40CA
SA430(C)-G	47.80	58.40	1	5	43.0	6.52	76.7	SA43	SA43C
SA430A(CA)-G	47.80	52.80	1	5	43.0	7.20	69.4	SA43A	SA43CA
SA450(C)-G	50.00	61.10	1	5	45.0	6.23	80.3	SA45	SA45C
SA450A(CA)-G	50.00	55.30	1	5	45.0	6.88	72.7	SA45A	SA45CA
SA480(C)-G	53.30	65.10	1	5	48.0	5.85	85.5	SA48	SA48C
SA480A(CA)-G	53.30	58.90	1	5	48.0	6.46	77.4	SA48A	SA48CA
SA510(C)-G	56.70	69.30	1	5	51.0	5.49	91.1	SA51	SA51C
SA510A(CA)-G	56.70	62.70	1	5	51.0	6.07	82.4	SA51A	SA51CA
SA540(C)-G	60.00	73.30	1	5	54.0	5.19	96.3	SA54	SA54C
SA540A(CA)-G	60.00	66.30	1	5	54.0	5.74	87.1	SA54A	SA54CA
SA580(C)-G	64.40	78.70	1	5	58.0	4.85	103.0	SA58	SA58C
SA580A(CA)-G	64.40	71.20	1	5	58.0	5.34	93.6	SA58A	SA58CA
SA600(C)-G	66.70	81.50	1	5	60.0	4.67	107.0	SA60	SA60C
SA600A(CA)-G	66.70	73.70	1	5	60.0	5.17	96.8	SA60A	SA60CA
SA640(C)-G	71.10	86.90	1	5	64.0	4.39	114.0	SA64	SA64C
SA640A(CA)-G	71.10	78.60	1	5	64.0	4.85	103.0	SA64A	SA64CA
SA700(C)-G	77.80	95.10	1	5	70.0	4.00	125.0	SA70	SA70C
SA700A(CA)-G	77.80	86.00	1	5	70.0	4.42	113.0	SA70A	SA70CA
SA750(C)-G	83.30	102.00	1	5	75.0	3.73	134.0	SA75	SA75C
SA750A(CA)-G	83.30	92.10	1	5	75.0	4.13	121.0	SA75A	SA75CA
SA780(C)-G	86.70	106.00	1	5	78.0	3.60	139.0	SA78	SA78C
SA780A(CA)-G	86.70	95.80	1	5	78.0	3.97	126.0	SA78A	SA78CA
SA800(C)-G	88.96	108.80	1	5	80.0	3.49	143.2	SA80	SA80C
SA800A(CA)-G	88.80	97.60	1	5	80.0	3.86	129.6	SA80A	SA80CA
SA850(C)-G	94.40	115.00	1	5	85.0	3.31	151.0	SA85	SA85C
SA850A(CA)-G	94.40	104.00	1	5	85.0	3.65	137.0	SA85A	SA85CA
SA900(C)-G	100.00	122.00	1	5	90.0	3.13	160.0	SA90	SA90C
SA900A(CA)-G	100.00	111.00	1	5	90.0	3.42	146.0	SA90A	SA90CA
SA101(C)-G	111.00	136.00	1	5	100.0	2.79	179.0	SA100	SA100C
SA101A(CA)-G	111.00	123.00	1	5	100.0	3.09	162.0	SA100A	SA100CA
SA111(C)-G	122.00	149.00	1	5	110.0	2.55	196.0	SA110	SA110C
SA111A(CA)-G	122.00	135.00	1	5	110.0	2.82	177.0	SA110A	SA110CA
SA121(C)-G	133.00	163.00	1	5	120.0	2.34	214.0	SA120	SA120C
SA121A(CA)-G	133.00	147.00	1	5	120.0	2.59	193.0	SA120A	SA120CA
SA131(C)-G	144.00	176.00	1	5	130.0	2.16	231.0	SA130	SA130C
SA131A(CA)-G	144.00	159.00	1	5	130.0	2.39	209.0	SA130A	SA130CA
SA141(C)-G	155.68	190.40	1	5	140.0	2.00	250.6	SA140	SA140C
SA141A(CA)-G	155.00	171.00	1	5	140.0	2.20	226.8	SA140A	SA140CA
SA151(C)-G	167.00	204.00	1	5	150.0	1.87	268.0	SA150	SA150C
SA151A(CA)-G	167.00	185.00	1	5	150.0	2.06	243.0	SA150A	SA150CA
SA161(C)-G	178.00	218.00	1	5	160.0	1.74	287.0	SA160	SA160C
SA161A(CA)-G	178.00	197.00	1	5	160.0	1.93	259.0	SA160A	SA160CA
SA171(C)-G	189.00	231.00	1	5	170.0	1.64	304.0	SA170	SA170C
SA171A(CA)-G	189.00	209.00	1	5	170.0	1.82	275.0	SA170A	SA170CA
SA181(C)-G	200.16	244.80	1	5	180.0	1.55	322.2	SA180	SA180C
SA181A(CA)-G	200.00	220.00	1	5	180.0	1.71	291.6	SA180A	SA180CA

Axial Lead Transient Voltage Suppressor

Electrical Characteristics (SA5V0-G Thru. SA191-G)

Part No	Breakdown voltage V@ I _T			Maximum Reverse Leakage @VRWM IR (uA)	Working Peak Reverse Voltage VRWM (V)	Maximum Reverse Surge Current @ 10/1000us sinewave IPP (A)	Maximum Clamping Voltage @IPP VC (V)	Marking Code	
	V _{BR} Min. (V)	V _{BR} Max. (V)	I _T (mA)					UNI	BI
SA191(C)-G	211.28	258.40	1	5	190.0	1.47	340.1	SA190	SA190C
SA191A(CA)-G	211.00	232.00	1	5	190.0	1.62	307.8	SA190A	SA190CA

Note:

- 1) Suffix 'A' denotes 5% tolerance devices. Without 'A' denotes 10% tolerance devices.
- 2) Add Suffix 'C' or 'CA' after part number to specify Bi-directional devices.
- 3) For Bi-Directional devices having V_R of 10 volts and under, the I_R limit is double.

Taping Specification For Axial Lead Diodes(For Reel Package)

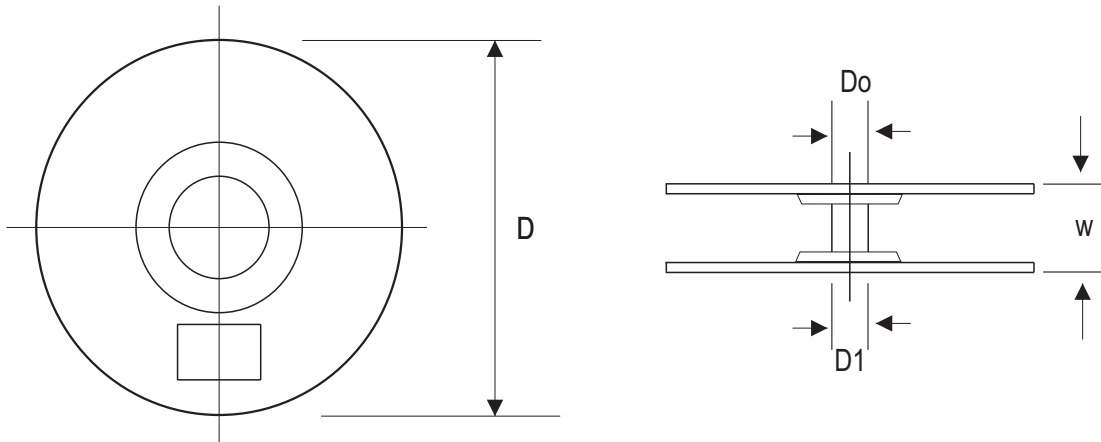
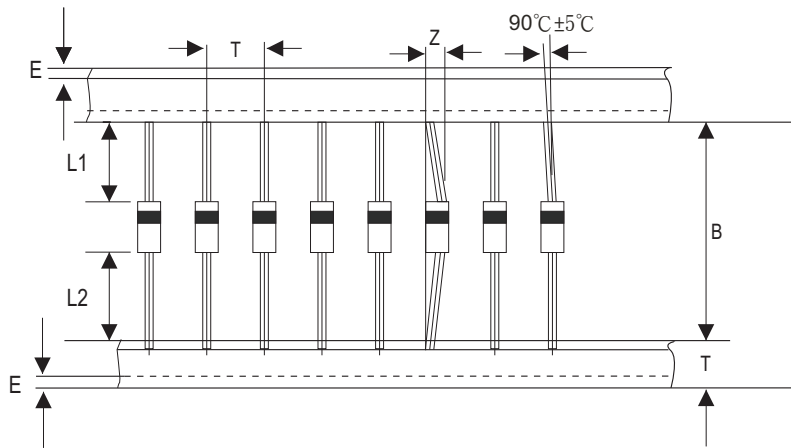

DO-15	SYMBOL	A	B	Z	T	E	L1-L2	D
	(mm)	5.00 ± 0.5	52.0 ± 0.5	1.2 (max)	6.0 ± 0.4	3 (max)	1.0 (max)	330
	(inch)	0.197 ± 0.020	2.047 ± 0.020	0.047 (max)	0.236 ± 0.016	0.118 (max)	0.039 (max)	13

DO-15	SYMBOL	D1	D0	W			
	(mm)	85.7 ± 0.3	16.6 ± 0.4	72.0 ± 3.0			
	(inch)	3.374 ± 0.012	0.654 ± 0.016	2.835 ± 0.118			

Standard Packaging

Case Type	REEL PACK	
	REEL (pcs)	Reel Size (inch)
DO-15	4,000	13

Taping Specification For Axial Lead Diodes (For Ammo Package)

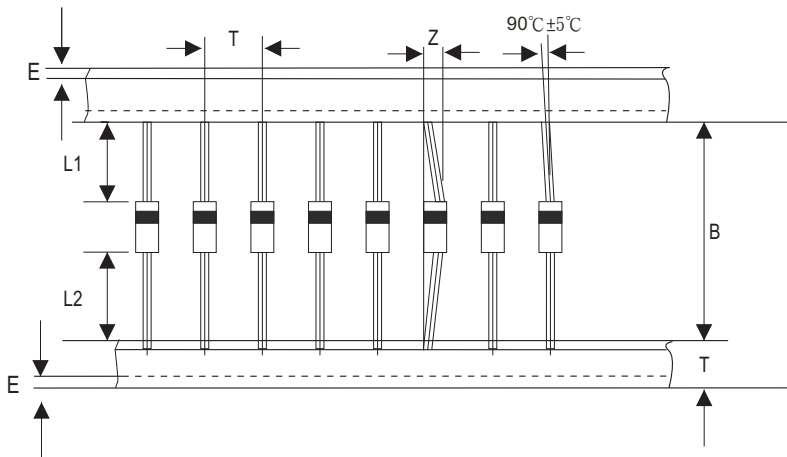

DO-15	SYMBOL	A	B	Z	T	E	L1-L2	
	(mm)	5.00 ± 0.5	52.0 ± 0.5	1.2 (max)	6.0 ± 0.4	3 (max)	1.0 (max)	
	(inch)	0.197 ± 0.020	2.047 ± 0.020	0.047 (max)	0.236 ± 0.016	0.118 (max)	0.039 (max)	

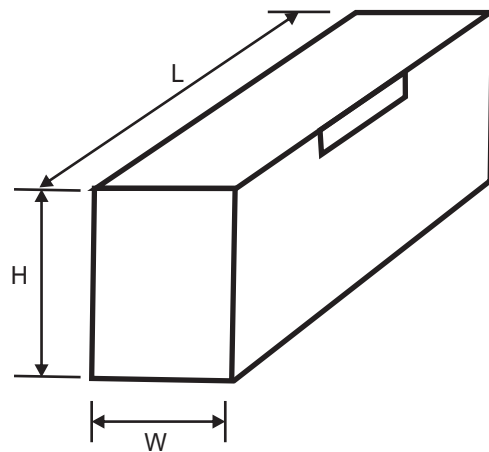

Standard Packaging

Case Type	Ammo Package			
	Inner BOX Dimension (L*W*H)	Inner BOX (K)	Box / Carton (EA)	CARTON (K)
DO-15	252*80*117	2	10	20
	260*75*145	3	10	30