

< High-power GaAs FET (small signal gain stage)>

MGF0906B

L & S BAND / 5W
non - matched

DESCRIPTION

The MGF0906B, GaAs FET with an N-channel schottky gate, is designed for use in UHF band amplifiers.

FEATURES

- Class A operation
- High output power
P1dB=37.0dBm(TYP.) @f=2.3GHz
- High power gain
GLP=11.0dB(TYP.) @f=2.3GHz
- High power added efficiency
P.A.E =40%(TYP.) @f=2.3GHz,P1dB
- Hermetically sealed metal-ceramic package with ceramic lid

APPLICATION

- For UHF Band power amplifiers

QUALITY

- IG

RECOMMENDED BIAS CONDITIONS

- Vds=10V • Ids=1.2A • Rg=100Ω Refer to Bias Procedure

Absolute maximum ratings (Ta=25°C)

Symbol	Parameter	Ratings	Unit
VGDO	Gate to drain voltage	-15	V
VGSO	Gate to source voltage	-15	V
ID	Drain current	3	A
IGR	Reverse gate current	-10	mA
IGF	Forward gate current	21	mA
PT*1	Total power dissipation	23	W
Tch	Channel temperature	175	°C
Tstg	Storage temperature	-65 to +175	°C

*1:Tc=25°C

Electrical characteristics (Ta=25°C)

Symbol	Parameter	Test conditions	Limits			Unit
			Min.	Typ.	Max.	
IDSS	Saturated drain current	VDS=3V,VGS=0V	-	2	3	A
gm	Transconductance	VDS=3V,ID=1.1A	-	1	-	S
VGS(off)	Gate to source cut-off voltage	VDS=3V,ID=10mA	-1	-2.5	-4	V
P1dB	Output power at 1dB gain compression	VDS=10V,ID(RF off)=1.2A f=2.3GHz	35.5	37	-	dBm
GLP	Linear Power Gain		10	11	-	dB
ID	Drain current		-	1.1	1.5	A
P.A.E.	Power added efficiency		-	40	-	%
Rth(ch-c) *2	Thermal resistance	ΔVf method	-	-	6.5	°C/W

*2 :Channel-case

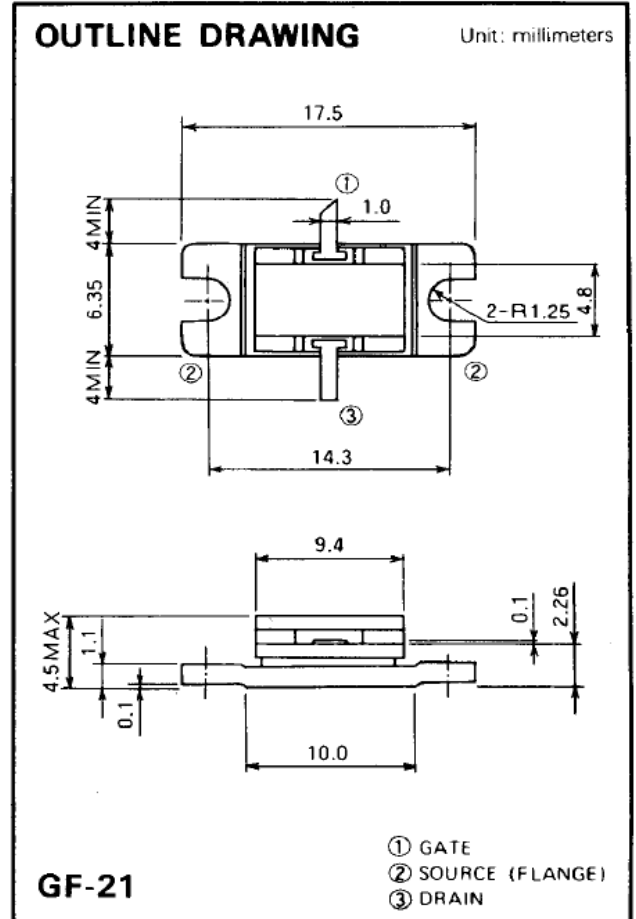

MGF0906B

L & S BAND / 5W

non - matched

MGF0906B TYPICAL CHARACTERISTICS (Ta=25deg.C)

ID vs. VGS

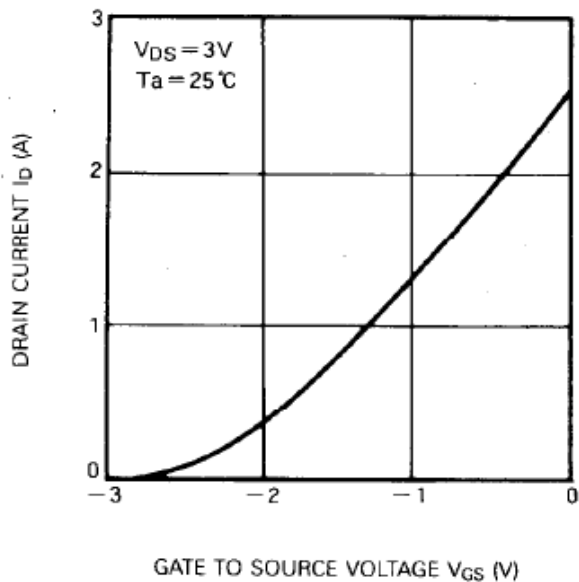

ID vs. VDS

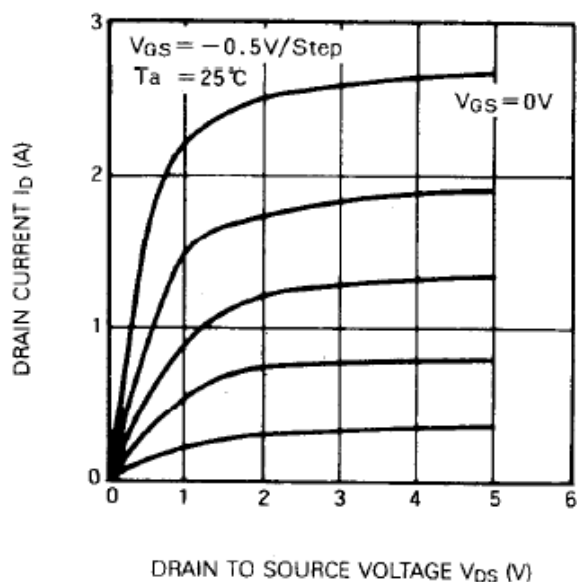

Po, PAE vs. Pin (f=2.3GHz)

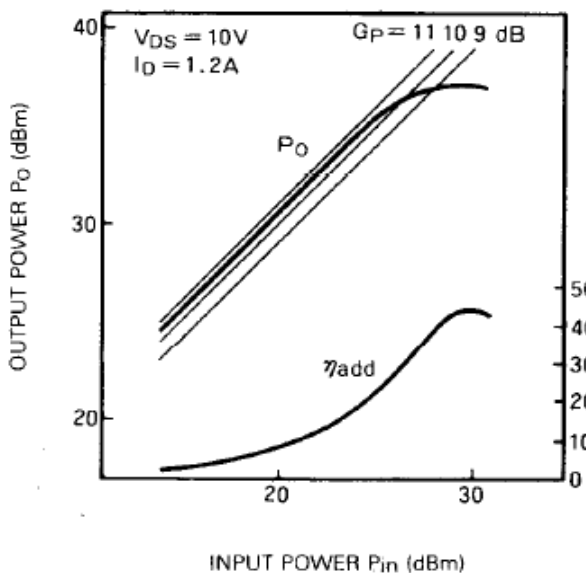

GLP, P1dB, ID, PAE vs. VDS (f=2.3GHz)

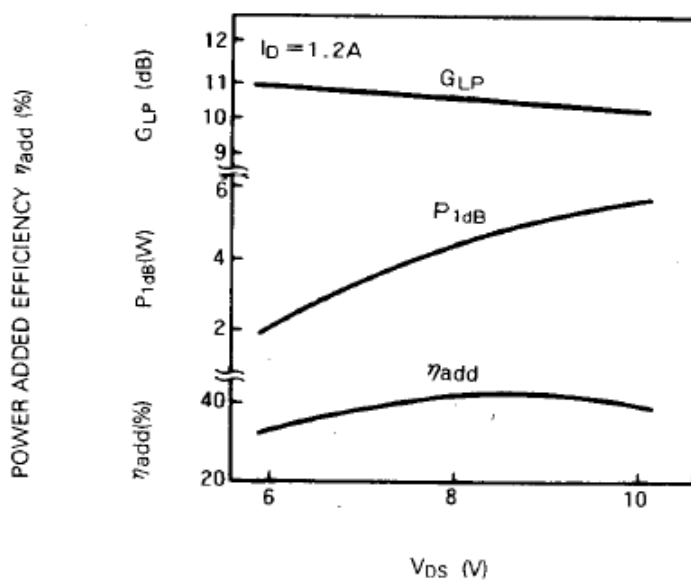

< High-power GaAs FET (small signal gain stage) >

MGF0906B

L & S BAND / 5W

non - matched

MGF0906B S-parameters (Ta=25deg.C , VDS=10(V), IDS=1.2(A))

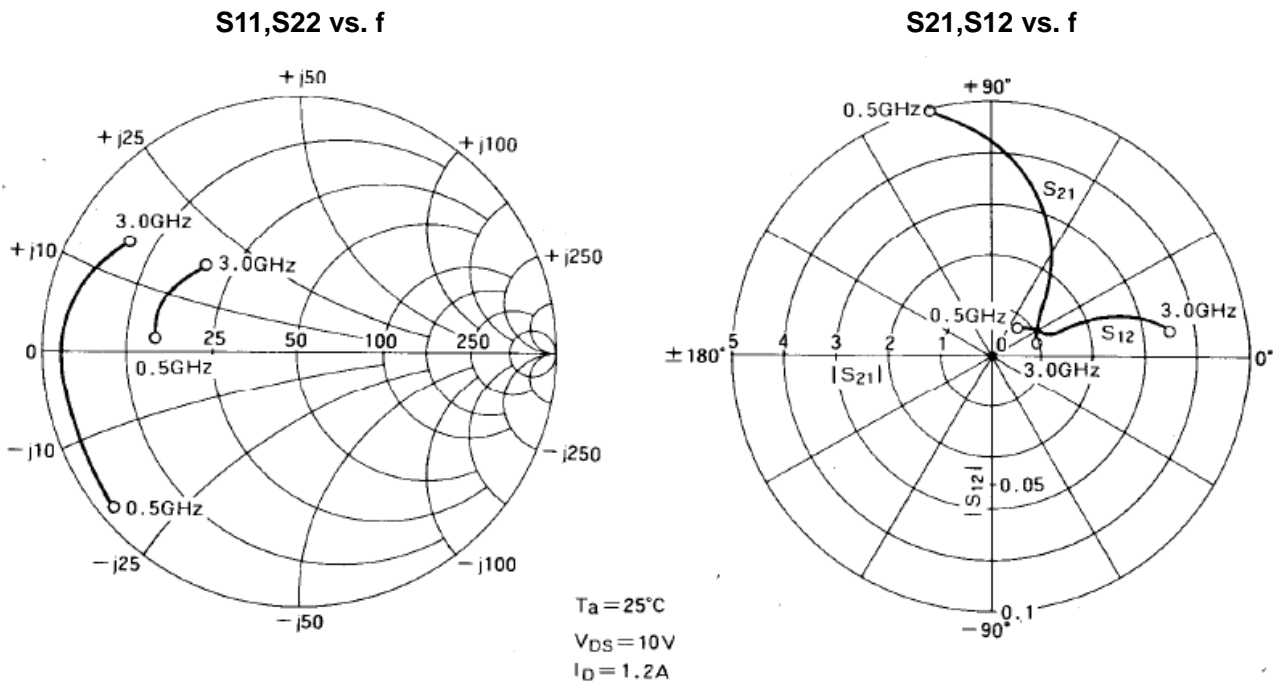

f (GHz)	S ₁₁		S ₂₁		S ₁₂		S ₂₂		K	MSG/MAG (dB)
	Magn.	Ang. (deg.)	Magn.	Ang. (deg.)	Magn.	Ang. (deg.)	Magn.	Ang. (deg.)		
0.5	0.922	-139.9	4.997	104.1	0.016	51.5	0.673	174.9	0.869	25.0
0.6	0.913	-146.2	4.570	97.5	0.019	44.9	0.674	172.5	0.837	23.8
0.7	0.906	-151.8	4.176	91.5	0.022	39.3	0.676	170.4	0.807	22.8
0.8	0.900	-156.8	3.815	85.9	0.023	34.6	0.677	168.6	0.826	22.1
0.9	0.896	-161.2	3.484	80.9	0.025	30.7	0.679	167.0	0.819	21.4
1.0	0.894	-165.0	3.182	76.3	0.026	27.7	0.680	165.7	0.834	20.9
1.1	0.892	-168.4	2.909	72.2	0.026	25.2	0.680	164.5	0.883	20.5
1.2	0.891	-171.4	2.662	68.3	0.027	23.4	0.681	163.5	0.906	19.9
1.3	0.891	-174.0	2.440	64.8	0.027	22.1	0.681	162.6	0.959	19.6
1.4	0.891	-176.3	2.242	61.6	0.027	21.3	0.680	161.8	1.024	18.2
1.5	0.892	-178.3	2.067	58.7	0.027	20.9	0.679	161.1	1.086	17.1
1.6	0.892	-179.9	1.913	55.9	0.027	20.7	0.678	160.5	1.160	16.1
1.7	0.892	-178.2	1.779	53.2	0.028	20.8	0.676	159.8	1.202	15.3
1.8	0.892	-176.6	1.664	50.7	0.028	21.0	0.673	159.2	1.285	14.5
1.9	0.891	-175.1	1.565	48.2	0.029	21.3	0.670	158.6	1.334	13.9
2.0	0.890	-173.6	1.482	45.8	0.030	21.6	0.666	157.9	1.384	13.2
2.1	0.887	-172.0	1.414	43.4	0.031	21.9	0.661	157.1	1.455	12.6
2.2	0.883	-170.2	1.359	40.8	0.033	21.9	0.655	156.3	1.487	12.0
2.3	0.877	-168.3	1.315	38.2	0.035	21.8	0.649	155.3	1.538	11.4
2.4	0.870	-166.2	1.282	35.4	0.038	21.3	0.642	154.1	1.553	10.9
2.5	0.861	-163.8	1.258	32.5	0.042	20.5	0.633	152.8	1.554	10.4
2.6	0.850	-161.1	1.241	29.3	0.046	19.2	0.624	151.3	1.569	9.9
2.7	0.837	-157.9	1.231	25.8	0.051	17.4	0.614	149.5	1.569	9.4
2.8	0.821	-154.4	1.226	22.0	0.057	15.0	0.602	147.5	1.566	8.9
2.9	0.803	-150.3	1.224	17.9	0.064	11.9	0.589	145.1	1.566	8.4
3.0	0.781	-145.6	1.224	13.4	0.072	8.0	0.576	142.5	1.549	7.9

Keep safety first in your circuit designs!

Mitsubishi Electric Corporation puts the maximum effort into making semiconductor products better and more reliable, but there is always the possibility that trouble may occur with them. Trouble with semiconductors may lead to personal injury, fire or property damage. Remember to give due consideration to safety when making your circuit designs, with appropriate measures such as (i) placement of substitutive, auxiliary circuits, (ii) use of non-flammable material or (iii) prevention against any malfunction or mishap.

Notes regarding these materials

- These materials are intended as a reference to assist our customers in the selection of the Mitsubishi semiconductor product best suited to the customer's application; they do not convey any license under any intellectual property rights, or any other rights, belonging to Mitsubishi Electric Corporation or a third party.
- Mitsubishi Electric Corporation assumes no responsibility for any damage, or infringement of any third-party's rights, originating in the use of any product data, diagrams, charts, programs, algorithms, or circuit application examples contained in these materials.
- All information contained in these materials, including product data, diagrams, charts, programs and algorithms represents information on products at the time of publication of these materials, and are subject to change by Mitsubishi Electric Corporation without notice due to product improvements or other reasons. It is therefore recommended that customers contact Mitsubishi Electric Corporation or an authorized Mitsubishi Semiconductor product distributor for the latest product information before purchasing a product listed herein.

The information described here may contain technical inaccuracies or typographical errors. Mitsubishi Electric Corporation assumes no responsibility for any damage, liability, or other loss rising from these inaccuracies or errors.

Please also pay attention to information published by Mitsubishi Electric Corporation by various means, including the Mitsubishi Semiconductor home page (<http://www.MitsubishiElectric.com/>).

- When using any or all of the information contained in these materials, including product data, diagrams, charts, programs, and algorithms, please be sure to evaluate all information as a total system before making a final decision on the applicability of the information and products. Mitsubishi Electric Corporation assumes no responsibility for any damage, liability or other loss resulting from the information contained herein.
- Mitsubishi Electric Corporation semiconductors are not designed or manufactured for use in a device or system that is used under circumstances in which human life is potentially at stake. Please contact Mitsubishi Electric Corporation or an authorized Mitsubishi Semiconductor product distributor when considering the use of a product contained herein for any specific purposes, such as apparatus or systems for transportation, vehicular, medical, aerospace, nuclear, or undersea repeater use.
- The prior written approval of Mitsubishi Electric Corporation is necessary to reprint or reproduce in whole or in part these materials.
- If these products or technologies are subject to the Japanese export control restrictions, they must be exported under a license from the Japanese government and cannot be imported into a country other than the approved destination.
Any diversion or re-export contrary to the export control laws and regulations of Japan and/or the country of destination is prohibited.
- Please contact Mitsubishi Electric Corporation or an authorized Mitsubishi Semiconductor product distributor for further details on these materials or the products contained therein.