

RoHS Compliant Product

A suffix of "-C" specifies halogen & lead-free

FEATURES

- Low Turn-on Voltage
- Extremely Fast Switching Speed
- PN Junction Guard Ring for Transient and ESD Protection

MECHANICAL DATA

- Case: SOD-323, Molded Plastic
- Polarity: See Diagrams Below
- Mounting Position : Any
- Low Forward Voltage : 0.35 Volts (Typ) @ $I_F = 10 \text{ mAdc}$
- Shipping : 3000 / Tape & Reel

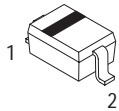

PIN 1. CATHODE
2. ANODE



BAT54H Marking : JV Δ ,
L4

PACKAGE DIMENSIONS

SOD-323
PLASTIC PACKAGE

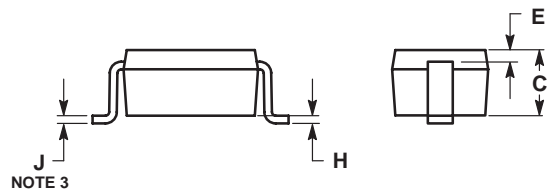
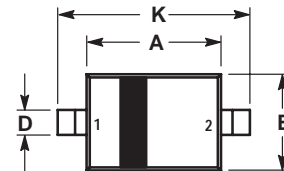

NOTE 3

NOTES:

1. DIMENSIONING AND TOLERANCING PER ANSI Y14.5M, 1982.
2. CONTROLLING DIMENSION: MILLIMETERS.
3. LEAD THICKNESS SPECIFIED PER L/F DRAWING WITH SOLDER PLATING.

MAXIMUM RATINGS ($T_J = 125^\circ\text{C}$ unless otherwise noted)

Symbol	Rating	Value	Unit
V_R	Reverse Voltage	30	V

THERMAL CHARACTERISTICS

Symbol	Characteristic	Max	Unit
P_D	Total Device Dissipation FR-5 Board,* $T_A = 25^\circ\text{C}$ Derate above 25°C	200 1.57	mW mW/ $^\circ\text{C}$
$R_{\theta JA}$	Thermal Resistance Junction to Ambient	635	$^\circ\text{C}/\text{W}$
T_J, T_{stg}	Junction and Storage Temperature	150	$^\circ\text{C}$

*FR-4 Minimum Pad

DIM	MILLIMETERS		INCHES	
	MIN	MAX	MIN	MAX
A	1.60	1.80	0.063	0.071
B	1.15	1.35	0.045	0.053
C	0.80	1.00	0.031	0.039
D	0.25	0.40	0.010	0.016
E	0.15 REF		0.006 REF	
H	0.00	0.10	0.000	0.004
J	0.089	0.177	0.0035	0.0070
K	2.30	2.70	0.091	0.106

ELECTRICAL CHARACTERISTICS ($T_A = 25^\circ\text{C}$ unless otherwise noted)

Characteristic	Symbol	Min	Typ	Max	Unit
Reverse Breakdown Voltage ($I_R = 10 \mu\text{A}$)	$V_{(BR)R}$	30	—	—	Volts
Total Capacitance ($V_R = 1.0 \text{ V}, f = 1.0 \text{ MHz}$)	C_T	—	7.6	10	pF
Reverse Leakage ($V_R = 25 \text{ V}$)	I_R	—	0.5	2.0	μAdc
Forward Voltage ($I_F = 0.1 \text{ mAdc}$)	V_F	—	0.22	0.24	Vdc
Forward Voltage ($I_F = 30 \text{ mAdc}$)	V_F	—	0.41	0.5	Vdc
Forward Voltage ($I_F = 100 \text{ mAdc}$)	V_F	—	0.52	1.0	Vdc
Reverse Recovery Time ($I_F = I_R = 10 \text{ mAdc}, I_{R(REC)} = 1.0 \text{ mAdc}$) Figure 1	t_{rr}	—	—	5.0	ns
Forward Voltage ($I_F = 1.0 \text{ mAdc}$)	V_F	—	0.29	0.32	Vdc
Forward Voltage ($I_F = 10 \text{ mAdc}$)	V_F	—	0.35	0.40	Vdc
Forward Current (DC)	I_F	—	—	200	mAdc
Repetitive Peak Forward Current	I_{FRM}	—	—	300	mAdc
Non-Repetitive Peak Forward Current ($t < 1.0 \text{ s}$)	I_{FSM}	—	—	600	mAdc

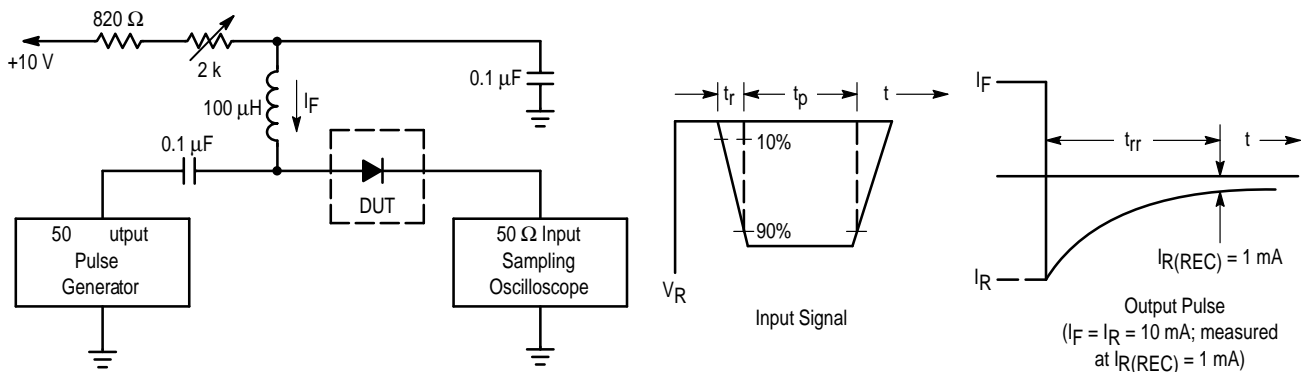

- Notes: 1. A 2.0 kΩ variable resistor adjusted for a Forward Current (I_F) of 10 mA.
2. Input pulse is adjusted so $I_{R(\text{peak})}$ is equal to 10 mA.
3. $t_p \gg t_{rr}$

Figure 1. Recovery Time Equivalent Test Circuit

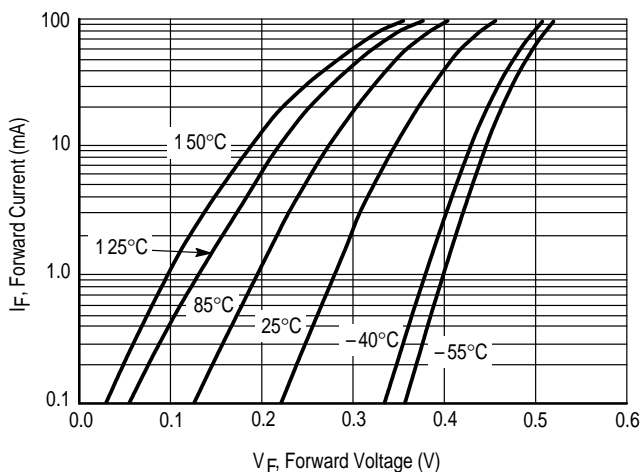

Figure 2. Forward Voltage

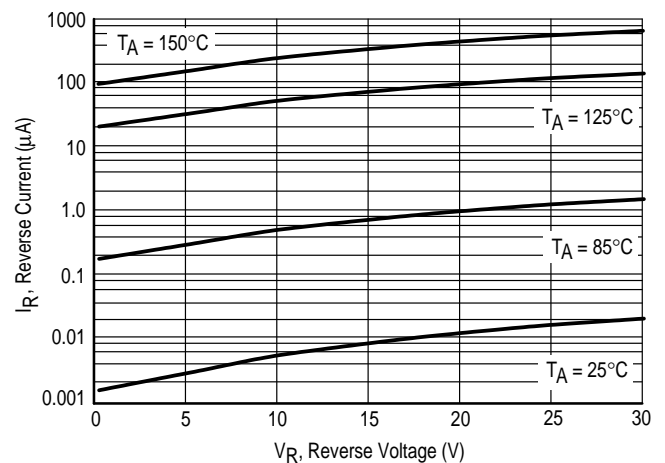

Figure 3. Leakage Current

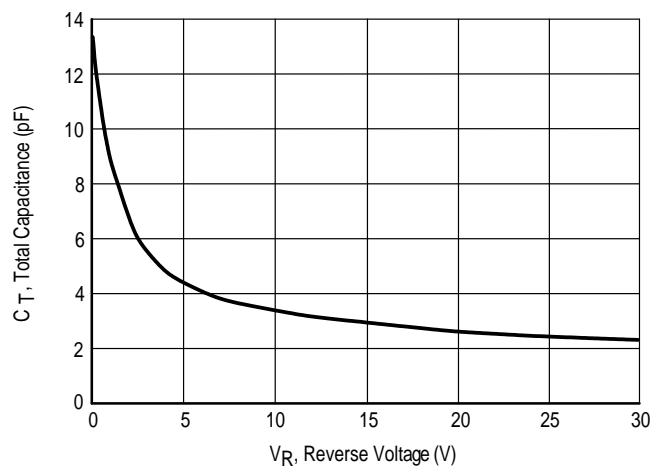

Figure 4. Total Capacitance