

GP4558

DUAL OPERATIONAL AMPLIFIER

Description

The GP4558 is a monolithic integrated circuit designed for dual operational amplifier.

Features

- No frequency compensated required
- No latch-up
- Large common mode and differential voltage range
- Parameter tracking over temperature range
- Gain and phase match between amplifiers
- Internally frequency compensated
- Low noise input transistors

Package Dimensions

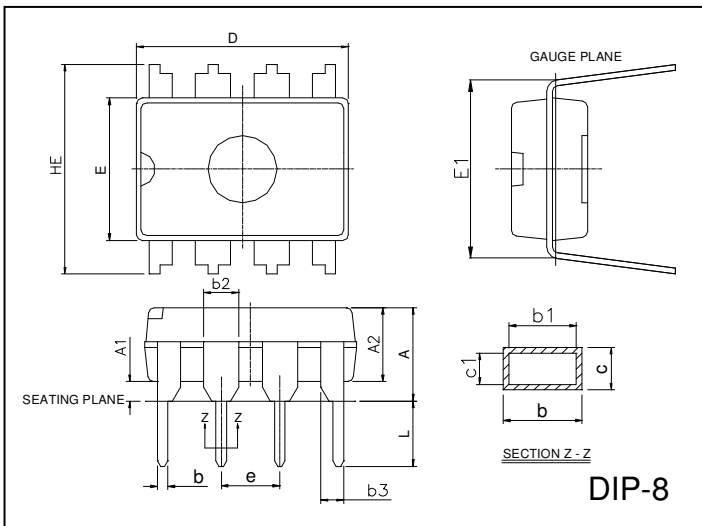

Marking :

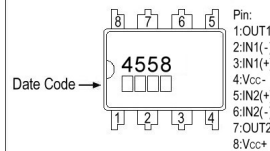

REF.	Millimeter		REF.	Millimeter	
	Min.	Max.		Min.	Max.
A	-	0.5334	c1	0.203	0.279
A1	0.381	-	D	9.017	10.16
A2	2.921	4.953	E	6.096	7.112
b	0.356	0.559	E1	7.620	8.255
b1	0.356	0.508	e	2.540 BSC	
b2	1.143	1.778	HE	-	10.92
b3	0.762	1.143	L	2.921	3.810
c	0.203	0.356			

Pin Configurations

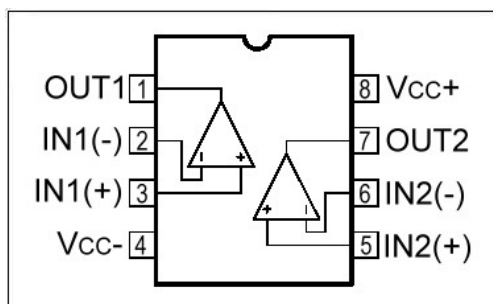

Block Diagram

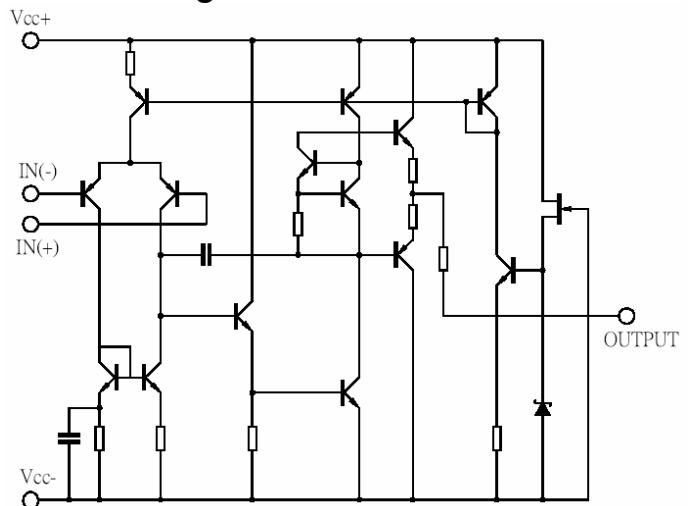

Absolute Maximum Ratings at Ta = 25°C

Parameter	Symbol	VALUE	Unit
Supply Voltage	VCC	±22	V
Differential Input Voltage	VI(DIFF)	±18	V
Input Voltage	VI	±15	V
Power Dissipation	PD	600	mW
Operating Temperature Range	TOPR	0 ~ +70	°C
Storage Temperature Range	TSTG	-65 ~ +150	°C

Electrical Characteristics (VCC=15V Vee=-15V, TA=25°C)

Parameter	SYMBOL	Test Conditions	Min	Typ.	Max	Unit
Supply Current, all Amp, no load	ICC		-	2.3	4.5	mA
Input Offset Voltage	VIO	Rs<10kΩ	-	2	6	mV
Input Offset Current	IIO		-	5	200	nA
Input Bias Current	IBIAS		-	30	500	nA
Common Mode Input Voltage	VI(R)		±12	±13		V
Large Signal Voltage Gain	GV	VO(P-P)=±10V, RL≤2kΩ	20	200	-	V/mV
Output Voltage Swing	VO(P-P)	RL≥10kΩ	-	±12	±14	V
Common Mode Rejection Ratio	CMRR	Rs≤10kΩ	70	90	-	dB
Supply Voltage Rejection Ratio	PSRR	Rs≤10kΩ	76	90	-	dB
Power Consumption	Pc		-	70	170	mV
Slew Rate	SR	Vi=±10V, RL≥2kΩ, CL≤100pF	1.2	2.2	-	V/μs
Rise Time	TRIS	Vi=±20mV, RL≥2kΩ, CL≤100pF	-	0.3	-	μs
Overshoot	OS	Vi=±20mV, RL≥2kΩ, CL≤100pF	-	15	-	%
Input Resistance	Ri		0.3	2	-	MΩ
Output Resistance	Ro		-	75	-	Ω
Total Harmonic Distortion	THD	f=1kHz, Av=20dB, RL=2kΩ, VO= 2VPP, CL=100pF	-	0.008	-	%
Channel Separation	Vo1/Vo2		-	120	-	dB

Frequency Characteristics (VCC=15V Vee=-15V, TA=25°C)

Parameter	SYMBOL	Test Conditions	Min	Typ.	Max	Unit
Unity Gain Bandwidth	BW		2.0	2.8	-	MHz

Typical Performance Characteristics

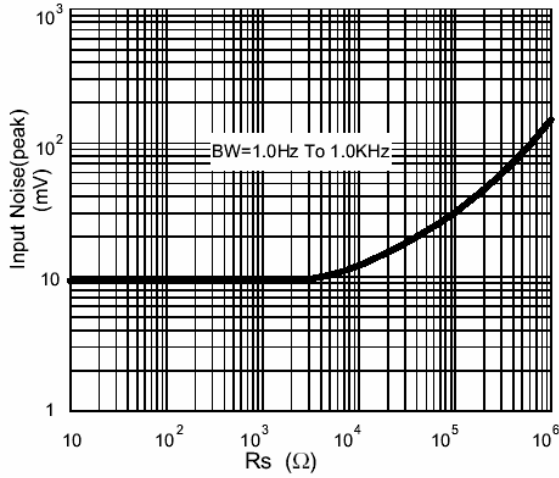

Fig 1. Burst Noise vs. Rs

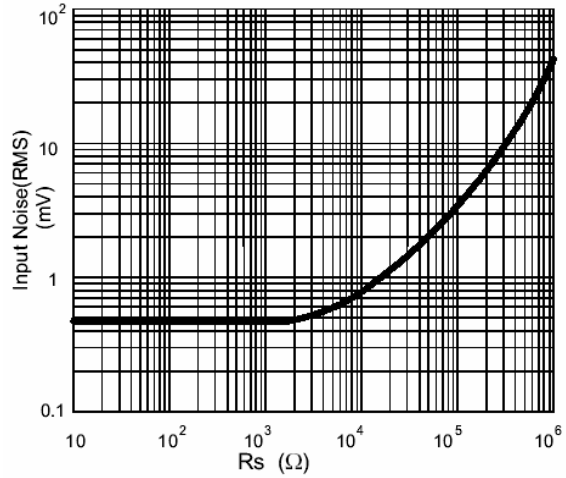

Fig 2. RMS Noise vs. Rs

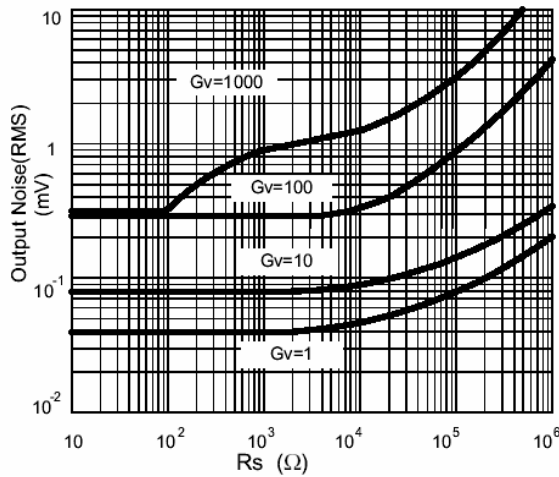

Fig 3. Output Noise vs. Rs

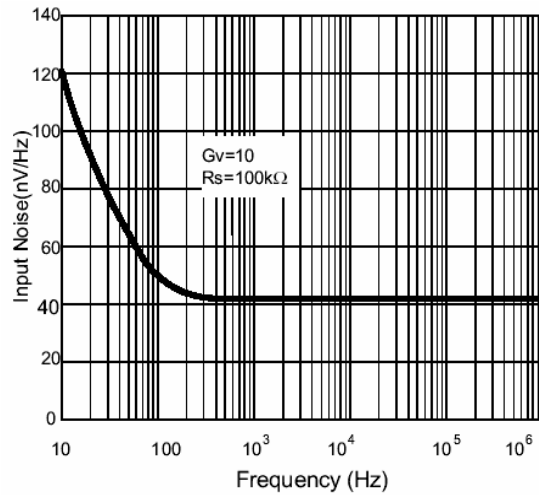

Fig 4. Spectral Noise vs. Density

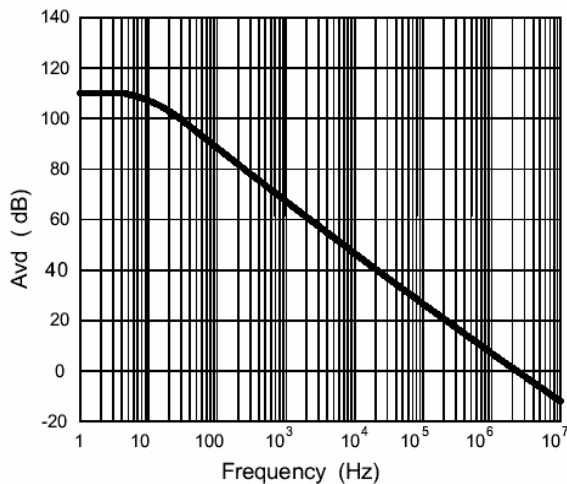

Fig 5. Open Loop Frequency Response

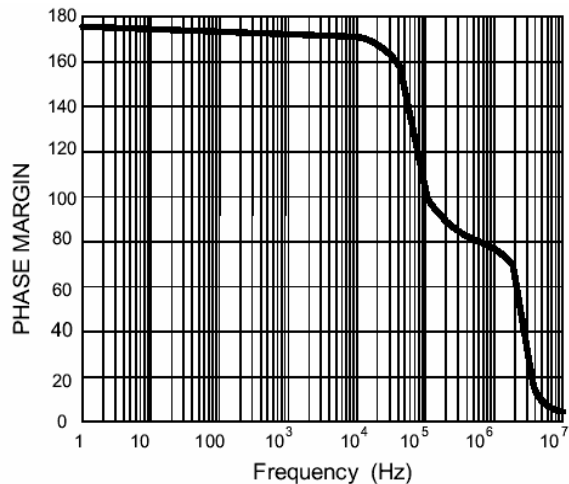

Fig 6. Phase Margin vs. Frequency

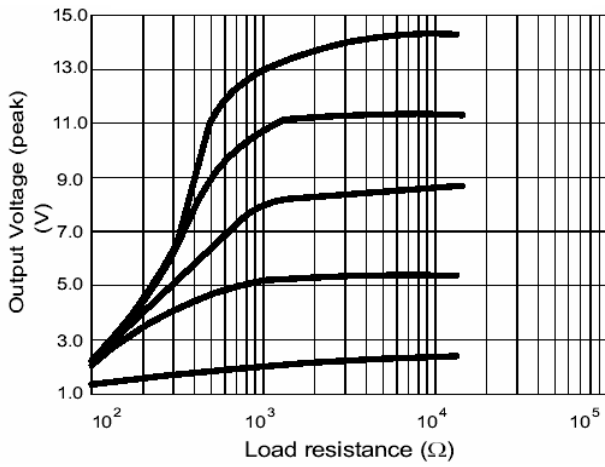

Fig 7. Positive Output Voltage Swing vs. Load Resistance

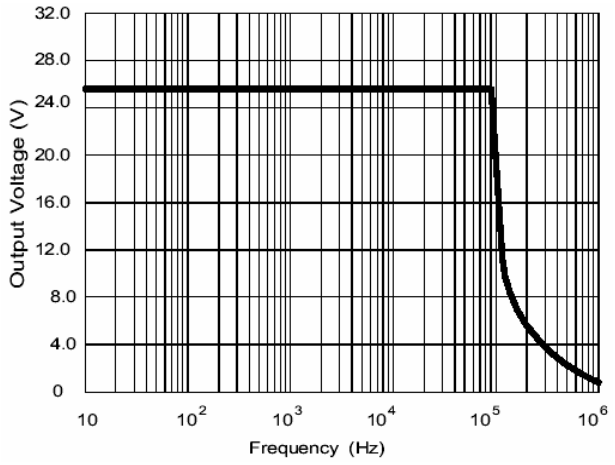

Fig 8. Power Bandwidth (Large Signal)

Important Notice:

- All rights are reserved. Reproduction in whole or in part is prohibited without the prior written approval of GTM.
- GTM reserves the right to make changes to its products without notice.
- GTM semiconductor products are not warranted to be suitable for use in life-support Applications, or systems.
- GTM assumes no liability for any consequence of customer product design, infringement of patents, or application assistance.

Head Office And Factory:

- **Taiwan:** No. 17-1 Tatung Rd. Fu Kou Hsin-Chu Industrial Park, Hsin-Chu, Taiwan, R. O. C.
 TEL : 886-3-597-7061 FAX : 886-3-597-9220, 597-0785
- **China:** (201203) No.255, Jang-Jiang Tsai-Lueng RD. , Pu-Dung-Hsin District, Shang-Hai City, China
 TEL : 86-21-5895-7671 ~ 4 FAX : 86-21-38950165