

S70FL256P

256-Mbit CMOS 3.0 Volt Flash Memory
with 104-MHz SPI (Serial Peripheral Interface) Multi I/O Bus

Data Sheet



Notice to Readers: This document states the current technical specifications regarding the Spansion product(s) described herein. Each product described herein may be designated as Advance Information, Preliminary, or Full Production. See [Notice On Data Sheet Designations](#) for definitions.

Notice On Data Sheet Designations

Spansion Inc. issues data sheets with Advance Information or Preliminary designations to advise readers of product information or intended specifications throughout the product life cycle, including development, qualification, initial production, and full production. In all cases, however, readers are encouraged to verify that they have the latest information before finalizing their design. The following descriptions of Spansion data sheet designations are presented here to highlight their presence and definitions.

Advance Information

The Advance Information designation indicates that Spansion Inc. is developing one or more specific products, but has not committed any design to production. Information presented in a document with this designation is likely to change, and in some cases, development on the product may discontinue. Spansion Inc. therefore places the following conditions upon Advance Information content:

“This document contains information on one or more products under development at Spansion Inc. The information is intended to help you evaluate this product. Do not design in this product without contacting the factory. Spansion Inc. reserves the right to change or discontinue work on this proposed product without notice.”

Preliminary

The Preliminary designation indicates that the product development has progressed such that a commitment to production has taken place. This designation covers several aspects of the product life cycle, including product qualification, initial production, and the subsequent phases in the manufacturing process that occur before full production is achieved. Changes to the technical specifications presented in a Preliminary document should be expected while keeping these aspects of production under consideration. Spansion places the following conditions upon Preliminary content:

“This document states the current technical specifications regarding the Spansion product(s) described herein. The Preliminary status of this document indicates that product qualification has been completed, and that initial production has begun. Due to the phases of the manufacturing process that require maintaining efficiency and quality, this document may be revised by subsequent versions or modifications due to changes in technical specifications.”

Combination

Some data sheets contain a combination of products with different designations (Advance Information, Preliminary, or Full Production). This type of document distinguishes these products and their designations wherever necessary, typically on the first page, the ordering information page, and pages with the DC Characteristics table and the AC Erase and Program table (in the table notes). The disclaimer on the first page refers the reader to the notice on this page.

Full Production (No Designation on Document)

When a product has been in production for a period of time such that no changes or only nominal changes are expected, the Preliminary designation is removed from the data sheet. Nominal changes may include those affecting the number of ordering part numbers available, such as the addition or deletion of a speed option, temperature range, package type, or V_{IO} range. Changes may also include those needed to clarify a description or to correct a typographical error or incorrect specification. Spansion Inc. applies the following conditions to documents in this category:

“This document states the current technical specifications regarding the Spansion product(s) described herein. Spansion Inc. deems the products to have been in sufficient production volume such that subsequent versions of this document are not expected to change. However, typographical or specification corrections, or modifications to the valid combinations offered may occur.”

Questions regarding these document designations may be directed to your local sales office.

S70FL256P

256-Mbit CMOS 3.0 Volt Flash Memory
with 104-MHz SPI (Serial Peripheral Interface) Multi I/O Bus



Data Sheet

Distinctive Characteristics

Architectural Advantages

- **Single power supply operation**
 - Full voltage range: 2.7 to 3.6V read and write operations
- **Memory architecture**
 - Uniform 64 kB sectors
 - Top or bottom parameter block (Two 64-kB sectors broken down into sixteen 4-kB sub-sectors each) for each Flash die
 - Uniform 256 kB sectors (no 4-kB sub-sectors)
 - 256-byte page size
- **Program**
 - Page Program (up to 256 bytes) in 1.5 ms (typical)
 - Program operations are on a page by page basis
 - Accelerated programming mode via 9V W#/ACC pin
 - Quad Page Programming
- **Erase**
 - Bulk erase function for each Flash die
 - Sector erase (SE) command (D8h) for 64 kB and 256 kB sectors
 - Sub-sector erase (P4E) command (20h) for 4 kB sectors (for uniform 64-kB sector device only)
 - Sub-sector erase (P8E) command (40h) for 8 kB sectors (for uniform 64-kB sector device only)
- **Cycling endurance**
 - 100,000 cycles per sector typical
- **Data retention**
 - 20 years typical
- **Device ID**
 - JEDEC standard two-byte electronic signature
 - RES command one-byte electronic signature for backward compatibility

- **One time programmable (OTP) area on each Flash die for permanent, secure identification; can be programmed and locked at the factory or by the customer**
- **CFI (Common Flash Interface) compliant: allows host system to identify and accommodate multiple flash devices**
- **Process technology**
 - Manufactured on 0.09 µm MirrorBit® process technology
- **Package option**
 - Industry Standard Pinouts
 - 16-pin SO package (300 mils)
 - 24-ball BGA (6 x 8 mm) package, 5 x 5 pin configuration

Performance Characteristics

- **Speed**
 - Normal READ (Serial): 40 MHz clock rate
 - FAST_READ (Serial): 104 MHz clock rate (maximum)
 - DUAL I/O FAST_READ: 80 MHz clock rate or 20 MB/s effective data rate
 - QUAD I/O FAST_READ: 80 MHz clock rate or 40 MB/s effective data rate
- **Power saving standby mode**
 - Standby Mode 160 µA (typical)
 - Deep Power-Down Mode 6 µA (typical)

Memory Protection Features

- **Memory protection**
 - W#/ACC pin works in conjunction with Status Register Bits to protect specified memory areas
 - Status Register Block Protection bits (BP2, BP1, BP0) in status

General Description

This document contains information for the S70FL256P device, which is a dual die stack of two S25FL129P die. For detailed specifications, please refer to the discrete die data sheet:

Document	Publication Identification Number (PID)
S25FL129P Data Sheet	S25FL129P_00

Table of Contents

Distinctive Characteristics	3
General Description	3
1. Block Diagram	7
2. Connection Diagrams	8
3. Input/Output Descriptions	9
4. Logic Symbol	9
5. Ordering Information	10
5.1 Valid Combinations	10
6. Device Operations	11
6.1 Programming	11
6.2 Simultaneous Die Operation	11
6.3 Sequential Reads	11
6.4 Sector/Bulk Erase	11
6.5 Status Register	11
6.6 Configuration Register	11
6.7 Block Protection	11
7. Read Identification (RDID)	11
8. DC Characteristics	12
9. Test Conditions	13
10. AC Characteristics	14
10.1 Capacitance	15
11. Physical Dimensions	16
11.1 SL3 016 — 16-pin Wide Plastic Small Outline Package (300-mil Body Width)	16
11.2 ZSA024 — 24-ball Ball Grid Array (6 x 8 mm) package	17
12. Revision History	18

Figures

Figure 2.1	16-pin Plastic Small Outline Package (SO)	8
Figure 2.2	6 x 8 mm 24-ball BGA Package, 5 x 5 Pin Configuration	8
Figure 9.1	AC Measurements I/O Waveform	13
Figure 10.1	AC Characteristics	14

Tables

Table 5.1	S70FL256P Valid Combinations Table	10
Table 7.1	Product Group CFI Device Geometry Definition	11
Table 8.1	DC Characteristics (CMOS Compatible)	12
Table 9.1	Test Specifications	13

1. Block Diagram

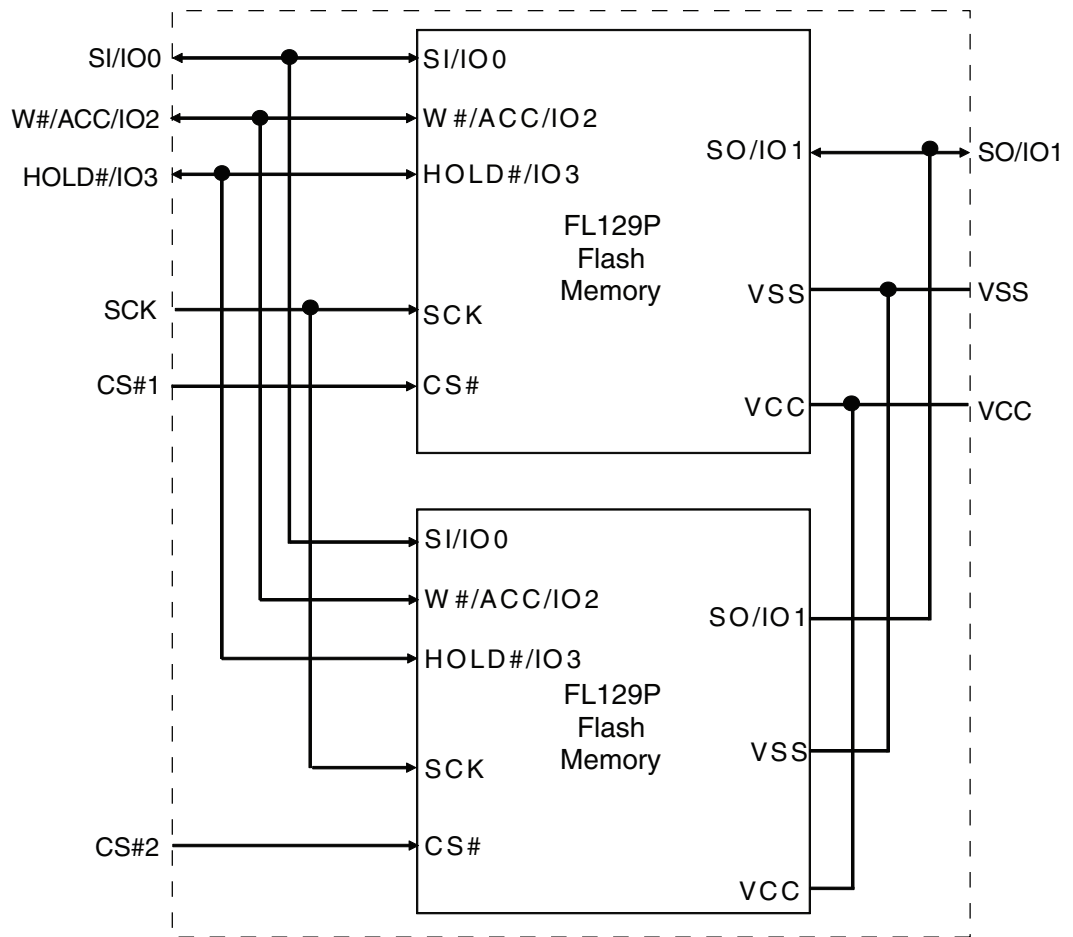

2. Connection Diagrams

Figure 2.1 16-pin Plastic Small Outline Package (SO)

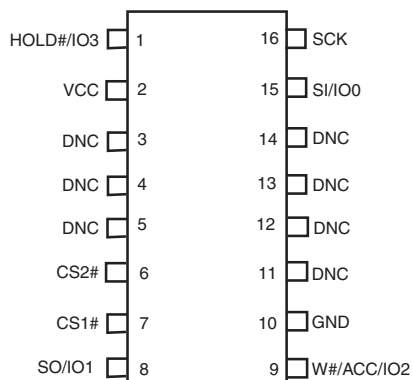

Note:
DNC = Do Not Connect (Reserved for future use)

Figure 2.2 6 x 8 mm 24-ball BGA Package, 5 x 5 Pin Configuration

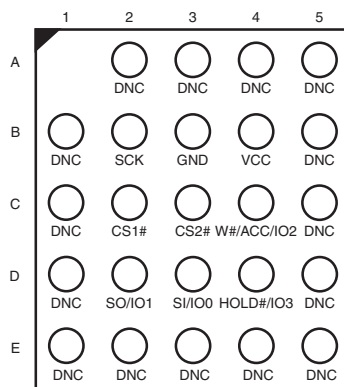

3. Input/Output Descriptions

Signal	I/O	Description
SO/IO1	I/O	Serial Data Output: Transfers data serially out of the device on the falling edge of SCK. Functions as an I/O pin in Dual and Quad I/O, and Quad Page Program modes.
SI/IO0	I/O	Serial Data Input: Transfers data serially into the device. Device latches commands, addresses, and program data on SI on the rising edge of SCK. Functions as an I/O pin in Dual and Quad I/O mode.
SCK	Input	Serial Clock: Provides serial interface timing. Latches commands, addresses, and data on SI on rising edge of SCK. Triggers output on SO after the falling edge of SCK.
CS1# CS2#	Input	Chip Selects: Places one of the Flash die in active power mode when driven low. Deselects Flash die and places SO at high impedance when high. After power-up, device requires a falling edge on CS1# and CS2# before any command is written. Device is in standby mode when a program, erase, or Write Status Register operation is not in progress.
HOLD#/IO3	I/O	Hold: Pauses any serial communication with the device without deselecting it. When driven low, SO is at high impedance, and all input at SI and SCK are ignored. Requires that CS1# or CS2# also be driven low. Functions as an I/O pin in Quad I/O mode.
W#/ACC/IO2	I/O	Write Protect: Protects the memory area specified by Status Register bits BP2:BP0. When driven low, prevents any program or erase command from altering the data in the protected memory area. Functions as an I/O pin in Quad I/O mode.
V _{CC}	Input	Supply Voltage
GND	Input	Ground

4. Logic Symbol

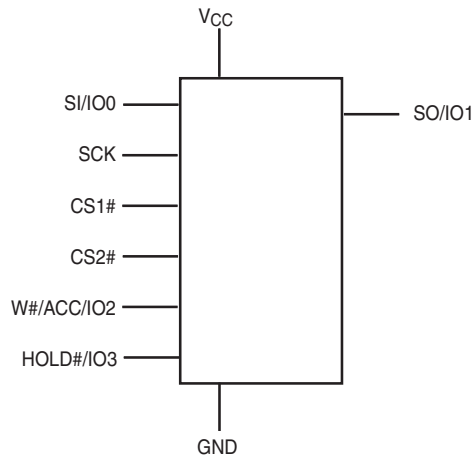

5. Ordering Information

The ordering part number is formed by a valid combination of the following:

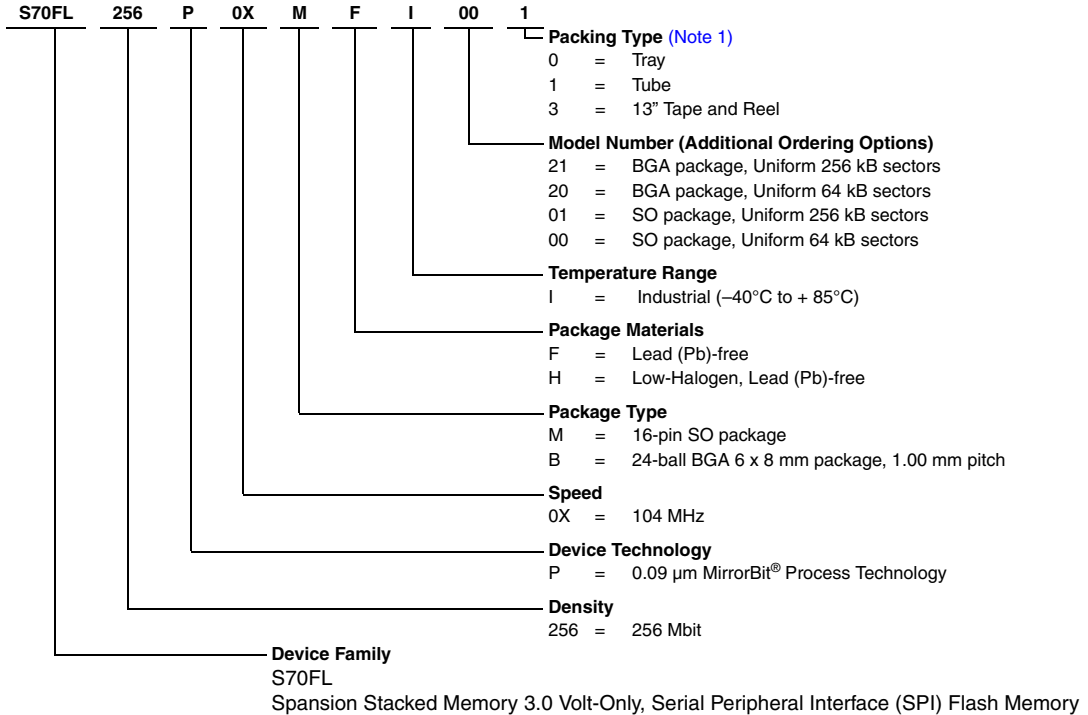

5.1 Valid Combinations

Table 5.1 lists the valid combinations configurations planned to be supported in volume for this device.

Table 5.1 S70FL256P Valid Combinations Table

S70FL256P Valid Combinations					Package Marking
Base Ordering Part Number	Speed Option	Package and Temperature	Model Number	Packing Type	
S70FL256P	0X	MFI	00	0, 1, 3	70FL256P0XMF100
			01		70FL256P0XMF101
		BHI	20	0, 3	70FL256P0XBHI20
			21		70FL256P0XBHI21

Note:

1. Package Marking omits the leading "S70" and speed, package and model number.

6. Device Operations

6.1 Programming

Each Flash die must be programmed independently due to the nature of the dual die stack.

6.2 Simultaneous Die Operation

The user may only access one Flash die of the dual die stack at a time via its respective Chip Select.

6.3 Sequential Reads

Sequential reads are not supported across the end of the first Flash die to the beginning of the second. If the user desires to sequentially read across the two die, data must be read out of the first die via CS1# and then read out of the second die via CS2#.

6.4 Sector/Bulk Erase

A sector erase command must be issued for sectors in each Flash die separately. Full device Bulk Erase via a single command is not supported due to the nature of the dual die stack. A Bulk Erase command must be issued for each die.

6.5 Status Register

Each Flash die of the dual die stack is managed by its own Status Register. Reads and updates to the Status Registers must be managed separately. It is recommended that Status Register control bit settings of each die are kept identical to maintain consistency when switching between die.

6.6 Configuration Register

Each Flash die of the dual die stack is managed by its own Configuration Register. Updates to the Configuration Register control bits must be managed separately. It is recommended that Configuration Register control bit settings of each die are kept identical to maintain consistency when switching between die.

6.7 Block Protection

Each Flash die of the dual die stack will maintain its own Block Protection. Updates to the TBPROT and BPNV bits of each die must be managed separately. By default, each die is configured to be protected starting at the top (highest address) of each array, but no address range is protected. It is recommended that the Block Protection settings of each die are kept identical to maintain consistency when switching between die.

7. Read Identification (RDID)

The Read Identification (RDID) command outputs the one-byte manufacturer identification, followed by the two-byte device identification and the bytes for the Common Flash Interface (CFI) tables. Each die of the FL256P dual die stack will have identical identification data as the FL129P die, with the exception of the CFI data at byte 27h, as shown in [Table 7.1](#).

Table 7.1 Product Group CFI Device Geometry Definition

Byte	Data	Description
27h	19h	Device Size = 2 ^N byte

8. DC Characteristics

This section summarizes the DC Characteristics of the device. Designers should check that the operating conditions in their circuit match the measurement conditions specified in the Test Specifications in [Table 9.1 on page 13](#), when relying on the quoted parameters.

Table 8.1 DC Characteristics (CMOS Compatible)

Symbol	Parameter	Test Conditions	Limits			Unit
			Min.	Typ. (1)	Max.	
V _{CC}	Supply Voltage		2.7		3.6	V
V _{HH}	ACC Program Acceleration Voltage	V _{CC} = 2.7V to 3.6V	8.5		9.5	V
V _{IL}	Input Low Voltage		-0.3		0.3 x V _{CC}	V
V _{IH}	Input High Voltage		0.7 x V _{CC}		V _{CC} + 0.5	V
V _{OL}	Output Low Voltage	I _{OL} = 1.6 mA, V _{CC} = V _{CC} min.			0.4	V
V _{OH}	Output High Voltage	I _{OH} = -0.1 mA	V _{CC} -0.6			V
I _{LI}	Input Leakage Current	V _{CC} = V _{CC} Max, V _{IN} = V _{CC} or GND			±2	µA
I _{LO}	Output Leakage Current	V _{CC} = V _{CC} Max, V _{IN} = V _{CC} or GND			±2	µA
I _{CC1}	Active Power Supply Current - READ (SO = Open)	At 80 MHz (Dual or Quad)			44	mA
		At 104 MHz (Serial)			32	
		At 40 MHz (Serial)			15	
I _{CC2}	Active Power Supply Current (Page Program)	CS# = V _{CC}			26	mA
I _{CC3}	Active Power Supply Current (WRR)	CS# = V _{CC}			15	mA
I _{CC4}	Active Power Supply Current (SE)	CS# = V _{CC}			26	mA
I _{CC5}	Active Power Supply Current (BE) (2)	CS# = V _{CC}			26	mA
I _{SB1}	Standby Current	CS# = V _{CC} ; SO + V _{IN} = GND or V _{CC}		160	500	µA
I _{PD}	Deep Power-down Current	CS# = V _{CC} ; SO + V _{IN} = GND or V _{CC}		6	20	µA

Notes:

1. Typical values are at T_{AI} = 25°C and V_{CC} = 3V.
2. Bulk Erase is on a die per die basis, not for the whole device.

9. Test Conditions

Figure 9.1 AC Measurements I/O Waveform

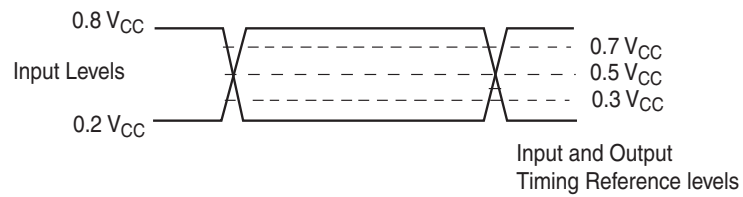

Table 9.1 Test Specifications

Symbol	Parameter	Min	Max	Unit
C_L	Load Capacitance	30		pF
	Input Rise and Fall Times (1)		5	ns
	Input Pulse Voltage	0.2 V_{CC} to 0.8 V_{CC}		V
	Input Timing Reference Voltage	0.3 V_{CC} to 0.7 V_{CC}		V
	Output Timing Reference Voltage	0.5 V_{CC}		V

Note:

1. Input rise and fall times are 0-100%.

10. AC Characteristics

Figure 10.1 AC Characteristics

Symbol (Notes)	Parameter (Notes)	Min. (Notes)	Typ (Notes)	Max (Notes)	Unit
f_R	SCK Clock Frequency for READ command	DC		40	MHz
	SCK Clock Frequency for RDID command	DC		50	MHz
f_C	SCK Clock Frequency for all others: FAST_READ, PP, QPP, P4E, P8E, SE, BE, DP, RES, WREN, WRDI, RDSR, WRR, READ_ID	DC		104 (serial) 80 (dual/quad)	MHz
t_{WH}, t_{CH} (5)	Clock High Time	4.5			ns
t_{WL}, t_{CL} (5)	Clock Low Time	4.5			ns
t_{CRT}, t_{CLCH}	Clock Rise Time (slew rate)	0.1			V/ns
t_{CFT}, t_{CHCL}	Clock Fall Time (slew rate)	0.1			V/ns
t_{CS} (9)	CS# High Time (Read Instructions)	10			ns
	CS# High Time (Program/Erase)	50			ns
t_{CSS}	CS# Active Setup Time (relative to SCK)	3			ns
t_{CSH}	CS# Active Hold Time (relative to SCK)	3			ns
$t_{SU:DAT}$	Data in Setup Time	3			ns
$t_{HD:DAT}$	Data in Hold Time	2			ns
t_V	Clock Low to Output Valid	0		9 (Serial) Δ 10.5 (Dual/Quad) Δ 7.8 (Serial) ∞ 9 (Dual/Quad) ∞	ns
t_{HO}	Output Hold Time	0			ns
t_{DIS}	Output Disable Time			8	ns
t_{HLCH}	HOLD# Active Setup Time (relative to SCK)	3			ns
t_{CHHH}	HOLD# Active Hold Time (relative to SCK)	3			ns
t_{HHCH}	HOLD# Non Active Setup Time (relative to SCK)	3			ns
t_{CHHL}	HOLD# Non Active Hold Time (relative to SCK)	3			ns
t_{HZ}	HOLD# enable to Output Invalid			8	ns
t_{LZ}	HOLD# disable to Output Valid			8	ns
t_{WPS}	W#/ACC Setup Time (4)	20			ns
t_{WPH}	W#/ACC Hold Time (4)	100			ns
t_W	WRR Cycle Time			50	ms
t_{PP}	Page Programming (1)(2)		1.5	3	ms
t_{EP}	Page Programming (ACC = 9V) (1)(2)(3)		1.2	2.4	ms
t_{SE}	Sector Erase Time (64 kB) (1)(2)		0.5	2	sec
	Sector Erase Time (256 kB) (1)(2)		2	8	sec
t_{BE}	Bulk Erase Time (1)(2)(8)		128	256	sec
t_{PE}	Parameter Sector Erase Time (4 kB or 8 kB) (1)(2)		200	800	ms
t_{RES}	Deep Power-down to Standby Mode			30	μ s
t_{DP}	Time to enter Deep Power-down Mode			10	μ s
t_{VHH}	ACC Voltage Rise and Fall time	2.2			μ s
t_{WC}	ACC at V_{HH} and V_{IL} or V_{IH} to first command	5			μ s

Notes:

1. Typical program and erase times assume the following conditions: 25°C, $V_{CC} = 3.0V$; 10,000 cycles; checkerboard data pattern.
2. Under worst-case conditions of 85°C; $V_{CC} = 2.7V$; 100,000 cycles.
3. Acceleration mode (9V ACC) only in Program mode, not Erase.
4. Only applicable as a constraint for WRR instruction when SRWD is set to a '1'.
5. $t_{WH} + t_{WL}$ must be less than or equal to $1/f_C$.
6. Δ Full Vcc range (2.7 – 3.6V) and CL = 30 pF.
7. ∞ Regulated Vcc range (3.0 – 3.6V) and CL = 30 pF.
8. Bulk Erase is on a die per die basis, not for the whole device.
9. When switching between die, a minimum time of t_{CS} must be kept between the rising edge of one chip select and the falling edge of the other for operations and data to be valid.

10.1 Capacitance

Symbol	Parameter	Test Conditions	Min	Max	Unit
C_{IN}	Input Capacitance (applies to CS1#, CS2#, SCK, SI/IO0, SO/IO1, W#/ACC/IO2, HOLD#/IO3)	$V_{OUT} = 0V$		6	pF
C_{OUT}	Output Capacitance (applies to SI/IO0, SO/IO1, W#/ACC/IO2, HOLD#/IO3)	$V_{IN} = 0V$		8	pF

Notes:

1. Sampled, not 100% tested.
2. Test conditions $T_A = 25^{\circ}C$, $f = 1.0$ MHz.
3. For more information on pin capacitance, please consult the IBIS models.

11. Physical Dimensions

11.1 SL3 016 — 16-pin Wide Plastic Small Outline Package (300-mil Body Width)

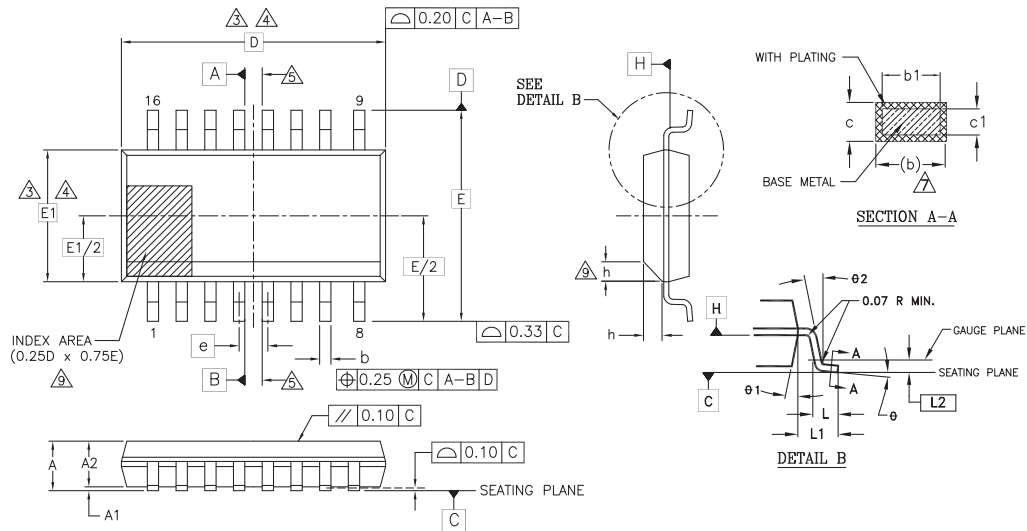

PACKAGE	SL3016 (inches)		SL3016 (mm)	
JEDEC	MS-013(D)AA		MS-013(D)AA	
SYMBOL	MIN	MAX	MIN	MAX
A	0.093	0.104	2.35	2.65
A1	0.004	0.012	0.10	0.30
A2	0.081	0.104	2.05	2.55
b	0.012	0.020	0.31	0.51
b1	0.011	0.019	0.27	0.48
c	0.008	0.013	0.20	0.33
c1	0.008	0.012	0.20	0.30
D	0.406 BSC		10.30 BSC	
E	0.406 BSC		10.30 BSC	
E1	0.295 BSC		7.50 BSC	
e	.050 BSC		1.27 BSC	
L	0.016	0.050	0.40	1.27
L1	.055 REF		1.40 REF	
L2	.010 BSC		0.25 BSC	
N	16		16	
h	0.10	0.30	0.25	0.75
theta	0°	8°	0°	8°
theta1	5°	15°	5°	15°
theta2	0°		0°	

NOTES:

- ALL DIMENSIONS ARE IN BOTH INCHES AND MILLIMETERS.
- DIMENSIONING AND TOLERANCING PER ASME Y14.5M - 1994.
- DIMENSION D DOES NOT INCLUDE MOLD FLASH, PROTRUSIONS OR GATE BURRS. MOLD FLASH, PROTRUSIONS OR GATE BURRS SHALL NOT EXCEED 0.15 mm PER END. DIMENSION E1 DOES NOT INCLUDE INTERLEAD FLASH OR PROTRUSION INTERLEAD FLASH OR PROTRUSION SHALL NOT EXCEED 0.25 mm PER SIDE. D AND E1 DIMENSIONS ARE DETERMINED AT DATUM H.
- THE PACKAGE TOP MAY BE SMALLER THAN THE PACKAGE BOTTOM. DIMENSIONS D AND E1 ARE DETERMINED AT THE OUTMOST EXTREMES OF THE PLASTIC BODY EXCLUSIVE OF MOLD FLASH, TIE BAR BURRS, GATE BURRS AND INTERLEAD FLASH, BUT INCLUDING ANY MISMATCH BETWEEN THE TOP AND BOTTOM OF THE PLASTIC BODY.
- DATUMS A AND B TO BE DETERMINED AT DATUM H.
- "N" IS THE MAXIMUM NUMBER OF TERMINAL POSITIONS FOR THE SPECIFIED PACKAGE LENGTH.
- THE DIMENSIONS APPLY TO THE FLAT SECTION OF THE LEAD BETWEEN 0.10 TO 0.25 mm FROM THE LEAD TIP.
- DIMENSION "b" DOES NOT INCLUDE DAMBAR PROTRUSION. ALLOWABLE DAMBAR PROTRUSION SHALL BE 0.10 mm TOTAL IN EXCESS OF THE "b" DIMENSION AT MAXIMUM MATERIAL CONDITION. THE DAMBAR CANNOT BE LOCATED ON THE LOWER RADIUS OF THE LEAD FOOT.
- THIS CHAMFER FEATURE IS OPTIONAL. IF IT IS NOT PRESENT, THEN A PIN 1 IDENTIFIER MUST BE LOCATED WITHIN THE INDEX AREA INDICATED.
- LEAD COPLANARITY SHALL BE WITHIN 0.10 mm AS MEASURED FROM THE SEATING PLANE.

3644.1, 16-038.03 Rev C | 02.03.10 (JK)

11.2 ZSA024 — 24-ball Ball Grid Array (6 x 8 mm) package

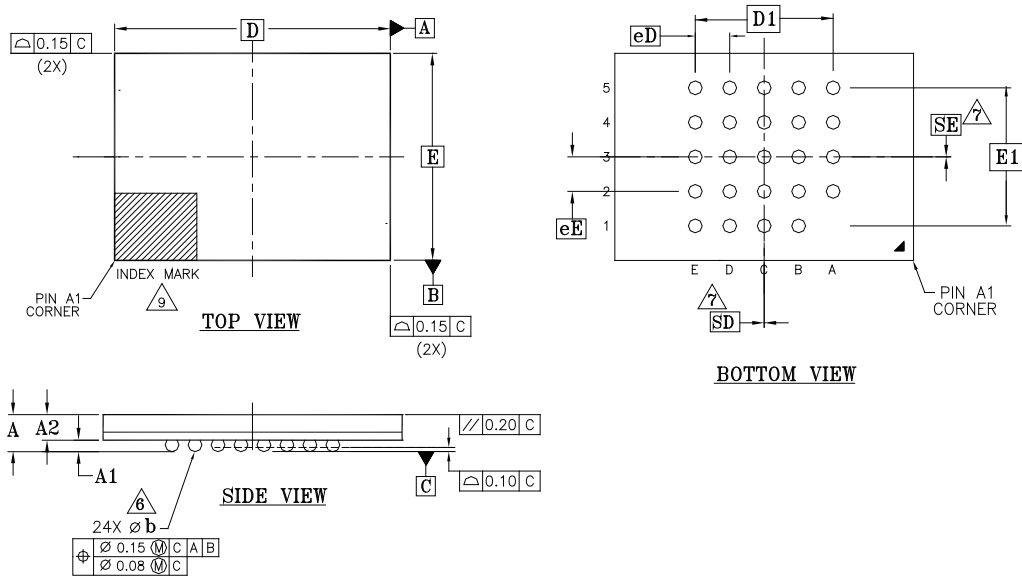

PACKAGE	ZSA024			
JEDEC	N/A			
D x E	8.00 mm x 6.00 mm PACKAGE			
SYMBOL	MIN	NOM	MAX	NOTE
A	---	---	1.20	PROFILE
A1	0.20	---	---	BALL HEIGHT
A2	0.70	---	0.90	BODY THICKNESS
D	8.00 BSC.			BODY SIZE
E	6.00 BSC.			BODY SIZE
D1	4.00 BSC.			MATRIX FOOTPRINT
E1	4.00 BSC.			MATRIX FOOTPRINT
MD	5			MATRIX SIZE D DIRECTION
ME	5			MATRIX SIZE E DIRECTION
n	24			BALL COUNT
ϕb	0.35	0.40	0.45	BALL DIAMETER
eE	1.00 BSC.			BALL PITCH
eD	1.00 BSC.			BALL PITCH
SD/SE	0.00			SOLDER BALL PLACEMENT
	A1			DEPOPULATED SOLDER BALLS

NOTES:

- DIMENSIONING AND TOLERANCING METHODS PER ASME Y14.5M-1994.
- ALL DIMENSIONS ARE IN MILLIMETERS.
- BALL POSITION DESIGNATION PER JE95, SECTION 4.3, SPP-010.
- [e] REPRESENTS THE SOLDER BALL GRID PITCH.
- SYMBOL "MD" IS THE BALL MATRIX SIZE IN THE "D" DIRECTION.
SYMBOL "ME" IS THE BALL MATRIX SIZE IN THE "E" DIRECTION.
n IS THE NUMBER OF POPULATED SOLDER BALL POSITIONS FOR MATRIX SIZE MD X ME.
- DIMENSION "b" IS MEASURED AT THE MAXIMUM BALL DIAMETER IN A PLANE PARALLEL TO DATUM C.
DATUM C IS THE SEATING PLANE AND IS DEFINED BY THE CROWNS OF THE SOLDER BALLS.
- SD AND SE ARE MEASURED WITH RESPECT TO DATUMS A AND B AND DEFINE THE POSITION OF THE CENTER SOLDER BALL IN THE OUTER ROW.
WHEN THERE IS AN ODD NUMBER OF SOLDER BALLS IN THE OUTER ROW SD OR SE = 0.000.
WHEN THERE IS AN EVEN NUMBER OF SOLDER BALLS IN THE OUTER ROW, SD OR SE = e/2
- "+" INDICATES THE THEORETICAL CENTER OF DEPOPULATED BALLS.
- A1 CORNER TO BE IDENTIFIED BY CHAMFER, LASER OR INK MARK, METALLIZED MARK INDENTATION OR OTHER MEANS.

3645 16-038.86 Rev A 1/02.26.10

12. Revision History

Section	Description
Revision 01 (March 3, 2010)	
	Initial release
Revision 02 (March 17, 2010)	
Valid Combinations	Corrected Package Marking specification from discrete to MCP format
Read Identification (RDID)	Added section to explain CFI change from FL129P
Revision 03 (June 17, 2010)	
General	Changed product description from “256-Mbit CMOS 3.0 Volt Flash Memory with 93-MHz SPI Serial (Serial Peripheral Interface) Multi I/O Bus” to “256-Mbit CMOS 3.0 Volt Flash Memory with 104-MHz SPI Serial (Serial Peripheral Interface) Multi I/O Bus” Changed data sheet status from <i>Advanced Information</i> to <i>Preliminary</i>
Distinctive Characteristics	Changed Normal READ clock rate from 36 to 40 MHz Changed FAST_READ maximum clock rate from 93 to 104 MHz Changed DUAL I/O FAST_READ clock rate from 72 to 80 MHz and effective data rate from 18 to 20 MB/s
Ordering Information	Changed description for Speed characters 0X from 93 to 104 MHz
DC Characteristics	Changed I_{LI} (Input Leakage Current) value from ± 4 to ± 2 μ A (max) Changed I_{LO} (Output Leakage Current) value from ± 4 to ± 2 μ A (max) Changed I_{CC1} (Active Power Supply Current - READ) test condition frequencies from 72/93/36 MHz to 80/104/40 MHz Changed I_{CC1} (Active Power Supply Current - READ) value @ 80 MHz (dual/quad) from 41.8 to 44 mA (max) Changed I_{CC1} (Active Power Supply Current - READ) value @ 104 MHz (serial) from 27.5 to 32 mA (max) Changed I_{CC1} (Active Power Supply Current - READ) value @ 40 MHz (serial) from 13.2 to 15 mA (max) Changed I_{CC2} (Active Power Supply Current - Page Program) value from 28.6 to 26 mA (max) Changed I_{CC3} (Active Power Supply Current - WRR) value from 16.5 to 15 mA (max) Changed I_{CC4} (Active Power Supply Current - SE) value from 28.6 to 26 mA (max) Changed I_{CC5} (Active Power Supply Current - BE) value from 28.6 to 26 mA (max) Added Note 2, clarifying that Bulk Erase is on a die per die basis, not for the whole device
Test Conditions	Added note clarifying that input rise and fall times are 0-100%
AC Characteristics	Changed f_R (SCK Frequency for READ/RDID) values from 36/45 to 40/50 MHz (max) Changed f_C (SCK Frequency for others) values from 93/72 to 104/80 MHz (max) Changed t_V (Clock Low to Output Valid) values from 9.6/11.4/7.8/9.6 to 9/10.5/7.8/9 ns (max) Added t_{BE} (Bulk Erase Time) Added Note 8 clarifying that Bulk Erase is on a die per die basis, not for the whole device Added Note 9 clarifying that a minimum time of t_{CS} must be kept between the rising edge of one chip select and the falling edge of the other when switching between die for proper device functionality.
Capacitance	Merged C_{IN} capacitance values into a single line item Merged Single I/O, Dual I/O, and Quad I/O max capacitance values into a single line item Added C_{IN} / C_{OUT} (Input / Output Capacitance) values of 6/8 pF (max) Added Notes clarifying test conditions
Revision 04 (June 24, 2011)	
Global	Promoted data sheet designation from Preliminary to Full Production

Colophon

The products described in this document are designed, developed and manufactured as contemplated for general use, including without limitation, ordinary industrial use, general office use, personal use, and household use, but are not designed, developed and manufactured as contemplated (1) for any use that includes fatal risks or dangers that, unless extremely high safety is secured, could have a serious effect to the public, and could lead directly to death, personal injury, severe physical damage or other loss (i.e., nuclear reaction control in nuclear facility, aircraft flight control, air traffic control, mass transport control, medical life support system, missile launch control in weapon system), or (2) for any use where chance of failure is intolerable (i.e., submersible repeater and artificial satellite). Please note that Spansion will not be liable to you and/or any third party for any claims or damages arising in connection with above-mentioned uses of the products. Any semiconductor devices have an inherent chance of failure. You must protect against injury, damage or loss from such failures by incorporating safety design measures into your facility and equipment such as redundancy, fire protection, and prevention of over-current levels and other abnormal operating conditions. If any products described in this document represent goods or technologies subject to certain restrictions on export under the Foreign Exchange and Foreign Trade Law of Japan, the US Export Administration Regulations or the applicable laws of any other country, the prior authorization by the respective government entity will be required for export of those products.

Trademarks and Notice

The contents of this document are subject to change without notice. This document may contain information on a Spansion product under development by Spansion. Spansion reserves the right to change or discontinue work on any product without notice. The information in this document is provided as is without warranty or guarantee of any kind as to its accuracy, completeness, operability, fitness for particular purpose, merchantability, non-infringement of third-party rights, or any other warranty, express, implied, or statutory. Spansion assumes no liability for any damages of any kind arising out of the use of the information in this document.

Copyright © 2010-2011 Spansion Inc. All rights reserved. Spansion®, the Spansion logo, MirrorBit®, MirrorBit® Eclipse™, ORNAND™, EcoRAM™ and combinations thereof, are trademarks and registered trademarks of Spansion LLC in the United States and other countries. Other names used are for informational purposes only and may be trademarks of their respective owners.